

PRODUCT NUMBER  
SEE TABLE

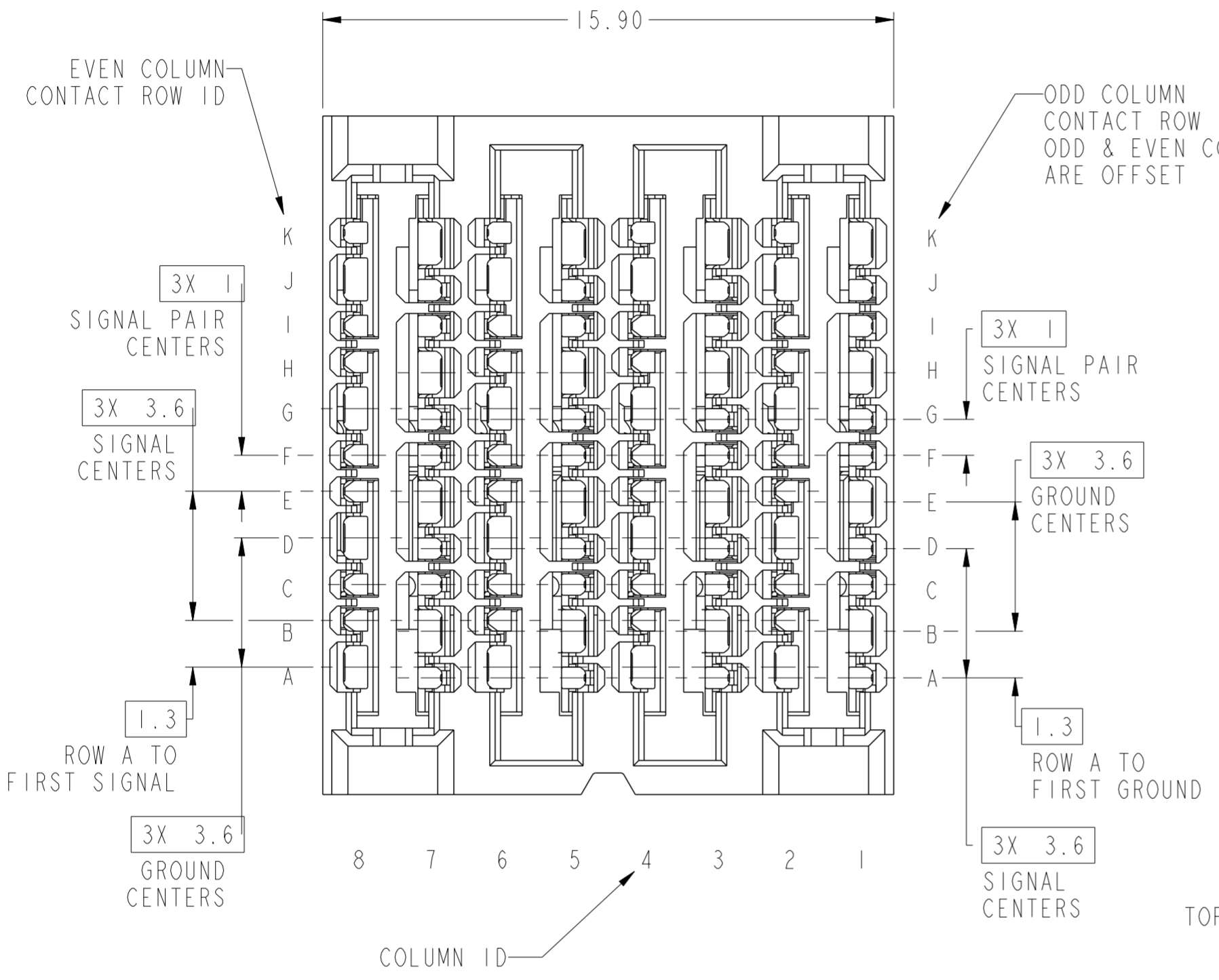

**10124308-101LF  
STANDARD MATE RECEPTACLE**

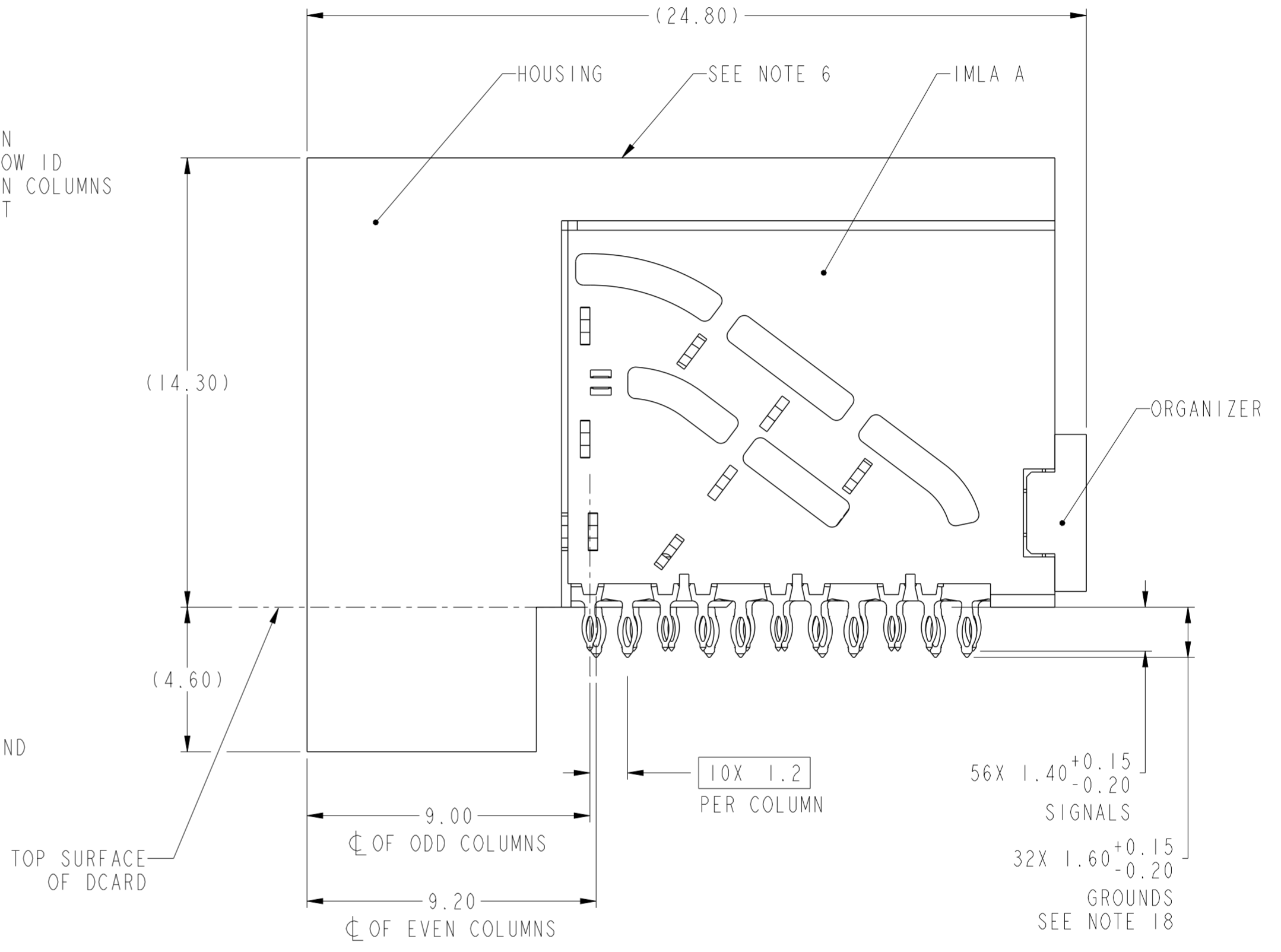

spec ref	SEE NOTES	dr	Heaven Cen	2013/05/14	projection	MM	size	A2	scale	7:1	
tolerance std	TOLERANCES UNLESS OTHERWISE SPECIFIED	eng	Terry Luo	2016/04/12			ecn no	-	rel level	Preliminary	
ASME Y14.5M		chr	-	product family							ExaMAX
surface	linear	0.X	±.3	Amphenol FCI							title
		0.XX	±.10		ASS'Y, 3 PR, 88 POS, 8 IMLA	cat. no.	Product - Customer Drw	sheet 1 of 10			
		0.XXX	±.050								
		angular	0°	±°							

Amphenol FCI

© 2016 AFCI

1 2 3 4 5 6 7 8

A  
B  
C  
D  
E  
F

A  
B  
C  
D  
E  
F

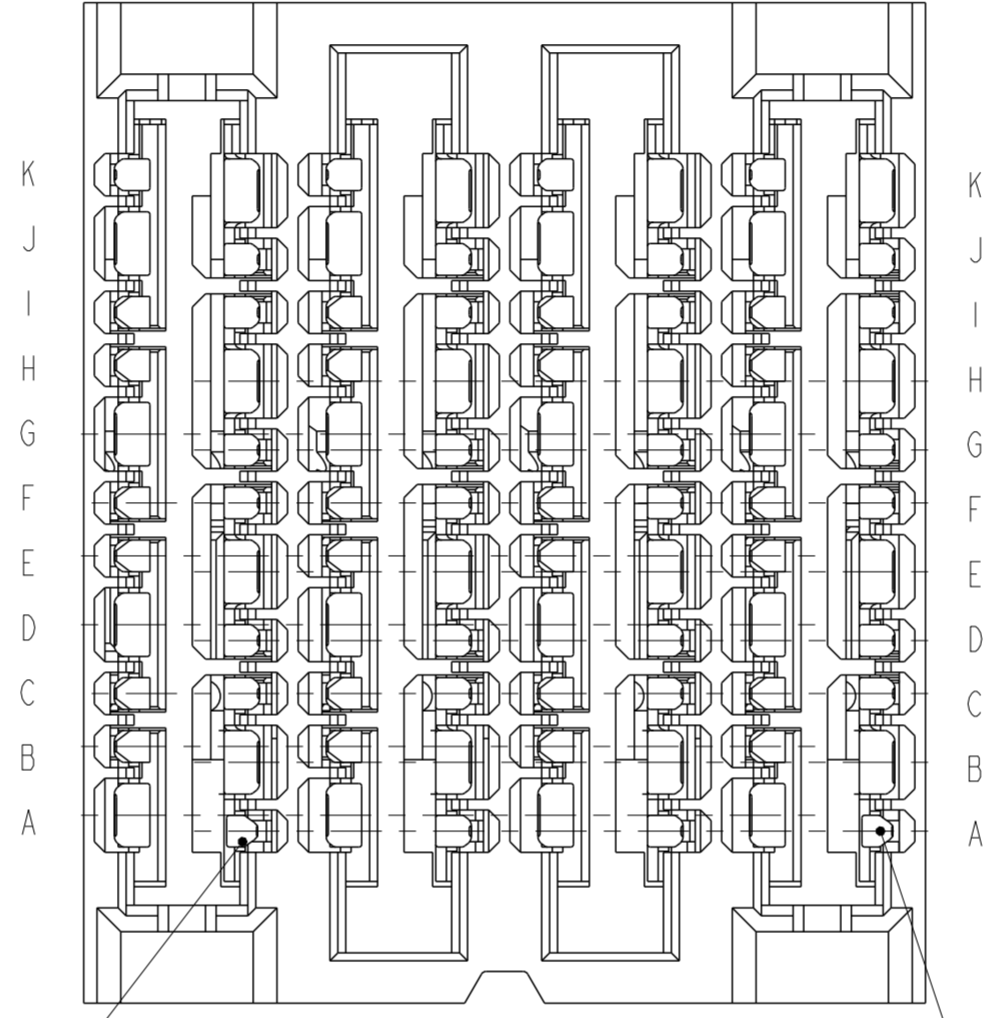

ADVANCED MATE POSITION A7 SEE NOTE 13

ADVANCED MATE POSITION A1 SEE NOTE 13

**10124308-201LF**  
**ADVANCED MATE RECEPTACLE**  
**ADVANCED MATE POSITIONS ARE POSITIONS A1 AND A7 ONLY**  
**FOR ALL DIMENSIONS SEE SHEET 1**

Amphenol  
FCi

© 2016 AFci

spec ref	SEE NOTES	dr	Heaven Cen	2013/05/14	projection	MM	size	A2	scale	7:1
tolerance std	ASME Y14.5M	eng	Terry Luo	2016/04/12			ecn no	-	rel level	Preliminary
surface	-	chr	-	appr			-	product family		ExaMAX
		linear	0.X	±.3		<b>title</b> ExaMAX R.A. RECEPTACLE ASS'Y, 3 PR, 88 POS, 8 IMLA	<b>dwg no</b> 10124308	<b>rev</b> 12	<b>cat. no.</b> Product - Customer Drw	sheet 2 of 10
			0.XX	±.10						
		angular	0°	±°						

3 4 5 6 7 8

SHORT DETECT  
POSITION K2  
SEE NOTE 14

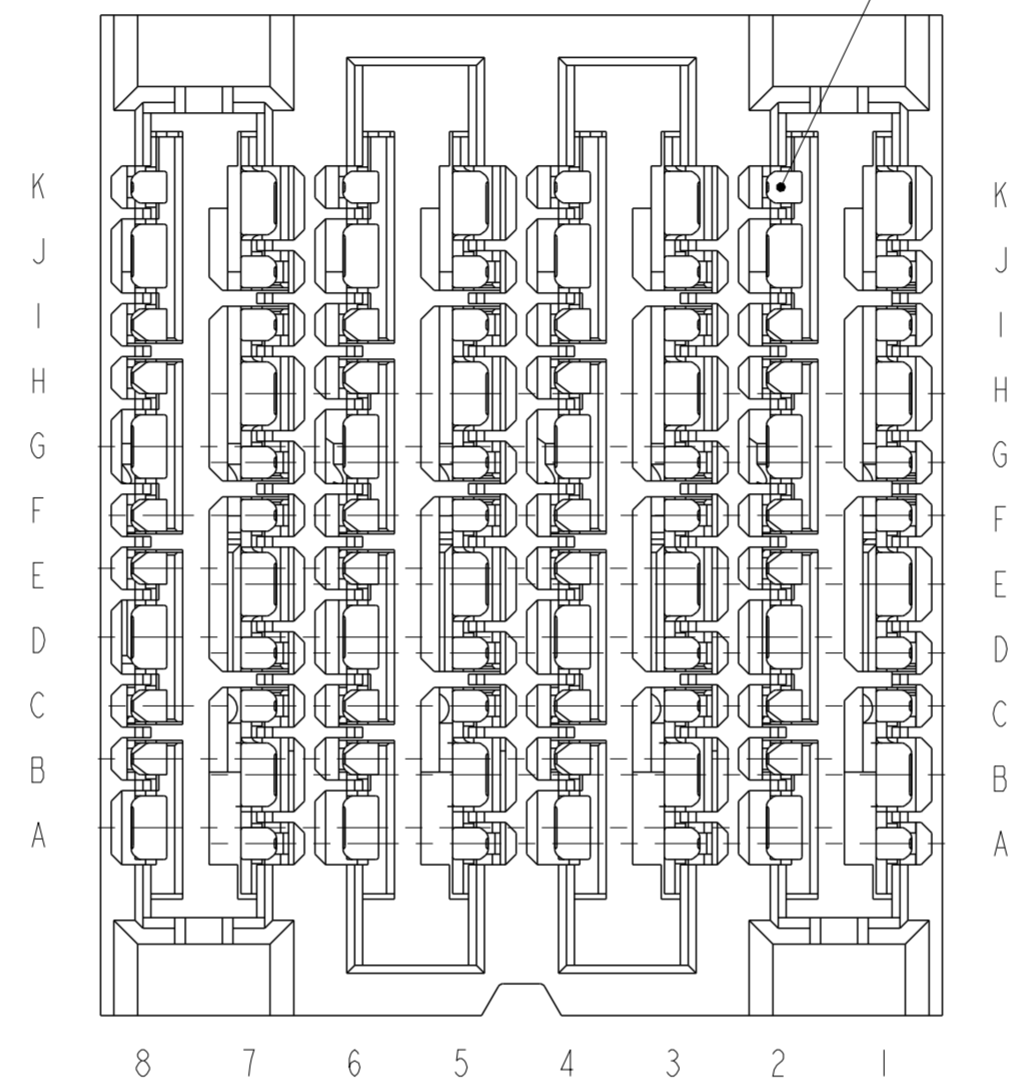

**10124308-301LF**  
**SHORT DETECT RECEPTACLE**  
**SHORT DETECT POSITION IS K2**  
**FOR ALL DIMENSIONS SEE SHEET 1**

**Amphenol  
FCi**

© 2016 AFci

spec ref	SEE NOTES	dr	Heaven Cen	2013/05/14	projection	MM	size	A2	scale	7:1							
tolerance std	TOLERANCES UNLESS OTHERWISE SPECIFIED	eng	Terry Luo	2016/04/12			ecn no	-	rel level <b>Preliminary</b>								
ASME Y14.5M		chr	-	cat. no.			-										
surface	<table border="1"> <tr> <td rowspan="3">linear</td> <td>0.X</td> <td>±.3</td> </tr> <tr> <td>0.XX</td> <td>±.10</td> </tr> <tr> <td>0.XXX</td> <td>±.050</td> </tr> <tr> <td>angular</td> <td>0°</td> <td>±°</td> </tr> </table>	linear	0.X	±.3	0.XX	±.10	0.XXX	±.050	angular	0°	±°		<b>ExaMAX R.A. RECEPTACLE</b> ASS'Y, 3 PR, 88 POS, 8 IMLA		title ExaMAX	dwg no 10124308	rev 12
linear	0.X		±.3														
	0.XX		±.10														
	0.XXX	±.050															
angular	0°	±°															
Product - Customer Drw						sheet 3 of 10											

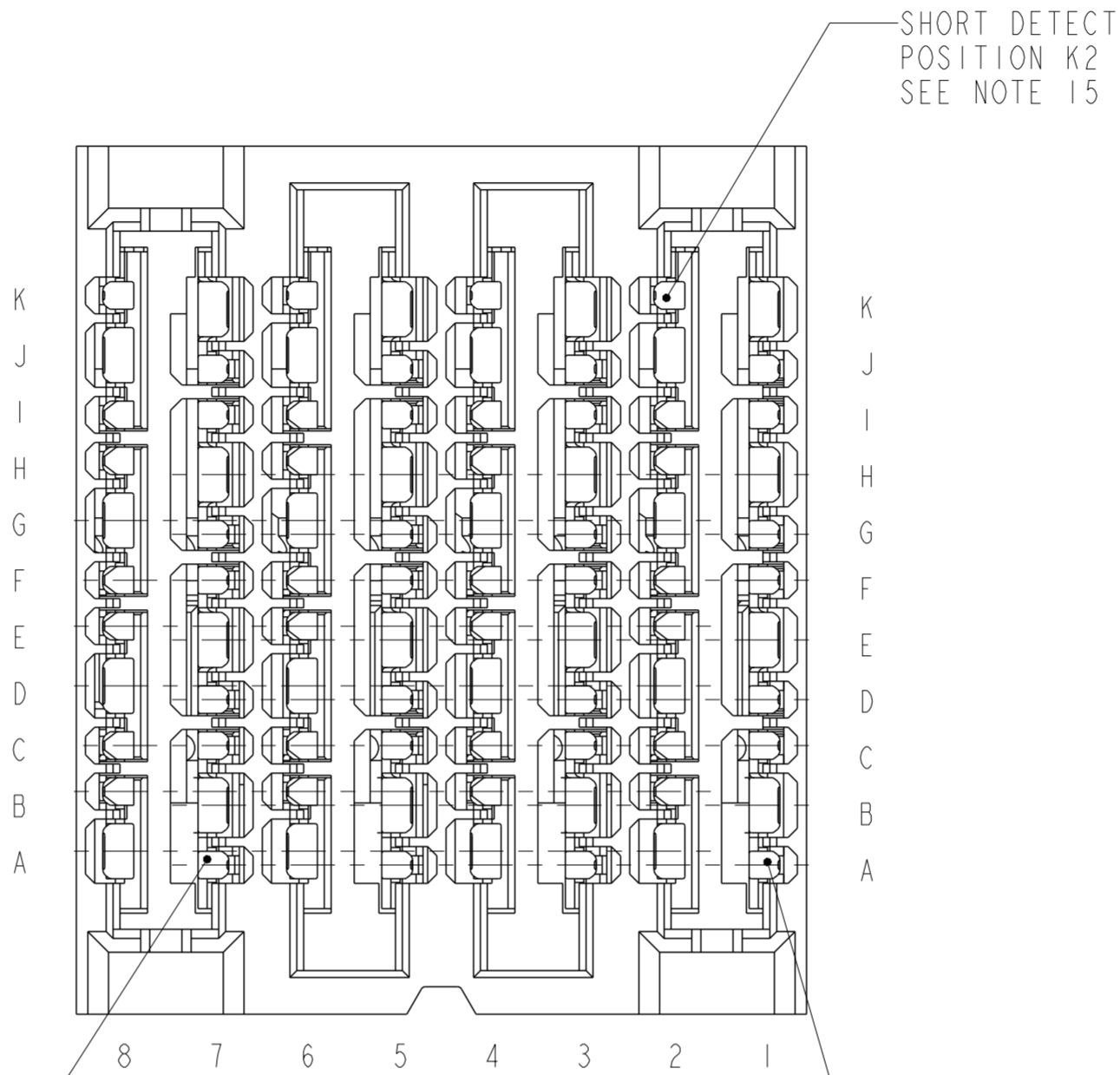

**10124308-401LF**  
**ADVANCED MATE/SHORT DETECT RECEPTACLE**  
**ADVANCED MATE POSITIONS ARE POSITIONS A1 AND A7 ONLY**  
**SHORT DETECT POSITION IS K2**  
**FOR ALL DIMENSIONS SEE SHEET 1**

**Amphenol  
FCi**

© 2016 AFci

spec ref	SEE NOTES	dr	Heaven Cen	2013/05/14	projection	MM	size	A2	scale	7:1					
tolerance std	TOLERANCES UNLESS OTHERWISE SPECIFIED	eng	Terry Luo	2016/04/12			ecn no	-	rel level	Preliminary					
ASME Y14.5M		chr	-	appr			-	product family		ExaMAX					
surface	<table border="1"> <tr> <td rowspan="3">linear</td> <td>0.X</td> <td>±.3</td> </tr> <tr> <td>0.XX</td> <td>±.10</td> </tr> <tr> <td>0.XXX</td> <td>±.050</td> </tr> <tr> <td>angular</td> <td>0°</td> <td>±°</td> </tr> </table>	linear	0.X	±.3	0.XX	±.10	0.XXX	±.050	angular	0°	±°		title ExaMAX R.A. RECEPTACLE ASS'Y, 3 PR, 88 POS, 8 IMLA	cat. no. 10124308	rev 12
linear	0.X		±.3												
	0.XX		±.10												
	0.XXX	±.050													
angular	0°	±°													
Product - Customer Drw						sheet 4 of 10									

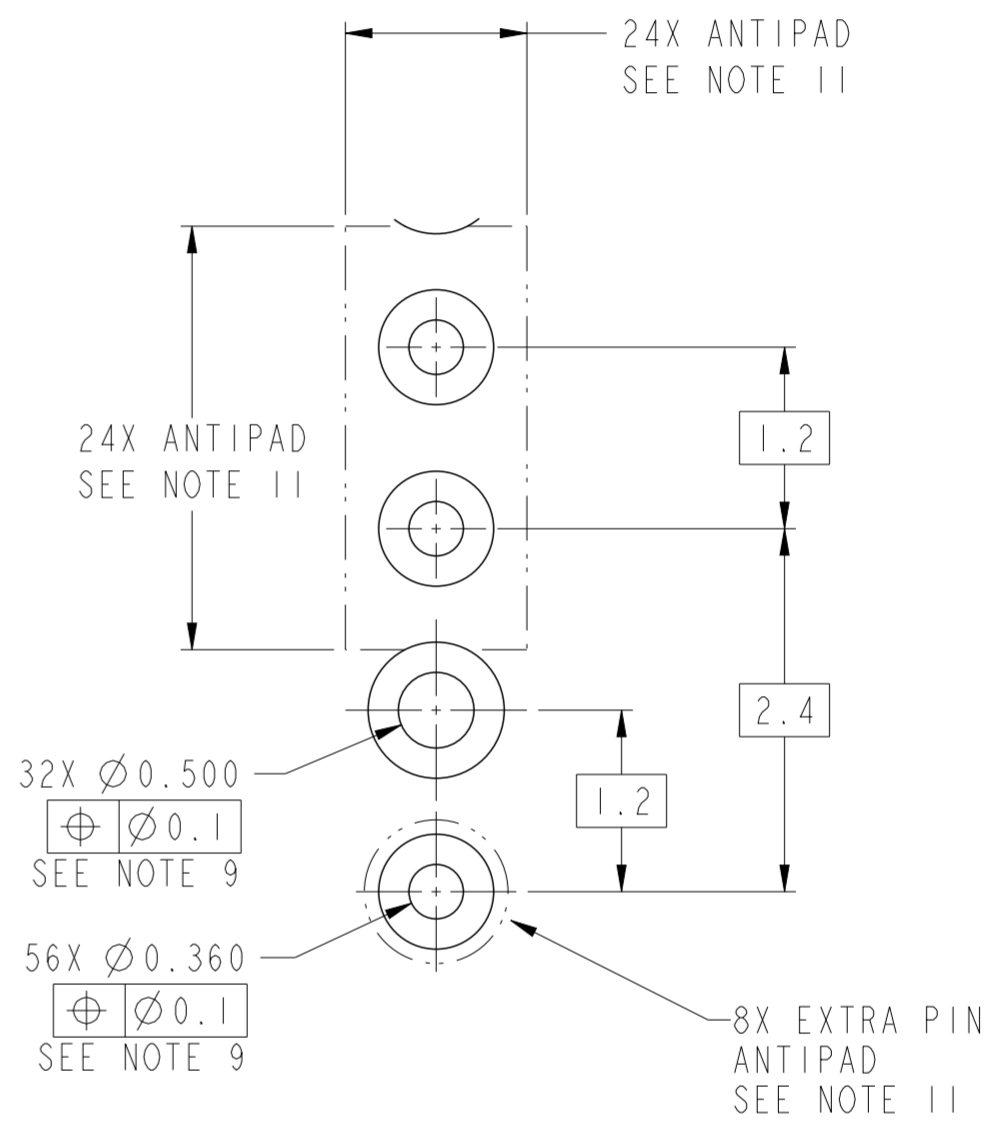
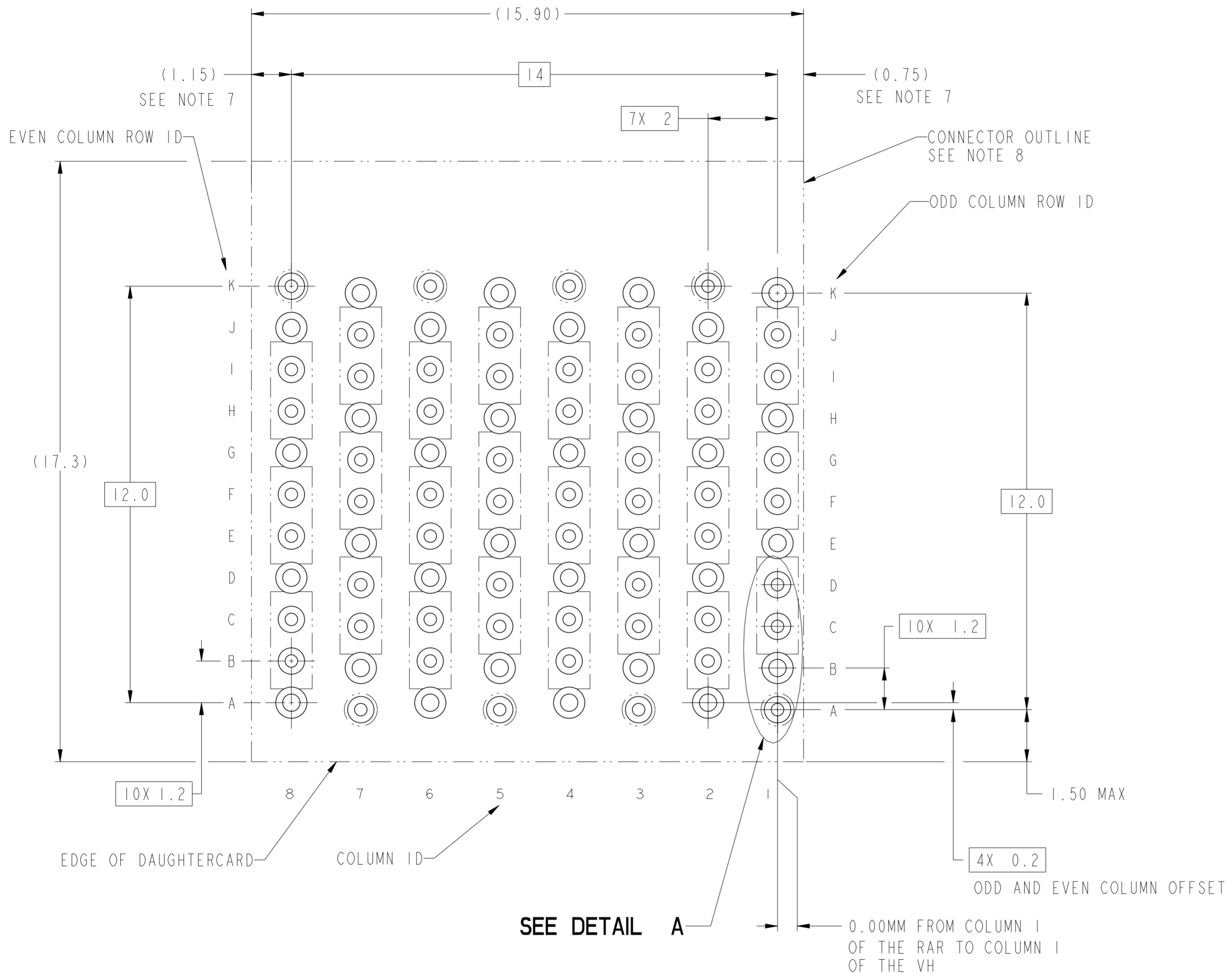

**DETAIL A**  
**SCALE 20:1**

**10124308-Y01 RECOMMENDED PCB LAYOUT**  
**COMPONENT SIDE**  
**NOTES 7, 8, 9, & 11**  
**SCALE 10:1**

spec ref	SEE NOTES	dr	Heaven Cen	2013/05/14	projection	MM	size	A2	scale	7:1
tolerance std	TOLERANCES UNLESS OTHERWISE SPECIFIED	eng	Terry Luo	2016/04/12			ecn no	-	rel level	Preliminary
ASME Y14.5M		chr	-	appr						
surface	linear	0.X	±.3	<b>Amphenol FCI</b>		title ExaMAX R.A. RECEPTACLE ASS'Y, 3 PR, 88 POS, 8 IMLA		dwg no 10124308		rev 12
		0.XX	±.10							
		0.XXX	±.050							
	angular	0°	±°	cat. no.	Product - Customer Drw		sheet 5 of 10			

**Amphenol FCI**

© 2016 APCI

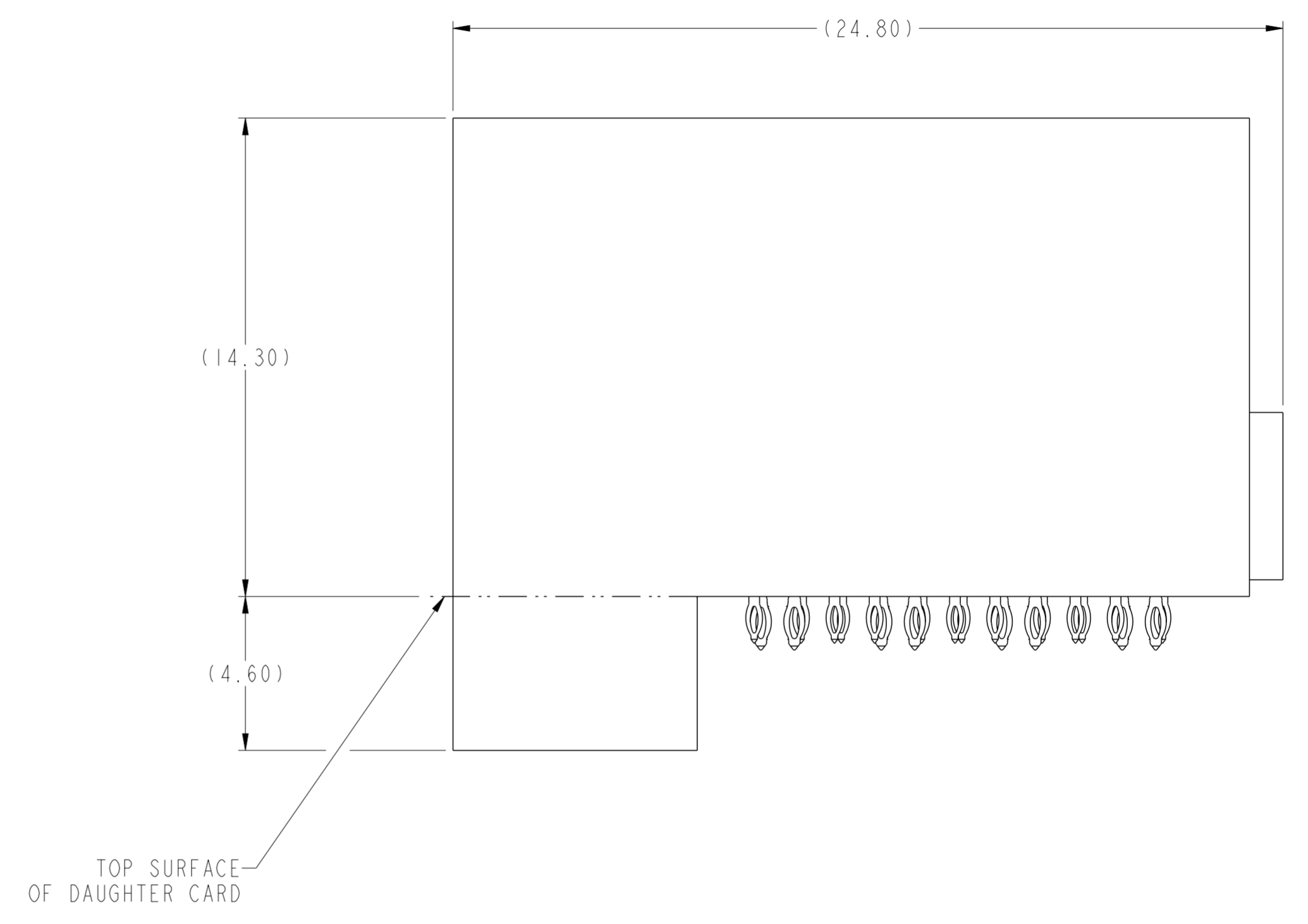
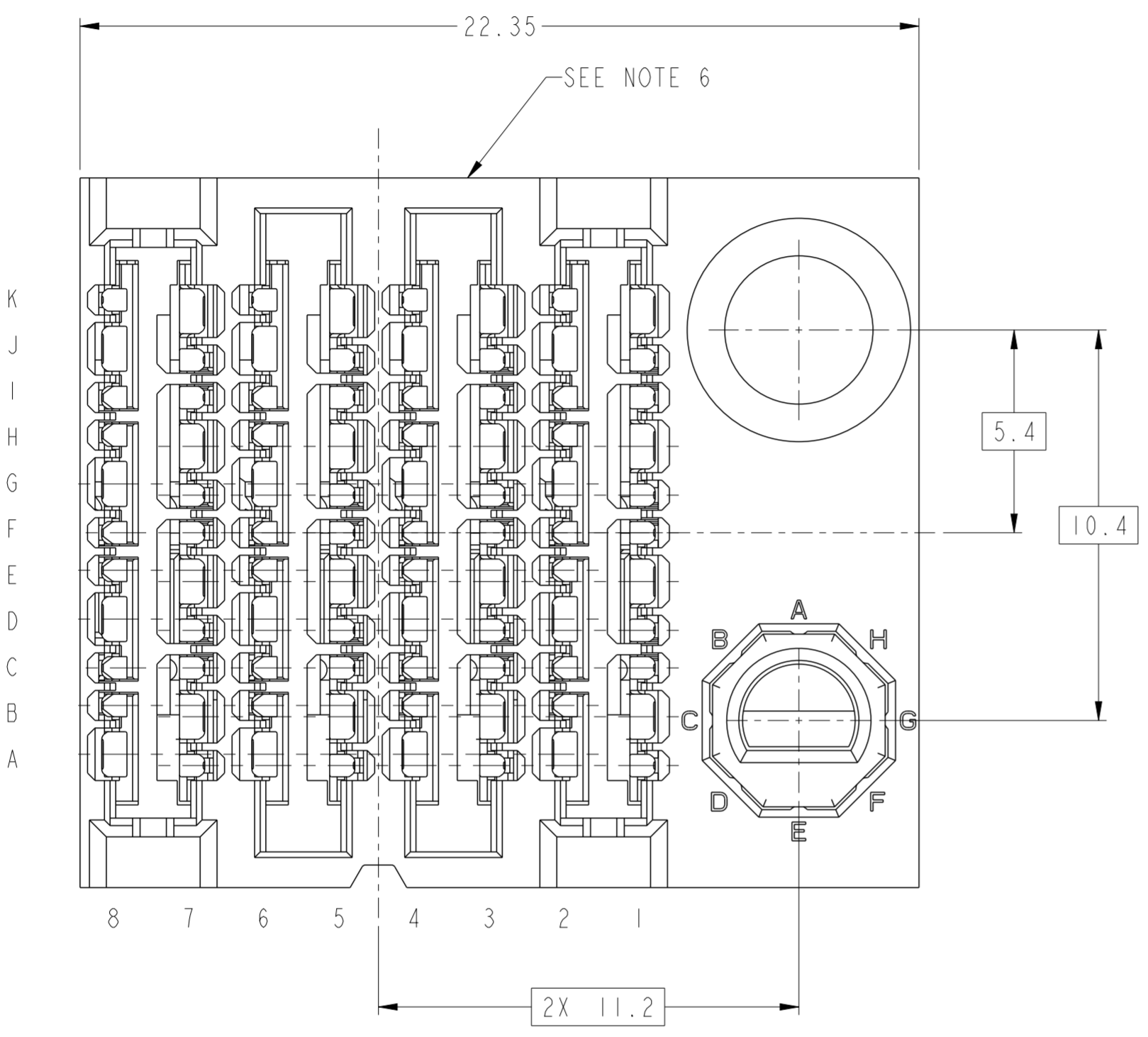

10124308-Y1ALF THRU -Y1JLF  
 RIGHT GUIDANCE (SEE NOTE 17)  
 FOR ALL OTHER DIMENSIONS SEE SHEET 1

Amphenol  
 FCI

© 2016 AFCI

spec ref	SEE NOTES	dr	Heaven Cen	2013/05/14	projection	MM	size	A2	scale	7:1								
tolerance std	TOLERANCES UNLESS OTHERWISE SPECIFIED	eng	Terry Luo	2016/04/12			ecn no	-	rel level <b>Preliminary</b>									
ASME Y14.5M		chr	-	cat. no.			-											
surface	<table border="1"> <tr> <td>linear</td> <td>0.X</td> <td>±.3</td> </tr> <tr> <td></td> <td>0.XX</td> <td>±.10</td> </tr> <tr> <td></td> <td>0.XXX</td> <td>±.050</td> </tr> <tr> <td>angular</td> <td>0°</td> <td>±°</td> </tr> </table>	linear	0.X	±.3		0.XX	±.10		0.XXX	±.050	angular	0°	±°	Amphenol <b>FCI</b>	<b>title</b> ExaMAX R.A. RECEPTACLE ASS'Y, 3 PR, 88 POS, 8 IMLA		<b>dwg no</b> 10124308	<b>rev</b> 12
linear	0.X	±.3																
	0.XX	±.10																
	0.XXX	±.050																
angular	0°	±°																
Product - Customer Drw						sheet 6 of 10												

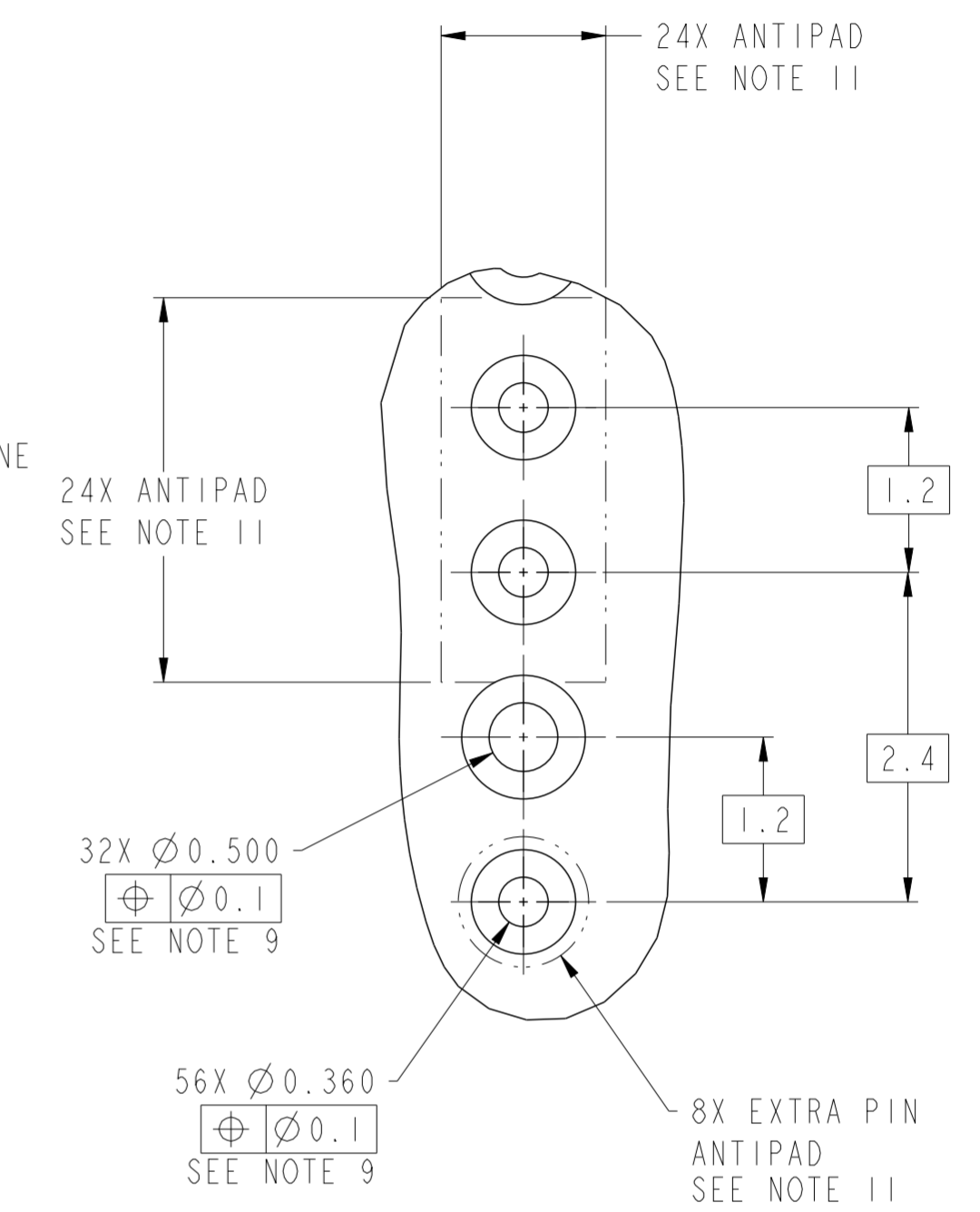
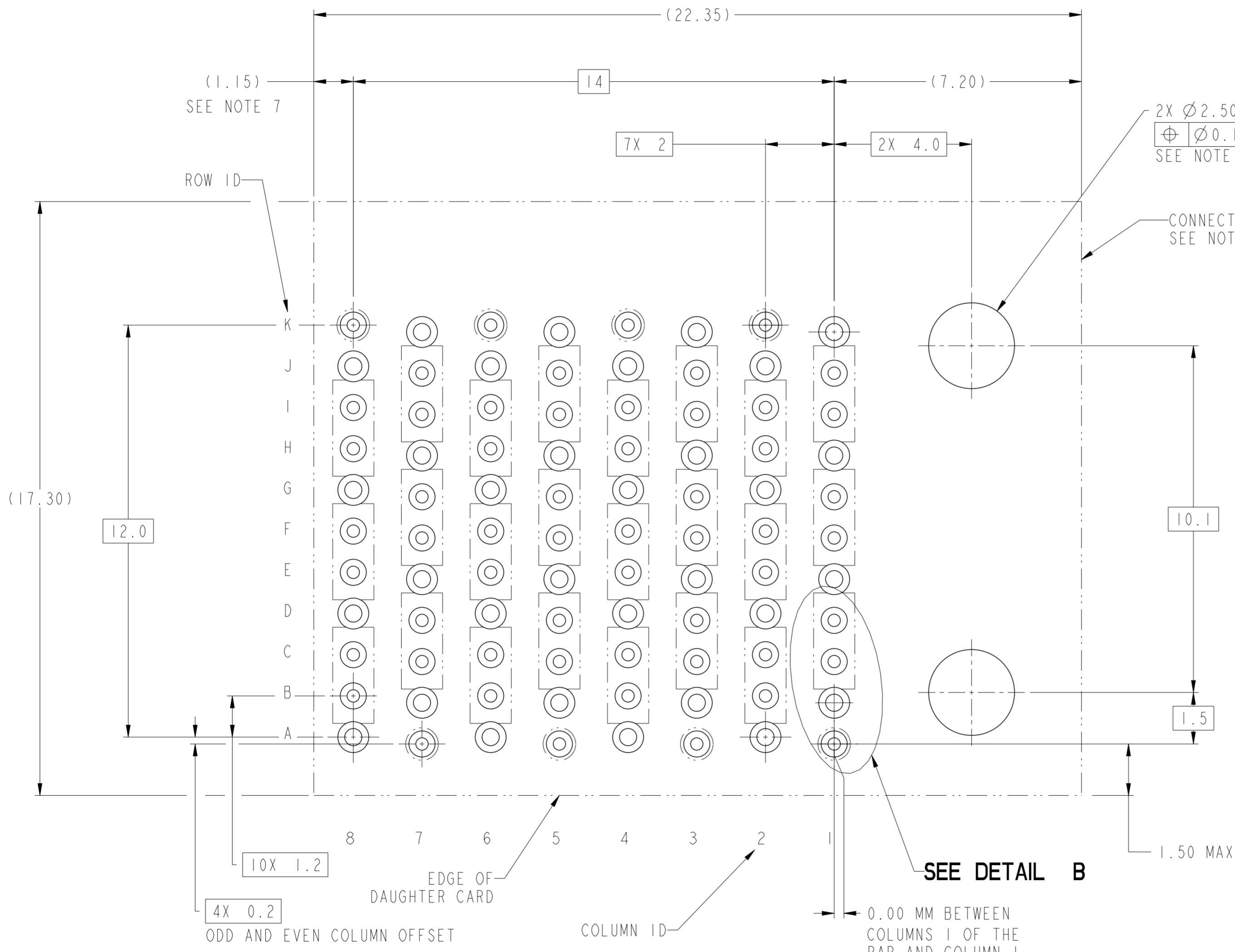

**DETAIL B**  
SCALE 20:1

**10124308-Y1ALF THRU -Y1JLF**  
**RECOMMENDED PCB LAYOUT**  
**COMPONENT SIDE**  
**NOTES 7, 8, 9, 11 & 16**  
**SCALE 10:1**

spec ref	SEE NOTES	dr	Heaven Cen	2013/05/14	projection	MM	size	A2	scale	7:1
tolerance std	TOLERANCES UNLESS OTHERWISE SPECIFIED	eng	Terry Luo	2016/04/12			ecn no	-	rel level	Preliminary
ASME Y14.5M		chr	-	appr						
surface	linear	0.X	±.3		product family		ExaMAX	title ExaMAX R.A. RECEPTACLE ASS'Y, 3 PR, 88 POS, 8 IMLA cat. no.	dwg no 10124308	rev 12
		0.XX	±.10		Product - Customer Drw		sheet 7 of 10			
	angular	0°	±°							

Amphenol  
FCi

© 2016 AFci

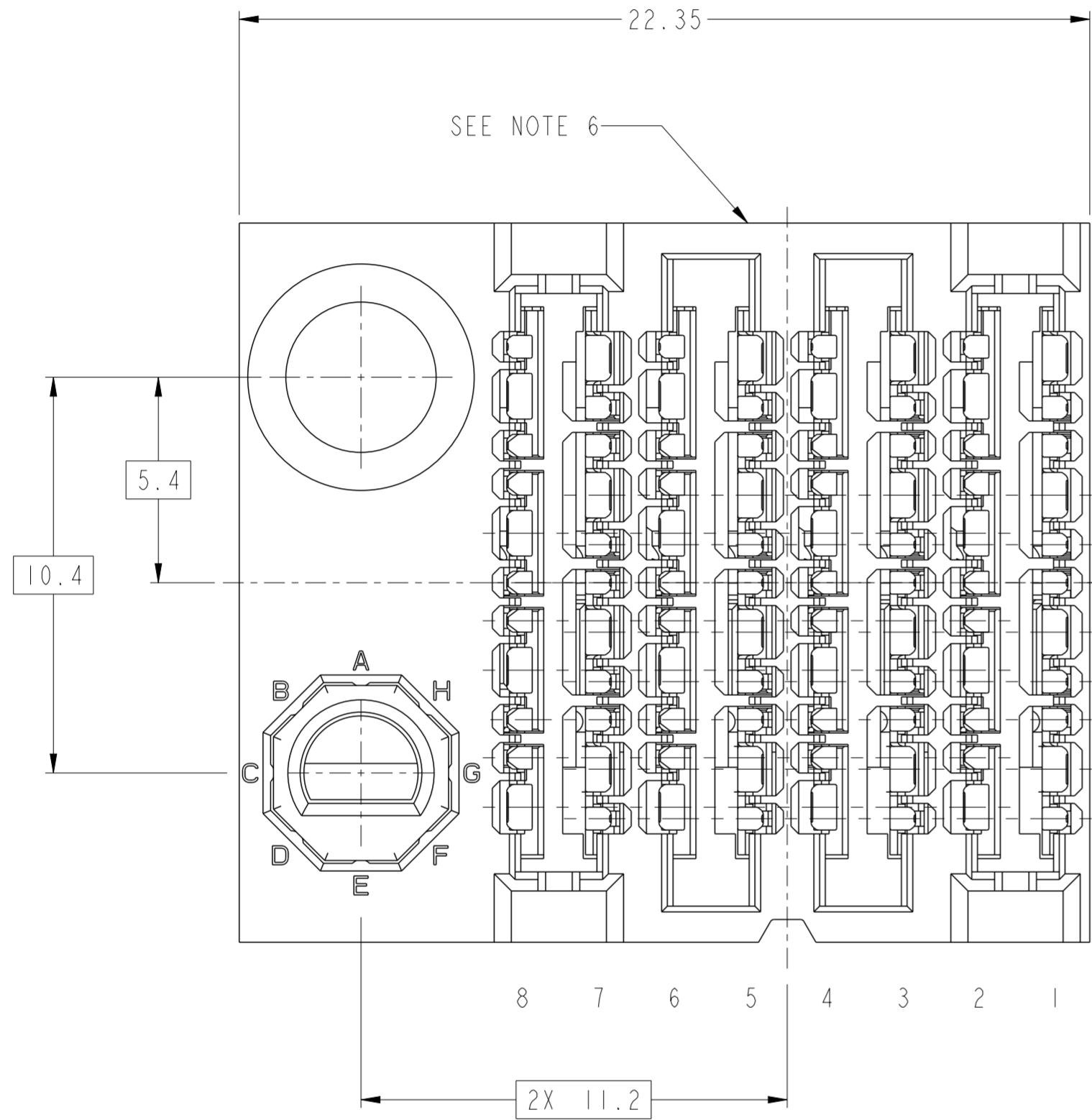

K  
J  
I  
H  
G  
F  
E  
D  
C  
B  
A

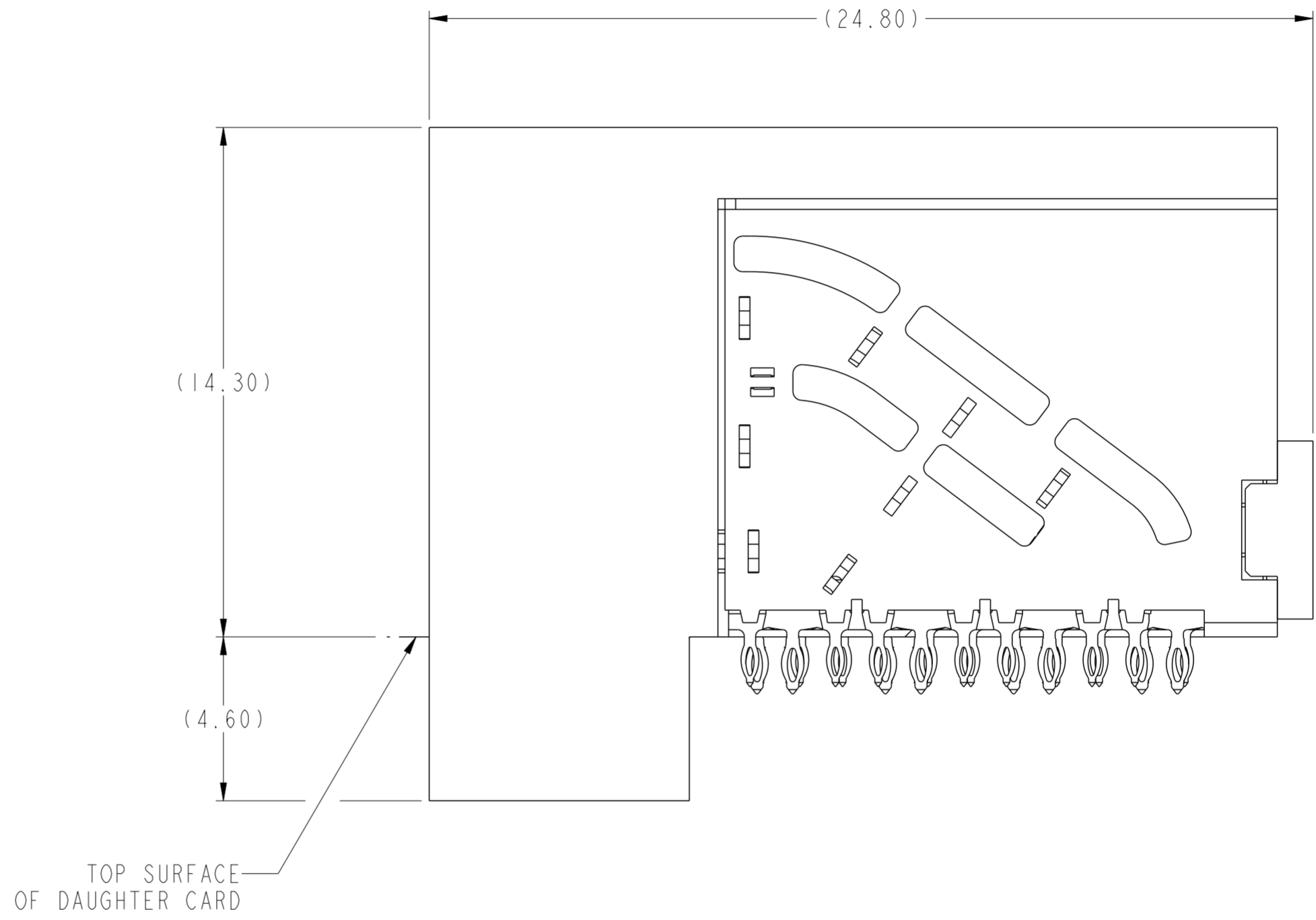

10124308-Y2ALF THRU -Y2JLF  
LEFT GUIDANCE (SEE NOTE 17)  
FOR ALL OTHER DIMENSIONS SEE SHEET 1

Amphenol  
FCi

© 2016 AFCi

spec ref	SEE NOTES	dr	Heaven Cen	2013/05/14	projection	MM	size	A2	scale	7:1	
tolerance std	TOLERANCES UNLESS OTHERWISE SPECIFIED	eng	Terry Luo	2016/04/12			ecn no	-	rel level		
ASME Y14.5M		chr	-	-			rel level	Preliminary			
surface	linear	0.X	±.3		product family	ExaMAX	rel level	Preliminary	rev		
	0.XX	±.10	<b>Amphenol FCI</b>		title	ExaMAX R.A. RECEPTACLE	dwg no	10124308	12		
	0.XXX	±.050	ASS'Y, 3 PR, 88 POS, 8 IMLA		cat. no.	Product - Customer Drw	sheet 8 of 10				
	angular	0°	±°								



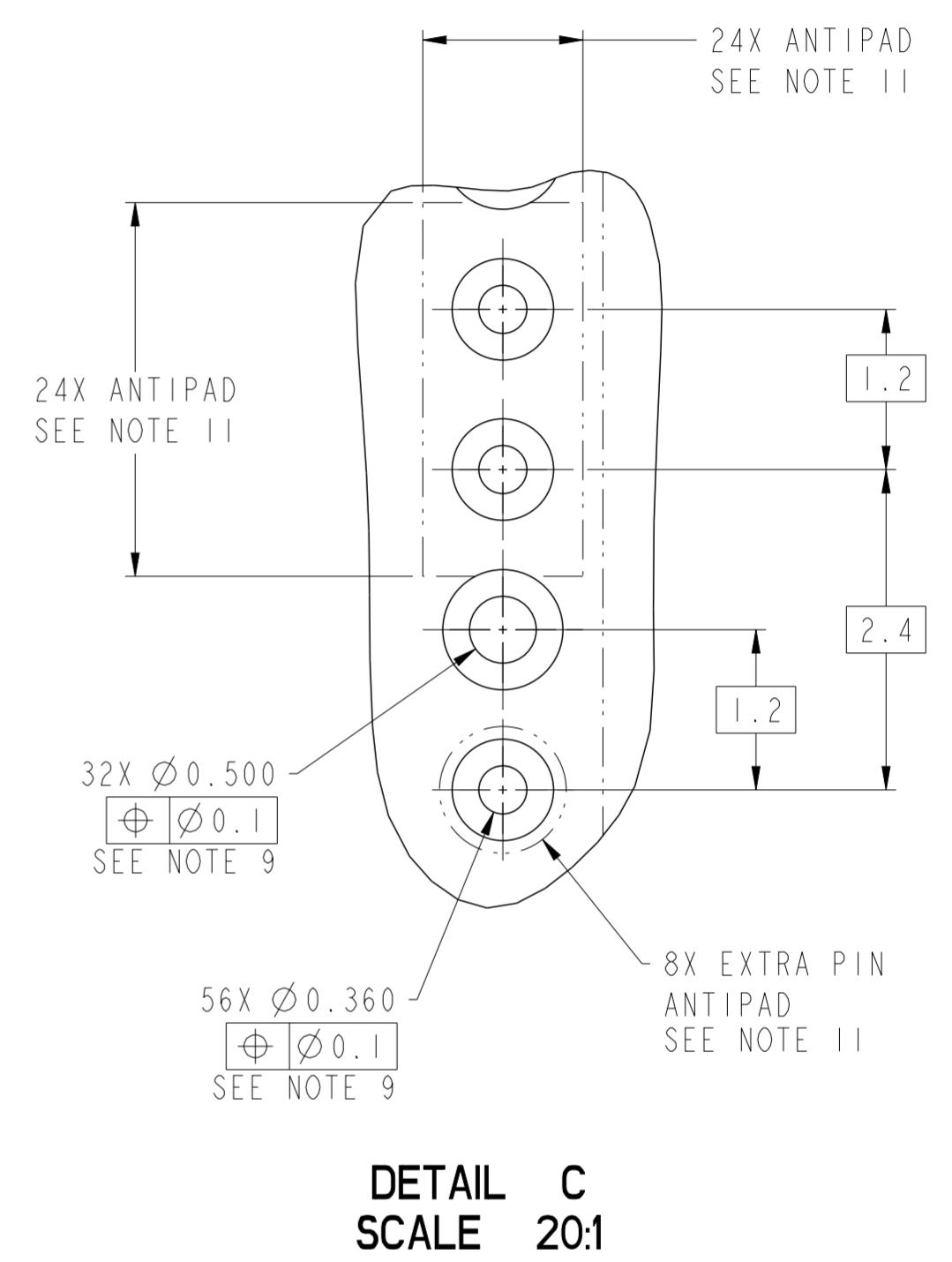
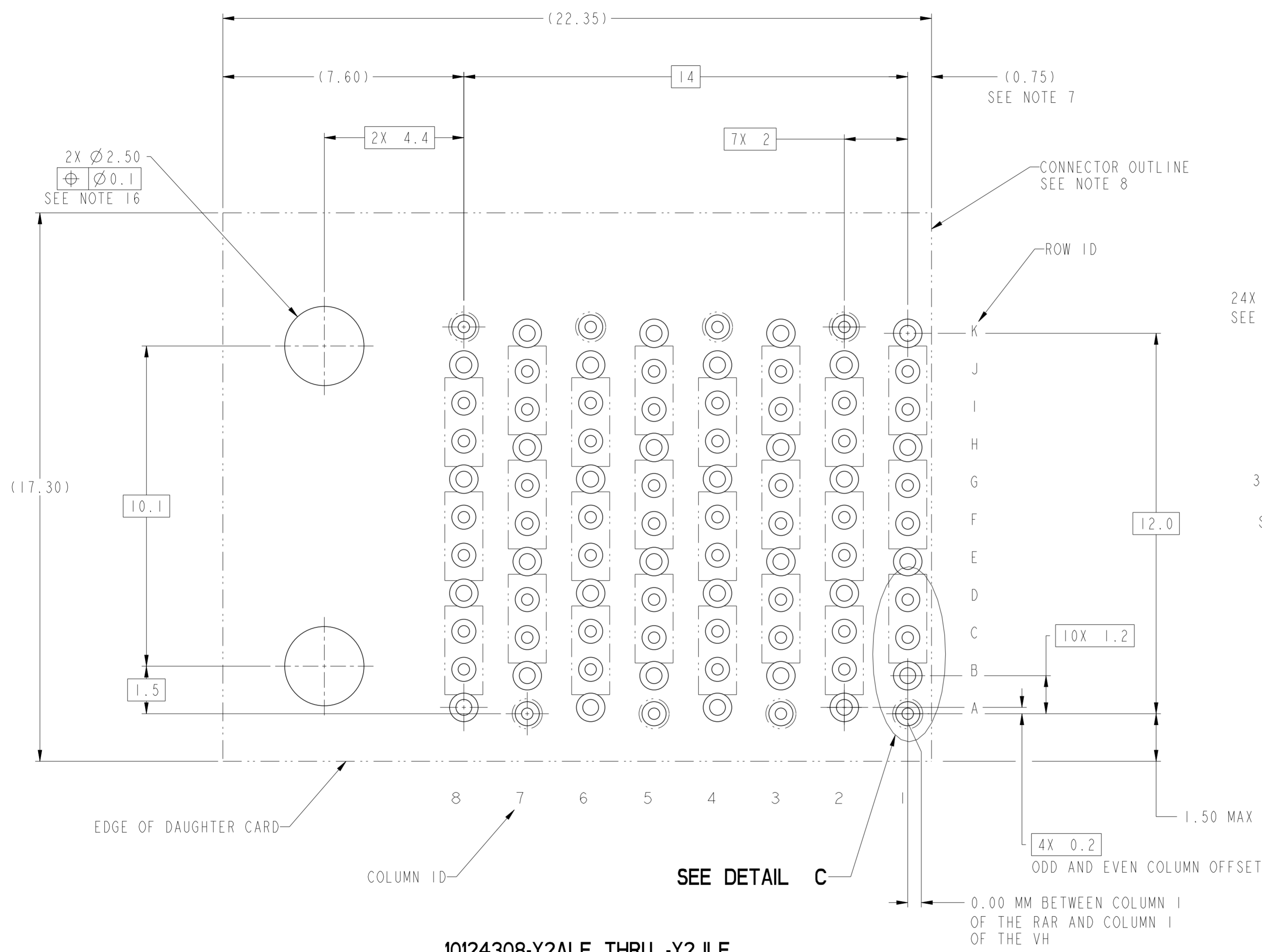

10124308-Y2ALF THRU -Y2JLF  
RECOMMENDED PCB LAYOUT  
COMPONENT SIDE  
NOTES 7, 8, 9, 11 & 16  
SCALE 10:1

spec ref	SEE NOTES	dr	Heaven Cen	2013/05/14	projection	MM	size	A2	scale	7:1	
tolerance std	TOLERANCES UNLESS OTHERWISE SPECIFIED	eng	Terry Luo	2016/04/12			ecn no	-	rel level	Preliminary	
ASME Y14.5M		chr	-	appr							-
surface	linear	0.X	±.3	<b>Amphenol FCI</b>		title ExaMAX R.A. RECEPTACLE ASS'Y, 3 PR, 88 POS, 8 IMLA		dwg no 10124308		rev 12	
		0.XX	±.10								
		0.XXX	±.050								
	angular	0°	±°	cat. no.		Product - Customer Drw		sheet 9 of 10			

1 0 1 2 4 3 0 8 - Y Y Y L F

ASSEMBLY PART NUMBER	DESCRIPTION
10124308-1YYLF	STANDARD MATE
10124308-2YYLF	ADVANCED MATE
10124308-3YYLF	SHORT DETECT
10124308-4YYLF	ADVANCED MATE & SHORT DETECT

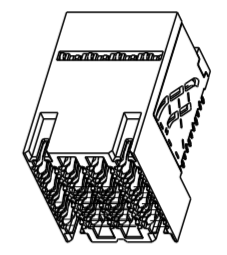
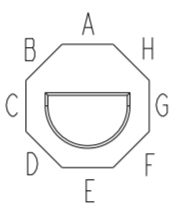
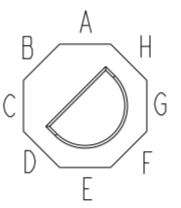
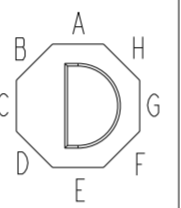
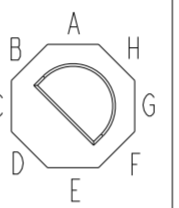
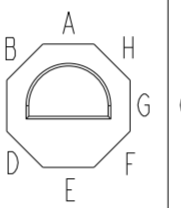
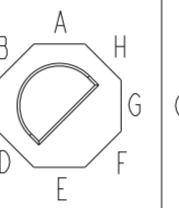
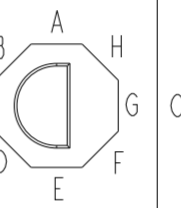
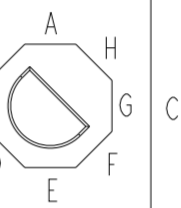
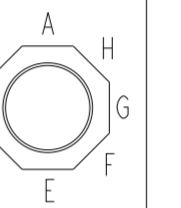
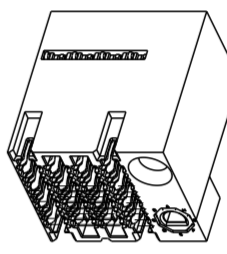
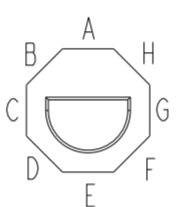
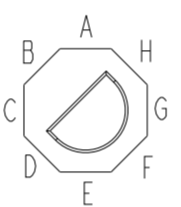
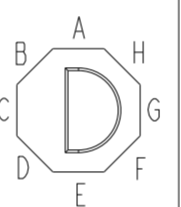
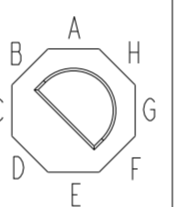
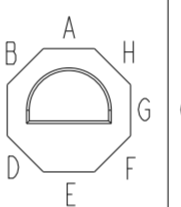
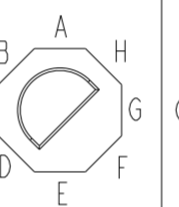
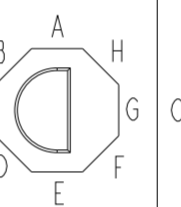
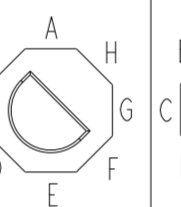
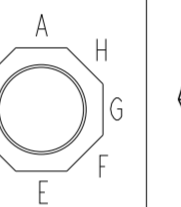
MODULE DESCRIPTION	DESIGNATION REPRESENTED IN DASH NUMBER										BASE MODULE
	1A	1B	1C	1D	1E	1F	1G	1H	1J (NO KEY)		
WITHOUT END GUIDES MODULE (SEE SHEET 1)	01										
RIGHT GUIDANCE MODULE (SEE SHEET 6)											
	LEFT GUIDANCE MODULE (SEE SHEET 8)										

NOTES:

- 1 - CONNECTOR MATERIALS:  
HOUSING: HIGH TEMP THERMOPLASTIC, BLACK, UL94-V0  
IMLA PLASTIC: HIGH TEMP THERMOPLASTIC, BLACK, UL94-V0  
CONTACT: COPPER ALLOY  
ORGANIZER: HIGH TEMP THERMOPLASTIC, BLACK, UL94-V0
- 2 - CONTACT PLATING:  
SEPARABLE INTERFACE:  
PERFORMANCE-BASED PLATING, QUALIFIED TO MEET THE REQUIREMENTS OF FCI PRODUCT SPECIFICATION GS-12-1096 INCLUDING TELCORDIA GR-1217-CORE (NOVEMBER 1995) CENTRAL OFFICE TEST SEQUENCE  
  
PRESS-FIT TAILS: TIN OVER NICKEL (LEAD FREE)
- 3 - PRODUCT SPECIFICATION: GS-12-1096
- 4 - APPLICATION SPECIFICATION GS-20-0361.
- 5 - PACKAGING MEETS GS-14-920 LEAD FREE LABELING SPECIFICATION.
- 6 - PRODUCT MARKING, (PROTOTYPE, PART NUMBER & LOT CODE), ON THIS SURFACE.
- 7 - THE MINIMUM VIA SPACING BETWEEN STACKED CONNECTORS IS 2.0 mm FOR THIS RAR AND THE MATING HEADER. REFER TO THE APPLICATION SPECIFICATION FOR DETAILS.
- 8 - CONNECTOR OUTLINE MAY BE SCREEN PRINTED ONTO CUSTOMER PCB TO BE USED AS A GUIDE FOR MANUAL CONNECTOR PLACEMENT.
- 9 - REFER TO CUSTOMER DRAWING 10119933 FOR INFORMATION ON PCB HOLE DIAMETERS AND PLATING OPTIONS
- 10 - THIS PRODUCT MEETS THE EUROPEAN UNION DIRECTIVES & OTHER COUNTRY REGULATIONS AS DESCRIBED IN GS-47-0004.
- 11 - REFER TO APPLICATION SPECIFICATION FOR TRACE ROUTING EXAMPLES THAT INCLUDE DIMENSIONS FOR ANTIPADS, TRACE WIDTH, TRACE SPACING, ETC.
- 12 - THE HOUSING WILL WITHSTAND EXPOSURE TO 260° C FOR 10-30 SECONDS IN A CONVECTION, INFRA-RED OR VAPOR PHASE REFLOW OVEN.
- 13 - THE ADVANCED MATE RECEPTACLE, 10124308-2XXLF, WHEN MATED WITH AN ADVANCED MATE VERTICAL HEADER OR AN ADVANCED MATE RIGHT-ANGLE HEADER WILL PROVIDE 2 PAIRS OF MATING CONTACTS THAT MATE 0.75MM BEFORE THE REMAINDER OF THE SIGNAL AND GROUND CONTACTS.

- 14 - THE SHORT DETECT RECEPTACLE, 10124308-3XXLF, WHEN MATED WITH A STANDARD MATE VERTICAL HEADER OR A STANDARD MATE RIGHT-ANGLE HEADER WILL PROVIDE 1 PAIR OF MATING CONTACTS THAT MATE 1.00MM AFTER THE REMAINDER OF THE SIGNAL AND GROUND CONTACTS.
- 15 - THE ADVANCE MATE/SHORT DETECT RECEPTACLE, 10124308-4XXLF, WHEN MATED WITH AN ADVANCED MATE VERTICAL HEADER OR AN ADVANCED MATE RIGHT-ANGLE HEADER WILL PROVIDE 2 PAIRS OF MATING CONTACTS THAT MATE 0.75MM BEFORE THE REMAINDER OF THE SIGNAL AND GROUND CONTACTS AND 1 PAIR OF MATING CONTACTS THAT MATE 1.00MM AFTER THE REMAINDER OF THE SIGNAL AND GROUND CONTACTS.
- 16 - FOR CONNECTORS WITH EITHER A RIGHT OR LEFT GUIDE MODULE, TWO PHILLIPS PAN HEAD M2 HOLD DOWN SCREW MUST BE USED TO SECURE THE CONNECTOR TO THE PCB. THE SCREW LENGTH SHALL BE 2.0-6.0mm PLUS THE THICKNESS OF THE BOARD
- 17 - LEFT / RIGHT INTEGRATED GUIDE ORIENTATION IS DETERMINED BY THE LOCATION OF THE GUIDE FEATURE WHEN LOOKING AT THE MATING FACE OF THE RIGHT ANGLE RECEPTACLE THAT IT MATES WITH (i. e. A RIGHT GUIDE VERTICAL HEADER MATES WITH A RIGHT GUIDE RIGHT ANGLE RECEPTACLE.)
- 18 - ALL GROUND CONTACTS ARE COMMONED WITHIN A COLUMN.

Amphenol FCI

© 2016 AFCI

spec ref	SEE NOTES	dr	Heaven Cen	2013/05/14	projection	MM	size	A2	scale	1:1	
tolerance std	TOLERANCES UNLESS OTHERWISE SPECIFIED	eng	Terry Luo	2016/04/12		← →	ecn no	-	rel level	Preliminary	
ASME Y14.5M		chr	-	appr			-	product family		ExaMAX	
surface	linear	0.X	±.3	<b>Amphenol FCI</b>	title		ExaMAX R.A. RECEPTACLE		dwg no	10124308	
		0.XX	±.10		+ title		ASS'Y, 3 PR, 88 POS, 8 IMLA			rev	12
		0.XXX	±.050		cat. no.		Product - Customer Drw			sheet	10 of 10
	angular	0°	±°								