

Tous droits strictement réservés. Reproduction ou communication a des tiers interdite sous quelque forme que ce soit sans autorisation écrite du propriétaire. Propriété de c.FCI. Droits de reproduction FCI.

All rights strictly reserved. Reproduction or issue to third parties in any form whatever is not permitted without written authority from the proprietor. Property of FCI. Copyright FCI.

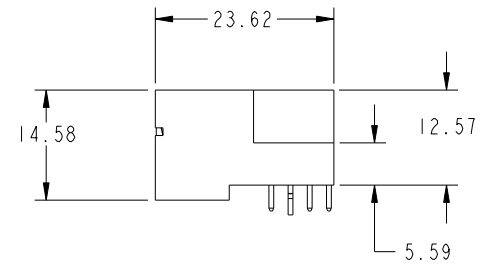
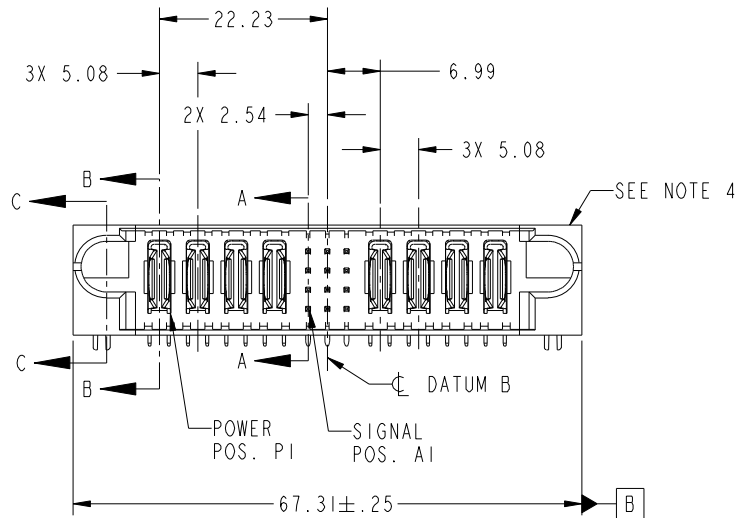
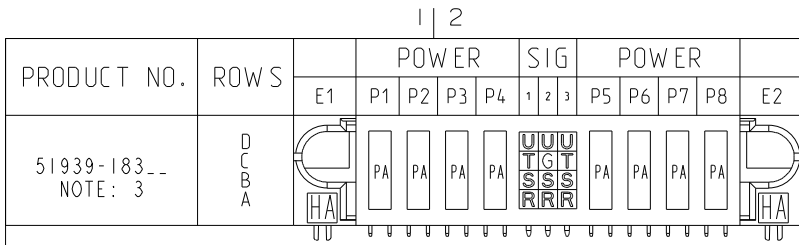

CODE	DIM "M" MATING LENGTH	CONTACT TYPE
U	[6.86]	SIGNAL
T	[6.86]	SIGNAL
S	[6.86]	SIGNAL
R	[6.86]	SIGNAL
G	[5.59]	SIGNAL
PA	[N/A]	POWER
HA	[N/A]	HOLD-DOWN

mat'l code				SEE NOTE		tolerances unless otherwise specified		CUSTOMER		
lir	ecn no.	dr	date	linear	0.X ± 0.5	COPY		www.fciconnect.com title 4P +12S +4P RIGHT ANGLE SOLDER HEADER		
A	DG05-0108	GuoJM	5/11/05		0.XX ± 0.25	projection				
B	DG06-0001	RYAN	01/04/06	angles	0.XXX ± 0.10			product family PwrBlade code 213		
C	DG07-0498	JW	09/13/08		0° ± 2°			size dwg no		sheet 1 of 4
				dr	SLU0	5/11/05	scale		A 51939-183	
				enrg	SLU0	5/11/05	1:1			
				chr	VICTOR LIN	5/11/05				
				appd	JOSEPH HSIA	5/11/05				
sheet index	revision sheet	C 1	C 2	C 3	C 4					

A

B

1 | 2

3 |

4

A

B

Pro/E

PDM: Rev: C

STAT: Released

Printed: Dec 20, 2010

cage code 28556

Tous droits strictement réservés. Reproduction ou communication a des tiers interdite sous quelque forme que ce soit sans autorisation écrite du propriétaire. Propriété de c.FCI. Droits de reproduction FCI.

All rights strictly reserved. Reproduction or issue to third parties in any form whatever is not permitted without written authority from the proprietor. Property of FCI. Copyright FCI.



PRODUCT NUMBER

51939-183--
NOTE: 3

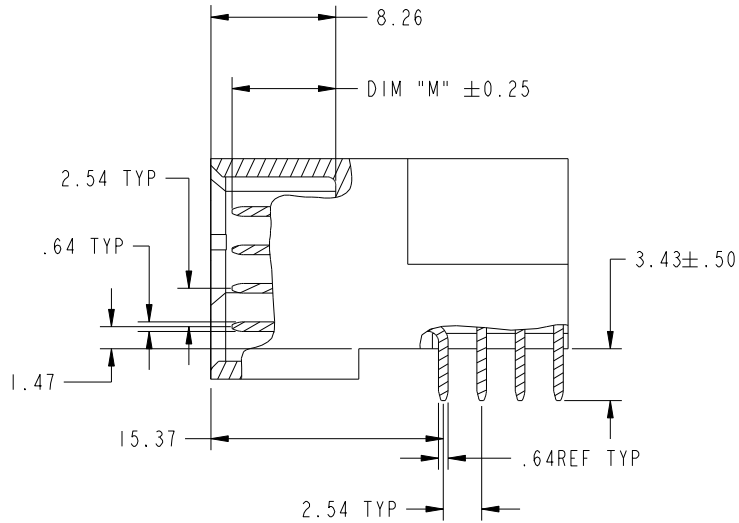

BROKEN-OUT SECTION A-A
SCALE 2:1

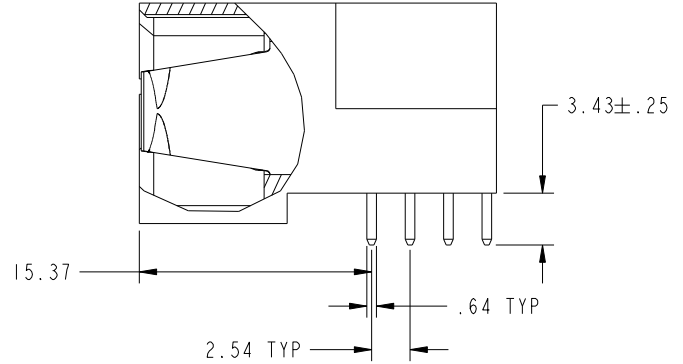

BROKEN-OUT SECTION B-B
SCALE 2:1

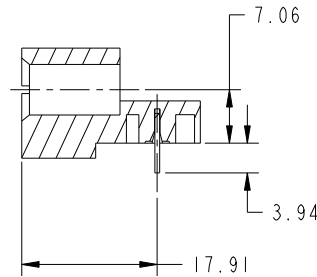

SECTION C-C

mat'l code		SEE NOTE		tolerances unless otherwise specified		CUSTOMER		www.fciconnect.com	
lir	ecn no.	dr	date	linear	0.X ±0.5	COPY		title	
C				linear	0.XX ±0.25	projection		4P +12S +4P	
				angles	0.XXX ±0.10			RIGHT ANGLE SOLDER HEADER	
				dr	0° ±2°			product family	
				enr	SLU0 5/11/05	MM		PwrBlade	
				chr	SLU0 5/11/05	1:1		code	
				appd	VICTOR LIN 5/11/05			213	
					JOSEPH HSIA 5/11/05			sheet	
sheet index	revision sheet							2	
								A 51939-183	

cage code 28506

Pro/E

PDM: Rev: C

STATUS: Released

Printed: Dec 20, 2010

Tous droits strictement réservés. Reproduction ou communication a des tiers interdite sous quelque forme que ce soit sans autorisation écrite du propriétaire. Propriété de c.FCI. Droits de reproduction FCI.

All rights strictly reserved. Reproduction or issue to third parties in any form whatever is not permitted without written authority from the proprietor. Property of FCI. Copyright FCI.



PRODUCT NUMBER

51939-183--
NOTE: 3

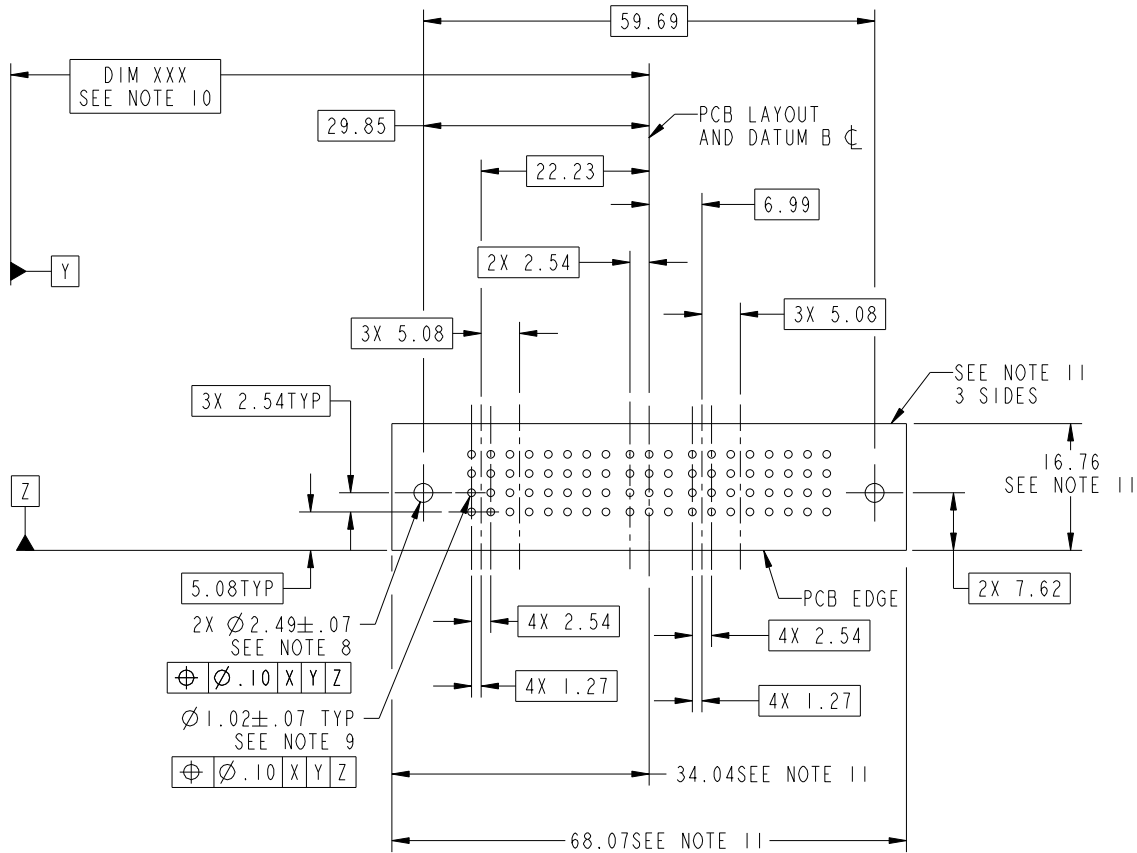

RECOMMENDED PCB LAYOUT

mat'l code		SEE NOTE		tolerances unless otherwise specified		CUSTOMER		 www.fciconnect.com	
lir	ecn no.	dr	date	linear	0.X ±0.5	COPY		title	
C				angles	0.XX ±0.25	projection		4P +12S +4P	
					0.XXX ±0.10			RIGHT ANGLE SOLDER HEADER	
				dr	0° ±2°			product family	
				engr	SLU0 5/11/05	MM		PwrBlade	
				chr	SLU0 5/11/05			code	
				appd	VICTOR LIN 5/11/05	scale		213	
					JOSEPH HSIA 5/11/05	1:1		sheet	
sheet index	revision sheet							3	
								A 51939-183	

cage code 2856

Tous droits strictement reserves. Reproduction ou communication a des tiers interdite sous quelque forme que ce soit sans autorisation ecrite du proprietaire. Propriete de c.FCI. Droits de reproduction FCI.

All rights strictly reserved. Reproduction or issue to third parties in any form whatever is not permitted without written authority from the proprietor. Property of FCI. Copyright FCI.



1 | 2

3

4

PRODUCT NUMBER
51939-183--
NOTE: 3

NOTES:

1. DIMENSIONS AND TOLERANCES ARE IN ACCORDANCE WITH ASME Y14.5M, 1994 UNLESS OTHERWISE SPECIFIED.

CONNECTOR NOTES:

- 2. HOUSING MATERIAL: UL 94 V-0 GLASS FILLED HIGH-TEMP THERMOPLASTIC
POWER CONTACT MATERIAL: COPPER ALLOY
SIGNAL PIN MATERIAL: COPPER ALLOY
 - 3. PLATING:
SEE ITEM 1 & 2 IN PRINT 10064183 FOR PLATING SPEC OF 51939-183; 51939-183LF PRESPECTIVELY
 - 4. MANUFACTURER'S NAME, P/N, AND DATE CODE TO APPEAR ON THIS SURFACE.
 - 5. PRODUCT SPECIFICATION GS-12-149.
APPLICATION SPECIFICATION BUS-20-067.
 - 6. PACKAGED IN TRAYS.
- PCB NOTES:
- 7. ALL HOLE DIAMETERS ARE FINISHED HOLE SIZE.
 - 8. MOUNTING HOLES, WHERE APPLICABLE, ARE UNPLATED.
 - 9. $\varnothing 1.151 \pm 0.025$ DRILLED HOLES PLATED WITH)
0.008 MIN SnPb OR Sn OVER 0.03
TO 0.08 Cu PLATING TO ACHIEVE
 $\varnothing 1.02 \pm .07$ HOLE.
 - 10. "DIM XXX" TO BE DETERMINED BY THE CUSTOMER.
 - 11. CONNECTOR KEEP-OUT ZONE.
 - 12. A \triangle SYMBOL WILL BE NEXT TO ANY DIMENSION, VIEW, OR NOTE WHICH HAS BEEN MODIFIED WITH THE CURRENT DRAWING REVISION.

A

A

B

B

mat'l code		SEE NOTE		tolerances unless otherwise specified		CUSTOMER		www.fciconnect.com	
lfr	ecn no.	dr	date	linear	0.X ± 0.5	COPY		title	
C					0.XX ± 0.25	projection		4P +12S +4P	
				angles	0.XXX ± 0.10			RIGHT ANGLE SOLDER HEADER	
					0° $\pm 2°$			product family PwrBlade code	
				dr	SLU0 5/11/05	MM		size dwg no	
				enrg	SLU0 5/11/05			213	
				chr	VICTOR LIN 5/11/05	scale		sheet	
				appd	JOSEPH HSIA 5/11/05	1:1		4	
sheet index	revision sheet							A 51939-183	

1 | 2

Pro/E

PDM: Rev: C

STAT: Released

Printed: Dec 20, 2010

cage code 28506

4