



KSZ9031MNX

Gigabit Ethernet Transceiver with GMII/MII Support

Data Sheet Rev. 1.0

General Description

The KSZ9031MNX is a completely integrated triple-speed (10Base-T/100Base-TX/1000Base-T) Ethernet physical-layer transceiver for transmission and reception of data on standard CAT-5 unshielded twisted pair (UTP) cable.

The KSZ9031MNX offers the industry-standard GMII/MII (Gigabit Media Independent Interface / Media Independent Interface) for connection to GMII/MII MACs in Gigabit Ethernet processors and switches for data transfer at 1000Mbps or 10/100Mbps.

The KSZ9031MNX reduces board cost and simplifies board layout by using on-chip termination resistors for the four differential pairs and by integrating an LDO controller to drive a low-cost MOSFET to supply the 1.2V core.

The KSZ9031MNX offers diagnostic features to facilitate system bring-up and debugging in production testing and in product deployment. Parametric NAND tree support enables fault detection between KSZ9031MNX I/Os and the board. The LinkMD[®] TDR-based cable diagnostic identifies faulty copper cabling. Remote and local loopback functions verify analog and digital data paths.

The KSZ9031MNX is available in a 64-pin, lead-free QFN package (see "Ordering Information").

Data sheets and support documentation are available on Micrel's web site at: www.micrel.com.

Features

- Single-chip 10/100/1000Mbps IEEE 802.3 compliant Ethernet transceiver
- GMII/MII standard interface with 3.3V/2.5V/1.8V tolerant I/Os
- Auto-negotiation to automatically select the highest link-up speed (10/100/1000Mbps) and duplex (half/full)
- On-chip termination resistors for the differential pairs
- On-chip LDO controller to support single 3.3V supply operation – requires only one external FET to generate 1.2V for the core
- Jumbo frame support up to 16KB
- 125MHz reference clock output
- Energy-detect power-down mode for reduced power consumption when the cable is not attached
- Energy Efficient Ethernet (EEE) support with low-power idle (LPI) mode and clock stoppage for 100Base-TX/1000Base-T and transmit amplitude reduction with 10Base-Te option
- Wake-on-LAN (WOL) support with robust custom-packet detection

Functional Diagram

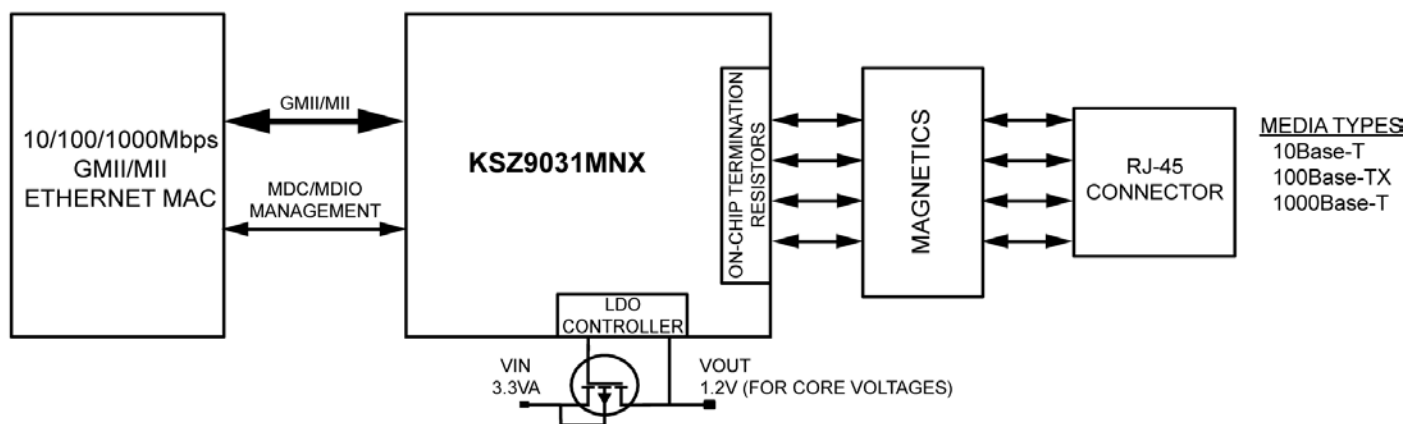

LinkMD is a registered trademark of Micrel, Inc.

Micrel Inc. • 2180 Fortune Drive • San Jose, CA 95131 • USA • tel +1 (408) 944-0800 • fax +1 (408) 474-1000 • <http://www.micrel.com>

Features (Continued)

- Programmable LED outputs for link, activity, and speed
- Baseline wander correction
- LinkMD TDR-based cable diagnostic to identify faulty copper cabling
- Parametric NAND tree support to detect faults between chip I/Os and board.
- Loopback modes for diagnostics
- Automatic MDI/MDI-X crossover to detect and correct pair swap at all speeds of operation
- Automatic detection and correction of pair swaps, pair skew, and pair polarity
- MDC/MDIO management interface for PHY register configuration
- Interrupt pin option
- Power-down and power-saving modes
- Operating voltages
 - Core (DVDDL, AVDDL, AVDDL_PLL): 1.2V (external FET or regulator)
 - VDD I/O (DVDDH): 3.3V, 2.5V, or 1.8V
 - Transceiver (AVDDH): 3.3V or 2.5V (commercial temp)
- Available in a 64-pin QFN (8mm x 8mm) package

Applications

- Laser/Network printer
- Network attached storage (NAS)
- Network server
- Broadband gateway
- Gigabit SOHO/SMB router
- IPTV
- IP set-top box
- Game console
- IP camera
- Triple-play (data, voice, video) media center
- Media converter

Ordering Information

Part Number	Temperature Range	Package	Lead Finish	Wire Bonding	Description
KSZ9031MNXCA	0°C to 70°C	64-Pin QFN	Pb-Free	Gold	GMII/MII, Commercial Temperature, Gold Wire Bonding
KSZ9031MNXCC ⁽¹⁾	0°C to 70°C	64-Pin QFN	Pb-Free	Copper	GMII/MII, Commercial Temperature, Copper Wire Bonding
KSZ9031MNXIA ⁽¹⁾	-40°C to 85°C	64-Pin QFN	Pb-Free	Gold	GMII/MII, Industrial Temperature, Gold Wire Bonding
KSZ9031MNXIC ⁽¹⁾	-40°C to 85°C	64-Pin QFN	Pb-Free	Copper	GMII/MII, Industrial Temperature, Copper Wire Bonding
KSZ9031MNX-EVAL	0°C to 70°C	64-Pin QFN	Pb-Free		KSZ9031MNX Evaluation Board (Mounted with KSZ9031MNX device in commercial temperature)

Note:

1. Contact factory for lead time.

Revision History

Revision	Date	Summary of Changes
1.0	10/31/12	Data sheet created

Contents

General Description	1
Features	1
Functional Diagram	1
Features (Continued)	2
Applications	2
Ordering Information	2
Revision History	3
Contents	4
List of Figures.....	7
List of Tables.....	8
Pin Configuration.....	9
Pin Description	10
Strapping Options	16
Functional Overview.....	17
Functional Description: 10Base-T/100Base-TX Transceiver.....	18
100Base-TX Transmit.....	18
100Base-TX Receive.....	18
Scrambler/De-Scrambler (100Base-TX only)	18
10Base-T Transmit.....	18
10Base-T Receive.....	18
Functional Description: 1000Base-T Transceiver	19
Analog Echo-Cancellation Circuit	19
Automatic Gain Control (AGC)	19
Analog-to-Digital Converter (ADC)	20
Timing Recovery Circuit	20
Adaptive Equalizer.....	20
Trellis Encoder and Decoder	20
Functional Description: Additional 10/100/1000 PHY Features.....	20
Pair-Swap, Alignment, and Polarity Check	21
Wave Shaping, Slew-Rate Control, and Partial Response	21
PLL Clock Synthesizer	21
Auto-Negotiation	21
GMII Interface.....	23
GMII Signal Definition.....	24
GMII Signal Diagram	24
MII Interface	25
MII Signal Definition.....	26
MII Signal Diagram.....	26
MII Management (MIIM) Interface.....	27
Interrupt (INT_N)	27

LED Mode	27
Single-LED Mode	27
Tri-color Dual-LED Mode	28
Loopback Mode	28
Local (Digital) Loopback	28
Remote (Analog) Loopback	29
LinkMD [®] Cable Diagnostic	30
NAND Tree Support	30
Power Management	31
Energy-Detect Power-Down Mode	31
Software Power-Down Mode	31
Chip Power-Down Mode	31
Energy Efficient Ethernet (EEE)	32
Transmit Direction Control (MAC-to-PHY)	32
Receive Direction Control (PHY-to-MAC)	33
Registers Associated with EEE	34
Wake-On-LAN	35
Magic-Packet Detection	35
Customized-Packet Detection	35
Link Status Change Detection	36
Typical Current/Power Consumption	37
Transceiver (3.3V), Digital I/Os (3.3V)	37
Transceiver (3.3V), Digital I/Os (1.8V)	37
Transceiver (2.5V), Digital I/Os (2.5V)	38
Transceiver (2.5V), Digital I/Os (1.8V)	38
Register Map	39
Standard Registers	41
IEEE Defined Registers – Descriptions	41
Vendor-Specific Registers – Descriptions	48
MMD Registers	51
MMD Registers – Descriptions	52
Absolute Maximum Ratings ⁽¹⁾	60
Operating Ratings ⁽²⁾	60
Electrical Characteristics ⁽³⁾	60
Timing Diagrams	63
GMII Transmit Timing	63
GMII Receive Timing	64
MII Transmit Timing	65
MII Receive Timing	66
Auto-Negotiation Timing	67
MDC/MDIO Timing	68
Power-Up/Power-Down/Reset Timing	69
Reset Circuit	70
Reference Circuits – LED Strap-In Pins	71

Reference Clock – Connection and Selection 72
Magnetic – Connection and Selection 73
Recommended Land Pattern 75
Package Information 76

List of Figures

Figure 1. KSZ9031MNX Block Diagram	17
Figure 2. KSZ9031MNX 1000Base-T Block Diagram – Single Channel	19
Figure 3. Auto-Negotiation Flow Chart.....	22
Figure 4. KSZ9031MNX GMII Interface	24
Figure 5. KSZ9031MNX MII Interface.....	26
Figure 6. Local (Digital) Loopback	29
Figure 7. Remote (Analog) Loopback	30
Figure 8. LPI Mode (Refresh Transmissions and Quiet Periods)	32
Figure 9. LPI Transition – GMII (1000Mbps) Transmit	33
Figure 10. LPI Transition – MII (100Mbps) Transmit	33
Figure 11. LPI Transition – GMII (1000Mbps) Receive	34
Figure 12. LPI Transition – MII (100Mbps) Receive	34
Figure 13. GMII Transmit Timing – Data Input to PHY	63
Figure 14. GMII Receive Timing – Data Input to MAC	64
Figure 15. MII Transmit Timing – Data Input to PHY	65
Figure 16. MII Receive Timing – Data Input to MAC	66
Figure 17. Auto-Negotiation Fast Link Pulse (FLP) Timing	67
Figure 18. MDC/MDIO Timing.....	68
Figure 19. Power-Up/Power-Down/Reset Timing	69
Figure 20. Recommended Reset Circuit.....	70
Figure 21. Recommended Reset Circuit for Interfacing with CPU/FPGA Reset Output	70
Figure 22. Reference Circuits for LED Strapping Pins.....	71
Figure 23. 25MHz Crystal/Oscillator Reference Clock Connection	72
Figure 24. Typical Gigabit Magnetic Interface Circuit	73
Figure 25. Recommended Land Pattern, 64-Pin (8mm x 8mm) QFN	75

List of Tables

Table 1. MDI/MDI-X Pin Mapping	20
Table 2. Auto-Negotiation Timers	23
Table 3. GMII Signal Definition	24
Table 4. MII Signal Definition	26
Table 5. MII Management Frame Format for the KSZ9031MNX.....	27
Table 6. Single-LED Mode – Pin Definition.....	28
Table 7. Tri-color Dual-LED Mode – Pin Definition	28
Table 8. NAND Tree Test Pin Order for KSZ9031MNX.....	31
Table 9. Typical Current/Power Consumption – Transceiver (3.3V), Digital I/Os (3.3V).....	37
Table 10. Typical Current/Power Consumption – Transceiver (3.3V), Digital I/Os (1.8V).....	37
Table 11. Typical Current/Power Consumption – Transceiver (2.5V), Digital I/Os (2.5V).....	38
Table 12. Typical Current/Power Consumption – Transceiver (2.5V), Digital I/Os (1.8V).....	38
Table 13. Standard Registers Supported by KSZ9031MNX.....	39
Table 14. MMD Registers Supported by KSZ9031MNX.....	40
Table 15. Portal Registers (Access to Indirect MMD Registers).....	51
Table 16. GMII Transmit Timing Parameters.....	63
Table 17. GMII Receive Timing Parameters.....	64
Table 18. MII Transmit Timing Parameters.....	65
Table 19. MII Receive Timing Parameters.....	66
Table 20. Auto-Negotiation Fast Link Pulse (FLP) Timing Parameters	67
Table 21. MDC/MDIO Timing Parameters	68
Table 22. Power-Up/Power-Down/Reset Timing Parameters	69
Table 23. Reference Crystal/Clock Selection Criteria.....	72
Table 24. Magnetics Selection Criteria	74
Table 25. Compatible Single-Port 10/100/1000 Magnetics	74

Pin Configuration

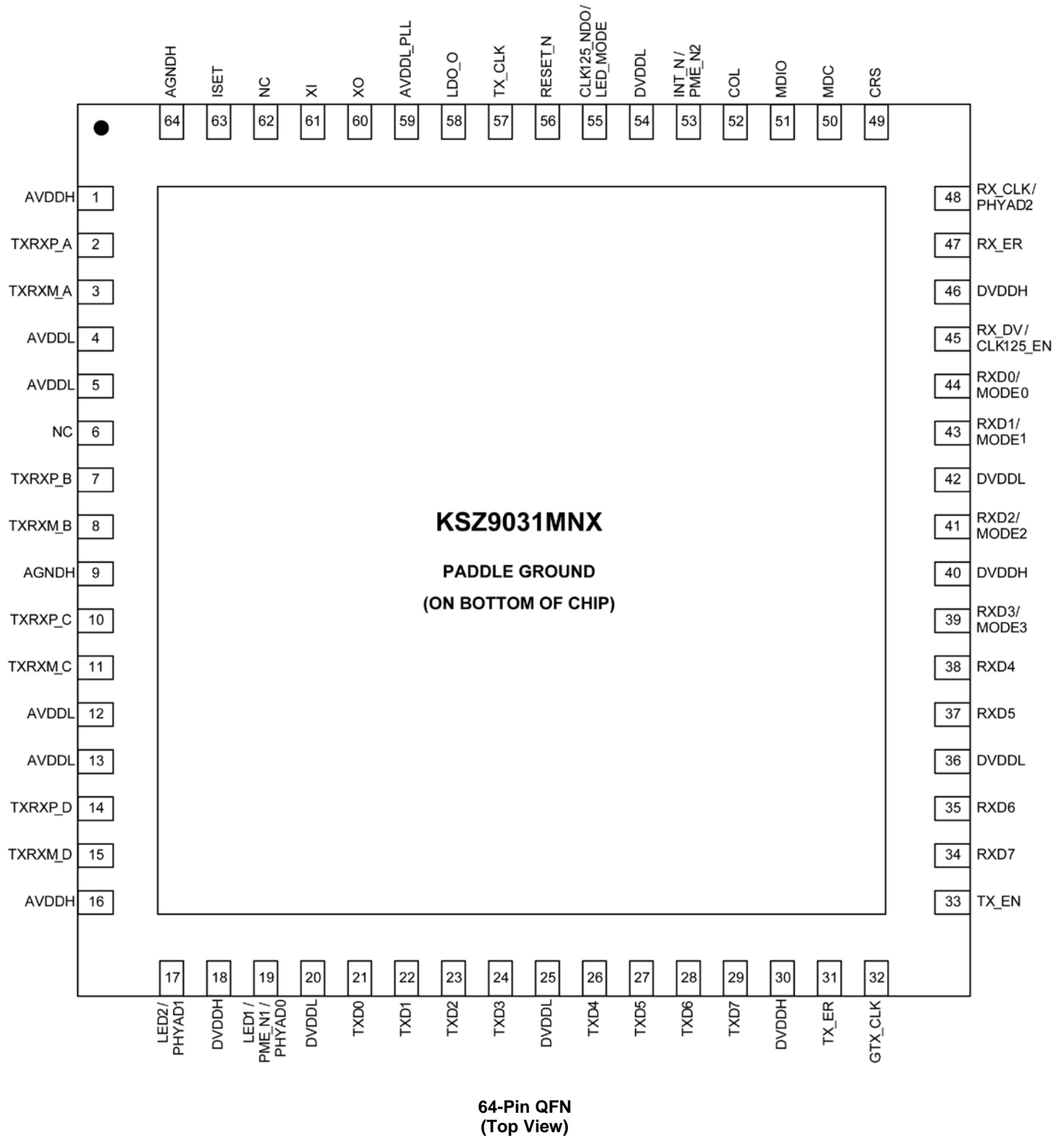

Pin Description

Pin Number	Pin Name	Type ⁽¹⁾	Pin Function
1	AVDDH	P	3.3V/2.5V (commercial temp only) analog V _{DD}
2	TXRXP_A	I/O	Media Dependent Interface[0], positive signal of differential pair 1000Base-T mode: TXRXP_A corresponds to BI_DA+ for MDI configuration and BI_DB+ for MDI-X configuration, respectively. 10Base-T/100Base-TX mode: TXRXP_A is the positive transmit signal (TX+) for MDI configuration and the positive receive signal (RX+) for MDI-X configuration, respectively.
3	TXRXM_A	I/O	Media Dependent Interface[0], negative signal of differential pair 1000Base-T mode: TXRXM_A corresponds to BI_DA– for MDI configuration and BI_DB– for MDI-X configuration, respectively. 10Base-T/100Base-TX mode: TXRXM_A is the negative transmit signal (TX–) for MDI configuration and the negative receive signal (RX–) for MDI-X configuration, respectively.
4	AVDDL	P	1.2V analog V _{DD}
5	AVDDL	P	1.2V analog V _{DD}
6	NC	–	No connect
7	TXRXP_B	I/O	Media Dependent Interface[1], positive signal of differential pair 1000Base-T mode: TXRXP_B corresponds to BI_DB+ for MDI configuration and BI_DA+ for MDI-X configuration, respectively. 10Base-T/100Base-TX mode: TXRXP_B is the positive receive signal (RX+) for MDI configuration and the positive transmit signal (TX+) for MDI-X configuration, respectively.
8	TXRXM_B	I/O	Media Dependent Interface[1], negative signal of differential pair 1000Base-T mode: TXRXM_B corresponds to BI_DB– for MDI configuration and BI_DA– for MDI-X configuration, respectively. 10Base-T/100Base-TX mode: TXRXM_B is the negative receive signal (RX–) for MDI configuration and the negative transmit signal (TX–) for MDI-X configuration, respectively.
9	AGNDH	Gnd	Analog ground
10	TXRXP_C	I/O	Media Dependent Interface[2], positive signal of differential pair 1000Base-T mode: TXRXP_C corresponds to BI_DC+ for MDI configuration and BI_DD+ for MDI-X configuration, respectively. 10Base-T/100Base-TX mode: TXRXP_C is not used.
11	TXRXM_C	I/O	Media Dependent Interface[2], negative signal of differential pair 1000Base-T mode: TXRXM_C corresponds to BI_DC– for MDI configuration and BI_DD– for MDI-X configuration, respectively. 10Base-T/100Base-TX mode: TXRXM_C is not used.

Pin Number	Pin Name	Type ⁽¹⁾	Pin Function																																																					
12	AVDDL	P	1.2V analog V _{DD}																																																					
13	AVDDL	P	1.2V analog V _{DD}																																																					
14	TXRXP_D	I/O	Media Dependent Interface[3], positive signal of differential pair 1000Base-T mode: TXRXP_D corresponds to BI_DD+ for MDI configuration and BI_DC+ for MDI-X configuration, respectively. 10Base-T/100Base-TX mode: TXRXP_D is not used.																																																					
15	TXRXM_D	I/O	Media Dependent Interface[3], negative signal of differential pair 1000Base-T mode: TXRXM_D corresponds to BI_DD- for MDI configuration and BI_DC- for MDI-X configuration, respectively. 10Base-T/100Base-TX mode: TXRXM_D is not used.																																																					
16	AVDDH	P	3.3V/2.5V (commercial temp only) analog V _{DD}																																																					
17	LED2/ PHYAD1	I/O	LED2 output: Programmable LED2 output Config mode: The voltage on this pin is sampled and latched during the power-up/reset process to determine the value of PHYAD[1]. See the “Strapping Options” section for details. The LED2 pin is programmed by the LED_MODE strapping option (pin 55), and is defined as follows: Single-LED Mode <table border="1" data-bbox="621 1003 1203 1119"> <thead> <tr> <th>Link</th> <th>Pin State</th> <th>LED Definition</th> </tr> </thead> <tbody> <tr> <td>Link off</td> <td>H</td> <td>OFF</td> </tr> <tr> <td>Link on (any speed)</td> <td>L</td> <td>ON</td> </tr> </tbody> </table> Tri-Color Dual-LED Mode <table border="1" data-bbox="621 1163 1430 1518"> <thead> <tr> <th rowspan="2">Link/Activity</th> <th colspan="2">Pin State</th> <th colspan="2">LED Definition</th> </tr> <tr> <th>LED2</th> <th>LED1</th> <th>LED2</th> <th>LED1</th> </tr> </thead> <tbody> <tr> <td>Link off</td> <td>H</td> <td>H</td> <td>OFF</td> <td>OFF</td> </tr> <tr> <td>1000 Link / No activity</td> <td>L</td> <td>H</td> <td>ON</td> <td>OFF</td> </tr> <tr> <td>1000 Link / Activity (RX, TX)</td> <td>Toggle</td> <td>H</td> <td>Blinking</td> <td>OFF</td> </tr> <tr> <td>100 Link / No activity</td> <td>H</td> <td>L</td> <td>OFF</td> <td>ON</td> </tr> <tr> <td>100 Link / Activity (RX, TX)</td> <td>H</td> <td>Toggle</td> <td>OFF</td> <td>Blinking</td> </tr> <tr> <td>10 Link / No activity</td> <td>L</td> <td>L</td> <td>ON</td> <td>ON</td> </tr> <tr> <td>10 Link / Activity (RX, TX)</td> <td>Toggle</td> <td>Toggle</td> <td>Blinking</td> <td>Blinking</td> </tr> </tbody> </table> For tri-color dual-LED mode, LED2 works in conjunction with LED1 (pin 19) to indicate 10Mbps link and activity.	Link	Pin State	LED Definition	Link off	H	OFF	Link on (any speed)	L	ON	Link/Activity	Pin State		LED Definition		LED2	LED1	LED2	LED1	Link off	H	H	OFF	OFF	1000 Link / No activity	L	H	ON	OFF	1000 Link / Activity (RX, TX)	Toggle	H	Blinking	OFF	100 Link / No activity	H	L	OFF	ON	100 Link / Activity (RX, TX)	H	Toggle	OFF	Blinking	10 Link / No activity	L	L	ON	ON	10 Link / Activity (RX, TX)	Toggle	Toggle	Blinking	Blinking
Link	Pin State	LED Definition																																																						
Link off	H	OFF																																																						
Link on (any speed)	L	ON																																																						
Link/Activity	Pin State		LED Definition																																																					
	LED2	LED1	LED2	LED1																																																				
Link off	H	H	OFF	OFF																																																				
1000 Link / No activity	L	H	ON	OFF																																																				
1000 Link / Activity (RX, TX)	Toggle	H	Blinking	OFF																																																				
100 Link / No activity	H	L	OFF	ON																																																				
100 Link / Activity (RX, TX)	H	Toggle	OFF	Blinking																																																				
10 Link / No activity	L	L	ON	ON																																																				
10 Link / Activity (RX, TX)	Toggle	Toggle	Blinking	Blinking																																																				
18	DVDDH	P	3.3V, 2.5V, or 1.8V digital V _{DD,IO}																																																					

Pin Number	Pin Name	Type ⁽¹⁾	Pin Function																																																					
19	LED1/ PHYAD0/ PME_N1	I/O	<p>LED1 output: Programmable LED1 output</p> <p>Config mode: The voltage on this pin is sampled and latched during the power-up/reset process to determine the value of PHYAD[0]. See the “Strapping Options” section for details.</p> <p>PME_N output: Programmable PME_N output (pin option 1). This pin function requires an external pull-up resistor to DVDDH (digital V_{DD,I/O}) in a range from 1.0kΩ to 4.7kΩ. When asserted low, this pin signals that a WOL event has occurred.</p> <p>The LED1 pin is programmed by the LED_MODE strapping option (pin 55), and is defined as follows.</p> <p>Single-LED Mode</p> <table border="1"> <thead> <tr> <th>Activity</th> <th>Pin State</th> <th>LED Definition</th> </tr> </thead> <tbody> <tr> <td>No activity</td> <td>H</td> <td>OFF</td> </tr> <tr> <td>Activity (RX, TX)</td> <td>Toggle</td> <td>Blinking</td> </tr> </tbody> </table> <p>Tri-Color Dual-LED Mode</p> <table border="1"> <thead> <tr> <th rowspan="2">Link/Activity</th> <th colspan="2">Pin State</th> <th colspan="2">LED Definition</th> </tr> <tr> <th>LED2</th> <th>LED1</th> <th>LED2</th> <th>LED1</th> </tr> </thead> <tbody> <tr> <td>Link off</td> <td>H</td> <td>H</td> <td>OFF</td> <td>OFF</td> </tr> <tr> <td>1000 Link / No activity</td> <td>L</td> <td>H</td> <td>ON</td> <td>OFF</td> </tr> <tr> <td>1000 Link / Activity (RX, TX)</td> <td>Toggle</td> <td>H</td> <td>Blinking</td> <td>OFF</td> </tr> <tr> <td>100 Link / No activity</td> <td>H</td> <td>L</td> <td>OFF</td> <td>ON</td> </tr> <tr> <td>100 Link / Activity (RX, TX)</td> <td>H</td> <td>Toggle</td> <td>OFF</td> <td>Blinking</td> </tr> <tr> <td>10 Link / No activity</td> <td>L</td> <td>L</td> <td>ON</td> <td>ON</td> </tr> <tr> <td>10 Link / Activity (RX, TX)</td> <td>Toggle</td> <td>Toggle</td> <td>Blinking</td> <td>Blinking</td> </tr> </tbody> </table> <p>For tri-color dual-LED mode, LED1 works in conjunction with LED2 (pin 17) to indicate 10Mbps link and activity.</p>	Activity	Pin State	LED Definition	No activity	H	OFF	Activity (RX, TX)	Toggle	Blinking	Link/Activity	Pin State		LED Definition		LED2	LED1	LED2	LED1	Link off	H	H	OFF	OFF	1000 Link / No activity	L	H	ON	OFF	1000 Link / Activity (RX, TX)	Toggle	H	Blinking	OFF	100 Link / No activity	H	L	OFF	ON	100 Link / Activity (RX, TX)	H	Toggle	OFF	Blinking	10 Link / No activity	L	L	ON	ON	10 Link / Activity (RX, TX)	Toggle	Toggle	Blinking	Blinking
Activity	Pin State	LED Definition																																																						
No activity	H	OFF																																																						
Activity (RX, TX)	Toggle	Blinking																																																						
Link/Activity	Pin State		LED Definition																																																					
	LED2	LED1	LED2	LED1																																																				
Link off	H	H	OFF	OFF																																																				
1000 Link / No activity	L	H	ON	OFF																																																				
1000 Link / Activity (RX, TX)	Toggle	H	Blinking	OFF																																																				
100 Link / No activity	H	L	OFF	ON																																																				
100 Link / Activity (RX, TX)	H	Toggle	OFF	Blinking																																																				
10 Link / No activity	L	L	ON	ON																																																				
10 Link / Activity (RX, TX)	Toggle	Toggle	Blinking	Blinking																																																				
20	DVDDL	P	1.2V digital V _{DD}																																																					
21	TXD0	I	GMII mode: GMII TXD0 (Transmit Data 0) input MII mode: MII TXD0 (Transmit Data 0) input																																																					
22	TXD1	I	GMII mode: GMII TXD1 (Transmit Data 1) input MII mode: MII TXD1 (Transmit Data 1) input																																																					
23	TXD2	I	GMII mode: GMII TXD2 (Transmit Data 2) input MII mode: MII TXD2 (Transmit Data 2) Input																																																					
24	TXD3	I	GMII mode: GMII TXD3 (Transmit Data 3) input MII mode: MII TXD3 (Transmit Data 3) input																																																					
25	DVDDL	P	1.2V digital V _{DD}																																																					
26	TXD4	I	GMII mode: GMII TXD4 (Transmit Data 4) input MII mode: This pin is not used and can be driven high or low.																																																					
27	TXD5	I	GMII mode: GMII TXD5 (Transmit Data 5) input MII mode: This pin is not used and can be driven high or low.																																																					
28	TXD6	I	GMII mode: GMII TXD6 (Transmit Data 6) input MII Mode: This pin is not used and can be driven high or low.																																																					
29	TXD7	I	GMII mode: GMII TXD7 (Transmit Data 7) input MII mode: This pin is not used and can be driven high or low.																																																					

Pin Number	Pin Name	Type ⁽¹⁾	Pin Function
30	DVDDH	P	3.3V, 2.5V, or 1.8V digital V _{DD_IO}
31	TX_ER	I	GMII mode: GMII TX_ER (Transmit Error) input MII mode: MII TX_ER (Transmit Error) input If the GMII/MII MAC does not provide the TX_ER output signal, this pin should be tied low.
32	GTX_CLK	I	GMII mode: GMII GTX_CLK (Transmit Reference Clock) input
33	TX_EN	I	GMII mode: GMII TX_EN (Transmit Enable) input MII mode: MII TX_EN (Transmit Enable) input
34	RXD7	O	GMII mode: GMII RXD7 (Receive Data 7) output MII mode: This pin is not used and is driven low.
35	RXD6	O	GMII mode: GMII RXD6 (Receive Data 6) output MII mode: This pin is not used and is driven low.
36	DVDDL	P	1.2V digital V _{DD}
37	RXD5	O	GMII mode: GMII RXD5 (Receive Data 5) output MII mode: This pin is not used and is driven low.
38	RXD4	O	GMII mode: GMII RXD4 (Receive Data 4) output MII mode: This pin is not used and is driven low.
39	RXD3/ MODE3	I/O	GMII mode: GMII RXD3 (Receive Data 3) output MII mode: MII RXD3 (Receive Data 3) output Config mode: The voltage on this pin is sampled and latched during the power-up/reset process to determine the value of MODE3. See the “ Strapping Options ” section for details.
40	DVDDH	P	3.3V, 2.5V, or 1.8V digital V _{DD_IO}
41	RXD2/ MODE2	I/O	GMII mode: GMII RXD2 (Receive Data 2) output MII mode: MII RXD2 (Receive Data 2) output Config mode: The voltage on this pin is sampled and latched during the power-up/reset process to determine the value of MODE2. See the “ Strapping Options ” section for details.
42	DVDDL	P	1.2V digital V _{DD}
43	RXD1/ MODE1	I/O	GMII mode: GMII RXD1 (Receive Data 1) output MII mode: MII RXD1 (Receive Data 1) output Config mode: The voltage on this pin is sampled and latched during the power-up/reset process to determine the value of MODE1. See the “ Strapping Options ” section for details.
44	RXD0/ MODE0	I/O	GMII mode: GMII RXD0 (Receive Data 0) output MII mode: MII RXD0 (Receive Data 0) output Config mode: The voltage on this pin is sampled and latched during the power-up/reset process to determine the value of MODE0. See the “ Strapping Options ” section for details.
45	RX_DV/ CLK125_EN	I/O	GMII mode: GMII RX_DV (Receive Data Valid) output MII mode: MII RX_DV (Receive Data Valid) output Config mode: The voltage on this pin is sampled and latched during the power-up/reset process to establish the value of CLK125_EN. See the “ Strapping Options ” section for details.
46	DVDDH	P	3.3V, 2.5V, or 1.8V digital V _{DD_IO}
47	RX_ER	O	GMII mode: GMII RX_ER (Receive Error) output MII mode: MII RX_ER (Receive Error) output

Pin Number	Pin Name	Type ⁽¹⁾	Pin Function
48	RX_CLK/ PHYAD2	I/O	GMII mode: GMII RX_CLK (Receive Reference Clock) output MII mode: MII RX_CLK (Receive Reference Clock) output Config mode: The voltage on this pin is sampled and latched during the power-up/reset process to determine the value of PHYAD[2]. See the “ Strapping Options ” section for details.
49	CRS	O	GMII mode: GMII CRS (Carrier Sense) output MII mode: MII CRS (Carrier Sense) output
50	MDC	Ipu	Management data clock input This pin is the input reference clock for MDIO (pin 51).
51	MDIO	Ipu/O	Management data input/output This pin is synchronous to MDC (pin 50) and requires an external pull-up resistor to DVDDH (digital V _{DD}) in a range from 1.0kΩ to 4.7kΩ.
52	COL	O	GMII mode: GMII COL (Collision Detected) output MII mode: MII COL (Collision Detected) output
53	INT_N/ PME_N2	O	Interrupt output: Programmable interrupt output, with register 1Bh as the Interrupt Control/Status register, for programming the interrupt conditions and reading the interrupt status. Register 1Fh, bit [14] sets the interrupt output to active low (default) or active high. PME_N output: Programmable PME_N output (pin option 2). When asserted low, this pin signals that a WOL event has occurred. For Interrupt (when active low) and PME functions, this pin requires an external pull-up resistor to DVDDH (digital V _{DD,I/O}) in a range from 1.0kΩ to 4.7kΩ.
54	DVDDL	P	1.2V digital V _{DD}
55	CLK125_NDO/ LED_MODE	I/O	125MHz clock output This pin provides a 125MHz reference clock output option for use by the MAC. Config mode: The voltage on this pin is sampled during the power-up/reset process to determine the value of LED_MODE. See the “ Strapping Options ” section for details.
56	RESET_N	Ipu	Chip reset (active low) Hardware pin configurations are strapped-in (sampled and latched) at the de-assertion (rising edge) of RESET_N. See the “ Strapping Options ” section for more details.
57	TX_CLK	O	MII mode: MII TX_CLK (Transmit Reference Clock) output
58	LDO_O	O	On-chip 1.2V LDO controller output This pin drives the input gate of a P-channel MOSFET to generate 1.2V for the chip’s core voltages. If the system provides 1.2V and this pin is not used, it can be left floating.
59	AVDDL_PLL	P	1.2V analog V _{DD} for PLL
60	XO	O	25MHz crystal feedback This pin connects to one end of an external 25MHz crystal. This pin is a no connect if an oscillator or other external (non-crystal) clock source is used.
61	XI	I	Crystal / Oscillator/ External Clock input This pin connects to one end of an external 25MHz crystal or to the output of an oscillator or other external (non-crystal) clock source. 25MHz ±50ppm tolerance
62	NC	-	No connect This pin is not bonded and can be connected to AVDDH power for footprint compatibility with the Micrel KSZ9021GN Gigabit PHY.

Pin Number	Pin Name	Type ⁽¹⁾	Pin Function
63	ISET	I/O	Set the transmit output level Connect a 12.1k Ω 1% resistor to ground on this pin.
64	AGNDH	Gnd	Analog ground
PADDLE	P_GND	Gnd	Exposed paddle on bottom of chip Connect P_GND to ground.

Note:

1. P = Power supply.
Gnd = Ground.
I = Input.
O = Output.
I/O = Bi-directional.
Ipu = Input with internal pull-up (see "[Electrical Characteristics](#)" for value).
Ipu/O = Input with internal pull-up (see "[Electrical Characteristics](#)" for value)/Output.

Strapping Options

Pin Number	Pin Name	Type ⁽¹⁾	Pin Function																																		
48 17 19	PHYAD2 PHYAD1 PHYAD0	I/O I/O I/O	The PHY address, PHYAD[2:0], is sampled and latched at power-up/reset and is configurable to any value from 0 to 7. Each PHY address bit is configured as follows: Pull-up = 1 Pull-down = 0 PHY address bits [4:3] are always set to '00'.																																		
39 41 43 44	MODE3 MODE2 MODE1 MODE0	I/O I/O I/O I/O	The MODE[3:0] strap-in pins are sampled and latched at power-up/reset and are defined as follows: <table border="1" data-bbox="592 527 1203 1192"> <thead> <tr> <th>MODE[3:0]</th> <th>Mode</th> </tr> </thead> <tbody> <tr><td>0000</td><td>Reserved – not used</td></tr> <tr><td>0001</td><td>GMI/MII mode</td></tr> <tr><td>0010</td><td>Reserved – not used</td></tr> <tr><td>0011</td><td>Reserved – not used</td></tr> <tr><td>0100</td><td>NAND tree mode</td></tr> <tr><td>0101</td><td>Reserved – not used</td></tr> <tr><td>0110</td><td>Reserved – not used</td></tr> <tr><td>0111</td><td>Chip power-down mode</td></tr> <tr><td>1000</td><td>Reserved – not used</td></tr> <tr><td>1001</td><td>Reserved – not used</td></tr> <tr><td>1010</td><td>Reserved – not used</td></tr> <tr><td>1011</td><td>Reserved – not used</td></tr> <tr><td>1100</td><td>Reserved – not used</td></tr> <tr><td>1101</td><td>Reserved – not used</td></tr> <tr><td>1110</td><td>Reserved – not used</td></tr> <tr><td>1111</td><td>Reserved – not used</td></tr> </tbody> </table>	MODE[3:0]	Mode	0000	Reserved – not used	0001	GMI/MII mode	0010	Reserved – not used	0011	Reserved – not used	0100	NAND tree mode	0101	Reserved – not used	0110	Reserved – not used	0111	Chip power-down mode	1000	Reserved – not used	1001	Reserved – not used	1010	Reserved – not used	1011	Reserved – not used	1100	Reserved – not used	1101	Reserved – not used	1110	Reserved – not used	1111	Reserved – not used
MODE[3:0]	Mode																																				
0000	Reserved – not used																																				
0001	GMI/MII mode																																				
0010	Reserved – not used																																				
0011	Reserved – not used																																				
0100	NAND tree mode																																				
0101	Reserved – not used																																				
0110	Reserved – not used																																				
0111	Chip power-down mode																																				
1000	Reserved – not used																																				
1001	Reserved – not used																																				
1010	Reserved – not used																																				
1011	Reserved – not used																																				
1100	Reserved – not used																																				
1101	Reserved – not used																																				
1110	Reserved – not used																																				
1111	Reserved – not used																																				
45	CLK125_EN	I/O	CLK125_EN is sampled and latched at power-up/reset and is defined as follows: Pull-up (1) = Enable 125MHz clock output Pull-down (0) = Disable 125MHz clock output Pin 55 (CLK125_NDO) provides the 125MHz reference clock output option for use by the MAC.																																		
55	LED_MODE	I/O	LED_MODE is sampled and latched at power-up/reset and is defined as follows: Pull-up (1) = Single-LED mode Pull-down (0) = Tri-color dual-LED mode																																		

Note:

1. I/O = Bi-directional.

Pin strap-ins are latched during power-up or reset. In some systems, the MAC receive input pins may be driven during the power-up or reset process, and consequently cause the PHY strap-in pins on the GMII/MII signals to be latched to the incorrect configuration. In this case, Micrel recommends adding external pull-up or pull-down resistors on the PHY strap-in pins to ensure the PHY is configured to the correct pin strap-in mode.

Functional Overview

The KSZ9031MNX is a completely integrated triple-speed (10Base-T/100Base-TX/1000Base-T) Ethernet physical layer transceiver solution for transmission and reception of data over a standard CAT-5 unshielded twisted pair (UTP) cable. Its on-chip proprietary 1000Base-T transceiver and Manchester/MLT-3 signaling-based 10Base-T/100Base-TX transceivers are all IEEE 802.3 compliant.

The KSZ9031MNX reduces board cost and simplifies board layout by using on-chip termination resistors for the four differential pairs and by integrating an LDO controller to drive a low-cost MOSFET to supply the 1.2V core.

On the copper media interface, the KSZ9031MNX can automatically detect and correct for differential pair misplacements and polarity reversals, and correct propagation delays and re-sync timing between the four differential pairs, as specified in the IEEE 802.3 standard for 1000Base-T operation.

The KSZ9031MNX provides the GMII/MII interface for connection to GMACs in Gigabit Ethernet processors and switches for data transfer at 10/100/1000Mbps.

Figure 1 shows a high-level block diagram of the KSZ9031MNX.

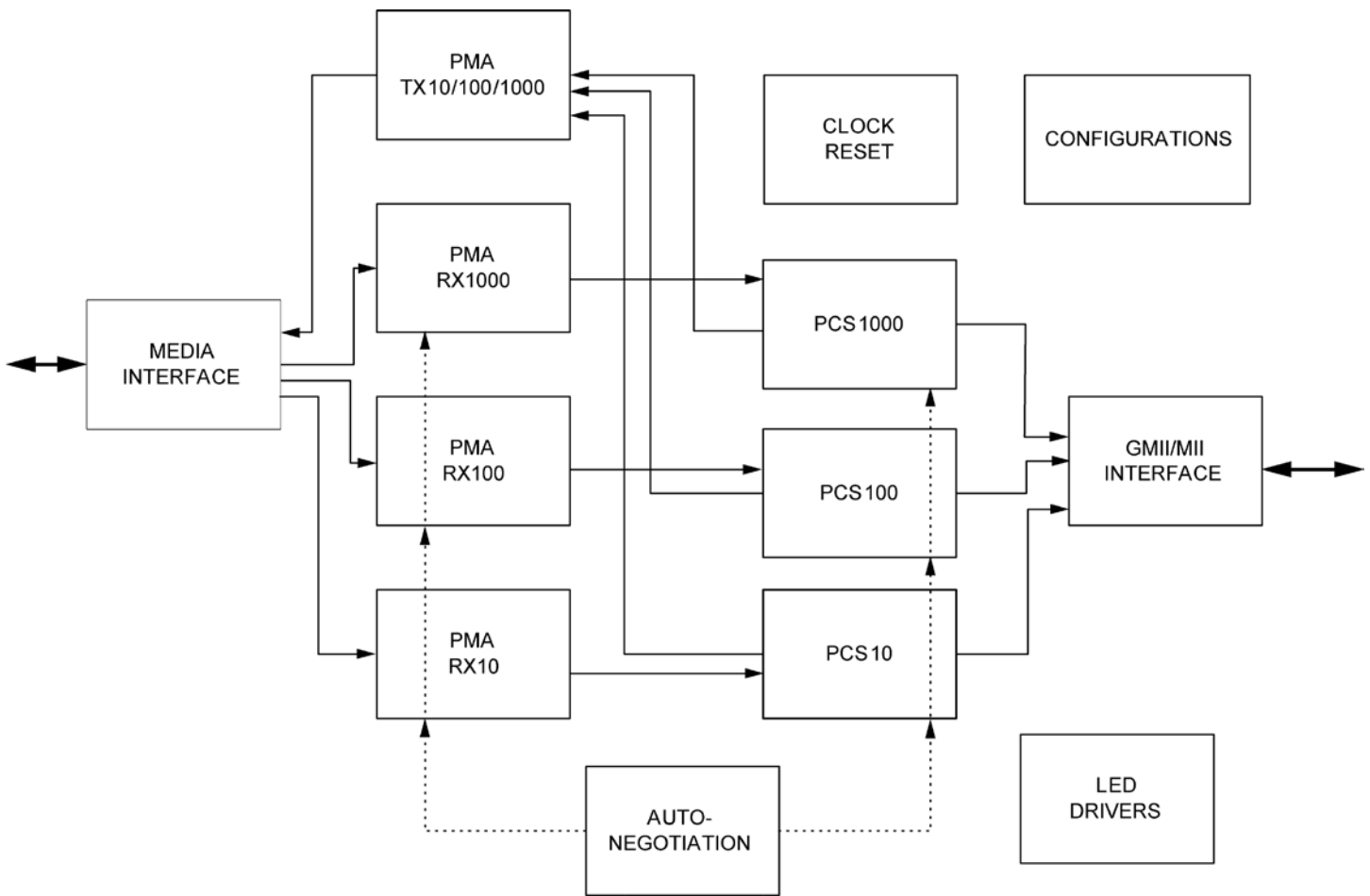

Figure 1. KSZ9031MNX Block Diagram

Functional Description: 10Base-T/100Base-TX Transceiver

100Base-TX Transmit

The 100Base-TX transmit function performs parallel-to-serial conversion, 4B/5B coding, scrambling, NRZ-to-NRZI conversion, and MLT-3 encoding and transmission.

The circuitry starts with a parallel-to-serial conversion, which converts the MII data from the MAC into a 125MHz serial bit stream. The data and control stream is then converted into 4B/5B coding, followed by a scrambler. The serialized data is further converted from NRZ-to-NRZI format, then transmitted in MLT-3 current output. The output current is set by an external 12.1k Ω 1% resistor for the 1:1 transformer ratio.

The output signal has a typical rise/fall time of 4ns and complies with the ANSI TP-PMD standard regarding amplitude balance, overshoot, and timing jitter. The wave-shaped 10Base-T output is also incorporated into the 100Base-TX transmitter.

100Base-TX Receive

The 100BASE-TX receiver function performs adaptive equalization, DC restoration, MLT-3-to-NRZI conversion, data and clock recovery, NRZI-to-NRZ conversion, de-scrambling, 4B/5B decoding, and serial-to-parallel conversion.

The receiving side starts with the equalization filter to compensate for inter-symbol interference (ISI) over the twisted pair cable. Because the amplitude loss and phase distortion are a function of the cable length, the equalizer must adjust its characteristics to optimize performance. In this design, the variable equalizer makes an initial estimation based on comparisons of incoming signal strength against some known cable characteristics, then tunes itself for optimization. This is an ongoing process and self-adjusts against environmental changes such as temperature variations.

Next, the equalized signal goes through a DC-restoration and data-conversion block. The DC-restoration circuit compensates for the effect of baseline wander and improves the dynamic range. The differential data conversion circuit converts the MLT-3 format back to NRZI. The slicing threshold is also adaptive.

The clock-recovery circuit extracts the 125MHz clock from the edges of the NRZI signal. This recovered clock is then used to convert the NRZI signal into the NRZ format. This signal is sent through the de-scrambler followed by the 4B/5B decoder. Finally, the NRZ serial data is converted to the GMII/MII format and provided as the input data to the MAC.

Scrambler/De-Scrambler (100Base-TX only)

The purpose of the scrambler is to spread the power spectrum of the signal to reduce electromagnetic interference (EMI) and baseline wander. Transmitted data is scrambled using an 11-bit wide linear feedback shift register (LFSR). The scrambler generates a 2047-bit non-repetitive sequence, then the receiver de-scrambles the incoming data stream using the same sequence as at the transmitter.

10Base-T Transmit

The 10Base-T output drivers are incorporated into the 100Base-TX drivers to allow for transmission with the same magnetic. The drivers perform internal wave-shaping and pre-emphasis, and output signals with a typical amplitude of 2.5V peak for standard 10Base-T mode and 1.75V peak for energy-efficient 10Base-Te mode. The 10Base-T/10Base-Te signals have harmonic contents that are at least 31dB below the fundamental frequency when driven by an all-ones Manchester-encoded signal.

10Base-T Receive

On the receive side, input buffer and level-detecting squelch circuits are used. A differential input receiver circuit and a phase-locked loop (PLL) perform the decoding function. The Manchester-encoded data stream is separated into clock signal and NRZ data. A squelch circuit rejects signals with levels less than 300mV or with short pulse widths to prevent noises at the receive inputs from falsely triggering the decoder. When the input exceeds the squelch limit, the PLL locks onto the incoming signal and the KSZ9031MNX decodes a data frame. The receiver clock is maintained active during idle periods between receiving data frames.

Auto-polarity correction is provided for the receive differential pair to automatically swap and fix the incorrect +/- polarity wiring in the cabling.

Functional Description: 1000Base-T Transceiver

The 1000Base-T transceiver is based-on a mixed-signal/digital-signal processing (DSP) architecture, which includes the analog front-end, digital channel equalizers, trellis encoders/decoders, echo cancellers, cross-talk cancellers, precision clock recovery scheme, and power-efficient line drivers.

Figure 2 shows a high-level block diagram of a single channel of the 1000Base-T transceiver for one of the four differential pairs.

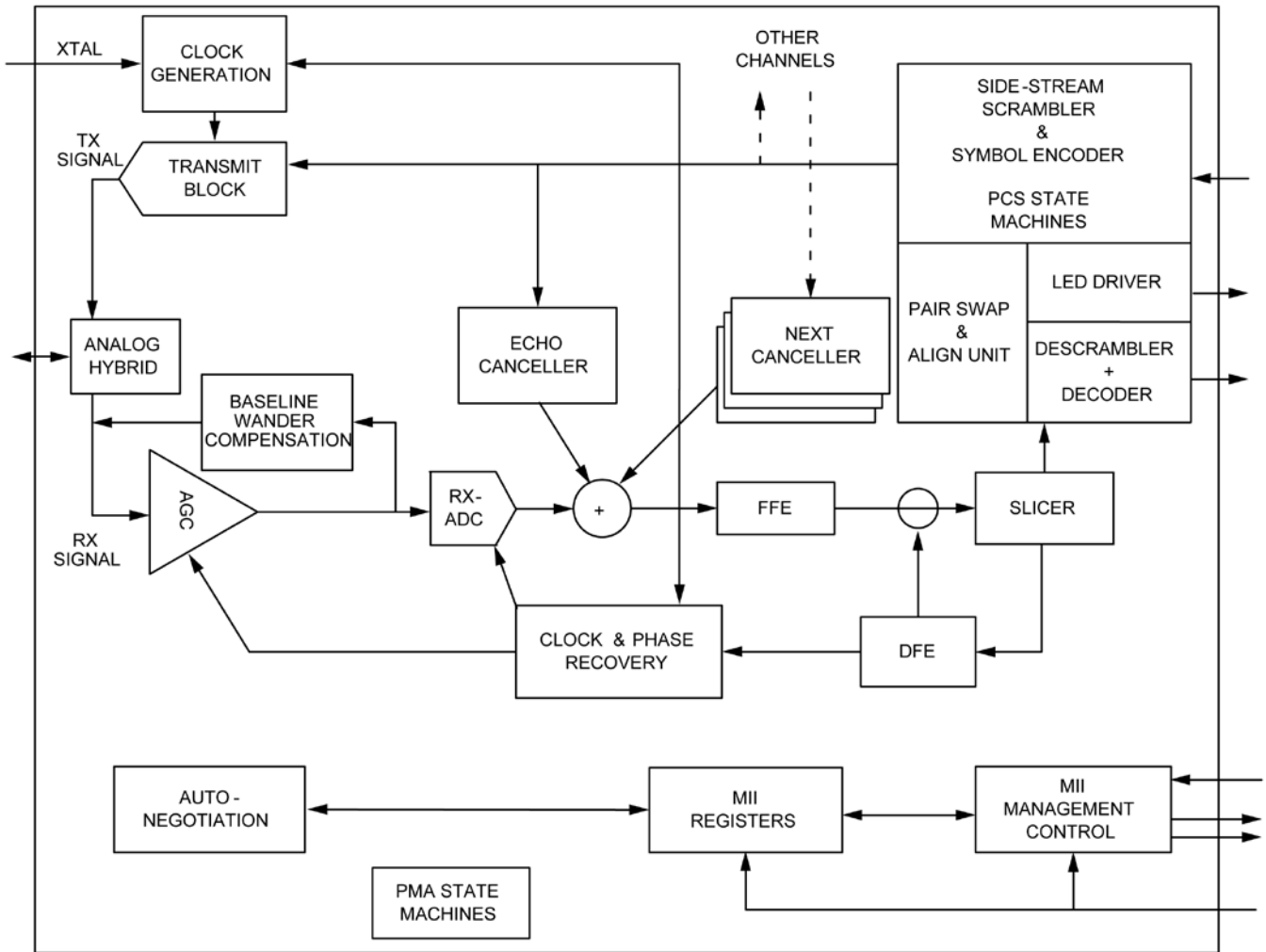

Figure 2. KSZ9031MNX 1000Base-T Block Diagram – Single Channel

Analog Echo-Cancellation Circuit

In 1000Base-T mode, the analog echo-cancellation circuit helps to reduce the near-end echo. This analog hybrid circuit relieves the burden of the ADC and the adaptive equalizer.

This circuit is disabled in 10Base-T/100Base-TX mode.

Automatic Gain Control (AGC)

In 1000Base-T mode, the automatic gain control (AGC) circuit provides initial gain adjustment to boost up the signal level. This pre-conditioning circuit is used to improve the signal-to-noise ratio of the receive signal.

Analog-to-Digital Converter (ADC)

In 1000Base-T mode, the analog-to-digital converter (ADC) digitizes the incoming signal. ADC performance is essential to the overall performance of the transceiver.

This circuit is disabled in 10Base-T/100Base-TX mode.

Timing Recovery Circuit

In 1000Base-T mode, the mixed-signal clock recovery circuit together with the digital phase-locked loop is used to recover and track the incoming timing information from the received data. The digital phase-locked loop has very low long-term jitter to maximize the signal-to-noise ratio of the receive signal.

The 1000Base-T slave PHY must transmit the exact receive clock frequency recovered from the received data back to the 1000Base-T master PHY. Otherwise, the master and slave will not be synchronized after long transmission. This also helps to facilitate echo cancellation and NEXT removal.

Adaptive Equalizer

In 1000Base-T mode, the adaptive equalizer provides the following functions:

- Detection for partial response signaling
- Removal of NEXT and ECHO noise
- Channel equalization

Signal quality is degraded by residual echo that is not removed by the analog hybrid because of impedance mismatch. The KSZ9031MNX uses a digital echo canceller to further reduce echo components on the receive signal.

In 1000Base-T mode, data transmission and reception occurs simultaneously on all four pairs of wires (four channels). This results in high-frequency cross-talk coming from adjacent wires. The KSZ9031MNX uses three NEXT cancellers on each receive channel to minimize the cross-talk induced by the other three channels.

In 10Base-T/100Base-TX mode, the adaptive equalizer needs only to remove the inter-symbol interference and recover the channel loss from the incoming data.

Trellis Encoder and Decoder

In 1000Base-T mode, the transmitted 8-bit data is scrambled into 9-bit symbols and further encoded into 4D-PAM5 symbols. The initial scrambler seed is determined by the specific PHY address to reduce EMI when more than one KSZ9031MNX is used on the same board. On the receiving side, the idle stream is examined first. The scrambler seed, pair skew, pair order, and polarity must be resolved through the logic. The incoming 4D-PAM5 data is then converted into 9-bit symbols and de-scrambled into 8-bit data.

Functional Description: Additional 10/100/1000 PHY Features

The Automatic MDI/MDI-X feature eliminates the need to determine whether to use a straight cable or a crossover cable between the KSZ9031MNX and its link partner. This auto-sense function detects the MDI/MDI-X pair mapping from the link partner, and assigns the MDI/MDI-X pair mapping of the KSZ9031MNX accordingly.

Table 1 shows the KSZ9031MNX 10/100/1000 pin configuration assignments for MDI/MDI-X pin mapping.

Pin (RJ-45 pair)	MDI			MDI-X		
	1000Base-T	100Base-TX	10Base-T	1000Base-T	100Base-TX	10Base-T
TXRXP/M_A (1,2)	A+/-	TX+/-	TX+/-	B+/-	RX+/-	RX+/-
TXRXP/M_B (3,6)	B+/-	RX+/-	RX+/-	A+/-	TX+/-	TX+/-
TXRXP/M_C (4,5)	C+/-	Not used	Not used	D+/-	Not used	Not used
TXRXP/M_D (7,8)	D+/-	Not used	Not used	C+/-	Not used	Not used

Table 1. MDI/MDI-X Pin Mapping

Auto MDI/MDI-X is enabled by default. It is disabled by writing a one to register 1Ch, bit [6]. MDI and MDI-X mode is set by register 1Ch, bit [7] if Auto MDI/MDI-X is disabled.

An isolation transformer with symmetrical transmit and receive data paths is recommended to support Auto MDI/MDI-X.

Pair-Swap, Alignment, and Polarity Check

In 1000Base-T mode, the KSZ9031MNX

- Detects incorrect channel order and automatically restores the pair order for the A, B, C, D pairs (four channels)
- Supports 50 ± 10 ns difference in propagation delay between pairs of channels in accordance with the IEEE 802.3 standard, and automatically corrects the data skew so the corrected four pairs of data symbols are synchronized

Incorrect pair polarities of the differential signals are automatically corrected for all speeds.

Wave Shaping, Slew-Rate Control, and Partial Response

In communication systems, signal transmission encoding methods are used to provide the noise-shaping feature and to minimize distortion and error in the transmission channel.

- For 1000Base-T, a special partial-response signaling method is used to provide the band-limiting feature for the transmission path.
- For 100Base-TX, a simple slew-rate control method is used to minimize EMI.
- For 10Base-T, pre-emphasis is used to extend the signal quality through the cable.

PLL Clock Synthesizer

The KSZ9031MNX generates 125MHz, 25MHz, and 10MHz clocks for system timing. Internal clocks are generated from the external 25MHz crystal or reference clock.

Auto-Negotiation

The KSZ9031MNX conforms to the auto-negotiation protocol, defined in Clause 28 of the IEEE 802.3 Specification.

Auto-negotiation allows UTP (unshielded twisted pair) link partners to select the highest common mode of operation.

During auto-negotiation, link partners advertise capabilities across the UTP link to each other, and then compare their own capabilities with those they received from their link partners. The highest speed and duplex setting that is common to the two link partners is selected as the operating mode.

The following list shows the speed and duplex operation mode from highest to lowest.

- Priority 1: 1000Base-T, full-duplex
- Priority 2: 1000Base-T, half-duplex
- Priority 3: 100Base-TX, full-duplex
- Priority 4: 100Base-TX, half-duplex
- Priority 5: 10Base-T, full-duplex
- Priority 6: 10Base-T, half-duplex

If auto-negotiation is not supported or the KSZ9031MNX link partner is forced to bypass auto-negotiation for 10Base-T and 100Base-TX modes, the KSZ9031MNX sets its operating mode by observing the input signal at its receiver. This is known as parallel detection, and allows the KSZ9031MNX to establish a link by listening for a fixed signal protocol in the absence of the auto-negotiation advertisement protocol.

The auto-negotiation link-up process is shown in [Figure 3](#).

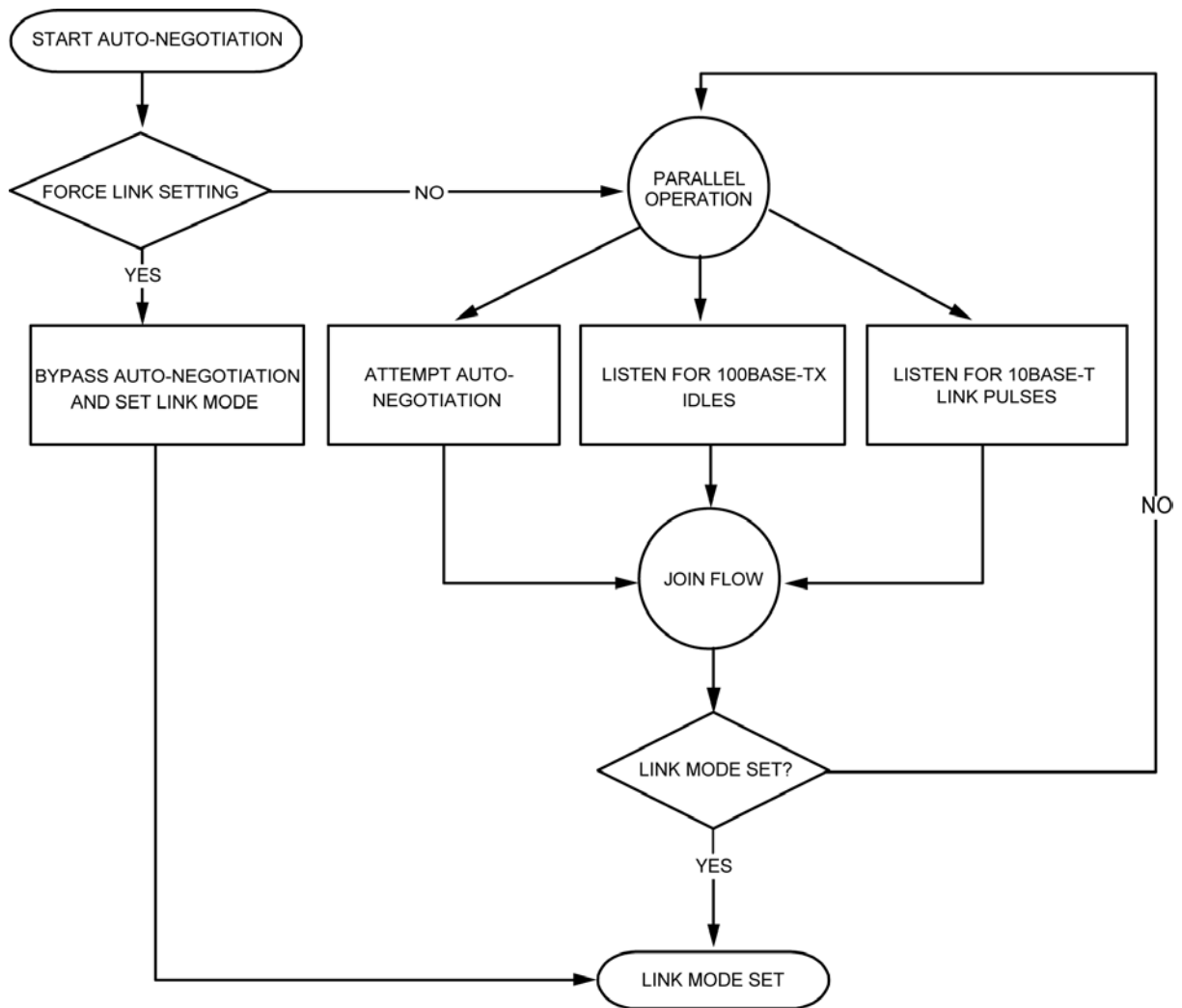

Figure 3. Auto-Negotiation Flow Chart

For 1000Base-T mode, auto-negotiation is required and always used to establish a link. During 1000Base-T auto-negotiation, the master and slave configuration is first resolved between link partners. Then the link is established with the highest common capabilities between link partners.

Auto-negotiation is enabled by default after power-up or hardware reset. After that, auto-negotiation can be enabled or disabled through register 0h, bit [12]. If auto-negotiation is disabled, the speed is set by register 0h, bits [6, 13] and the duplex is set by register 0h, bit [8].

If the speed is changed on the fly, the link goes down and either auto-negotiation or parallel detection initiates until a common speed between KSZ9031MNX and its link partner is re-established for a link.

If the link is already established and there is no change of speed on the fly, the changes (for example, duplex and pause capabilities) will not take effect unless either auto-negotiation is restarted through register 0h, bit [9], or a link-down to link-up transition occurs (that is, disconnecting and reconnecting the cable).

After auto-negotiation is completed, the link status is updated in register 1h, bit [2], and the link partner capabilities are updated in registers 5h, 6h, and Ah.

The auto-negotiation finite state machines use interval timers to manage the auto-negotiation process. The duration of these timers under normal operating conditions is summarized in [Table 2](#).

Auto-Negotiation Interval Timers	Time Duration
Transmit burst interval	16 ms
Transmit pulse interval	68 μ s
FLP detect minimum time	17.2 μ s
FLP detect maximum time	185 μ s
Receive minimum burst interval	6.8 ms
Receive maximum burst interval	112 ms
Data detect minimum interval	35.4 μ s
Data detect maximum interval	95 μ s
NLP test minimum interval	4.5 ms
NLP test maximum interval	30 ms
Link loss time	52 ms
Break link time	1480 ms
Parallel detection wait time	830 ms
Link enable wait time	1000 ms

Table 2. Auto-Negotiation Timers

GMII Interface

The Gigabit Media Independent Interface (GMII) is compliant to the IEEE 802.3 Specification. It provides a common interface between GMII PHYs and MACs, and has the following key characteristics:

- Pin count is 24 pins (11 pins for data transmission, 11 pins for data reception, and 2 pins for carrier and collision indication).
- 1000Mbps is supported at both half and full duplex.
- Data transmission and reception are independent and belong to separate signal groups.
- Transmit data and receive data are each 8 bits wide, a byte.

In GMII operation, the GMII pins function as follows:

- The MAC sources the transmit reference clock, GTX_CLK, at 125MHz for 1000Mbps.
- The PHY recovers and sources the receive reference clock, RX_CLK, at 125MHz for 1000Mbps.
- TX_EN, TXD[7:0], and TX_ER are sampled by the KSZ9031MNX on the rising edge of GTX_CLK.
- RX_DV, RXD[7:0], and RX_ER are sampled by the MAC on the rising edge of RX_CLK.
- CRS and COL are driven by the KSZ9031MNX and do not have to transition synchronously with respect to either GTX_CLK or RX_CLK.

The KSZ9031MNX combines GMII mode with MII mode to form GMII/MII mode to support data transfer at 10/100/1000Mbps. After power-up or reset, the KSZ9031MNX is configured to GMII/MII mode if the MODE[3:0] strap-in pins are set to '0001'. See the "[Strapping Options](#)" section.

The KSZ9031MNX has the option to output a 125MHz reference clock on CLK125_NDO (pin 55). This clock provides a lower-cost reference clock alternative for GMII/MII MACs that require a 125MHz crystal or oscillator. The 125MHz clock output is enabled after power-up or reset if the CLK125_EN strap-in pin is pulled high.

The KSZ9031MNX provides a dedicated transmit clock input pin for GMII mode, defined as follows:

- GTX_CLK (input, pin 32): Sourced by MAC in GMII mode for 1000Mbps speed

GMII Signal Definition

Table 3 describes the GMII signals. Refer to Clause 35 of the IEEE 802.3 Specification for more detailed information.

GMII Signal Name (per spec)	GMII Signal Name (per KSZ9031MNX)	Pin Type (with respect to PHY)	Pin Type (with respect to MAC)	Description
GTX_CLK	GTX_CLK	Input	Output	Transmit Reference Clock (125MHz for 1000Mbps)
TX_EN	TX_EN	Input	Output	Transmit Enable
TXD[7:0]	TXD[7:0]	Input	Output	Transmit Data[7:0]
TX_ER	TX_ER	Input	Output	Transmit Error
RX_CLK	RX_CLK	Output	Input	Receive Reference Clock (125MHz for 1000Mbps)
RX_DV	RX_DV	Output	Input	Receive Data Valid
RXD[7:0]	RXD[7:0]	Output	Input	Receive Data[7:0]
RX_ER	RX_ER	Output	Input	Receive Error
CRS	CRS	Output	Input	Carrier Sense
COL	COL	Output	Input	Collision Detected

Table 3. GMII Signal Definition

GMII Signal Diagram

The KSZ9031MNX GMII pin connections to the MAC are shown in Figure 4.

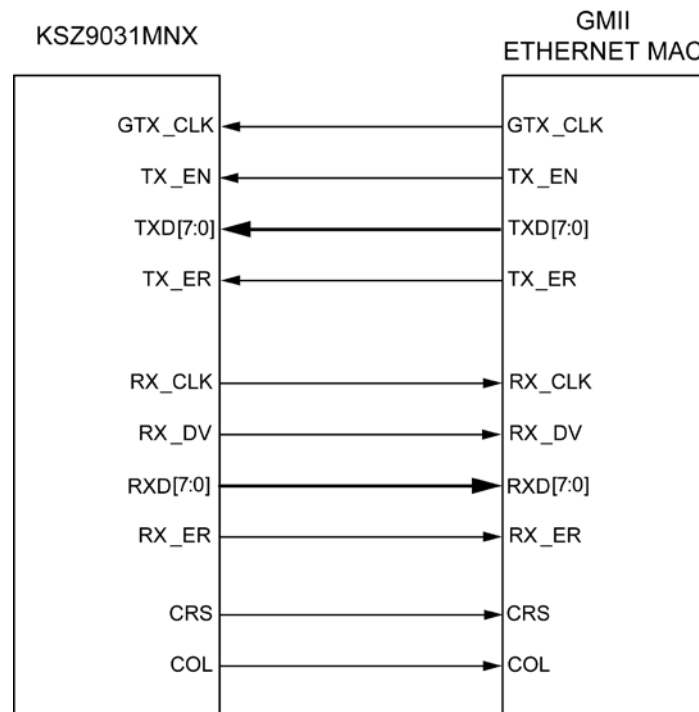

Figure 4. KSZ9031MNX GMII Interface

MII Interface

The Media Independent Interface (MII) is compliant with the IEEE 802.3 Specification. It provides a common interface between MII PHYs and MACs, and has the following key characteristics:

- Pin count is 16 pins (7 pins for data transmission, 7 pins for data reception, and 2 pins for carrier and collision indication).
- 10Mbps and 100Mbps are supported at both half- and full-duplex.
- Data transmission and reception are independent and belong to separate signal groups.
- Transmit data and receive data are each 4 bits wide, a nibble.

In MII operation, the MII pins function as follows:

- The PHY sources the transmit reference clock, TX_CLK, at 25MHz for 100Mbps and 2.5MHz for 10Mbps.
- The PHY recovers and sources the receive reference clock, RX_CLK, at 25MHz for 100Mbps and 2.5MHz for 10Mbps.
- TX_EN, TXD[3:0], and TX_ER are driven by the MAC and transition synchronously with respect to TX_CLK.
- RX_DV, RXD[3:0], and RX_ER are driven by the KSZ9031MNX and transition synchronously with respect to RX_CLK.
- CRS and COL are driven by the KSZ9031MNX and do not have to transition synchronously with respect to either TX_CLK or RX_CLK.

The KSZ9031MNX combines GMII mode with MII mode to form GMII/MII mode to support data transfer at 10/100/1000Mbps. After the power-up or reset, the KSZ9031MNX is then configured to GMII/MII mode if the MODE[3:0] strap-in pins are set to '0001'. See the "[Strapping Options](#)" section.

The KSZ9031MNX has the option to output a 125MHz reference clock on CLK125_NDO (pin 55). This clock provides a lower-cost reference clock alternative for GMII/MII MACs that require a 125MHz crystal or oscillator. The 125MHz clock output is enabled after power-up or reset if the CLK125_EN strap-in pin is pulled high.

The KSZ9031MNX provides a dedicated transmit clock output pin for MII mode, defined as follows:

- TX_CLK (output, pin 57): Sourced by KSZ9031MNX in MII mode for 10/100Mbps speed

MII Signal Definition

Table 4 describes the MII signals. Refer to Clause 22 of the IEEE 802.3 Specification for detailed information.

MII Signal Name (per spec)	MII Signal Name (per KSZ9031MNX)	Pin Type (with respect to PHY)	Pin Type (with respect to MAC)	Description
TX_CLK	TX_CLK	Output	Input	Transmit Reference Clock (25MHz for 100Mbps, 2.5MHz for 10Mbps)
TX_EN	TX_EN	Input	Output	Transmit Enable
TXD[3:0]	TXD[3:0]	Input	Output	Transmit Data[3:0]
TX_ER	TX_ER	Input	Output	Transmit Error
RX_CLK	RX_CLK	Output	Input	Receive Reference Clock (25MHz for 100Mbps, 2.5MHz for 10Mbps)
RX_DV	RX_DV	Output	Input	Receive Data Valid
RXD[3:0]	RXD[3:0]	Output	Input	Receive Data[3:0]
RX_ER	RX_ER	Output	Input	Receive Error
CRS	CRS	Output	Input	Carrier Sense
COL	COL	Output	Input	Collision Detected

Table 4. MII Signal Definition

MII Signal Diagram

The KSZ9031MNX MII pin connections to the MAC are shown in Figure 5.

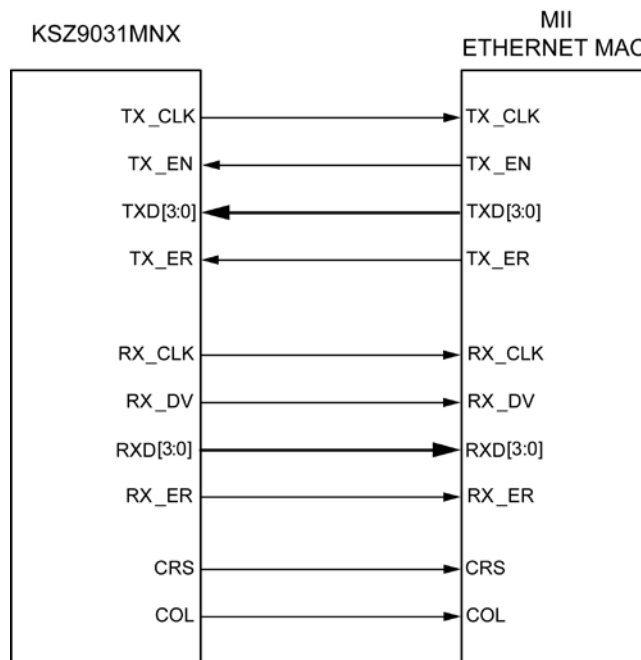

Figure 5. KSZ9031MNX MII Interface

MII Management (MIIM) Interface

The KSZ9031MNX supports the IEEE 802.3 MII management interface, also known as the Management Data Input/Output (MDIO) interface. This interface allows upper-layer devices to monitor and control the state of the KSZ9031MNX. An external device with MIIM capability is used to read the PHY status and/or configure the PHY settings. More details about the MIIM interface can be found in Clause 22.2.4 of the IEEE 802.3 Specification.

The MIIM interface consists of the following:

- A physical connection that incorporates the clock line (MDC) and the data line (MDIO).
- A specific protocol that operates across the physical connection mentioned earlier, which allows an external controller to communicate with one or more KSZ9031MNX devices. Each KSZ9031MNX device is assigned a unique PHY address between 0h and 7h by the PHYAD[2:0] strapping pins.
- A 32-register address space for direct access to IEEE-defined registers and vendor-specific registers, and for indirect access to MMD addresses and registers. See the “[Register Map](#)” section.

PHY address 0h is supported as the unique PHY address only; it is not supported as the broadcast PHY address, which allows for a single write command to simultaneously program an identical PHY register for two or more PHY devices (for example, using PHY address 0h to set register 0h to a value of 0x1940 to set bit [11] to a value of one to enable software power-down). Instead, separate write commands are used to program each PHY device.

[Table 5](#) shows the MII management frame format for the KSZ9031MNX.

	Preamble	Start of Frame	Read/Write OP Code	PHY Address Bits [4:0]	REG Address Bits [4:0]	TA	Data Bits [15:0]	Idle
Read	32 1's	01	10	00AAA	RRRRR	Z0	DDDDDDDD_DDDDDDDD	Z
Write	32 1's	01	01	00AAA	RRRRR	10	DDDDDDDD_DDDDDDDD	Z

Table 5. MII Management Frame Format for the KSZ9031MNX

Interrupt (INT_N)

The INT_N pin is an optional interrupt signal that is used to inform the external controller that there has been a status update in the KSZ9031MNX PHY register. Bits [15:8] of register 1Bh are the interrupt control bits that enable and disable the conditions for asserting the INT_N signal. Bits [7:0] of register 1Bh are the interrupt status bits that indicate which interrupt conditions have occurred. The interrupt status bits are cleared after reading register 1Bh.

Bit [14] of register 1Fh sets the interrupt level to active high or active low. The default is active low.

The MII management bus option gives the MAC processor complete access to the KSZ9031MNX control and status registers. Additionally, an interrupt pin eliminates the need for the processor to poll the PHY for status change.

LED Mode

The KSZ9031MNX provides two programmable LED output pins, LED2 and LED1, which are configurable to support two LED modes. The LED mode is configured by the LED_MODE strap-in (pin 55). It is latched at power-up/reset and is defined as follows:

- Pull-up: Single-LED mode
- Pull-down: Tri-color dual-LED mode

Single-LED Mode

In single-LED mode, the LED2 pin indicates the link status while the LED1 pin indicates the activity status, as shown in [Table 6](#).

LED Pin	Pin State	LED Definition	Link/Activity
LED2	H	OFF	Link off
	L	ON	Link on (any speed)
LED1	H	OFF	No activity
	Toggle	Blinking	Activity (RX, TX)

Table 6. Single-LED Mode – Pin Definition

Tri-color Dual-LED Mode

In tri-color dual-LED mode, the link and activity status are indicated by the LED2 pin for 1000Base-T; by the LED1 pin for 100Base-TX; and by both LED2 and LED1 pins, working in conjunction, for 10Base-T. This is summarized in [Table 7](#).

LED Pin (State)		LED Pin (Definition)		Link/Activity
LED2	LED1	LED2	LED1	
H	H	OFF	OFF	Link off
L	H	ON	OFF	1000 Link / No activity
Toggle	H	Blinking	OFF	1000 Link / Activity (RX, TX)
H	L	OFF	ON	100 Link / No activity
H	Toggle	OFF	Blinking	100 Link / Activity (RX, TX)
L	L	ON	ON	10 Link / No activity
Toggle	Toggle	Blinking	Blinking	10 Link / Activity (RX, TX)

Table 7. Tri-color Dual-LED Mode – Pin Definition

Each LED output pin can directly drive an LED with a series resistor (typically 220Ω to 470Ω).

Loopback Mode

The KSZ9031MNX supports the following loopback operations to verify analog and/or digital data paths.

- Local (digital) loopback
- Remote (analog) loopback

Local (Digital) Loopback

This loopback mode checks the GMII/MII transmit and receive data paths between KSZ9031MNX and external MAC, and is supported for all three speeds (10/100/1000Mbps) at full-duplex.

The loopback data path is shown in [Figure 6](#).

1. GMII/MII MAC transmits frames to KSZ9031MNX.
2. Frames are wrapped around inside KSZ9031MNX.
3. KSZ9031MNX transmits frames back to GMII/MII MAC.

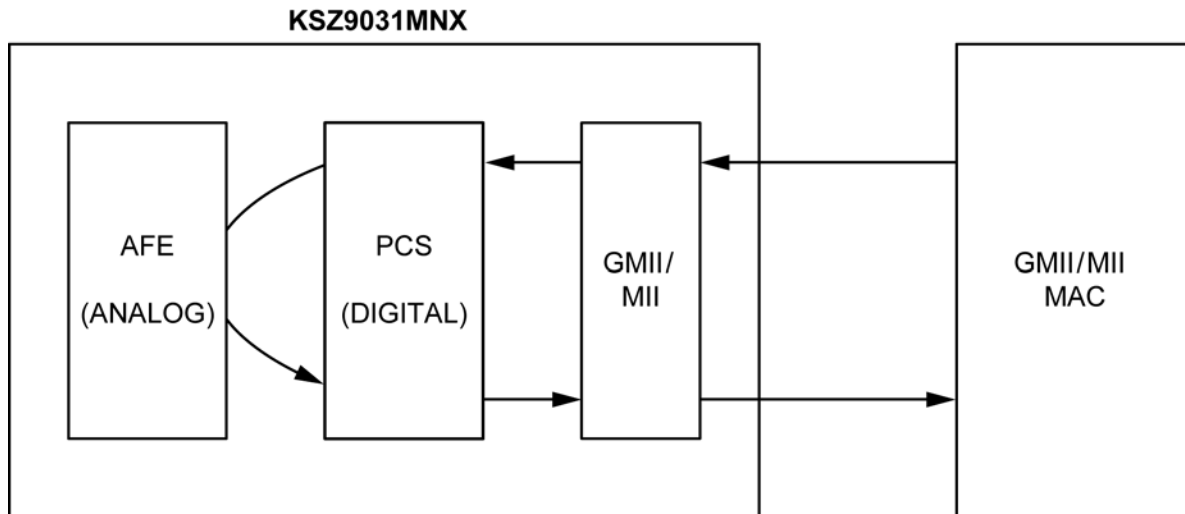

Figure 6. Local (Digital) Loopback

The following programming steps and register settings are used for local loopback mode.

For 1000Mbps loopback,

1. Set register 0h,
 - Bit [14] = 1 // Enable local loopback mode
 - Bits [6, 13] = 10 // Select 1000Mbps speed
 - Bit [12] = 0 // Disable auto-negotiation
 - Bit [8] = 1 // Select full-duplex mode
2. Set register 9h,
 - Bit [12] = 1 // Enable master-slave manual configuration
 - Bit [11] = 0 // Select slave configuration (required for loopback mode)

For 10/100Mbps loopback,

1. Set register 0h,
 - Bit [14] = 1 // Enable local loopback mode
 - Bits [6, 13] = 00 / 01 // Select 10Mbps/100Mbps speed
 - Bit [12] = 0 // Disable auto-negotiation
 - Bit [8] = 1 // Select full-duplex mode

Remote (Analog) Loopback

This loopback mode checks the line (differential pairs, transformer, RJ-45 connector, Ethernet cable) transmit and receive data paths between KSZ9031MNX and its link partner, and is supported for 1000Base-T full-duplex mode only.

The loopback data path is shown in [Figure 7](#).

1. The Gigabit PHY link partner transmits frames to KSZ9031MNX.
2. Frames are wrapped around inside KSZ9031MNX.
3. KSZ9031MNX transmits frames back to the Gigabit PHY link partner.

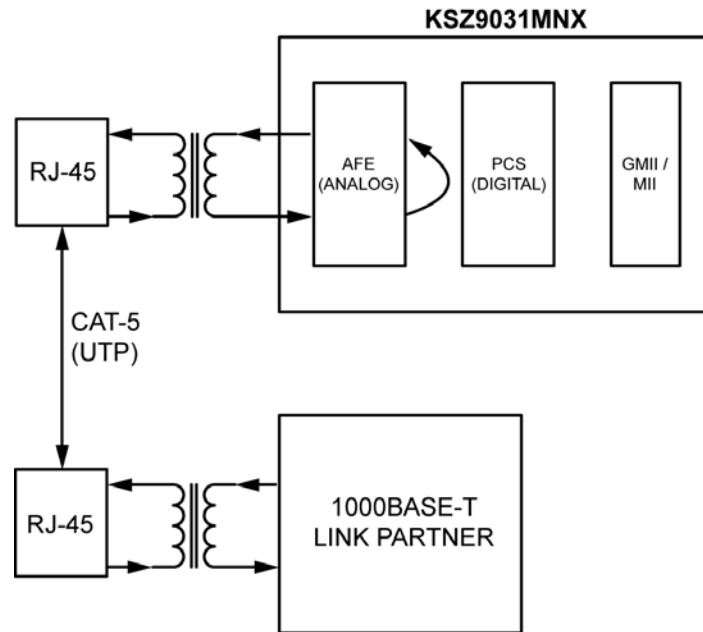

Figure 7. Remote (Analog) Loopback

The following programming steps and register settings are used for remote loopback mode.

1. Set Register 0h,
 - Bits [6, 13] = 10 // Select 1000Mbps speed
 - Bit [12] = 0 // Disable auto-negotiation
 - Bit [8] = 1 // Select full-duplex mode
 Or just auto-negotiate and link up at 100Base-TX full-duplex mode with the link partner.
2. Set Register 11h,
 - Bit [8] = 1 // Enable remote loopback mode

LinkMD[®] Cable Diagnostic

The LinkMD function uses time domain reflectometry (TDR) to analyze the cabling plant for common cabling problems, such as open circuits, short circuits, and impedance mismatches.

LinkMD operates by sending a pulse of known amplitude and duration down the selected differential pair, then analyzing the polarity and shape of the reflected signal to determine the type of fault: open circuit for a positive/non-inverted amplitude reflection and short circuit for a negative/inverted amplitude reflection. The time duration for the reflected signal to return provides the approximate distance to the cabling fault. The LinkMD function processes this TDR information and presents it as a numerical value that can be translated to a cable distance.

LinkMD is initiated by accessing register 12h, the LinkMD – Cable Diagnostic register, in conjunction with register 1Ch, the Auto MDI/MDI-X register. The latter register is needed to disable the Auto MDI/MDI-X function before running the LinkMD test. Additionally, a software reset (Reg. 0h, bit [15] = 1) should be performed before and after running the LinkMD test. The reset helps to ensure the KSZ9031MNX is in the normal operating state before and after the test.

NAND Tree Support

The KSZ9031MNX provides parametric NAND tree support for fault detection between chip I/Os and board. NAND tree mode is enabled at power-up/reset with the MODE[3:0] strap-in pins set to '0100'.

[Table 8](#) lists the NAND tree pin order.

Pin	Description
LED2	Input
LED1/PME_N1	Input
TXD0	Input
TXD1	Input
TXD2	Input
TXD3	Input
TX_ER	Input
GTX_CLK	Input
TX_EN	Input
RX_DV	Input
RX_ER	Input
RX_CLK	Input
CRS	Input
COL	Input
INT_N/PME_N2	Input
MDC	Input
MDIO	Input
CLK125_NDO	Output

Table 8. NAND Tree Test Pin Order for KSZ9031MNX

Power Management

The KSZ9031MNX incorporates a number of power-management modes and features that provide methods to consume less energy. These are discussed in the following sections.

Energy-Detect Power-Down Mode

Energy-detect power-down (EDPD) mode is used to further reduce the transceiver power consumption when the cable is unplugged. It is enabled by writing a one to MMD address 1Ch, register 23h, bit [0], and is in effect when auto-negotiation mode is enabled and the cable is disconnected (no link).

In EDPD Mode, the KSZ9031MNX shuts down all transceiver blocks, except for the transmitter and energy detect circuits. Power can be reduced further by extending the time interval between the transmissions of link pulses to check for the presence of a link partner. The periodic transmission of link pulses is needed to ensure the KSZ9031MNX and its link partner, when operating in the same low-power state and with Auto MDI/MDI-X disabled, can wake up when the cable is connected between them. By default, EDPD mode is disabled after power-up.

Software Power-Down Mode

This mode is used to power down the KSZ9031MNX device when it is not in use after power-up. Software power-down (SPD) mode is enabled by writing a one to register 0h, bit [11]. In the SPD state, the KSZ9031MNX disables all internal functions, except for the MII management interface. The KSZ9031MNX exits the SPD state after a zero is written to register 0h, bit [11].

Chip Power-Down Mode

This mode provides the lowest power state for the KSZ9031MNX device when it is mounted on the board but not in use. Chip power-down (CPD) mode is enabled after power-up/reset with the MODE[3:0] strap-in pins set to '0111'. The KSZ9031MNX exits CPD mode after a hardware reset is applied to the RESET_N pin (pin 56) with the MODE[3:0] strap-in pins set to an operating mode other than CPD.

Energy Efficient Ethernet (EEE)

The KSZ9031MNX implements Energy Efficient Ethernet (EEE), as described in IEEE Standard 802.3az. The Standard is defined around an EEE-compliant MAC on the host side and an EEE-compliant link partner on the line side that support the special signaling associated with EEE. EEE saves power by keeping the AC signal on the copper Ethernet cable at approximately 0V peak-to-peak as often as possible during periods of no traffic activity, while maintaining the link-up status. This is referred to as low-power idle (LPI) mode or state.

During LPI mode, the copper link responds automatically when it receives traffic and resumes normal PHY operation immediately, without blockage of traffic or loss of packet. This involves exiting LPI mode and returning to normal 100/1000Mbps operating mode. Wake-up times are $<16\mu\text{s}$ for 1000Base-T and $<30\mu\text{s}$ for 100Base-TX.

The LPI state is controlled independently for transmit and receive paths, allowing the LPI state to be active (enabled) for:

- Transmit cable path only
- Receive cable path only
- Both transmit and receive cable paths

The KSZ9031MNX has the EEE function disabled as the power-up default setting. The EEE function is enabled by setting the following EEE advertisement bits at MMD address 7h, register 3Ch, followed by restarting auto-negotiation (writing a '1' to register 0h, bit [9]):

- Bit [2] = 1 // Enable 1000Mbps EEE mode
- Bit [1] = 1 // Enable 100Mbps EEE mode

For standard (non-EEE) 10Base-T mode, normal link pulses (NLPs) with long periods of no AC signal transmission are used to maintain the link during the idle period when there is no traffic activity. To save more power, the KSZ9031MNX provides the option to enable 10Base-Te mode, which saves additional power by reducing the transmitted signal amplitude from 2.5V to 1.75V. To enable 10Base-Te mode, write a '1' to MMD address 1Ch, register 4h, bit [10].

During LPI mode, refresh transmissions are used to maintain the link; power savings occur in quiet periods. Approximately every 20 to 22 milliseconds, a refresh transmission of 200 to 220 microseconds is sent to the link partner. The refresh transmissions and quiet periods are shown in Figure 8.

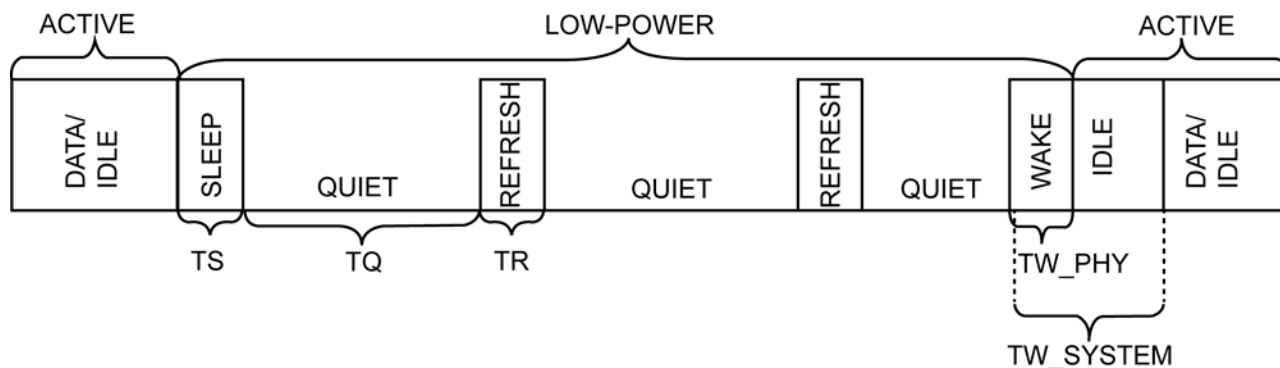

Figure 8. LPI Mode (Refresh Transmissions and Quiet Periods)

Transmit Direction Control (MAC-to-PHY)

The KSZ9031MNX enters LPI mode for the transmit direction when its attached EEE-compliant MAC de-asserts TX_EN, asserts TX_ER, and sets TXD[7:0] to 0000_0001 for GMII (1000Mbps) or TXD[3:0] to 0001 for MII (100Mbps). The KSZ9031MNX remains in the transmit LPI state while the MAC maintains the states of these signals. When the MAC changes any of the TX_EN, TX_ER, or TX data signals from their LPI state values, the KSZ9031MNX exits the LPI transmit state.

For GMII (1000Mbps), the GTX_CLK clock can be stopped by the MAC to save additional power, after the GMII signals for the LPI state have been asserted for nine or more GTX_CLK clock cycles.

Figure 9 shows the LPI transition for GMII transmit.

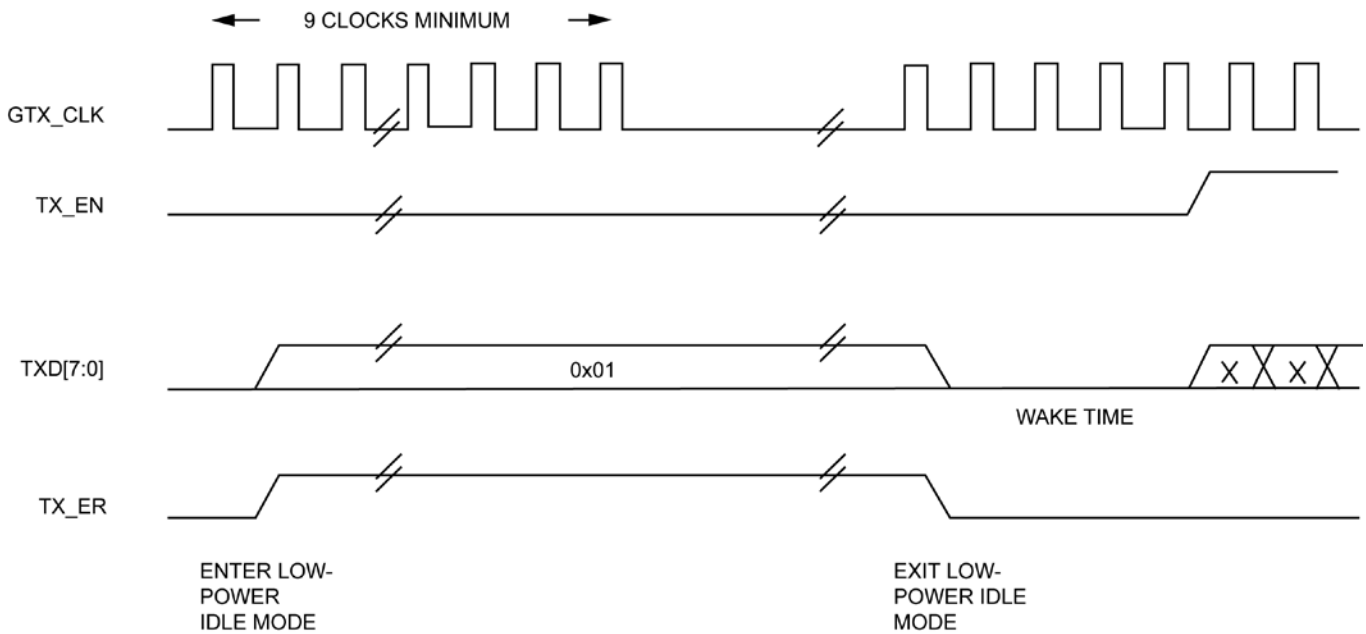

Figure 9. LPI Transition – GMII (1000Mbps) Transmit

For MII (100Mbps), the TX_CLK is not stopped, because it is sourced from the PHY and is used by the MAC for MII transmit.

Figure 10 shows the LPI transition for MII transmit.

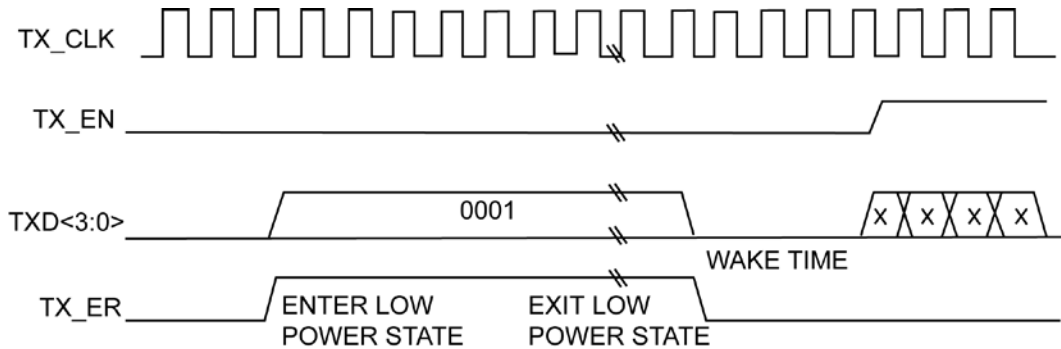

Figure 10. LPI Transition – MII (100Mbps) Transmit

Receive Direction Control (PHY-to-MAC)

The KSZ9031MNX enters LPI mode for the receive direction when it receives the /P/ code bit pattern (Sleep/Refresh) from its EEE-compliant link partner. It then de-asserts RX_DV, asserts RX_ER, and drives RXD[7:0] to 0000_0001 for GMII (1000Mbps) or RXD[3:0] to 0001 for MII (100Mbps). The KSZ9031MNX remains in the receive LPI state while it continues to receive the refresh from its link partner, so it will continue to maintain and drive the LPI output states for the GMII/MII receive signals to inform the attached EEE-compliant MAC that it is in the receive LPI state. When the KSZ9031MNX receives a non /P/ code bit pattern (non-refresh), it exits the receive LPI state and sets the RX_DV, RX_ER, and RX data signals to set a normal frame or normal idle.

For GMII (1000Mbps), the KSZ9031MNX stops the RX_CLK clock output to the MAC after nine or more RX_CLK clock cycles have occurred in the receive LPI state, to save more power.

Figure 11 shows the LPI transition for GMII receive.

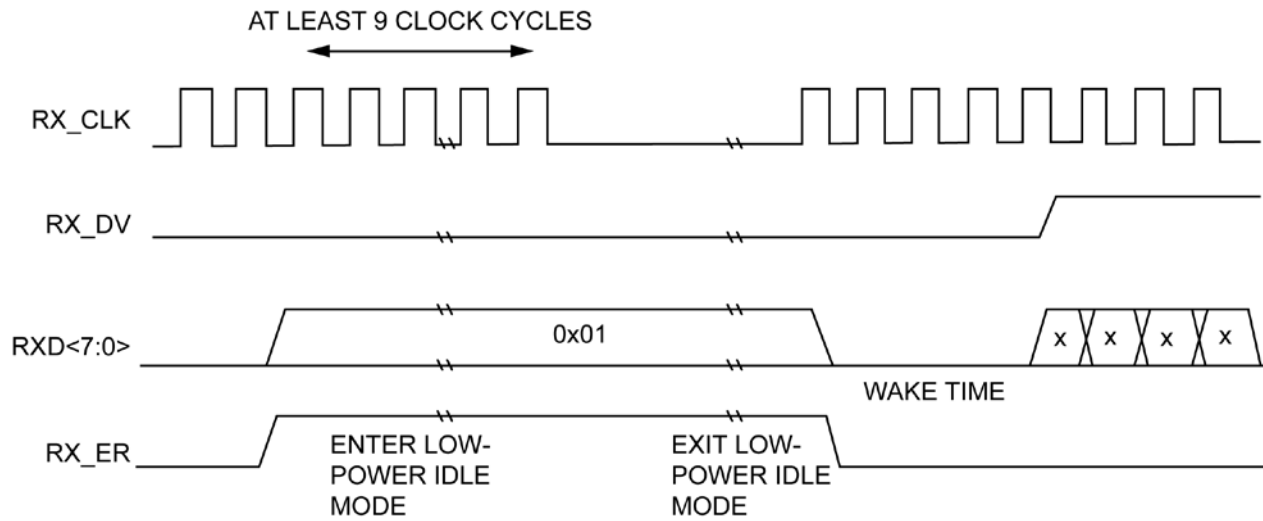

Figure 11. LPI Transition – GMII (1000Mbps) Receive

Similarly, for MII (100Mbps), the KSZ9031MNX stops the RX_CLK clock output to the MAC after nine or more RX_CLK clock cycles have occurred in the receive LPI state, to save more power.

Figure 12 shows the LPI transition for MII receive.

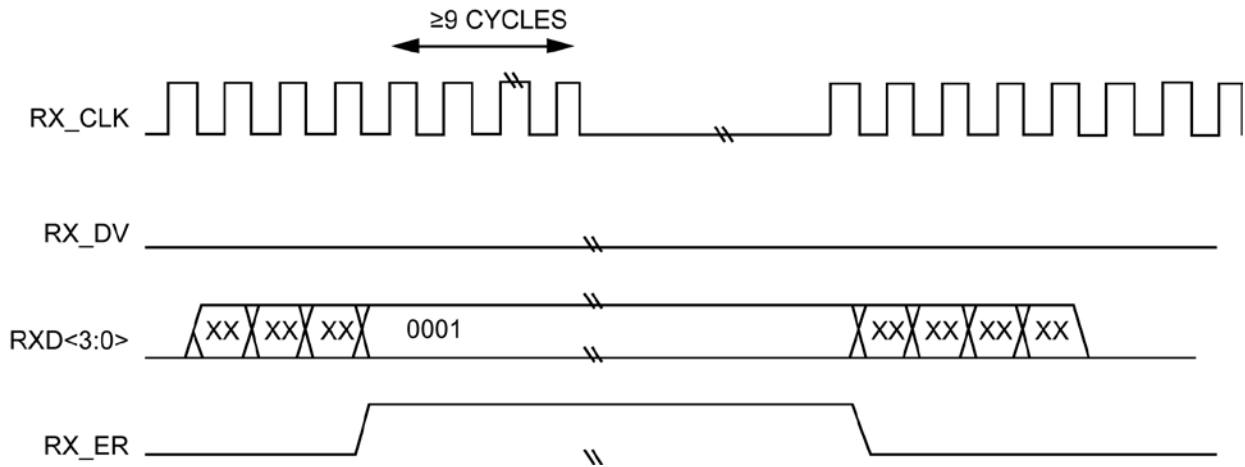

Figure 12. LPI Transition – MII (100Mbps) Receive

Registers Associated with EEE

The following MMD registers are provided for EEE configuration and management:

- MMD address 3h, register 0h - PCS EEE – Control register
- MMD address 3h, register 1h - PCS EEE – Status register
- MMD address 7h, register 3Ch - EEE Advertisement register
- MMD address 7h, register 3Dh - EEE Link Partner Advertisement register

Wake-On-LAN

Wake-On-LAN (WOL) is normally a MAC-based function to wake up a host system (for example, an Ethernet end device, such as a PC) that is in standby power mode. Wake-up is triggered by receiving and detecting a special packet (commonly referred to as the “magic packet”) that is sent by the remote link partner. The KSZ9031MNX can perform the same WOL function if the MAC address of its associated MAC device is entered into the KSZ9031MNX PHY registers for magic-packet detection. When it detects the magic packet, the KSZ9031MNX wakes up the host by driving its power management event (PME) output pin low.

By default, the WOL function is disabled. It is enabled by setting the enabling bit and configuring the associated registers for the selected PME wake-up detection method.

The KSZ9031MNX provides three methods to trigger a PME wake-up:

- Magic-packet detection
- Customized-packet detection
- Link status change detection

Magic-Packet Detection

The magic packet’s frame format starts with 6 bytes of 0xFFh and is followed by 16 repetitions of the MAC address of its associated MAC device (local MAC device).

When the magic packet is detected from its link partner, the KSZ9031MNX asserts its PME output pin low.

The following MMD address 2h registers are provided for magic-packet detection:

- Magic-packet detection is enabled by writing a ‘1’ to MMD address 2h, register 10h, bit [6]
- The MAC address (for the local MAC device) is written to and stored in MMD address 2h, registers 11h – 13h

The KSZ9031MNX does not generate the magic packet. The magic packet must be provided by the external system.

Customized-Packet Detection

The customized packet has associated register/bit masks to select which byte, or bytes, of the first 64 bytes of the packet to use in the CRC calculation. After the KSZ9031MNX receives the packet from its link partner, the selected bytes for the received packet are used to calculate the CRC. The calculated CRC is compared to the expected CRC value that was previously written to and stored in the KSZ9031MNX PHY registers. If there is a match, the KSZ9031MNX asserts its PME output pin low.

Four customized packets are provided to support four types of wake-up scenarios. A dedicated set of registers is used to configure and enable each customized packet.

The following MMD registers are provided for customized-packet detection:

- Each of the four customized packets is enabled via MMD address 2h, register 10h,
 - Bit [2] // For customized packets, type 0
 - Bit [3] // For customized packets, type 1
 - Bit [4] // For customized packets, type 2
 - Bit [5] // For customized packets, type 3
- 32-bit expected CRCs are written to and stored in:
 - MMD address 2h, registers 14h – 15h // For customized packets, type 0
 - MMD address 2h, registers 16h – 17h // For customized packets, type 1
 - MMD address 2h, registers 18h – 19h // For customized packets, type 2
 - MMD address 2h, registers 1Ah – 1Bh // For customized packets, type 3
- Masks to indicate which of the first 64-bytes to use in the CRC calculation are set in:
 - MMD address 2h, registers 1Ch – 1Fh // For customized packets, type 0
 - MMD address 2h, registers 20h – 23h // For customized packets, type 1
 - MMD address 2h, registers 24h – 27h // For customized packets, type 2
 - MMD address 2h, registers 28h – 2Bh // For customized packets, type 3

- 32-bit calculated CRCs (of receive packet) are stored in:
 - MMD address 2h, registers 30h – 31h // For customized packets, type 0
 - MMD address 2h, registers 32h – 33h // For customized packets, type 1
 - MMD address 2h, registers 34h – 35h // For customized packets, type 2
 - MMD address 2h, registers 36h – 37h // For customized packets, type 3

Link Status Change Detection

If link status change detection is enabled, the KSZ9031MNX asserts its PME output pin low whenever there is a link status change, using the following MMD address 2h register bits and their enabled (1) or disabled (0) settings:

- MMD address 2h, register 10h, bit [0] // For link-up detection
- MMD address 2h, register 10h, bit [1] // For link-down detection

The PME output signal is available on either LED1/PME_N1 (pin 19) or INT_N/PME_N2 (pin 53), and is selected and enabled using MMD address 2h, register 2h, bits [8] and [10], respectively. Additionally, MMD address 2h, register 10h, bits [15:14] defines the output functions for pins 19 and 53.

The PME output is active low and requires a 1k Ω pull-up to the VDDIO supply. When asserted, the PME output is cleared by disabling the register bit that enabled the PME trigger source (magic packet, customized packet, link status change).

Typical Current/Power Consumption

Table 9 through Table 12 show the typical current consumption by the core (DVDDL, AVDDL, AVDDL_PLL), transceiver (AVDDH) and digital I/O (DVDDH) supply pins, and the total typical power for the entire KSZ9031MNX device for various nominal operating voltage combinations.

Transceiver (3.3V), Digital I/Os (3.3V)

Condition	1.2V Core (DVDDL, AVDDL, AVDDL_PLL)	3.3V Transceiver (AVDDH)	3.3V Digital I/Os (DVDDH)	Total Chip Power
	mA	mA	mA	mW
1000Base-T link-up (no traffic)	211	66.6	26.0	560
1000Base-T full-duplex @ 100% utilization	221	65.6	53.8	660
100Base-TX link-up (no traffic)	60.6	28.7	13.3	211
100Base-TX full-duplex @ 100% utilization	61.2	28.7	18.0	228
10Base-T link-up (no traffic)	7.0	17.0	5.7	83
10Base-T full-duplex @ 100% utilization	7.7	29.3	11.1	143
EEE Mode – 1000Mbps	41.6	5.5	3.7	80
EEE Mode – 100Mbps (TX and RX in LPI)	25.3	5.2	7.0	71
Software power-down mode (Reg. 0h.11 = 1)	0.9	4.1	7.1	38

Table 9. Typical Current/Power Consumption – Transceiver (3.3V), Digital I/Os (3.3V)

Transceiver (3.3V), Digital I/Os (1.8V)

Condition	1.2V Core (DVDDL, AVDDL, AVDDL_PLL)	3.3V Transceiver (AVDDH)	1.8V Digital I/Os (DVDDH)	Total Chip Power
	mA	mA	mA	mW
1000Base-T link-up (no traffic)	211	66.6	14.2	498
1000Base-T full-duplex @ 100% utilization	221	65.6	29.3	534
100Base-TX link-up (no traffic)	60.6	28.7	7.3	181
100Base-TX full-duplex @ 100% utilization	61.2	28.7	10.0	186
10Base-T link-up (no traffic)	7.0	17.0	3.1	70
10Base-T full-duplex @ 100% utilization	7.7	29.3	6.0	117
EEE Mode – 1000Mbps	41.6	5.5	2.4	72
EEE Mode – 100Mbps (TX and RX in LPI)	25.3	5.2	3.8	54
Software power-down mode (Reg. 0h.11 = 1)	0.9	4.1	3.7	21

Table 10. Typical Current/Power Consumption – Transceiver (3.3V), Digital I/Os (1.8V)

Transceiver (2.5V), Digital I/Os (2.5V)

Condition	1.2V Core (DVDDL, AVDDL, AVDDL_PLL)	2.5V Transceiver ⁽¹⁾ (AVDDH – commercial temp only)	2.5V Digital I/Os (DVDDH)	Total Chip Power
	mA	mA	mA	mW
1000Base-T link-up (no traffic)	211	58.6	19.3	448
1000Base-T full-duplex @ 100% utilization	221	57.6	40.5	510
100Base-TX link-up (no traffic)	60.6	24.8	10.0	160
100Base-TX full-duplex @ 100% utilization	61.2	24.8	13.7	170
10Base-T link-up (no traffic)	7.0	12.5	4.3	50
10Base-T full-duplex @ 100% utilization	7.7	25.8	8.3	94
EEE Mode – 1000Mbps	41.6	4.4	2.9	68
EEE Mode – 100Mbps (TX and RX in LPI)	25.3	4.0	5.2	53
Software power-down mode (Reg. 0h.11 = 1)	0.9	3.0	5.3	22

Table 11. Typical Current/Power Consumption – Transceiver (2.5V), Digital I/Os (2.5V)**Transceiver (2.5V), Digital I/Os (1.8V)**

Condition	1.2V Core (DVDDL, AVDDL, AVDDL_PLL)	2.5V Transceiver ⁽¹⁾ (AVDDH – commercial temp only) *	1.8V Digital I/Os (DVDDH)	Total Chip Power
	mA	mA	mA	mW
1000Base-T link-up (no traffic)	211	58.6	14.2	425
1000Base-T full-duplex @ 100% utilization	221	57.6	29.3	462
100Base-TX link-up (no traffic)	60.6	24.8	7.3	148
100Base-TX full-duplex @ 100% utilization	61.2	24.8	10.0	153
10Base-T link-up (no traffic)	7.0	12.5	3.1	45
10Base-T full-duplex @ 100% utilization	7.7	25.8	6.0	85
EEE Mode – 1000Mbps	41.6	4.4	2.4	65
EEE Mode – 100Mbps (TX and RX in LPI)	25.3	4.0	3.8	47
Software power-down mode (Reg. 0h.11 = 1)	0.9	3.0	3.7	15

Table 12. Typical Current/Power Consumption – Transceiver (2.5V), Digital I/Os (1.8V)**Note:**

1. 2.5V AVDDH is recommended for commercial temperature range (0°C to +70°C) operation only.

Register Map

The register space within the KSZ9031MNX consists of two distinct areas.

- Standard registers // Direct register access
- MDIO manageable device (MMD) registers // Indirect register access

The KSZ9031MNX supports the following standard registers.

Register Number (Hex)	Description
IEEE-Defined Registers	
0h	Basic Control
1h	Basic Status
2h	PHY Identifier 1
3h	PHY Identifier 2
4h	Auto-Negotiation Advertisement
5h	Auto-Negotiation Link Partner Ability
6h	Auto-Negotiation Expansion
7h	Auto-Negotiation Next Page
8h	Auto-Negotiation Link Partner Next Page Ability
9h	1000Base-T Control
Ah	1000Base-T Status
Bh – Ch	Reserved
Dh	MMD Access – Control
Eh	MMD Access – Register/Data
Fh	Extended Status
Vendor-Specific Registers	
10h	Reserved
11h	Remote Loopback
12h	LinkMD Cable Diagnostic
13h	Digital PMA/PCS Status
14h	Reserved
15h	RXER Counter
16h – 1Ah	Reserved
1Bh	Interrupt Control/Status
1Ch	Auto MDI/MDI-X
1Dh – 1Eh	Reserved
1Fh	PHY Control

Table 13. Standard Registers Supported by KSZ9031MNX

The KSZ9031MNX supports the following MMD device addresses and their associated register addresses, which make up the indirect MMD registers.

Device Address (Hex)	Register Address (Hex)	Description
1h	5Ah	1000Base-T Link-Up Time Control
2h	0h	Common Control
	1h	Strap Status
	2h	Operation Mode Strap Override
	3h	Operation Mode Strap Status
	4h	GMII Control Signal Pad Skew
	8h	GMII Clock Pad Skew
	10h	Wake-On-LAN – Control
	11h	Wake-On-LAN – Magic Packet, MAC-DA-0
	12h	Wake-On-LAN – Magic Packet, MAC-DA-1
	13h	Wake-On-LAN – Magic Packet, MAC-DA-2
	14h	Wake-On-LAN – Customized Packet, Type 0, Expected CRC 0
	15h	Wake-On-LAN – Customized Packet, Type 0, Expected CRC 1
	16h	Wake-On-LAN – Customized Packet, Type 1, Expected CRC 0
	17h	Wake-On-LAN – Customized Packet, Type 1, Expected CRC 1
	18h	Wake-On-LAN – Customized Packet, Type 2, Expected CRC 0
	19h	Wake-On-LAN – Customized Packet, Type 2, Expected CRC 1
	1Ah	Wake-On-LAN – Customized Packet, Type 3, Expected CRC 0
	1Bh	Wake-On-LAN – Customized Packet, Type 3, Expected CRC 1
	1Ch	Wake-On-LAN – Customized Packet, Type 0, Mask 0
	1Dh	Wake-On-LAN – Customized Packet, Type 0, Mask 1
	1Eh	Wake-On-LAN – Customized Packet, Type 0, Mask 2
	1Fh	Wake-On-LAN – Customized Packet, Type 0, Mask 3
	20h	Wake-On-LAN – Customized Packet, Type 1, Mask 0
	21h	Wake-On-LAN – Customized Packet, Type 1, Mask 1
	22h	Wake-On-LAN – Customized Packet, Type 1, Mask 2
	23h	Wake-On-LAN – Customized Packet, Type 1, Mask 3
	24h	Wake-On-LAN – Customized Packet, Type 2, Mask 0
	25h	Wake-On-LAN – Customized Packet, Type 2, Mask 1
	26h	Wake-On-LAN – Customized Packet, Type 2, Mask 2
	27h	Wake-On-LAN – Customized Packet, Type 2, Mask 3
28h	Wake-On-LAN – Customized Packet, Type 3, Mask 0	
29h	Wake-On-LAN – Customized Packet, Type 3, Mask 1	
2Ah	Wake-On-LAN – Customized Packet, Type 3, Mask 2	
2Bh	Wake-On-LAN – Customized Packet, Type 3, Mask 3	
3h	0h	PCS EEE – Control
	1h	PCS EEE – Status
7h	3Ch	EEE Advertisement
	3Dh	EEE Link Partner Advertisement
1Ch	4h	Analog Control 4
	23h	EDPD Control

Table 14. MMD Registers Supported by KSZ9031MNX

Standard Registers

Standard registers provide direct read/write access to a 32-register address space, as defined in Clause 22 of the IEEE 802.3 Specification. Within this address space, the first 16 registers (registers 0h to Fh) are defined according to the IEEE specification, while the remaining 16 registers (registers 10h to 1Fh) are defined specific to the PHY vendor.

IEEE Defined Registers – Descriptions

Address	Name	Description	Mode ⁽¹⁾	Default
Register 0h – Basic Control				
0.15	Reset	1 = Software PHY reset 0 = Normal operation This bit is self-cleared after a '1' is written to it.	RW/SC	0
0.14	Loopback	1 = Loopback mode 0 = Normal operation	RW	0
0.13	Speed Select (LSB)	[0.6, 0.13] [1,1] = Reserved [1,0] = 1000Mbps [0,1] = 100Mbps [0,0] = 10Mbps This bit is ignored if auto-negotiation is enabled (Reg. 0.12 = 1).	RW	0
0.12	Auto-Negotiation Enable	1 = Enable auto-negotiation process 0 = Disable auto-negotiation process If enabled, auto-negotiation result overrides settings in Reg. 0.13, 0.8 and 0.6.	RW	1
0.11	Power-Down	1 = Power-down mode 0 = Normal operation	RW	0
0.10	Isolate	1 = Electrical isolation of PHY from GMII/MII 0 = Normal operation	RW	0
0.9	Restart Auto-Negotiation	1 = Restart auto-negotiation process 0 = Normal operation This bit is self-cleared after a '1' is written to it.	RW/SC	0
0.8	Duplex Mode	1 = Full-duplex 0 = Half-duplex	RW	1
0.7	Collision Test	1 = Enable COL test 0 = Disable COL test	RW	0
0.6	Speed Select (MSB)	[0.6, 0.13] [1,1] = Reserved [1,0] = 1000Mbps [0,1] = 100Mbps [0,0] = 10Mbps This bit is ignored if auto-negotiation is enabled (Reg. 0.12 = 1).	RW	Set by MODE[3:0] strapping pins. See the " Strapping Options " section for details.
0.5:0	Reserved	Reserved	RO	00_0000

Address	Name	Description	Mode ⁽¹⁾	Default
Register 1h – Basic Status				
1.15	100Base-T4	1 = T4 capable 0 = Not T4 capable	RO	0
1.14	100Base-TX Full-Duplex	1 = Capable of 100Mbps full-duplex 0 = Not capable of 100Mbps full-duplex	RO	1
1.13	100Base-TX Half-Duplex	1 = Capable of 100Mbps half-duplex 0 = Not capable of 100Mbps half-duplex	RO	1
1.12	10Base-T Full-Duplex	1 = Capable of 10Mbps full-duplex 0 = Not capable of 10Mbps full-duplex	RO	1
1.11	10Base-T Half-Duplex	1 = Capable of 10Mbps half-duplex 0 = Not capable of 10Mbps half-duplex	RO	1
1.10:9	Reserved	Reserved	RO	00
1.8	Extended Status	1 = Extended status info in Reg. 15h. 0 = No extended status info in Reg. 15h.	RO	1
1.7	Reserved	Reserved	RO	0
1.6	No Preamble	1 = Preamble suppression 0 = Normal preamble	RO	1
1.5	Auto-Negotiation Complete	1 = Auto-negotiation process completed 0 = Auto-negotiation process not completed	RO	0
1.4	Remote Fault	1 = Remote fault 0 = No remote fault	RO/LH	0
1.3	Auto-Negotiation Ability	1 = Can perform auto-negotiation 0 = Cannot perform auto-negotiation	RO	1
1.2	Link Status	1 = Link is up 0 = Link is down	RO/LL	0
1.1	Jabber Detect	1 = Jabber detected 0 = Jabber not detected (default is low)	RO/LH	0
1.0	Extended Capability	1 = Supports extended capability registers	RO	1
Register 2h – PHY Identifier 1				
2.15:0	PHY ID Number	Assigned to the 3rd through 18th bits of the organizationally unique identifier (OUI). KENDIN Communication's OUI is 0010A1h.	RO	0022h
Register 3h – PHY Identifier 2				
3.15:10	PHY ID Number	Assigned to the 19th through 24th bits of the organizationally unique identifier (OUI). KENDIN Communication's OUI is 0010A1h.	RO	0001_01
3.9:4	Model Number	Six-bit manufacturer's model number	RO	10_0010
3.3:0	Revision Number	Four-bit manufacturer's revision number	RO	Indicates silicon revision
Register 4h – Auto-Negotiation Advertisement				
4.15	Next Page	1 = Next page capable 0 = No next page capability	RW	0

Address	Name	Description	Mode ⁽¹⁾	Default
4.14	Reserved	Reserved	RO	0
4.13	Remote Fault	1 = Remote fault supported 0 = No remote fault	RW	0
4.12	Reserved	Reserved	RO	0
4.11:10	Pause	[4.11, 4.10] [0,0] = No pause [1,0] = Asymmetric pause (link partner) [0,1] = Symmetric pause [1,1] = Symmetric and asymmetric pause (local device)	RW	00
4.9	100Base-T4	1 = T4 capable 0 = No T4 capability	RO	0
4.8	100Base-TX Full-Duplex	1 = 100Mbps full-duplex capable 0 = No 100Mbps full-duplex capability	RW	1
4.7	100Base-TX Half-Duplex	1 = 100Mbps half-duplex capable 0 = No 100Mbps half-duplex capability	RW	1
4.6	10Base-T Full-Duplex	1 = 10Mbps full-duplex capable 0 = No 10Mbps full-duplex capability	RW	1
4.5	10Base-T Half-Duplex	1 = 10Mbps half-duplex capable 0 = No 10Mbps half-duplex capability	RW	1
4.4:0	Selector Field	[00001] = IEEE 802.3	RW	0_0001
Register 5h – Auto-Negotiation Link Partner Ability				
5.15	Next Page	1 = Next page capable 0 = No next page capability	RO	0
5.14	Acknowledge	1 = Link code word received from partner 0 = Link code word not yet received	RO	0
5.13	Remote Fault	1 = Remote fault detected 0 = No remote fault	RO	0
5.12	Reserved	Reserved	RO	0
5.11:10	Pause	[5.11, 5.10] [0,0] = No pause [1,0] = Asymmetric Pause (link partner) [0,1] = Symmetric pause [1,1] = Symmetric and asymmetric pause (local device)	RW	00
5.9	100Base-T4	1 = T4 capable 0 = No T4 capability	RO	0
5.8	100Base-TX Full-Duplex	1 = 100Mbps full-duplex capable 0 = No 100Mbps full-duplex capability	RO	0
5.7	100Base-TX Half-Duplex	1 = 100Mbps half-duplex capable 0 = No 100Mbps half-duplex capability	RO	0
5.6	10Base-T Full-Duplex	1 = 10Mbps full-duplex capable 0 = No 10Mbps full-duplex capability	RO	0

Address	Name	Description	Mode ⁽¹⁾	Default
5.5	10Base-T Half-Duplex	1 = 10Mbps half-duplex capable 0 = No 10Mbps half-duplex capability	RO	0
5.4:0	Selector Field	[00001] = IEEE 802.3	RO	0_0000
Register 6h – Auto-Negotiation Expansion				
6.15:5	Reserved	Reserved	RO	0000_0000_000
6.4	Parallel Detection Fault	1 = Fault detected by parallel detection 0 = No fault detected by parallel detection	RO/LH	0
6.3	Link Partner Next Page Able	1 = Link partner has next page capability 0 = Link partner does not have next page capability	RO	0
6.2	Next Page Able	1 = Local device has next page capability 0 = Local device does not have next page capability	RO	1
6.1	Page Received	1 = New page received 0 = New page not received	RO/LH	0
6.0	Link Partner Auto-Negotiation Able	1 = Link partner has auto-negotiation capability 0 = Link partner does not have auto-negotiation capability	RO	0
Register 7h – Auto-Negotiation Next Page				
7.15	Next Page	1 = Additional next pages will follow 0 = Last page	RW	0
7.14	Reserved	Reserved	RO	0
7.13	Message Page	1 = Message page 0 = Unformatted page	RW	1
7.12	Acknowledge2	1 = Will comply with message 0 = Cannot comply with message	RW	0
7.11	Toggle	1 = Previous value of the transmitted link code word equaled logic one 0 = Logic zero	RO	0
7.10:0	Message Field	11-bit wide field to encode 2048 messages	RW	000_0000_0001
Register 8h – Auto-Negotiation Link Partner Next Page Ability				
8.15	Next Page	1 = Additional next pages will follow 0 = Last page	RO	0
8.14	Acknowledge	1 = Successful receipt of link word 0 = No successful receipt of link word	RO	0
8.13	Message Page	1 = Message page 0 = Unformatted page	RO	0
8.12	Acknowledge2	1 = Able to act on the information 0 = Not able to act on the information	RO	0
8.11	Toggle	1 = Previous value of transmitted link code word equal to logic zero 0 = Previous value of transmitted link code word equal to logic one	RO	0
8.10:0	Message Field		RO	000_0000_0000

Address	Name	Description	Mode ⁽¹⁾	Default
Register 9h – 1000Base-T Control				
9.15:13	Test Mode Bits	Transmitter test mode operations [9.15:13] Mode [000] Normal operation [001] Test mode 1 –Transmit waveform test [010] Test mode 2 –Transmit jitter test in master mode [011] Test mode 3 –Transmit jitter test in slave mode [100] Test mode 4 –Transmitter distortion test [101] Reserved, operations not identified [110] Reserved, operations not identified [111] Reserved, operations not identified	RW	000
9.12	Master-Slave Manual Configuration Enable	1 = Enable master-slave manual configuration value 0 = Disable master-slave manual configuration value	RW	0
9.11	Master-Slave Manual Configuration Value	1 = Configure PHY as master during master-slave negotiation 0 = Configure PHY as slave during master-slave negotiation This bit is ignored if master-slave manual configuration is disabled (Reg. 9.12 = 0).	RW	0
9.10	Port Type	1 = Indicate the preference to operate as multiport device (master) 0 = Indicate the preference to operate as single-port device (slave) This bit is valid only if master-slave manual configuration is disabled (Reg. 9.12 = 0).	RW	0
9.9	1000Base-T Full-Duplex	1 = Advertise PHY is 1000Base-T full-duplex capable 0 = Advertise PHY is not 1000Base-T full-duplex capable	RW	1
9.8	1000Base-T Half-Duplex	1 = Advertise PHY is 1000Base-T half-duplex capable 0 = Advertise PHY is not 1000Base-T half-duplex capable	RW	Set by MODE[3:0] strapping pins. See the “ Strapping Options ” section for details.
9.7:0	Reserved	Write as 0, ignore on read	RO	
Register Ah – 1000Base-T Status				
A.15	Master-Slave Configuration Fault	1 = Master-slave configuration fault detected 0 = No master-slave configuration fault detected	RO/LH/SC	0

Address	Name	Description	Mode ⁽¹⁾	Default
A.14	Master-Slave Configuration Resolution	1 = Local PHY configuration resolved to master 0 = Local PHY configuration resolved to slave	RO	0
A.13	Local Receiver Status	1 = Local receiver OK (loc_rcvr_status = 1) 0 = Local receiver not OK (loc_rcvr_status = 0)	RO	0
A.12	Remote Receiver Status	1 = Remote receiver OK (rem_rcvr_status = 1) 0 = Remote receiver not OK (rem_rcvr_status = 0)	RO	0
A.11	Link Partner 1000Base-T Full-Duplex Capability	1 = Link partner is capable of 1000Base-T full-duplex 0 = Link partner is not capable of 1000Base-T full-duplex	RO	0
A.10	Link Partner 1000Base-T Half-Duplex Capability	1 = Link partner is capable of 1000Base-T half-duplex 0 = Link Partner is not capable of 1000Base-T half-duplex	RO	0
A.9:8	Reserved	Reserved	RO	00
A.7:0	Idle Error Count	Cumulative count of errors detected when receiver is receiving idles and PMA_TXMODE.indicate = SEND_N. The counter is incremented every symbol period that rxerror_status = ERROR.	RO/SC	0000_0000
Register Dh – MMD Access – Control				
D.15:14	MMD – Operation Mode	For the selected MMD device address (bits [4:0] of this register), these two bits select one of the following register or data operations and the usage for MMD Access – Register/Data (Reg. Eh). 00 = Register 01 = Data, no post increment 10 = Data, post increment on reads and writes 11 = Data, post increment on writes only	RW	00
D.13:5	Reserved	Reserved	RW	00_0000_000
D.4:0	MMD – Device Address	These five bits set the MMD device address.	RW	0_0000
Register Eh – MMD Access – Register/Data				
E.15:0	MMD – Register/Data	For the selected MMD device address (Reg. Dh, bits [4:0]), When Reg. Dh, bits [15:14] = 00, this register contains the read/write register address for the MMD device address. Otherwise, this register contains the read/write data value for the MMD device address and its selected register address. See also Reg. Dh, bits [15:14], for descriptions of post increment reads and writes of this register for data operation.	RW	0000_0000_0000_0000

Address	Name	Description	Mode ⁽¹⁾	Default
Register Fh – Extended Status				
F.15	1000Base-X Full-Duplex	1 = PHY can perform 1000Base-X full-duplex 0 = PHY cannot perform 1000Base-X full-duplex	RO	0
F.14	1000Base-X Half-Duplex	1 = PHY can perform 1000Base-X half-duplex 0 = PHY cannot perform 1000Base-X half-duplex	RO	0
F.13	1000Base-T Full-Duplex	1 = PHY can perform 1000Base-T full-duplex 0 = PHY cannot perform 1000Base-T full-duplex	RO	1
F.12	1000Base-T Half-Duplex	1 = PHY can perform 1000Base-T half-duplex 0 = PHY cannot perform 1000Base-T half-duplex	RO	1
F.11:0	Reserved	Ignore when read	RO	-

Note:

1. RW = Read/Write.
RO = Read only.
SC = Self-cleared.
LH = Latch high.
LL = Latch low.

Vendor-Specific Registers – Descriptions

Address	Name	Description	Mode ⁽¹⁾	Default
Register 11h – Remote Loopback				
11.15:9	Reserved	Reserved	RW	0000_000
11.8	Remote Loopback	1 = Enable remote loopback 0 = Disable remote loopback	RW	0
11.7:1	Reserved	Reserved	RW	1111_010
11.0	Reserved	Reserved	RO	0
Register 12h – LinkMD – Cable Diagnostic				
12.15	Cable Diagnostic Test Enable	Write value: 1 = Enable cable diagnostic test. After test has completed, this bit is self-cleared. 0 = Disable cable diagnostic test. Read value: 1 = Cable diagnostic test is in progress. 0 = Indicates cable diagnostic test (if enabled) has completed and the status information is valid for read.	RW/SC	0
12.14	Reserved	This bit should always be set to '0'.	RW	0
12.13:12	Cable Diagnostic Test Pair	These two bits select the differential pair for testing: 00 = Differential pair A (pins 2, 3) 01 = Differential pair B (pins 5, 6) 10 = Differential pair C (pins 7, 8) 11 = Differential pair D (pins 10, 11)	RW	00
12.11:10	Reserved	These two bits should always be set to '00'.	RW	00
12.9:8	Cable Diagnostic Status	These two bits represent the test result for the selected differential pair in bits [13:12] of this register. 00 = Normal cable condition (no fault detected) 01 = Open cable fault detected 10 = Short cable fault detected 11 = Reserved	RO	00
12.7:0	Cable Diagnostic Fault Data	For the open or short cable fault detected in bits [9:8] of this register, this 8-bit value represents the distance to the cable fault.	RO	0000_0000
Register 13h – Digital PMA/PCS Status				
13.15:3	Reserved	Reserved	RO/LH	0000_0000_0000_0
13.2	1000Base-T Link Status	1000Base-T link status 1 = Link status is OK 0 = Link status is not OK	RO	0
13.1	100Base-TX Link Status	100Base-TX link status 1 = Link status is OK 0 = Link status is not OK	RO	0
13.0	Reserved	Reserved	RO	0

Address	Name	Description	Mode ⁽¹⁾	Default
Register 15h – RXER Counter				
15.15:0	RXER Counter	Receive error counter for symbol error frames	RO/RC	0000_0000_0000_0000
Register 1Bh – Interrupt Control/Status				
1B.15	Jabber Interrupt Enable	1 = Enable jabber interrupt 0 = Disable jabber interrupt	RW	0
1B.14	Receive Error Interrupt Enable	1 = Enable receive error interrupt 0 = Disable receive error interrupt	RW	0
1B.13	Page Received Interrupt Enable	1 = Enable page received interrupt 0 = Disable page received interrupt	RW	0
1B.12	Parallel Detect Fault Interrupt Enable	1 = Enable parallel detect fault interrupt 0 = Disable parallel detect fault interrupt	RW	0
1B.11	Link Partner Acknowledge Interrupt Enable	1 = Enable link partner acknowledge interrupt 0 = Disable link partner acknowledge interrupt	RW	0
1B.10	Link-Down Interrupt Enable	1 = Enable link-down interrupt 0 = Disable link-down interrupt	RW	0
1B.9	Remote Fault Interrupt Enable	1 = Enable remote fault interrupt 0 = Disable remote fault interrupt	RW	0
1B.8	Link-Up Interrupt Enable	1 = Enable link-up interrupt 0 = Disable link-up interrupt	RW	0
1B.7	Jabber Interrupt	1 = Jabber occurred 0 = Jabber did not occur	RO/RC	0
1B.6	Receive Error Interrupt	1 = Receive error occurred 0 = Receive error did not occur	RO/RC	0
1B.5	Page Receive Interrupt	1 = Page receive occurred 0 = Page receive did not occur	RO/RC	0
1B.4	Parallel Detect Fault Interrupt	1 = Parallel detect fault occurred 0 = Parallel detect fault did not occur	RO/RC	0
1B.3	Link Partner Acknowledge Interrupt	1 = Link partner acknowledge occurred 0 = Link partner acknowledge did not occur	RO/RC	0
1B.2	Link-Down Interrupt	1 = Link-down occurred 0 = Link-down did not occur	RO/RC	0
1B.1	Remote Fault Interrupt	1 = Remote fault occurred 0 = Remote fault did not occur	RO/RC	0
1B.0	Link-Up Interrupt	1 = Link-up occurred 0 = Link-up did not occur	RO/RC	0
Register 1Ch – Auto MDI/MDI-X				
1C.15:8	Reserved	Reserved	RW	0000_0000

Address	Name	Description	Mode ⁽¹⁾	Default
1C.7	MDI Set	When Swap-Off (bit [6] of this register) is asserted (1), 1 = PHY is set to operate as MDI mode 0 = PHY is set to operate as MDI-X mode This bit has no function when Swap-Off is de-asserted (0).	RW	0
1C.6	Swap-Off	1 = Disable Auto MDI/MDI-X function 0 = Enable Auto MDI/MDI-X function	RW	0
1C.5:0	Reserved	Reserved	RW	00_0000
Register 1Fh – PHY Control				
1F.15	Reserved	Reserved	RW	0
1F.14	Interrupt Level	1 = Interrupt pin active high 0 = Interrupt pin active low	RW	0
1F.13:12	Reserved	Reserved	RW	00
1F.11:10	Reserved	Reserved	RO/LH/RC	00
1F.9	Enable Jabber	1 = Enable jabber counter 0 = Disable jabber counter	RW	1
1F.8:7	Reserved	Reserved	RW	00
1F.6	Speed Status 1000Base-T	1 = Indicate chip final speed status at 1000Base-T	RO	0
1F.5	Speed Status 100Base-TX	1 = Indicate chip final speed status at 100Base-TX	RO	0
1F.4	Speed Status 10Base-T	1 = Indicate chip final speed status at 10Base-T	RO	0
1F.3	Duplex status	Indicate chip duplex status 1 = Full-duplex 0 = Half-duplex	RO	0
1F.2	1000Base-T Master/Slave Status	Indicate chip master/slave status 1 = 1000Base-T master mode 0 = 1000Base-T slave mode	RO	0
1F.1	Reserved	Reserved	RW	0
1F.0	Link Status Check Fail	1 = Fail 0 = Not failing	RO	0

Note:

1. RW = Read/Write.
RC = Read-cleared
RO = Read only.
SC = Self-cleared.
LH = Latch high.

MMD Registers

MMD registers provide indirect read/write access to up to 32 MMD Device Addresses with each device supporting up to 65,536 16-bit registers, as defined in Clause 22 of the IEEE 802.3 Specification. The KSZ9031MNX, however, uses only a small fraction of the available registers. See the “[Register Map](#)” section for a list of supported MMD device addresses and their associated register addresses.

The following two standard registers serve as the portal registers to access the indirect MMD registers.

- Standard register Dh – MMD Access – Control
- Standard register Eh – MMD Access – Register/Data

Register Dh – MMD Access – Control				
D.15:14	MMD – Operation Mode	For the selected MMD device address (bits [4:0] of this register), these two bits select one of the following register or data operations and the usage for MMD Access – Register/Data (Reg. Eh). 00 = Register 01 = Data, no post increment 10 = Data, post increment on reads and writes 11 = Data, post increment on writes only	RW	00
D.13:5	Reserved	Reserved	RW	00_0000_000
D.4:0	MMD – Device Address	These five bits set the MMD device address.	RW	0_0000
Register Eh – MMD Access – Register/Data				
E.15:0	MMD – Register/Data	For the selected MMD device address (Reg. Dh, bits [4:0]), When Reg. Dh, bits [15:14] = 00, this register contains the read/write register address for the MMD device address. Otherwise, this register contains the read/write data value for the MMD – Device Address and its selected register address. See also Register Dh, bits [15:14] descriptions for post increment reads and writes of this register for data operation.	RW	0000_0000_0000_0000

Table 15. Portal Registers (Access to Indirect MMD Registers)

Examples:

- **MMD Register Write**

Write MMD – Device Address 2h, Register 10h = 0001h to enable link-up detection to trigger PME for WOL.

1. Write register Dh with 0002h // Set up register address for MMD – Device Address 2h.
2. Write register Eh with 0010h // Select register 10h of MMD – Device Address 2h.
3. Write register Dh with 4002h // Select register data for MMD – Device Address 2h, register 10h.
4. Write register Eh with 0001h // Write value 0001h to MMD – Device Address 2h, register 10h.

- **MMD Register Read**

Read MMD – Device Address 2h, Register 11h – 13h for the magic packet’s MAC address

1. Write register Dh with 0002h // Set up register address for MMD – Device Address 2h.
2. Write register Eh with 0011h // Select register 11h of MMD – Device Address 2h.
3. Write register Dh with 8002h // Select register data for MMD – Device Address 2h, register 11h.
4. Read register Eh // Read data in MMD – Device Address 2h, register 11h.
5. Read register Eh // Read data in MMD – Device Address 2h, register 12h.
6. Read register Eh // Read data in MMD – Device Address 2h, register 13h.

MMD Registers – Descriptions

Address	Name	Description	Mode ⁽¹⁾	Default
MMD Address 1h, Register 5Ah – 1000Base-T Link-Up Time Control				
1.5A.15:9	Reserved	Reserved	RO	0000_000
1.5A.8:4	Reserved	Reserved	RW	1_0000
1.5A.3:1	1000Base-T Link-Up Time	<p>When the link partner is another KSZ9031 device, the 1000Base-T link-up time can be long. These three bits provide an optional setting to reduce the 1000Base-T link-up time.</p> <p>100 = Default power-up setting</p> <p>011 = Optional setting to reduce link-up time when the link partner is a KSZ9031 device.</p> <p>All other settings are reserved and should not be used.</p> <p>The optional setting is safe to use with any link partner.</p> <p>Note: Read/Write access to this register bit is available only when Reg. 0h is set to 0x2100 to disable auto-negotiation and force 100Base-TX mode.</p>	RW	100
1.5A.0	Reserved	Reserved	RW	0
MMD Address 2h, Register 0h – Common Control				
2.0.15:4	Reserved	Reserved	RW	0000_0000_0000
2.0.3	LED Mode	<p>Override strap-in for LED_MODE</p> <p>1 = Single-LED mode</p> <p>0 = Bi-color dual-LED mode</p>	RW	<p>Set by LED_MODE strapping pin.</p> <p>See the “Strapping Options” section for details.</p>
2.0.2	Reserved	Reserved	RW	0
2.0.1	CLK125_EN Status	<p>Override strap-in for CLK125_EN</p> <p>1 = CLK125_EN strap-in is enabled</p> <p>0 = CLK125_EN strap-in is disabled</p>	RW	<p>Set by CLK125_EN strapping pin.</p> <p>See the “Strapping Options” section for details.</p>
2.0.0	Reserved	Reserved	RW	0
MMD Address 2h, Register 1h – Strap Status				
2.1.15:8	Reserved	Reserved	RO	0000_0000

Address	Name	Description	Mode ⁽¹⁾	Default
2.1.7	LED_MODE Strap-In Status	Strap to 1 = Single-LED mode 0 = Bi-color dual-LED mode	RO	Set by LED_MODE strapping pin. See the “ Strapping Options ” section for details.
2.1.6	Reserved	Reserved	RO	0
2.1.5	CLK125_EN Strap-In Status	Strap to 1 = CLK125_EN strap-in is enabled 0 = CLK125_EN strap-in is disabled	RO	Set by CLK125_EN strapping pin. See the “ Strapping Options ” section for details.
2.1.4:3	Reserved	Reserved	RO	00
2.1.2:0	PHYAD[2:0] Strap-In Value	Strap-in value for PHY address Bits [4:3] of PHY address are always set to ‘00’.	RO	Set by PHYAD[2:0] strapping pin. See the “ Strapping Options ” section for details.
MMD Address 2h, Register 2h – Operation Mode Strap Override				
2.2.15:11	Reserved	Reserved	RW	0000_0
2.2.10	PME_N2 Output Enable	For INT_N/PME_N2 (pin 53), 1 = Enable PME output 0 = Disable PME output This bit works in conjunction with MMD Address 2h, Reg. 10h, Bits [15:14] to define the output for pin 53.	RW	0
2.2.9	Reserved	Reserved	RW	0
2.2.8	PME_N1 Output Enable	For LED1/PME_N1 (pin 19), 1 = Enable PME output 0 = Disable PME output This bit works in conjunction with MMD Address 2h, Reg. 10h, Bits [15:14] to define the output for pin 19.	RW	0
2.2.7	Chip Power-Down Override	1 = Override strap-in for chip power-down mode	RW	Set by MODE[3:0] strapping pin. See the “ Strapping Options ” section for details.
2.2.6:5	Reserved	Reserved	RW	00
2.2.4	NAND Tree Override	1 = Override strap-in for NAND Tree mode	RW	Set by MODE[3:0] strapping pin. See the “ Strapping Options ” section for details.
2.2.3:2	Reserved	Reserved	RW	00
2.2.1	GMII/MII override	1 = Override strap-in for GMII/MII mode	RW	Set by MODE[3:0] strapping pin. See the “ Strapping Options ” section for details.
2.2.0	Reserved	Reserved	RW	0
MMD Address 2h, Register 3h – Operation Mode Strap Status				
2.3.15:8	Reserved	Reserved	RO	0000_0000
2.3.7	Chip Power-Down Strap-In Status	1 = Strap to chip power-down mode	RO	Set by MODE[3:0] strapping pin. See the “ Strapping Options ” section for details.
2.3.6:5	Reserved	Reserved	RO	00

Address	Name	Description	Mode ⁽¹⁾	Default
2.3.4	NAND Tree Strap-In Status	1 = Strap to NAND Tree mode	RO	Set by MODE[3:0] strapping pin. See the “ Strapping Options ” section for details.
2.3.3:2	Reserved	Reserved	RO	00
2.3.1	GMII/MII Strap-In Status	1 = Strap to GMII/MII mode	RO	Set by MODE[3:0] strapping pin. See the “ Strapping Options ” section for details.
2.3.0	Reserved	Reserved	RO	0
MMD Address 2h, Register 4h – GMII Control Signal Pad Skew				
2.4.15:8	Reserved	Reserved	RW	0000_0000
2.4.7:4	RX_DV Pad Skew	GMII RX_DV output pad skew control (0.06ns/step)	RW	0111
2.4.3:0	TX_EN Pad Skew	GMII TX_EN input pad skew control (0.06ns/step)	RW	0111
MMD Address 2h, Register 8h – GMII Clock Pad Skew				
2.8.15:10	Reserved	Reserved	RW	0000_00
2.8.9:5	GTX_CLK Pad Skew	GMII GTX_CLK input pad skew control (0.06ns/step)	RW	01_111
2.8.4:0	RX_CLK Pad Skew	GMII RX_CLK output pad skew control (0.06ns/step)	RW	0_1111
MMD Address 2h, Register 10h – Wake-On-LAN – Control				
2.10.15:14	PME Output Select	These two bits work in conjunction with MMD Address 2h, Reg. 2h, Bits [8] and [10] for PME_N1 and PME_N2 enable, to define the output for pins 19 and 53, respectively. LED1/PME_N1 (pin 19) 00 = PME_N1 output only 01 = LED1 output only 10 = LED1 and PME_N1 output 11 = Reserved INT_N/PME_N2 (pin 53) 00 = PME_N2 output only 01 = INT_N output only 10 = INT_N and PME_N2 output 11 = Reserved	RW	00
2.10.13:7	Reserved	Reserved	RW	00_0000_0
2.10.6	Magic Packet Detect Enable	1 = Enable magic-packet detection 0 = Disable magic-packet detection	RW	0
2.10.5	Custom-Packet Type 3 Detect Enable	1 = Enable custom-packet, Type 3 detection 0 = Disable custom-packet, Type 3 detection	RW	0
2.10.4	Custom-Packet Type 2 Detect Enable	1 = Enable custom-packet, Type 2 detection 0 = Disable custom-packet, Type 2 detection	RW	0
2.10.3	Custom-Packet Type 1 Detect Enable	1 = Enable custom-packet, Type 1 detection 0 = Disable custom-packet, Type 1 detection	RW	0

Address	Name	Description	Mode ⁽¹⁾	Default
2.10.2	Custom-Packet Type 0 Detect Enable	1 = Enable custom-packet, Type 0 detection 0 = Disable custom-packet, Type 0 detection	RW	0
2.10.1	Link-Down Detect Enable	1 = Enable link-down detection 0 = Disable link-down detection	RW	0
2.10.0	Link-Up Detect Enable	1 = Enable link-up detection 0 = Disable link-up detection	RW	0
MMD Address 2h, Register 11h – Wake-On-LAN – Magic Packet, MAC-DA-0				
2.11.15:0	Magic Packet MAC-DA-0	This register stores the lower two bytes of the destination MAC address for the magic packet. Bit [15:8] = Byte 2 (MAC Address [15:8]) Bit [7:0] = Byte 1 (MAC Address [7:0]) The upper four bytes of the destination MAC address are stored in the following two registers.	RW	0000_0000_0000_0000
MMD Address 2h, Register 12h – Wake-On-LAN – Magic Packet, MAC-DA-1				
2.12.15:0	Magic Packet MAC-DA-1	This register stores the middle two bytes of the destination MAC address for the magic packet. Bit [15:8] = Byte 4 (MAC Address [31:24]) Bit [7:0] = Byte 3 (MAC Address [23:16]) The lower two bytes and upper two bytes of the destination MAC address are stored in the previous and following registers, respectively.	RW	0000_0000_0000_0000
MMD Address 2h, Register 13h – Wake-On-LAN – Magic Packet, MAC-DA-2				
2.13.15:0	Magic Packet MAC-DA-2	This register stores the upper two bytes of the destination MAC address for the magic packet. Bit [15:8] = Byte 6 (MAC Address [47:40]) Bit [7:0] = Byte 5 (MAC Address [39:32]) The lower four bytes of the destination MAC address are stored in the previous two registers.	RW	0000_0000_0000_0000
MMD Address 2h, Register 14h – Wake-On-LAN – Customized Packet, Type 0, Expected CRC 0				
MMD Address 2h, Register 16h – Wake-On-LAN – Customized Packet, Type 1, Expected CRC 0				
MMD Address 2h, Register 18h – Wake-On-LAN – Customized Packet, Type 2, Expected CRC 0				
MMD Address 2h, Register 1Ah – Wake-On-LAN – Customized Packet, Type 3, Expected CRC 0				
2.14.15:0 2.16.15:0 2.18.15:0 2.1A.15:0	Custom Packet Type X CRC 0	This register stores the lower two bytes for the expected CRC. Bit [15:8] = Byte 2 (CRC [15:8]) Bit [7:0] = Byte 1 (CRC [7:0]) The upper two bytes for the expected CRC are stored in the following register.	RW	0000_0000_0000_0000

Address	Name	Description	Mode ⁽¹⁾	Default
MMD Address 2h, Register 15h – Wake-On-LAN – Customized Packet, Type 0, Expected CRC 1 MMD Address 2h, Register 17h – Wake-On-LAN – Customized Packet, Type 1, Expected CRC 1 MMD Address 2h, Register 19h – Wake-On-LAN – Customized Packet, Type 2, Expected CRC 1 MMD Address 2h, Register 1Bh – Wake-On-LAN – Customized Packet, Type 3, Expected CRC 1				
2.15.15:0 2.17.15:0 2.19.15:0 2.1B.15:0	Custom Packet Type X CRC 1	This register stores the upper two bytes for the expected CRC. Bit [15:8] = Byte 4 (CRC [31:24]) Bit [7:0] = Byte 3 (CRC [23:16]) The lower two bytes for the expected CRC are stored in the previous register.	RW	0000_0000_0000_0000
MMD Address 2h, Register 1Ch – Wake-On-LAN – Customized Packet, Type 0, Mask 0 MMD Address 2h, Register 20h – Wake-On-LAN – Customized Packet, Type 1, Mask 0 MMD Address 2h, Register 24h – Wake-On-LAN – Customized Packet, Type 2, Mask 0 MMD Address 2h, Register 28h – Wake-On-LAN – Customized Packet, Type 3, Mask 0				
2.1C.15:0 2.20.15:0 2.24.15:0 2.28.15:0	Custom Packet Type X Mask 0	This register selects the bytes in the first 16 bytes of the packet (bytes 1 thru 16) that will be used for CRC calculation. For each bit in this register, 1 = Byte is selected for CRC calculation 0 = Byte is not selected for CRC calculation The register-bit to packet-byte mapping is as follows: Bit [15] : Byte 16 ... : ... Bit [2] : Byte 2 Bit [0] : Byte 1	RW	0000_0000_0000_0000
MMD Address 2h, Register 1Dh – Wake-On-LAN – Customized Packet, Type 0, Mask 1 MMD Address 2h, Register 21h – Wake-On-LAN – Customized Packet, Type 1, Mask 1 MMD Address 2h, Register 25h – Wake-On-LAN – Customized Packet, Type 2, Mask 1 MMD Address 2h, Register 29h – Wake-On-LAN – Customized Packet, Type 3, Mask 1				
2.1D.15:0 2.21.15:0 2.25.15:0 2.29.15:0	Custom Packet Type X Mask 1	This register selects the bytes in the second 16 bytes of the packet (bytes 17 thru 32) that will be used for CRC calculation. For each bit in this register, 1 = Byte is selected for CRC calculation 0 = Byte is not selected for CRC calculation The register-bit to packet-byte mapping is as follows: Bit [15] : Byte 32 ... : ... Bit [2] : Byte 18 Bit [0] : Byte 17	RW	0000_0000_0000_0000

Address	Name	Description	Mode ⁽¹⁾	Default
MMD Address 2h, Register 1Eh – Wake-On-LAN – Customized Packet, Type 0, Mask 2				
MMD Address 2h, Register 22h – Wake-On-LAN – Customized Packet, Type 1, Mask 2				
MMD Address 2h, Register 26h – Wake-On-LAN – Customized Packet, Type 2, Mask 2				
MMD Address 2h, Register 2Ah – Wake-On-LAN – Customized Packet, Type 3, Mask 2				
2.1E.15:0 2.22.15:0 2.26.15:0 2.2A.15:0	Custom Packet Type X Mask 2	This register selects the bytes in the third 16 bytes of the packet (bytes 33 thru 48) that will be used for CRC calculation. For each bit in this register, 1 = Byte is selected for CRC calculation 0 = Byte is not selected for CRC calculation The register-bit to packet-byte mapping is as follows: Bit [15] : Byte 48 ... : ... Bit [2] : Byte 34 Bit [0] : Byte 33	RW	0000_0000_0000_0000
MMD Address 2h, Register 1Fh – Wake-On-LAN – Customized Packet, Type 0, Mask 3				
MMD Address 2h, Register 23h – Wake-On-LAN – Customized Packet, Type 1, Mask 3				
MMD Address 2h, Register 27h – Wake-On-LAN – Customized Packet, Type 2, Mask 3				
MMD Address 2h, Register 2Bh – Wake-On-LAN – Customized Packet, Type 3, Mask 3				
2.1F.15:0 2.23.15:0 2.27.15:0 2.2B.15:0	Custom Packet Type X Mask 3	This register selects the bytes in the fourth 16 bytes of the packet (bytes 49 thru 64) that will be used for CRC calculation. For each bit in this register, 1 = Byte is selected for CRC calculation 0 = Byte is not selected for CRC calculation The register-bit to packet-byte mapping is as follows: Bit [15] : Byte 64 ... : ... Bit [2] : Byte 50 Bit [0] : Byte 49	RW	0000_0000_0000_0000
MMD Address 3h, Register 0h – PCS EEE – Control				
3.0.15:12	Reserved	Reserved	RW	0000
3.0.11	1000Base-T Force LPI	1 = Force 1000Base-T low-power idle transmission 0 = Normal operation	RW	0
3.0.10	100Base-TX RX_CLK Stoppable	During receive lower-power idle mode, 1 = RX_CLK stoppable for 100Base-TX 0 = RX_CLK not stoppable for 100Base-TX	RW	0
3.0.9:0	Reserved	Reserved	RW	00_0000_0000
MMD Address 3h, Register 1h – PCS EEE – Status				
3.1.15:12	Reserved	Reserved	RO	0000

Address	Name	Description	Mode ⁽¹⁾	Default
3.1.11	Transmit Low-Power Idle Received	1 = Transmit PCS has received low-power idle 0 = Low-power idle not received	RO/LH	0
3.1.10	Receive Low-Power Idle Received	1 = Receive PCS has received low-power idle 0 = Low-power idle not received	RO/LH	0
3.1.9	Transmit Low-Power Idle Indication	1 = Transmit PCS is currently receiving low-power idle 0 = Transmit PCS is not currently receiving low-power idle	RO	
3.1.8	Receive Low-Power Idle Indication	1 = Receive PCS is currently receiving low-power idle 0 = Receive PCS is not currently receiving low-power idle	RO	
3.1.7:0	Reserved	Reserved	RO	0000_0000
MMD Address 7h, Register 3Ch – EEE Advertisement				
7.3C.15:3	Reserved	Reserved	RW	0000_0000_0000_0
7.3C.2	1000Base-T EEE	1 = 1000Mbps EEE capable 0 = No 1000Mbps EEE capability This bit is set to '0' as the default after power-up or reset. Set this bit to '1' to enable 1000Mbps EEE mode.	RW	0
7.3C.1	100Base-TX EEE	1 = 100Mbps EEE capable 0 = No 100Mbps EEE capability This bit is set to '0' as the default after power-up or reset. Set this bit to '1' to enable 100Mbps EEE mode.	RW	0
7.3C.0	Reserved	Reserved	RW	0
MMD Address 7h, Register 3Dh – EEE Link Partner Advertisement				
7.3D.15:3	Reserved	Reserved	RO	0000_0000_0000_0
7.3D.2	1000Base-T EEE	1 = 1000Mbps EEE capable 0 = No 1000Mbps EEE capability	RO	0
7.3D.1	100Base-TX EEE	1 = 100Mbps EEE capable 0 = No 100Mbps EEE capability	RO	0
7.3D.0	Reserved	Reserved	RO	0
MMD Address 1Ch, Register 4h – Analog Control 4				
1C.4.15:11	Reserved	Reserved	RW	0000_0
1C.4.10	10Base-Te Mode	1 = EEE 10Base-Te (1.75V TX amplitude) 0 = Standard 10Base-T (2.5V TX amplitude)	RW	0
1C.4.9:0	Reserved	Reserved	RW	00_1111_1111

Address	Name	Description	Mode ⁽¹⁾	Default
MMD Address 1Ch, Register 23h – EDPD Control				
1C.23.15:1	Reserved	Reserved	RW	0000_0000_0000_000
1C.23.0	EDPD Mode Enable	Energy-detect power-down mode 1 = Enable 0 = Disable	RW	0

Note:

1. RW = Read/Write.
RO = Read only.
LH = Latch high.

Absolute Maximum Ratings⁽¹⁾

Supply Voltage (V_{IN})	
(DVDDL, AVDDL, AVDDL_PLL)	-0.5V to +1.8V
(AVDDH)	-0.5V to +5.0V
(DVDDH)	-0.5V to +5.0V
Input Voltage (all inputs)	-0.5V to +5.0V
Output Voltage (all outputs)	-0.5V to +5.0V
Lead Temperature (soldering, 10sec.)	260°C
Storage Temperature (T_s)	-55°C to +150°C

Operating Ratings⁽²⁾

Supply Voltage	
(DVDDL, AVDDL, AVDDL_PLL)	+1.140V to +1.260V
(AVDDH @ 3.3V)	+3.135V to +3.465V
(AVDDH @ 2.5V, C-temp only)	+2.375V to +2.625V
(DVDDH @ 3.3V)	+3.135V to +3.465V
(DVDDH @ 2.5V)	+2.375V to +2.625V
(DVDDH @ 1.8V)	+1.710V to +1.890V
Ambient Temperature	
(T_A Commercial: KSZ9031MNXC)	0°C to +70°C
(T_A Industrial: KSZ9031MNXI)	-40°C to +85°C
Maximum Junction Temperature (T_J Max)	125°C
Thermal Resistance (θ_{JA})	32.27°C/W
Thermal Resistance (θ_{JC})	6.76°C/W

Electrical Characteristics⁽³⁾

Symbol	Parameter	Condition	Min.	Typ.	Max.	Units
Supply Current – Core / Digital I/Os						
I_{CORE}	1.2V Total of: DVDDL (digital core) + AVDDL (analog core) + AVDDL_PLL (PLL)	1000Base-T link-up (no traffic)		211		mA
		1000Base-T full-duplex @ 100% utilization		221		mA
		100Base-TX link-up (no traffic)		60.6		mA
		100Base-TX full-duplex @ 100% utilization		61.2		mA
		10Base-T link-up (no traffic)		7.0		mA
		10Base-T full-duplex @ 100% utilization		7.7		mA
		Software power-down mode (Reg. 0.11 = 1)		0.9		mA
		Chip power-down mode (strap-in pins MODE[3:0] = 0111)		0.8		mA
$I_{DVDDH_1.8}$	1.8V for Digital I/Os (GMII/MII operating @ 1.8V)	1000Base-T link-up (no traffic)		14.2		mA
		1000Base-T full-duplex @ 100% utilization		29.3		mA
		100Base-TX link-up (no traffic)		7.3		mA
		100Base-TX full-duplex @ 100% utilization		10.0		mA
		10Base-T link-up (no traffic)		3.1		mA
		10Base-T full-duplex @ 100% utilization		6.0		mA
		Software power-down mode (Reg. 0.11 = 1)		3.7		mA
		Chip power-down mode (strap-in pins MODE[3:0] = 0111)		0.2		mA

Notes:

- Exceeding the absolute maximum rating can damage the device. Stresses greater than the absolute maximum rating can cause permanent damage to the device. Operation of the device at these or any other conditions above those specified in the operating sections of this specification is not implied. Maximum conditions for extended periods may affect reliability.
- The device is not guaranteed to function outside its operating rating.
- $T_A = 25^\circ\text{C}$. Specification is for packaged product only.

Symbol	Parameter	Condition	Min.	Typ.	Max.	Units
I _{DVDDH_2.5}	2.5V for Digital I/Os (GMII/MII operating @ 2.5V)	1000Base-T link-up (no traffic)		19.3		mA
		1000Base-T full-duplex @ 100% utilization		40.5		mA
		100Base-TX link-up (no traffic)		10.0		mA
		100Base-TX full-duplex @ 100% utilization		13.7		mA
		10Base-T link-up (no traffic)		4.3		mA
		10Base-T full-duplex @ 100% utilization		8.3		mA
		Software power-down mode (Reg. 0.11 = 1)		5.3		mA
		Chip power-down mode (strap-in pins MODE[3:0] = 0111)		0.9		mA
I _{DVDDH_3.3}	3.3V for Digital I/Os (GMII/MII operating @ 3.3V)	1000Base-T link-up (no traffic)		26.0		mA
		1000Base-T full-duplex @ 100% utilization		53.8		mA
		100Base-TX link-up (no traffic)		13.3		mA
		100Base-TX full-duplex @ 100% utilization		18.0		mA
		10Base-T link-up (no traffic)		5.7		mA
		10Base-T full-duplex @ 100% utilization		11.1		mA
		Software power-down mode (Reg. 0.11 = 1)		7.1		mA
		Chip power-down mode (strap-in pins MODE[3:0] = 0111)		2.1		mA
Supply Current – Transceiver (equivalent to current draw through external transformer center taps for PHY transceivers with current-mode transmit drivers)						
I _{AVDDH_2.5}	2.5V for Transceiver (Recommended for commercial temperature range operation only)	1000Base-T link-up (no traffic)		58.6		mA
		1000Base-T full-duplex @ 100% utilization		57.6		mA
		100Base-TX link-up (no traffic)		24.8		mA
		100Base-TX full-duplex @ 100% utilization		24.8		mA
		10Base-T link-up (no traffic)		12.5		mA
		10Base-T full-duplex @ 100% utilization		25.8		mA
		Software power-down mode (Reg. 0h, bit 11 = 1)		3.0		mA
		Chip power-down mode (strap-in pins MODE[3:0] = 0111)		0.02		mA
I _{AVDDH_3.3}	3.3V for Transceiver	1000Base-T link-up (no traffic)		66.6		mA
		1000Base-T full-duplex @ 100% utilization		65.6		mA
		100Base-TX link-up (no traffic)		28.7		mA
		100Base-TX full-duplex @ 100% utilization		28.7		mA
		10Base-T link-up (no traffic)		17.0		mA
		10Base-T full-duplex @ 100% utilization		29.3		mA
		Software power-down mode (Reg. 0h, bit 11 = 1)		4.1		mA
		Chip power-down mode (strap-in pins MODE[3:0] = 0111)		0.02		mA
CMOS Inputs						
V _{IH}	Input High Voltage	DVDDH (digital I/Os) = 3.3V	2.0			V
		DVDDH (digital I/Os) = 2.5V	1.5			V
		DVDDH (digital I/Os) = 1.8V	1.1			V

Symbol	Parameter	Condition	Min.	Typ.	Max.	Units
V _{IL}	Input Low Voltage	DVDDH (digital I/Os) = 3.3V			1.3	V
		DVDDH (digital I/Os) = 2.5V			1.0	V
		DVDDH (digital I/Os) = 1.8V			0.7	V
I _{IN}	Input Current	V _{IN} = GND ~ V _{DDIO}			10	μA
CMOS Outputs						
V _{OH}	Output High Voltage	DVDDH (digital I/Os) = 3.3V	2.7			V
		DVDDH (digital I/Os) = 2.5V	2.0			V
		DVDDH (digital I/Os) = 1.8V	1.5			V
V _{OL}	Output Low Voltage	DVDDH (digital I/Os) = 3.3V			0.3	V
		DVDDH (digital I/Os) = 2.5V			0.3	V
		DVDDH (digital I/Os) = 1.8V			0.3	V
I _{oz}	Output Tri-State Leakage				10	μA
LED Outputs						
I _{LED}	Output Drive Current	Each LED pin (LED1, LED2)		8		mA
Pull-Up Pins						
p _u	Internal Pull-Up Resistance (MDC, MDIO, RESET_N pins)	DVDDH (digital I/Os) = 3.3V	13	22	31	kΩ
		DVDDH (digital I/Os) = 2.5V	16	28	39	kΩ
		DVDDH (digital I/Os) = 1.8V	26	44	62	kΩ
100Base-TX Transmit (measured differentially after 1:1 transformer)						
V _O	Peak Differential Output Voltage	100Ω termination across differential output	0.95		1.05	V
V _{IMB}	Output Voltage Imbalance	100Ω termination across differential output			2	%
t _r , t _f	Rise/Fall Time		3		5	ns
	Rise/Fall Time Imbalance		0		0.5	ns
	Duty Cycle Distortion				±0.25	ns
	Overshoot				5	%
	Output Jitter	Peak-to-peak		0.7		ns
10Base-T Transmit (measured differentially after 1:1 transformer)						
V _P	Peak Differential Output Voltage	100Ω termination across differential output	2.2		2.8	V
	Jitter Added	Peak-to-peak			3.5	ns
	Harmonic Rejection	Transmit all-one signal sequence		-31		dB
10Base-T Receive						
V _{SQ}	Squelch Threshold	5MHz square wave	300	400		mV
Transmitter – Drive Setting						
V _{SET}	Reference Voltage of I _{SET}	R(I _{SET}) = 12.1kΩ		1.2		V
LDO Controller – Drive Range						
V _{LDO_O}	Output drive range for LDO_O (pin 58) to gate input of P-channel MOSFET	AVDDH = 3.3V for MOSFET source voltage	0.85		2.8	V
		AVDDH = 2.5V for MOSFET source voltage (recommended for commercial temperature range operation only)	0.85		2.0	V

Timing Diagrams

GMII Transmit Timing

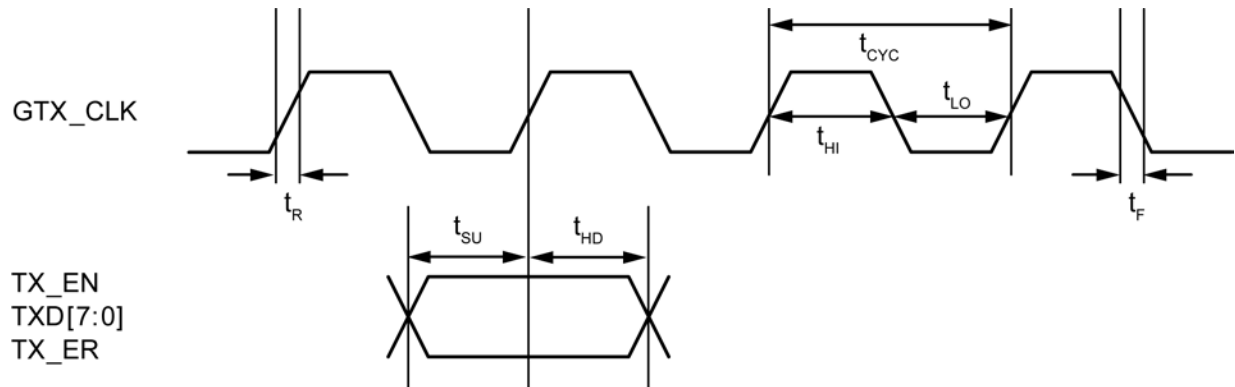

Figure 13. GMII Transmit Timing – Data Input to PHY

Timing Parameter	Description	Min.	Typ.	Max.	Unit
1000Base-T					
t_{CYC}	GTX_CLK period	7.5	8.0	8.5	ns
t_{SU}	TX_EN, TXD[7:0], TX_ER setup time to rising edge of GTX_CLK	2.0			ns
t_{HD}	TX_EN, TXD[7:0], TX_ER hold time from rising edge of GTX_CLK	0			ns
t_{HI}	GTX_CLK high pulse width	2.5			ns
t_{LO}	GTX_CLK low pulse width	2.5			ns
t_R	GTX_CLK rise time			1.0	ns
t_F	GTX_CLK fall time			1.0	ns

Table 16. GMII Transmit Timing Parameters

GMII Receive Timing

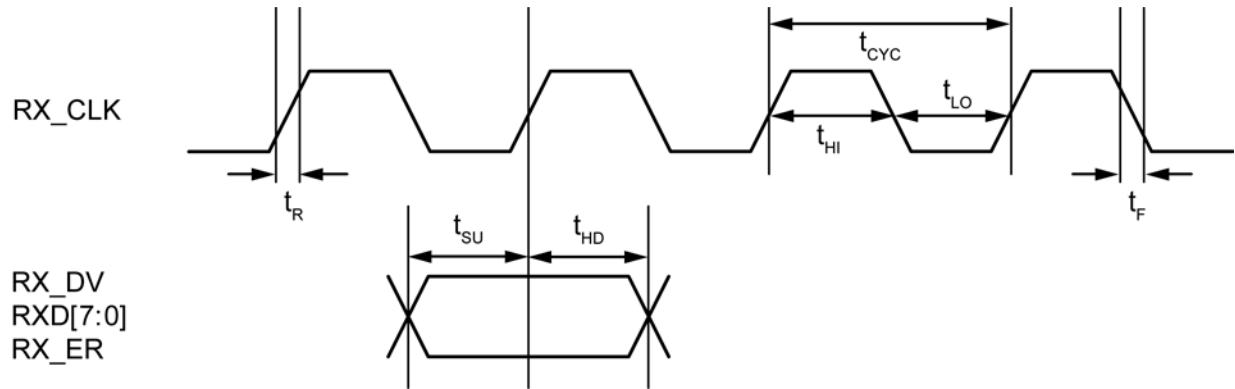

Figure 14. GMII Receive Timing – Data Input to MAC

Timing Parameter	Description	Min.	Typ.	Max.	Unit
1000Base-T					
t_{CYC}	RX_CLK period	7.5	8.0	8.5	ns
t_{SU}	RX_DV, RXD[7:0], RX_ER setup time to rising edge of RX_CLK	2.5			ns
t_{HD}	RX_DV, RXD[7:0], RX_ER hold time from rising edge of RX_CLK	0.5			ns
t_{HI}	RX_CLK high pulse width	2.5			ns
t_{LO}	RX_CLK low pulse width	2.5			ns
t_R	RX_CLK rise time			1.0	ns
t_F	RX_CLK fall time			1.0	ns

Table 17. GMII Receive Timing Parameters

MII Transmit Timing

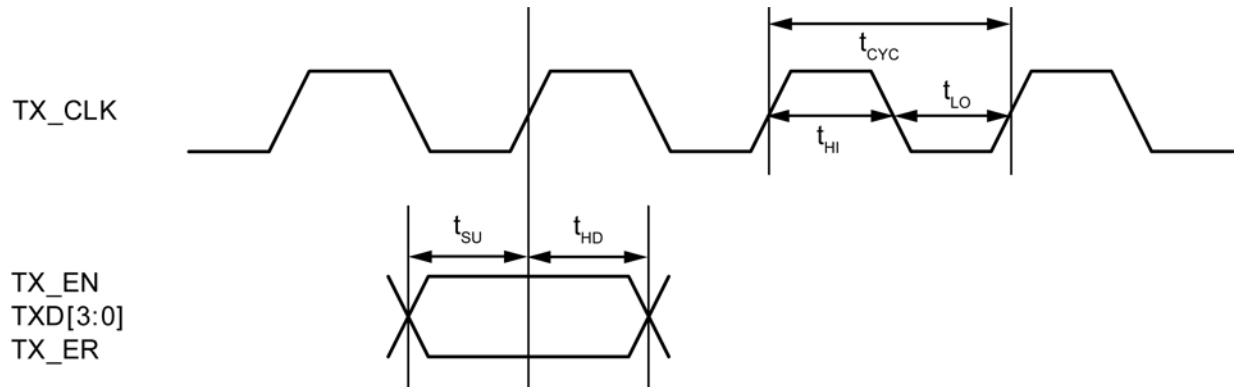

Figure 15. MII Transmit Timing – Data Input to PHY

Timing Parameter	Description	Min.	Typ.	Max.	Unit
10Base-T					
t_{CYC}	TX_CLK period		400		ns
t_{SU}	TX_EN, TXD[3:0], TX_ER setup time to rising edge of TX_CLK	15			ns
t_{HD}	TX_EN, TXD[3:0], TX_ER hold time from rising edge of TX_CLK	0			ns
t_{HI}	TX_CLK high pulse width	140		260	ns
t_{LO}	TX_CLK low pulse width	140		260	ns
100Base-TX					
t_{CYC}	TX_CLK period		40		ns
t_{SU}	TX_EN, TXD[3:0], TX_ER setup time to rising edge of TX_CLK	15			ns
t_{HD}	TX_EN, TXD[3:0], TX_ER hold time from rising edge of TX_CLK	0			ns
t_{HI}	TX_CLK high pulse width	14		26	ns
t_{LO}	TX_CLK low pulse width	14		26	ns

Table 18. MII Transmit Timing Parameters

MII Receive Timing

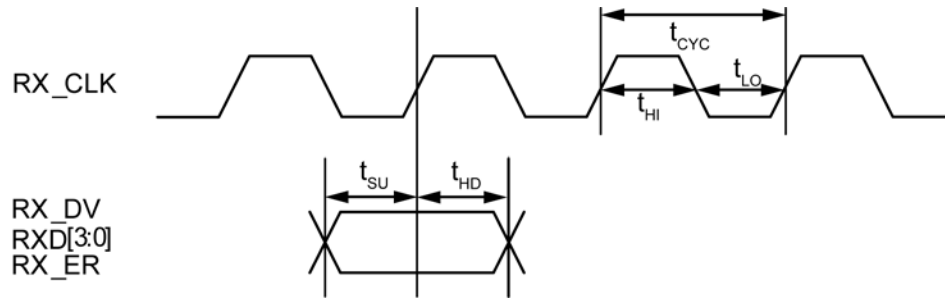

Figure 16. MII Receive Timing – Data Input to MAC

Timing Parameter	Description	Min.	Typ.	Max.	Unit
10Base-T					
t_{CYC}	RX_CLK period		400		ns
t_{SU}	RX_DV, RXD[3:0], RX_ER setup time to rising edge of RX_CLK	10			ns
t_{HD}	RX_DV, RXD[3:0], RX_ER hold time from rising edge of RX_CLK	10			ns
t_{HI}	RX_CLK high pulse width	140		260	ns
t_{LO}	RX_CLK low pulse width	140		260	ns
100Base-TX					
t_{CYC}	RX_CLK period		40		ns
t_{SU}	RX_DV, RXD[3:0], RX_ER setup time to rising edge of RX_CLK	10			ns
t_{HD}	RX_DV, RXD[3:0], RX_ER hold time from rising edge of RX_CLK	10			ns
t_{HI}	RX_CLK high pulse width	14		26	ns
t_{LO}	RX_CLK low pulse width	14		26	ns

Table 19. MII Receive Timing Parameters

Auto-Negotiation Timing

AUTO-NEGOTIATION FAST LINK PULSE (FLP) TIMING

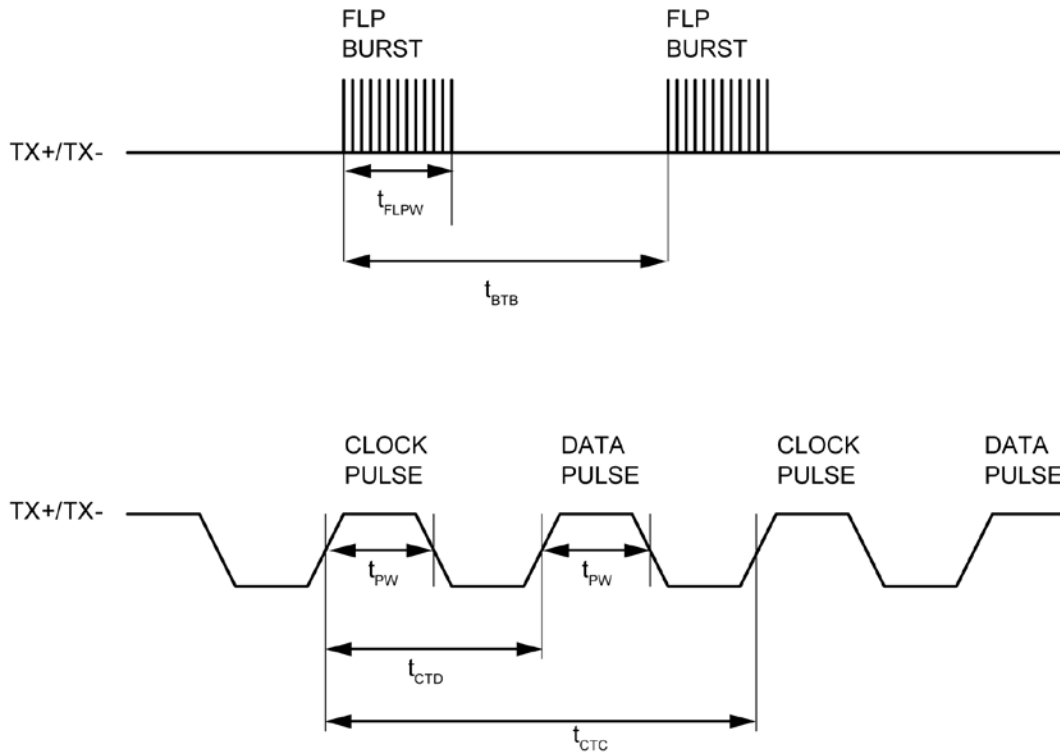

Figure 17. Auto-Negotiation Fast Link Pulse (FLP) Timing

Timing Parameter	Description	Min.	Typ.	Max.	Units
t_{BTB}	FLP burst to FLP burst	8	16	24	ms
t_{FLPW}	FLP burst width		2		ms
t_{PW}	Clock/Data pulse width		100		ns
t_{CTD}	Clock pulse to data pulse	55.5	64	69.5	μ s
t_{CTC}	Clock pulse to clock pulse	111	128	139	μ s
	Number of clock/data pulses per FLP burst	17		33	

Table 20. Auto-Negotiation Fast Link Pulse (FLP) Timing Parameters

MDC/MDIO Timing

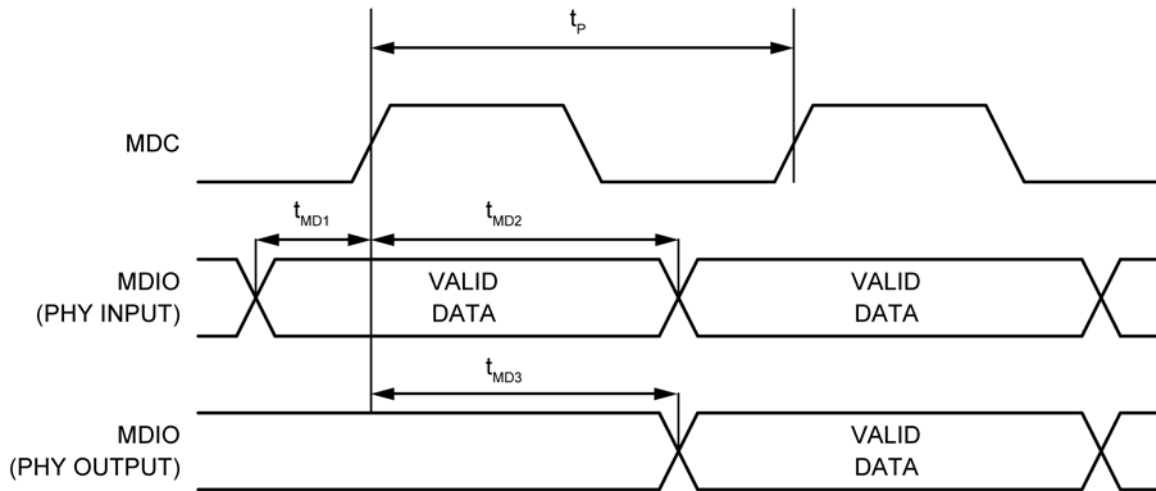

Figure 18. MDC/MDIO Timing

Timing Parameter	Description	Min.	Typ.	Max.	Unit
t_P	MDC period		400		ns
t_{1MD1}	MDIO (PHY input) setup to rising edge of MDC	10			ns
t_{MD2}	MDIO (PHY input) hold from rising edge of MDC	10			ns
t_{MD3}	MDIO (PHY output) delay from rising edge of MDC	0			ns

Table 21. MDC/MDIO Timing Parameters

Power-Up/Power-Down/Reset Timing

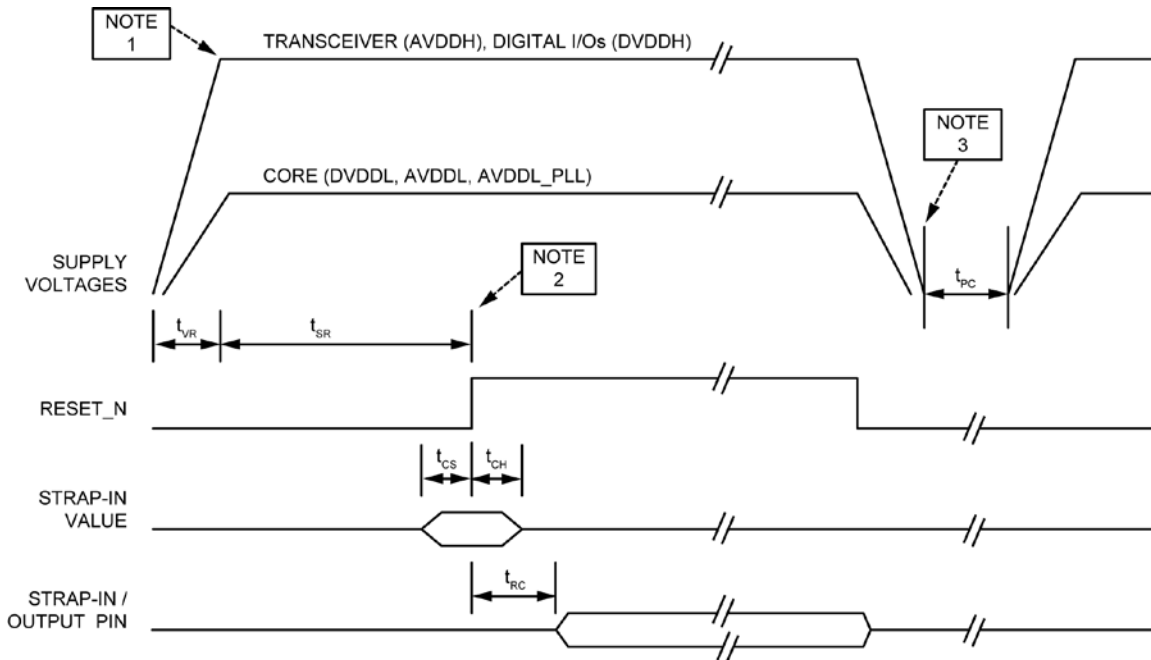

Figure 19. Power-Up/Power-Down/Reset Timing

Parameter	Description	Min.	Max.	Units
t_{vr}	Supply voltages rise time (must be monotonic)	200		μ s
t_{sr}	Stable supply voltages to de-assertion of reset	10		ms
t_{cs}	Strap-in pin configuration setup time	5		ns
t_{ch}	Strap-in pin configuration hold time	5		ns
t_{rc}	De-assertion of reset to strap-in pin output	6		ns
t_{pc}	Supply voltages cycle off-to-on time	150		ms

Table 22. Power-Up/Power-Down/Reset Timing Parameters

NOTE 1: The recommended power-up sequence is to have the transceiver (AVDDH) and digital I/O (DVDDH) voltages power up before the 1.2V core (DVDDL, AVDDL, AVDDL_PLL) voltage. If the 1.2V core must power up first, the maximum lead time for the 1.2V core voltage with respect to the transceiver and digital I/O voltages should be 200 μ s.

There is no power sequence requirement between transceiver (AVDDH) and digital I/O (DVDDH) power rails.

The power-up waveforms should be monotonic for all supply voltages to the KSZ9031MNX.

NOTE 2: After the de-assertion of reset, wait a minimum of 100 μ s before starting programming on the MIIM (MDC/MDIO) interface.

NOTE 3: The recommended power-down sequence is to have the 1.2V core voltage power down before powering down the transceiver and digital I/O voltages.

Before the next power-up cycle, all supply voltages to the KSZ9031MNX should reach 0V and there should be a minimum wait time of 150ms from power-off to power-on.

Reset Circuit

The following reset circuit is recommended for powering up the KSZ9031MNX if reset is triggered by the power supply.

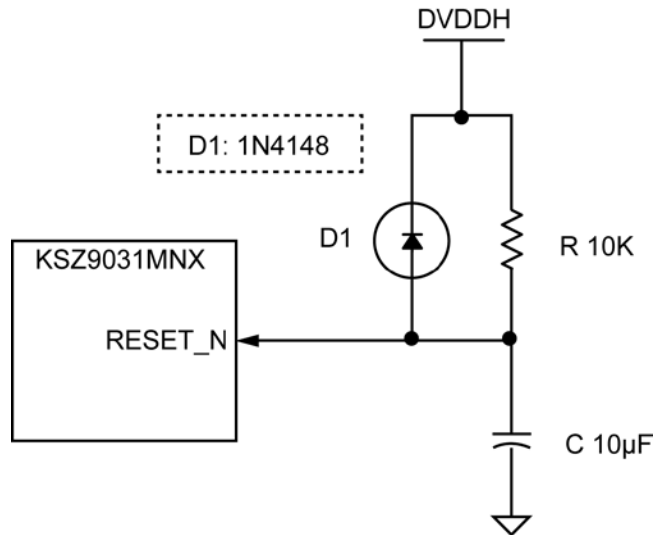

Figure 20. Recommended Reset Circuit

The following reset circuit is recommended for applications where reset is driven by another device (for example, the CPU or an FPGA). At power-on-reset, R, C, and D1 provide the necessary ramp rise time to reset the KSZ9031MNX device. The RST_OUT_N from the CPU/FPGA provides the warm reset after power-up.

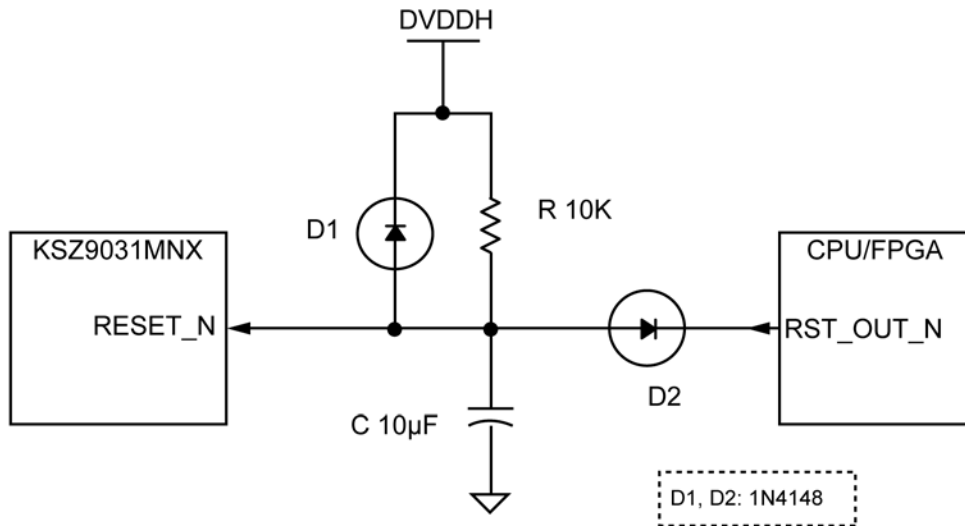

Figure 21. Recommended Reset Circuit for Interfacing with CPU/FPGA Reset Output

Reference Circuits – LED Strap-In Pins

The pull-up and pull-down reference circuits for the LED2/PHYAD1 and LED1/PHYAD0 strapping pins are shown in [Figure 22](#) for 3.3V and 2.5V DVDDH.

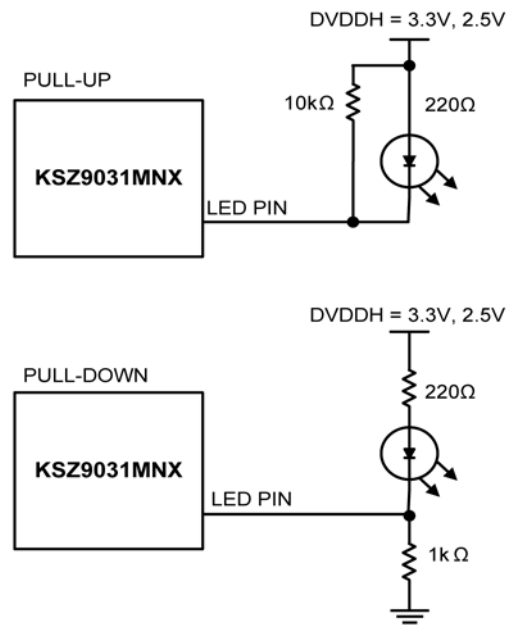

Figure 22. Reference Circuits for LED Strapping Pins

For 1.8V DVDDH, LED indication support is not recommended due to the low voltage. Without the LED indicator, the PHYAD1 and PHYAD0 strapping pins are functional with 10kΩ pull-up to 1.8V DVDDH for a value of 1, and with 1.0kΩ pull-down to ground for a value of 0.

Reference Clock – Connection and Selection

A crystal or external clock source, such as an oscillator, is used to provide the reference clock for the KSZ9031MNX. The reference clock is 25MHz for all operating modes of the KSZ9031MNX.

Figure 23 and Table 23 shows the reference clock connection to XI (pin 61) and XO (pin 60) of the KSZ9031MNX, and the reference clock selection criteria.

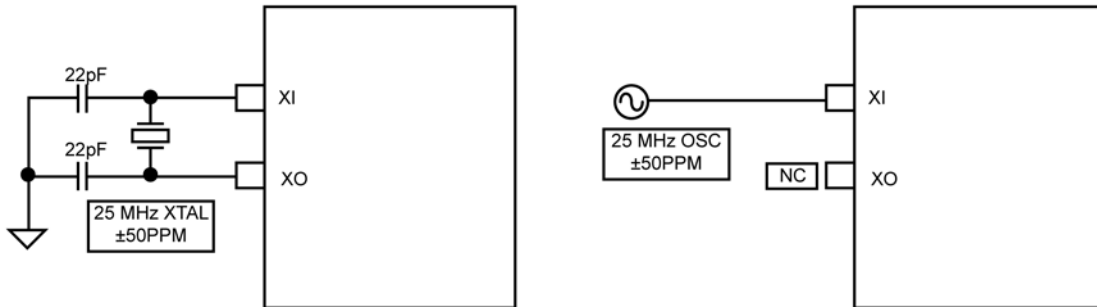

Figure 23. 25MHz Crystal/Oscillator Reference Clock Connection

Characteristics	Value	Units
Frequency	25	MHz
Frequency tolerance (max)	±50	ppm

Table 23. Reference Crystal/Clock Selection Criteria

Magnetic – Connection and Selection

A 1:1 isolation transformer is required at the line interface. Use one with integrated common-mode chokes for designs exceeding FCC requirements. An optional auto-transformer stage following the chokes provides additional common-mode noise and signal attenuation.

The KSZ9031MNX design incorporates voltage-mode transmit drivers and on-chip terminations.

With the voltage-mode implementation, the transmit drivers supply the common-mode voltages to the four differential pairs. Therefore, the four transformer center tap pins on the KSZ9031MNX side should not be connected to any power supply source on the board; rather, the center tap pins should be separated from one another and connected through separate 0.1µF common-mode capacitors to ground. Separation is required because the common-mode voltage could be different between the four differential pairs, depending on the connected speed mode.

Figure 24 shows the typical gigabit magnetic interface circuit for the KSZ9031MNX.

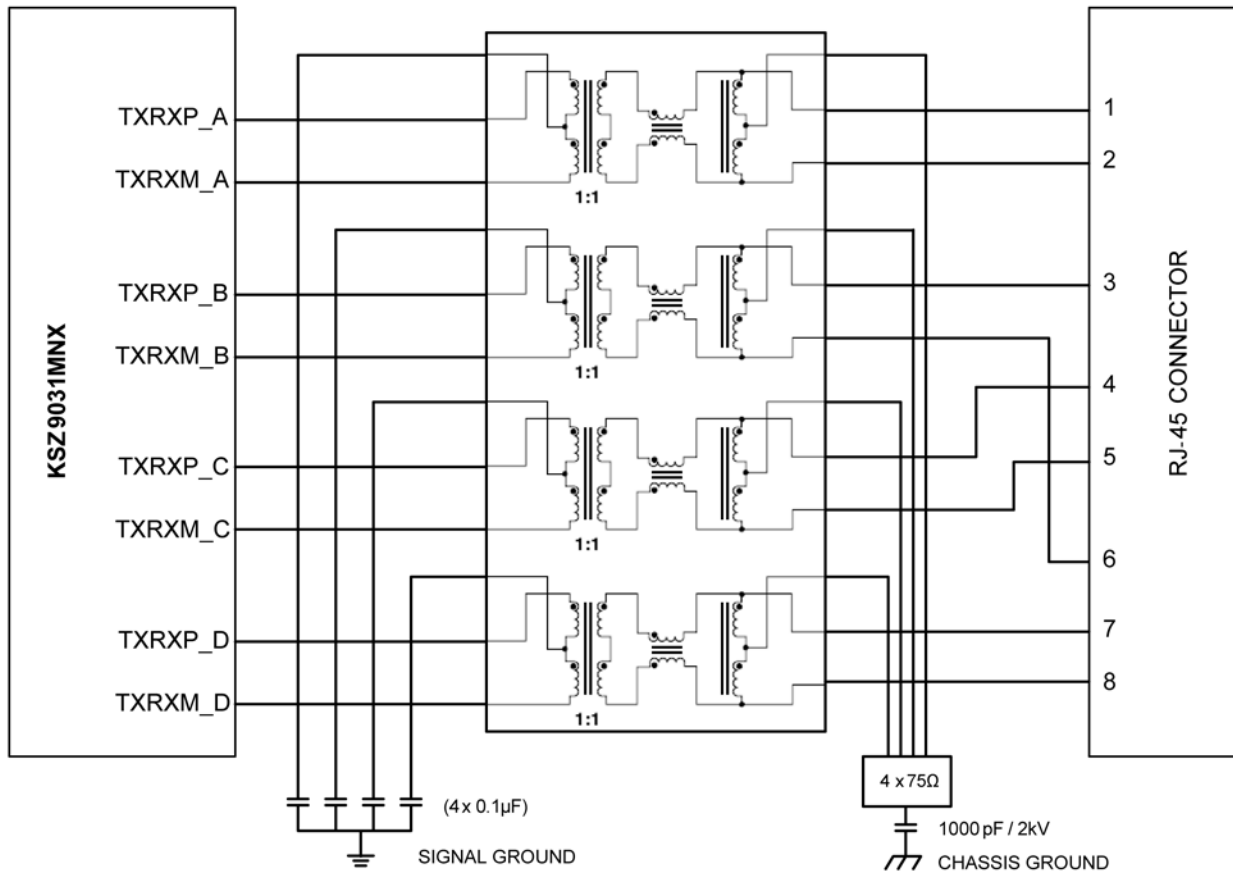

Figure 24. Typical Gigabit Magnetic Interface Circuit

Table 24 lists recommended magnetic characteristics.

Parameter	Value	Test Condition
Turns ratio	1 CT : 1 CT	
Open-circuit inductance (min.)	350 μ H	100mV, 100kHz, 8mA
Insertion loss (max.)	1.0dB	0MHz to 100MHz
HIPOT (min.)	1500Vrms	

Table 24. Magnetics Selection Criteria

Table 25 is a list of compatible single-port magnetics with separated transformer center tap pins on the G-PHY chip side that can be used with the KSZ9031MNX.

Manufacturer	Part Number	Auto-Transformer	Temperature Range	Magnetic + RJ-45
Bel Fuse	0826-1G1T-23-F	Yes	0°C to 70°C	Yes
HALO	TG1G-E001NZRL	No	-40°C to 85°C	No
HALO	TG1G-S001NZRL	No	0°C to 70°C	No
HALO	TG1G-S002NZRL	Yes	0°C to 70°C	No
Pulse	H5007NL	Yes	0°C to 70°C	No
Pulse	H5062NL	Yes	0°C to 70°C	No
Pulse	HX5008NL	Yes	-40°C to 85°C	No
Pulse	JK0654219NL	Yes	0°C to 70°C	Yes
Pulse	JK0-0136NL	No	0°C to 70°C	Yes
TDK	TLA-7T101LF	No	0°C to 70°C	No
Würth/Midcom	000-7093-37R-LF1	Yes	0°C to 70°C	No

Table 25. Compatible Single-Port 10/100/1000 Magnetics

Recommended Land Pattern

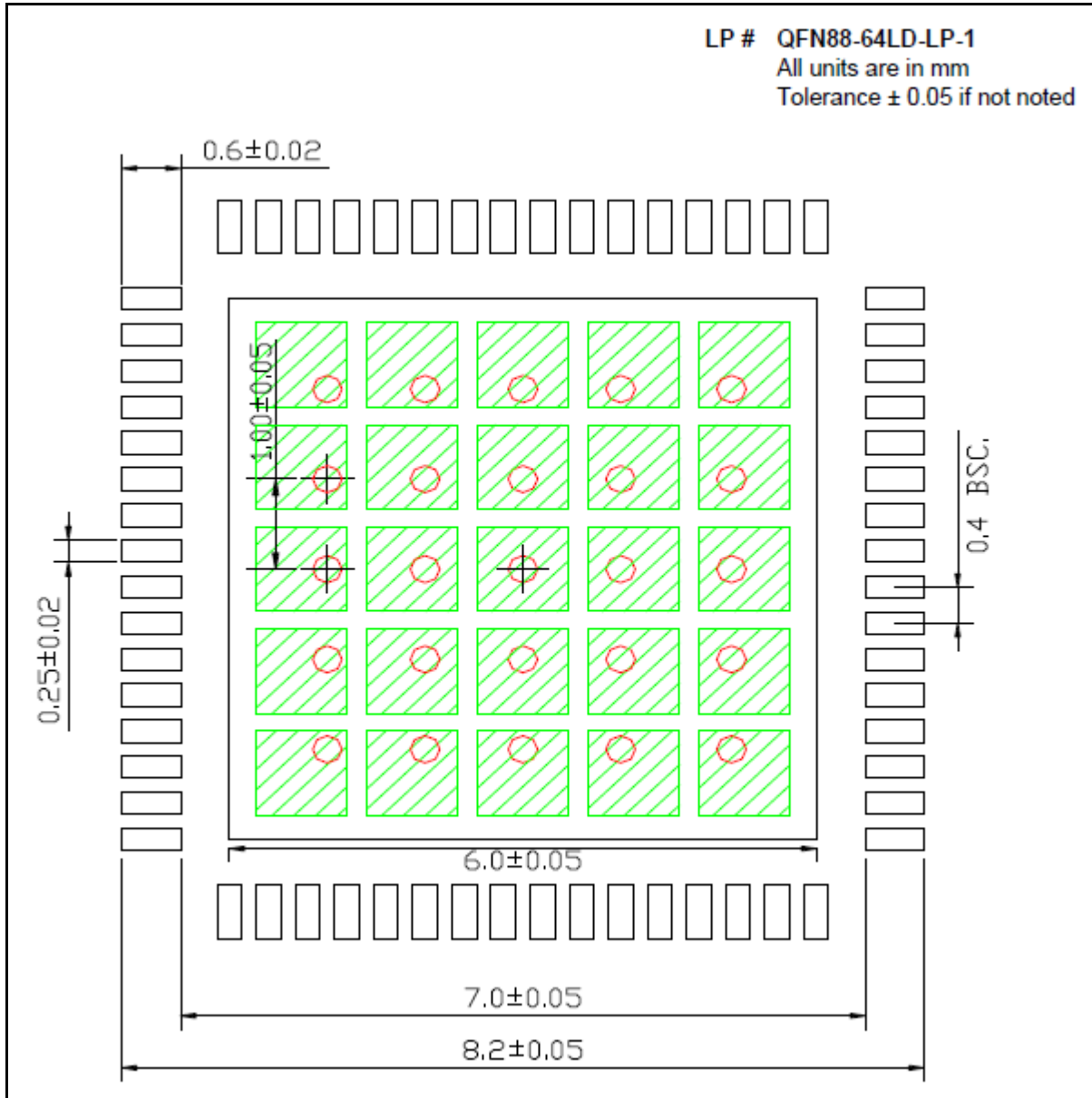
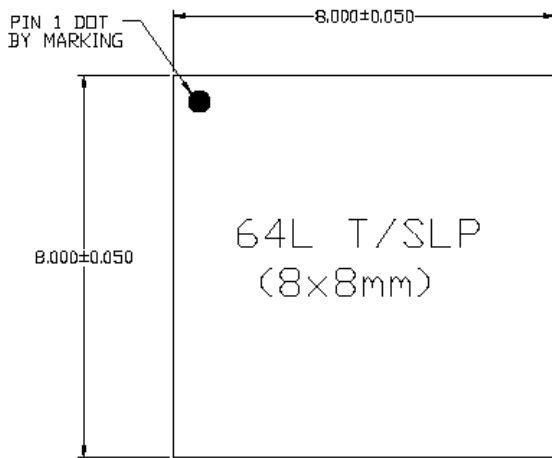

Figure 25. Recommended Land Pattern, 64-Pin (8mm x 8mm) QFN

Red circles indicate thermal vias. They should be 0.350mm in diameter and be connected to the GND plane for maximum thermal performance.

Green rectangles (with shaded area) indicate solder stencil openings on the exposed pad area. They should be 0.93x0.93mm in size, 1.13mm pitch.

Package Information



TOP VIEW

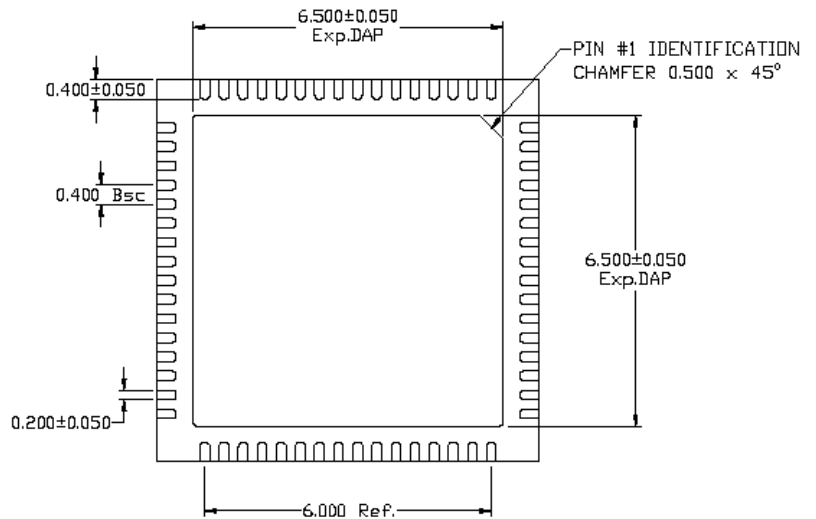

BOTTOM VIEW

NOTE:

1) TSLP AND SLP SHARE THE SAME EXPOSE OUTLINE BUT WITH DIFFERENT THICKNESS:

		TSLP	SLP
A	MAX.	0.800	0.900
	NOM.	0.750	0.850
	MIN.	0.700	0.800

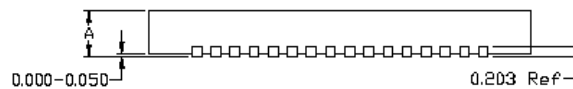

SIDE VIEW

64-Pin (8mm x 8mm) QFN

MICREL, INC. 2180 FORTUNE DRIVE SAN JOSE, CA 95131 USA
 TEL +1 (408) 944-0800 FAX +1 (408) 474-1000 WEB <http://www.micrel.com>

Micrel makes no representations or warranties with respect to the accuracy or completeness of the information furnished in this data sheet. This information is not intended as a warranty and Micrel does not assume responsibility for its use. Micrel reserves the right to change circuitry, specifications and descriptions at any time without notice. No license, whether express, implied, arising by estoppel or otherwise, to any intellectual property rights is granted by this document. Except as provided in Micrel's terms and conditions of sale for such products, Micrel assumes no liability whatsoever, and Micrel disclaims any express or implied warranty relating to the sale and/or use of Micrel products including liability or warranties relating to fitness for a particular purpose, merchantability, or infringement of any patent, copyright or other intellectual property right.

Micrel Products are not designed or authorized for use as components in life support appliances, devices or systems where malfunction of a product can reasonably be expected to result in personal injury. Life support devices or systems are devices or systems that (a) are intended for surgical implant into the body or (b) support or sustain life, and whose failure to perform can be reasonably expected to result in a significant injury to the user. A Purchaser's use or sale of Micrel Products for use in life support appliances, devices or systems is a Purchaser's own risk and Purchaser agrees to fully indemnify Micrel for any damages resulting from such use or sale.

© 2012 Micrel, Incorporated.