

GS2924

300mA CMOS LDO Voltage Regulator

Product Description

The GS2924 is a positive voltage output, three-pin regulator that provides a high current even when the input/output voltage differential is small. Low power consumption and high accuracy is achieved through CMOS and laser trimming technologies.

The GS2924 consists of a high-precision voltage reference, an error correction circuit, and a current limited output driver. Transient response to load variations has improved in comparison to the existing series.

SOT-89 and SOT-23-3L packages are available.

Features

- Maximum output current: 300mA
- Output voltage: 1.5V to 5.0V
- Highly accurate: Output voltage $\pm 2\%$ ($\pm 1\%$ for semi-custom products)
- Low power consumption: Typ. $2.0\mu\text{A}$ at $V_{\text{OUT}}=5.0\text{V}$
- Output voltage temperature coefficient $0.1\%/V$: Typ. $\pm 100\text{ppm}/^\circ\text{C}$
- Input stability: Typ. $2.0\%/V$
- Small input/output differential: 0.12V @ $I_{\text{OUT}}=100\text{mA}$ at $V_{\text{OUT}}=5.0\text{V}$
- On-chip protections: thermal, short circuit

Applications

- Wireless Communication Systems
- Battery Powered Systems
- Portable Cameras and Video Recorders
- Voltage Regulator for Microprocessor
- Palmtops
- Voltage Regulator for CD-ROM Drivers, LAN Cards, 56K Modem

Block Diagram

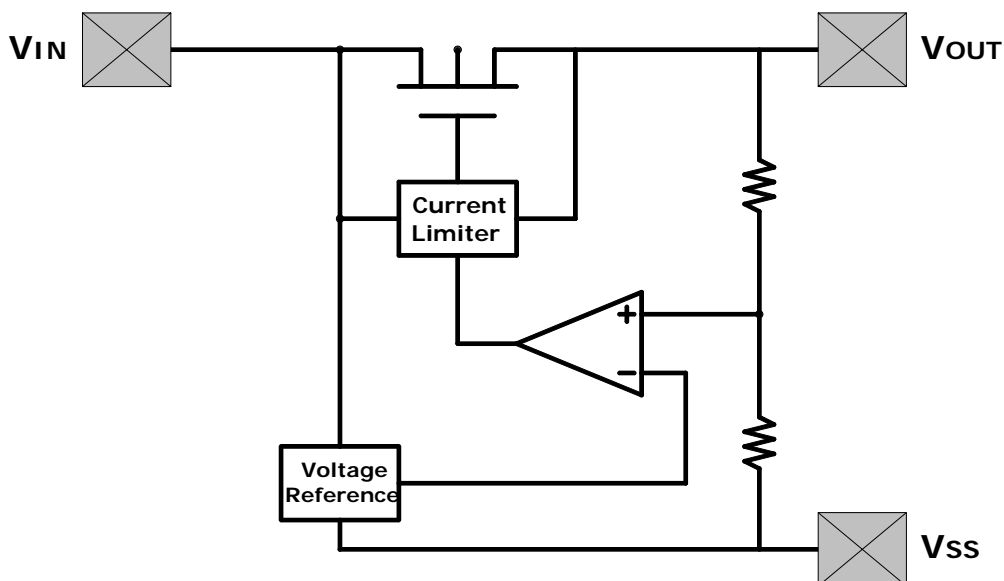

Packages & Pin Assignments

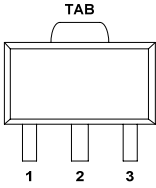
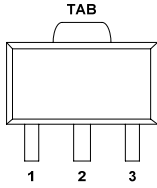
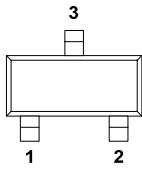
GS2924YT (SOT-89)		GS2924Y (SOT-89)		GS2924Z (SOT-23-3L)	
					
Pin	Pin Name	Pin	Pin Name	Pin	Pin Name
1	GND	1	V _{OUT}	1	GND
2	V _{IN}	2	GND	2	V _{OUT}
3	V _{OUT}	3	V _{IN}	3	V _{IN}

Ordering Information

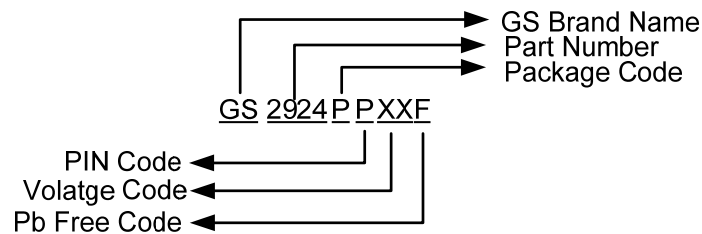

SOT-23-3L		SOT-89		Output
P/N	Marking			
GS2924Z15F	CDG _{YWG}	GS2924YT15F	GS2924Y15F	1.5V
GS2924Z18F	CDF _{YWG}	GS2924YT18F	GS2924Y18F	1.8V
GS2924Z25F	CDH _{YWG}	GS2924YT25F	GS2924Y25F	2.5V
GS2924Z30F	CDQ _{YWG}	GS2924YT30F	GS2924Y30F	3.0V
GS2924Z33F	CDR _{YWG}	GS2924YT33F	GS2924Y33F	3.3V
GS2924Z50F	CDV _{YWG}	GS2924YT50F	GS2924Y50F	5.0V

Marking Information

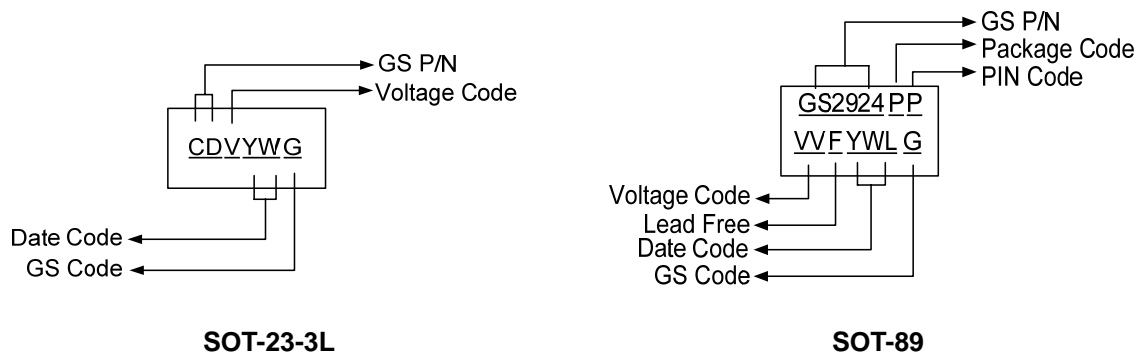

Absolute Maximum Ratings

Symbol	Parameter	Maximum Ratings	Units	
V _{IN}	Input Voltage	-0.3 to 12	V	
I _{OUT}	Output Current	300	mA	
P _D	Power Dissipation	SOT-89	500	mW
		SOT-23-3L	150	
θ _{JA}	Thermal Resistance (Junction to Ambient)	SOT-89	250	°C/W
		SOT-23-3L	833	
T _{OP}	Operating Temperature Range	-40 to +85	°C	
T _{STG}	Storage Temperature Range	-65 to +150	°C	
T _{LEAD}	Lead Temperature (Soldering 10sec)	260	°C	

Note: Stresses above those listed under “Absolute Maximum Ratings” may cause permanent damage to the device. These are stress ratings only and functional operation of the device at these or any other conditions above those indicated in the operation sections of the specifications is not implied.

Exposure to Absolute Maximum Ratings conditions for extended periods may affect device reliability.

Electrical Characteristics

V_{OUT} (T) = 1.5V (Note 1)

Symbol	Parameter	Conditions	Min	Typ	Max	Unit
V _{OUT} (E)	Output voltages (Note 2)	I _{OUT} =40mA ; V _{IN} =2.5V	1.470	1.500	1.530	V
I _{OUT} max	Maximum output current	V _{IN} =2.5V V _{OUT} (E)≥1.35V	100			mA
ΔV _{OUT}	Load stability	V _{IN} =2.5V 1mA≤I _{OUT} ≤60mA		45	90	mV
V _{dif}	Input-Output Voltage differential (Note 3)	I _{OUT} =60mA		180	360	mV
		I _{OUT} =120mA		400	700	mV
I _{SS}	Supply current	V _{IN} =2.5V		1.0	3	μA
$\frac{\Delta V_{OUT}}{\Delta V_{IN} \cdot \Delta V_{OUT}}$	Line regulation	I _{OUT} =40mA 2.5≤V _{IN} ≤10.0V		0.2	0.3	%/V
V _{IN}	Input voltage				10	V
$\frac{\Delta V_{OUT}}{\Delta T_{opr} \cdot \Delta V_{OUT}}$	Output voltage Temperature characteristics	I _{OUT} =40mA -40°C≤T _{opr} ≤85°C		±100		ppm/°C

Electrical Characteristics (Continue)

$V_{OUT}(T) = 1.8V$ (Note 1)

Symbol	Parameter	Conditions	Min	Typ.	Max	Unit
$V_{OUT}(E)$	Output voltages (Note 2)	$I_{OUT}=40mA$; $V_{IN}=2.8V$	1.764	1.800	1.836	V
$I_{OUT\ max}$	Maximum output current	$V_{IN}=2.8V$ $V_{OUT}(E) \geq 1.62V$	100			mA
ΔV_{OUT}	Load stability	$V_{IN}=2.8V$ $1mA \leq I_{OUT} \leq 60mA$		45	90	mV
V_{dif}	Input-Output Voltage differential (Note 3)	$I_{OUT}=60mA$		180	360	mV
		$I_{OUT}=120mA$		400	700	mV
I_{SS}	Supply current	$V_{IN}=2.8V$		1.0	3	μA
$\frac{\Delta V_{OUT}}{\Delta V_{IN} \cdot \Delta V_{OUT}}$	Line regulation	$I_{OUT}=40mA$ $2.8V \leq V_{IN} \leq 10.0V$		0.2	0.3	%/V
V_{IN}	Input voltage				10	V
$\frac{\Delta V_{OUT}}{\Delta T_{opr} \cdot \Delta V_{OUT}}$	Output voltage Temperature characteristics	$I_{OUT}=40mA$ $-40^{\circ}C \leq T_{opr} \leq 85^{\circ}C$		± 100		ppm/ $^{\circ}C$

$V_{OUT}(T) = 2.5V$ (Note 1)

Symbol	Parameter	Conditions	Min	Typ.	Max	Unit
$V_{OUT}(E)$	Output voltages (Note 2)	$I_{OUT}=40mA$; $V_{IN}=3.5V$	2.450	2.500	2.550	V
$I_{OUT\ max}$	Maximum output current	$V_{IN}=3.5V$ $V_{OUT}(E) \geq 2.25V$	150			mA
ΔV_{OUT}	Load stability	$V_{IN}=3.5V$ $1mA \leq I_{OUT} \leq 80mA$		45	90	mV
V_{dif}	Input-Output Voltage differential (Note 3)	$I_{OUT}=80mA$		180	360	mV
		$I_{OUT}=160mA$		400	700	mV
I_{SS}	Supply current	$V_{IN}=3.5V$		1.0	3	μA
$\frac{\Delta V_{OUT}}{\Delta V_{IN} \cdot \Delta V_{OUT}}$	Line regulation	$I_{OUT}=40mA$ $3.5V \leq V_{IN} \leq 10.0V$		0.2	0.3	%/V
V_{IN}	Input voltage				10	V
$\frac{\Delta V_{OUT}}{\Delta T_{opr} \cdot \Delta V_{OUT}}$	Output voltage Temperature characteristics	$I_{OUT}=40mA$ $-40^{\circ}C \leq T_{opr} \leq 85^{\circ}C$		± 100		ppm/ $^{\circ}C$

Electrical Characteristics (Continue)

$V_{OUT}(T) = 3.0V$ (Note 1)

Symbol	Parameter	Conditions	Min	Typ.	Max	Unit
$V_{OUT}(E)$	Output voltages (Note 2)	$I_{OUT}=40mA$; $V_{IN}=4.0V$	2.940	3.000	3.060	V
$I_{OUT\ max}$	Maximum output current	$V_{IN}=4.0V$ $V_{OUT}(E) \geq 2.7V$	155			mA
ΔV_{OUT}	Load stability	$V_{IN}=4.0V$ $1mA \leq I_{OUT} \leq 60mA$		45	90	mV
V_{dif}	Input-Output Voltage differential (Note 3)	$I_{OUT}=60mA$		180	360	mV
		$I_{OUT}=120mA$		400	700	mV
I_{SS}	Supply current	$V_{IN}=4.0V$		1.0	3	μA
$\frac{\Delta V_{OUT}}{\Delta V_{IN} \cdot \Delta V_{OUT}}$	Line regulation	$I_{OUT}=40mA$ $4.0V \leq V_{IN} \leq 10.0V$		0.2	0.3	%/V
V_{IN}	Input voltage				10	V
$\frac{\Delta V_{OUT}}{\Delta T_{opr} \cdot \Delta V_{OUT}}$	Output voltage Temperature characteristics	$I_{OUT}=40mA$ $-40^{\circ}C \leq T_{opr} \leq 85^{\circ}C$		± 100		ppm/ $^{\circ}C$

$V_{OUT}(T) = 3.3V$ (Note 1)

Symbol	Parameter	Conditions	Min	Typ.	Max	Unit
$V_{OUT}(E)$	Output voltages (Note 2)	$I_{OUT}=40mA$; $V_{IN}=4.3V$	3.234	3.3	3.366	V
$I_{OUT\ max}$	Maximum output current	$V_{IN}=4.3V$ $V_{OUT}(E) \geq 2.97V$	165			mA
ΔV_{OUT}	Load stability	$V_{IN}=4.3V$ $1mA \leq I_{OUT} \leq 80mA$		45	90	mV
V_{dif}	Input-Output Voltage differential (Note 3)	$I_{OUT}=160mA$		400	700	mV
I_{SS}	Supply current	$V_{IN}=4.3V$		1.0	3	μA
$\frac{\Delta V_{OUT}}{\Delta V_{IN} \cdot \Delta V_{OUT}}$	Line regulation	$I_{OUT}=40mA$ $4.3V \leq V_{IN} \leq 10.0V$		0.2	0.3	%/V
V_{IN}	Input voltage				10	V
$\frac{\Delta V_{OUT}}{\Delta T_{opr} \cdot \Delta V_{OUT}}$	Output voltage Temperature characteristics	$I_{OUT}=40mA$ $-40^{\circ}C \leq T_{opr} \leq 85^{\circ}C$		± 100		ppm/ $^{\circ}C$

Electrical Characteristics (Continue)

$V_{OUT}(T) = 5.0V$ (Note 1)

Symbol	Parameter	Conditions	Min	Typ	Max	Unit
$V_{OUT}(E)$	Output voltages (Note 2)	$I_{OUT}=40mA$; $V_{IN}=6.0V$	4.900	5.000	5.100	V
$I_{OUT\ max}$	Maximum output current	$V_{IN}=6.0V$ $V_{OUT}(E) \geq 5.0V$	165			mA
ΔV_{OUT}	Load stability	$V_{IN}=6.0V$ $1mA \leq I_{OUT} \leq 80mA$		45	90	mV
V_{dif}	Input-Output Voltage differential (Note 3)	$I_{OUT}=200mA$		380	600	mV
I_{SS}	Supply current	$V_{IN}=6.0V$		1.0	3	μA
$\frac{\Delta V_{OUT}}{\Delta V_{IN} \bullet \Delta V_{OUT}}$	Line regulation	$I_{OUT}=40mA$ $6.0V \leq V_{IN} \leq 10.0V$		0.2	0.3	%/V
V_{IN}	Input voltage				10	V
$\frac{\Delta V_{OUT}}{\Delta T_{opr} \bullet \Delta V_{OUT}}$	Output voltage Temperature characteristics	$I_{OUT}=40mA$ $-40^{\circ}C \leq T_{opr} \leq 85^{\circ}C$		± 100		ppm/ $^{\circ}C$

Note 1. $V_{OUT}(T)$ = Specified output voltage.

Note 2. $V_{OUT}(E)$ = Effective output voltage (i.e. the output voltage when “ $V_{OUT}(T)+1.0V$ ” is provided at the V_{IN} pin while maintaining a certain I_{OUT} value.)

Note 3. $V_{dif} = (V_{IN\ 1} \text{ (Note 4)} - V_{OUT}(E))$

Note 4. $V_{IN\ 1}$ = The input voltage at the time 98% of $V_{OUT}(E)$ is output (input voltage has been gradually reduced).

Typical Performance Characteristics

Output Voltage vs. Output Current

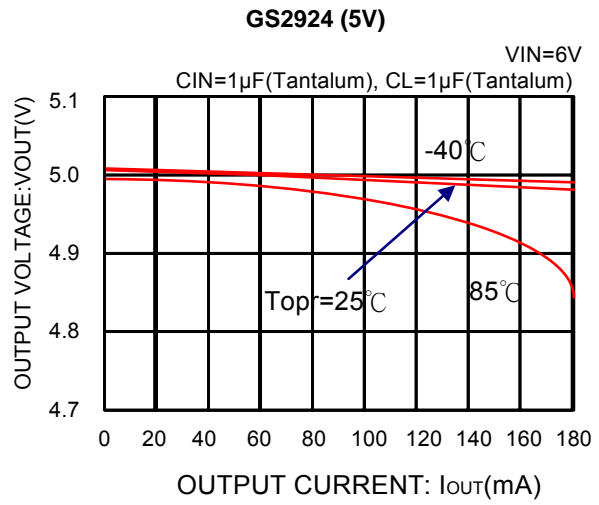
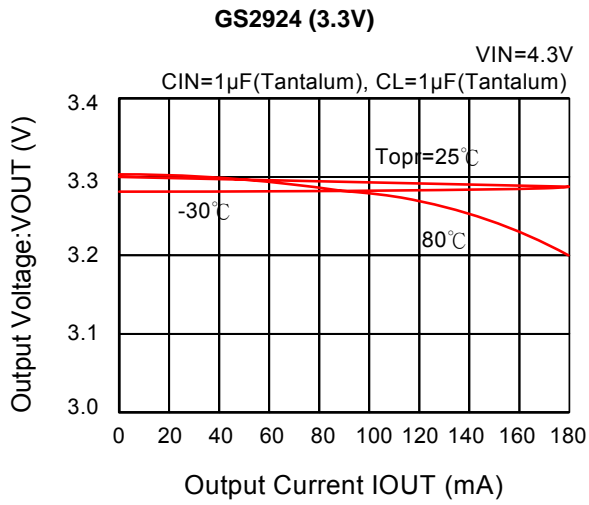

Output Voltage vs. Input Voltage

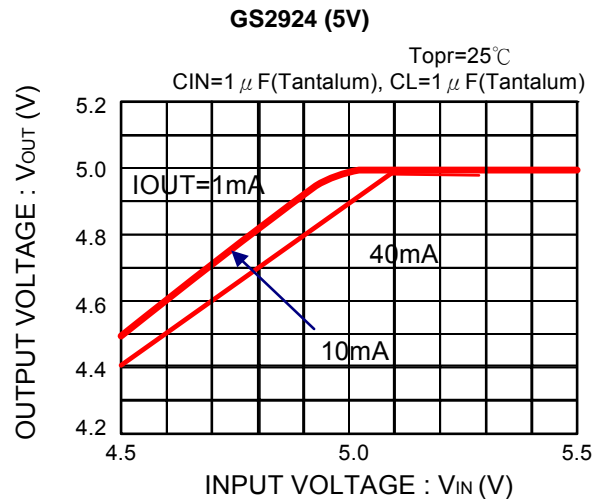
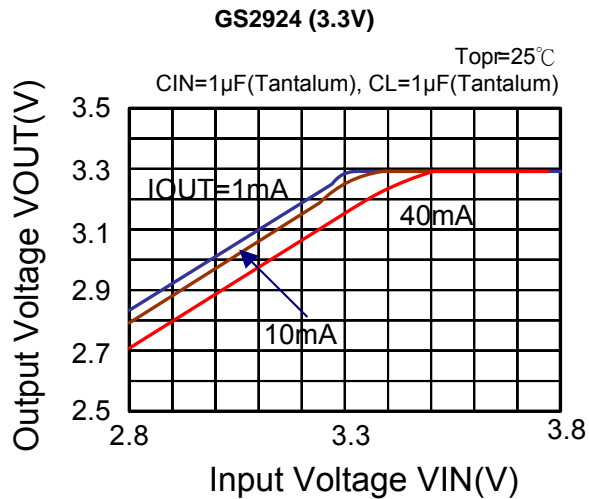

Input/Output Voltage Differential vs. Output Current

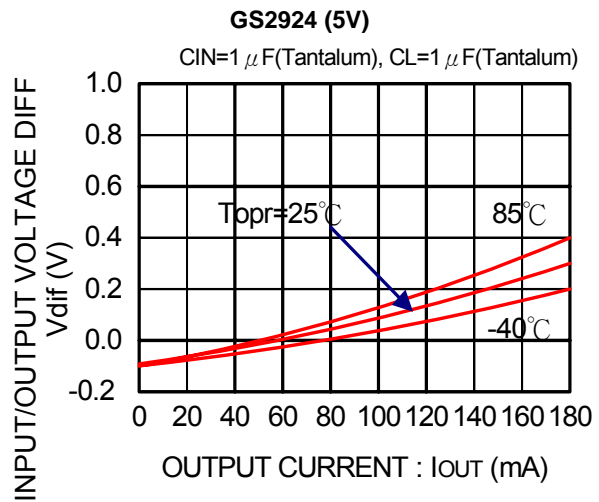
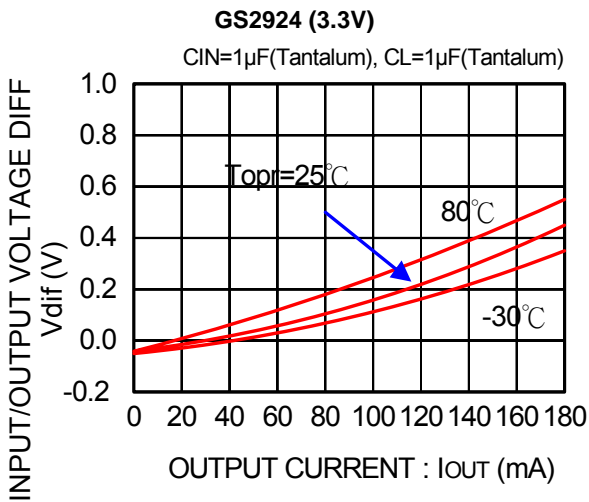

Typical Performance Characteristics (Continue)

Supply Current vs. Input Voltage

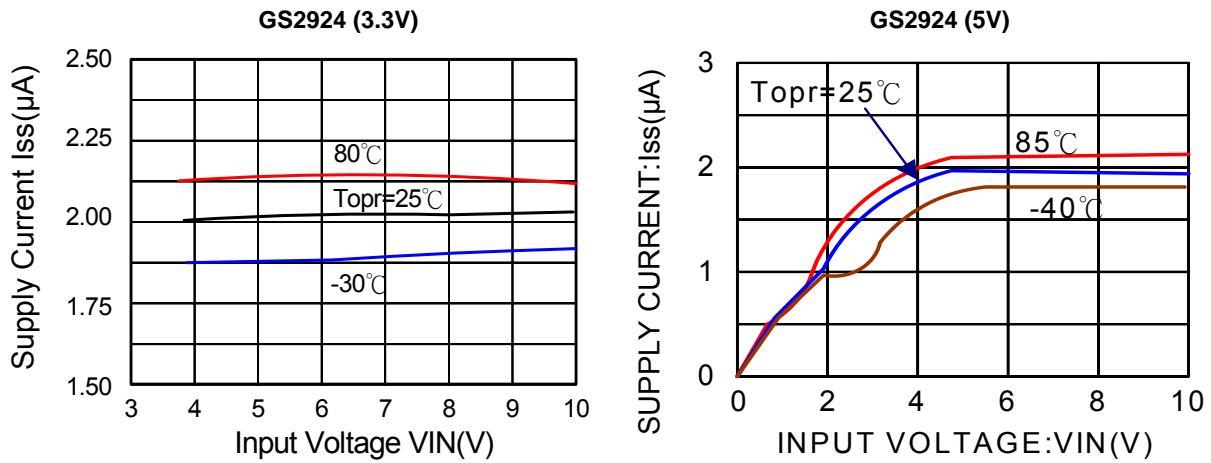

Load Transient Response

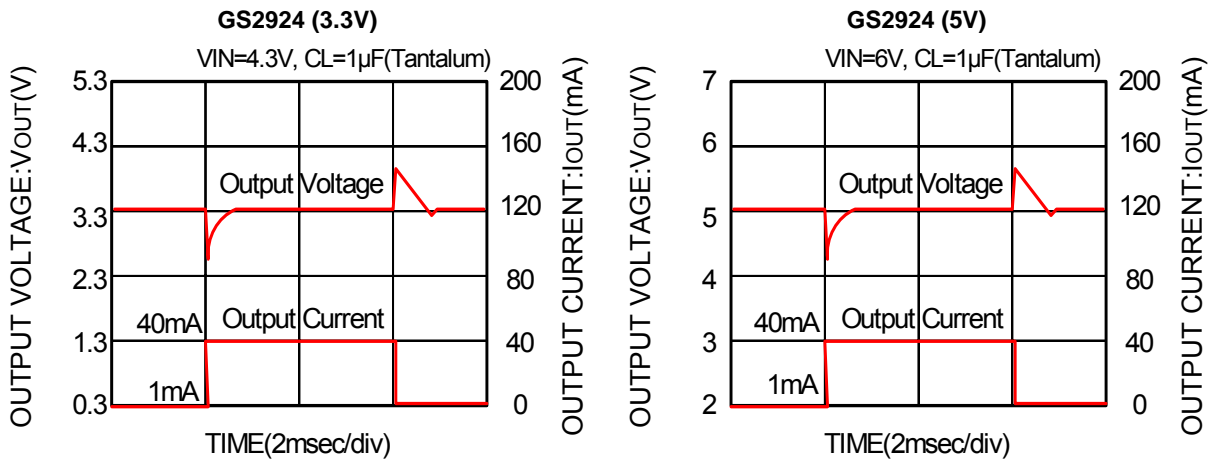

Typical Application Circuits

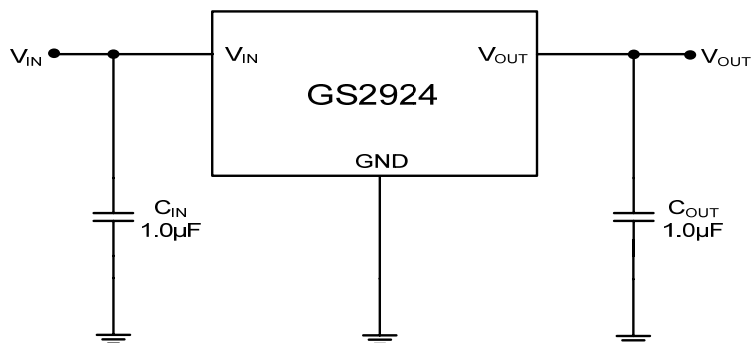

NOTES ON USE

1. There is a possibility that oscillation may occur as a result of the impedance present between the power supply and the IC's input. Where impedance is 10Ω or more, please use a capacitor (C_{IN}) of at least $1\mu F$. With a large output current, operations can be stabilized by increasing capacitor size (C_{IN}). If C_{IN} is small and capacitor size (C_L) is increased, there is a possibility of oscillation due to input impedance. In such cases, either increasing the size of C_{IN} or decreasing the size of C_L can stabilize operations.
2. Please ensure that output current (I_{OUT}) is less than $P_D + (V_{IN} - V_{OUT})$ and does not exceed the stipulated Continuous Total Power Dissipation value (P_D).

Package Dimension

SOT-89 PLASTIC PACKAGE

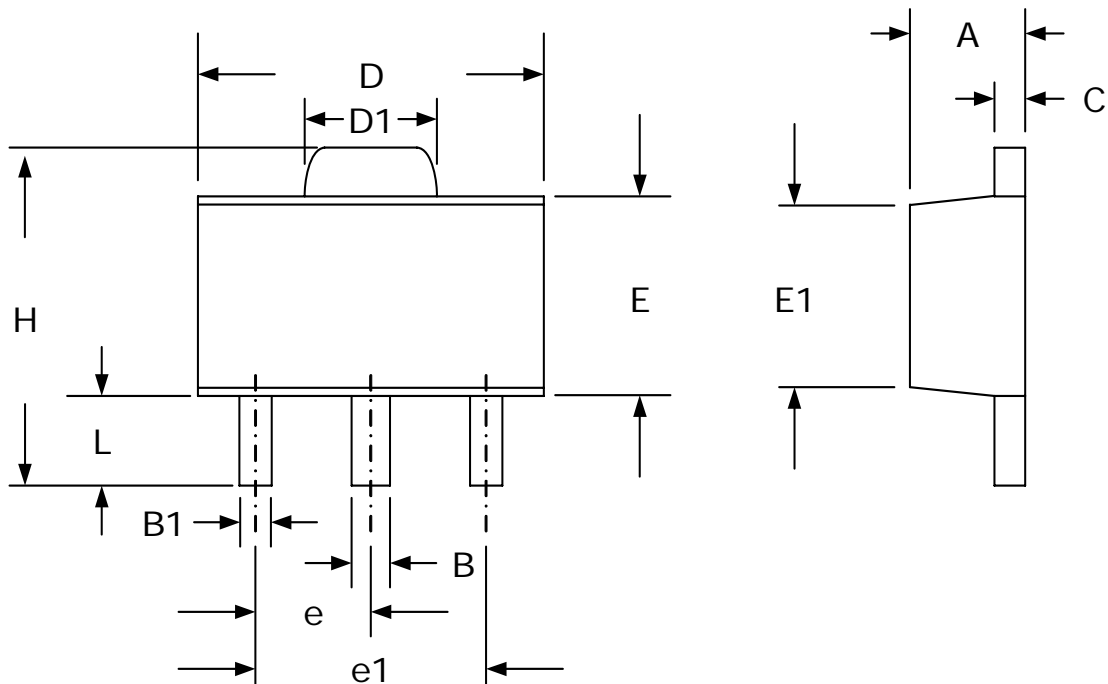

Dimensions				
SYMBOL	Millimeters		Inches	
	MIN	MAX	MIN	MAX
A	1.40	1.60	.055	.063
B	0.44	0.56	.017	.022
B1	0.36	0.48	.014	.019
C	0.35	0.44	.014	.017
D	4.40	4.60	.173	.181
D1	1.62	1.83	.064	.072
E	2.29	2.60	.090	.102
E1	2.13	2.29	.084	.090
e	1.50 (TYP)		.059 (TYP)	
e1	3.00 (TYP)		.118 (TYP)	
H	3.94	4.25	.155	.167
L	0.89	1.20	.035	.047

SOT-23-3L PLASTIC PACKAGE

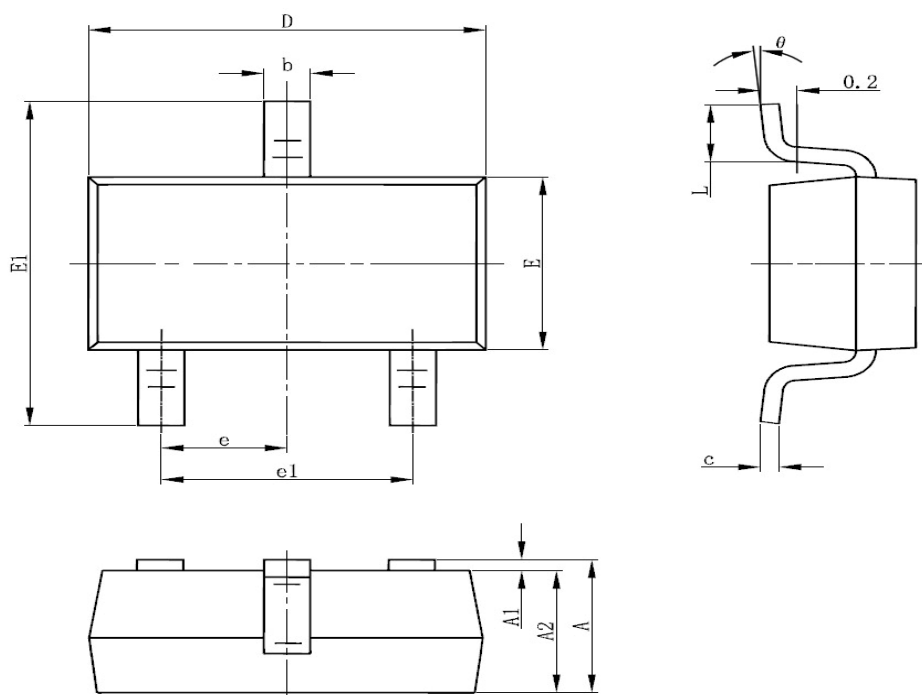





Dimensions



SYMBOL	Millimeters		Inches	
	MIN	MAX	MIN	MAX
A	1.05	1.25	0.041	0.049
A1	0	0.1	0	0.004
A2	1.05	1.15	0.041	0.045
b	0.3	0.5	0.012	0.020
c	0.1	0.2	0.004	0.008
D	2.82	3.02	0.111	0.119
E	1.5	1.7	0.059	0.067
E1	2.65	2.95	0.104	0.116
e	0.950 (TYP)		0.037 (TYP)	
e1	1.8	2	0.071	0.079
L	0.3	0.6	0.012	0.024
Q	0°	8°	0°	8°

NOTICE

Information furnished is believed to be accurate and reliable. However Globaltech Semiconductor assumes no responsibility for the consequences of use of such information nor for any infringement of patents or other rights of third parties, which may result from its use. No license is granted by implication or otherwise under any patent or patent rights of Globaltech Semiconductor. Specifications mentioned in this publication are subject to change without notice. This publication supersedes and replaces all information without express written approval of Globaltech Semiconductor.

CONTACT US

GS Headquarter	
	4F.,No.43-1,Lane11,Sec.6,Minquan E.Rd NeiHu District Taipei City 114, Taiwan (R.O.C)
	886-2-2657-9980
	886-2-2657-3630
	sales_twn@gs-power.com

Shenzhen Branch(China)	
	1113 B Building, Happiness Washington, Baoan Nan Road, Luohu District, Shenzhen City, China
	0755-22208941
	sales_cn@gs-power.com

RD Division	
	824 Bolton Drive Milpitas. CA. 95035
	1-408-457-0587