

TLE4941plusC

Advanced Differential Speed Sensor

TLE4941plusC
TLE4941plusCB

Product Information

2014-03-10

Table of Contents

	Table of Contents	2
1	General	3
1.1	Target Application	3
1.2	Features	3
2	Functional Description	4
2.1	General	4
2.2	Marking and data matrix code description	4
2.3	Output Description	5
2.4	Under voltage Behavior	5
3	Specification	6
3.1	Operating Range	6
3.2	Electrical Characteristics	6
3.3	Magnetic Characteristics	7
3.3.1	Description of Magnetic Field	7
3.4	Application Circuit	9
3.5	Typical Diagrams (measured performance)	9
3.6	Typical Operating Characteristics - TLE4941plusCB	11
3.7	Reference Target Wheel - TLE4941plusCB	11
4	Package Information	12
4.1	Package and Packing Dimensions - TLE4941plusC	12
4.2	Package and Packing Dimensions - TLE4941plusCB	14

1 General



1.1 Target Application

The Hall Effect sensor IC TLE4941plusC is designed to provide information about rotational speed to modern vehicle dynamics control systems and Anti-Lock Braking Systems (ABS). The output has been designed as a two wire current interface. The sensor operates without external components and combines a fast power-up time with a low cut-off frequency. Designed specifically to meet harsh automotive requirements, excellent accuracy and sensitivity is specified over a wide temperature range and robustness to ESD and EMC has been maximized. State-of-the art BiCMOS technology is used for monolithic integration of the active sensor areas and the signal conditioning circuitry. Finally, the optimized piezo compensation and the integrated dynamic offset compensation enables ease of manufacturing and the elimination of magnetic offsets.

The TLE4941plusC is provided with an overmolded 1.8 nF capacitor for improved EMC performance. Infineon also offers customer the possibility to buy sensors with already attached back bias magnets (CB version).

1.2 Features

- Two-wire current interface
- Dynamic self-calibration principle
- Single chip solution
- No external components needed
- High sensitivity
- South and north pole pre-induction possible
- High resistive to piezo effects
- Large operating air-gaps
- Wide operating temperature range
- TLE4941plusC: 1.8 nF overmolded capacitor
- Applicable for small pitches (2mm Hall element distance)
- Integrated back bias magnet as an option

Type	Order Code	Marking	Package
TLE4941plusC	SP000478508	41CPA	PG-SSO-2-53
TLE4941plusCB	SP000913556	941D00	PG-SSOM-2-11

2 Functional Description

2.1 General

The differential Hall sensor IC detects the motion of ferromagnetic and permanent magnet structures by measuring the differential flux density of the magnetic field. To detect the motion of ferromagnetic objects the magnetic field must be provided by a back biasing permanent magnet. Either south or north pole of the magnet can be attached to the back side of the IC package.

Magnetic offsets of up to $\pm 30\text{mT}$ and device offsets are cancelled by a self-calibration algorithm. Only a few magnetic edges are necessary for self-calibration. After the offset calibration sequence, switching occurs when the input signal crosses the arithmetic mean of its max. and min. value (e.g. zero-crossing for sinusoidal signals). The ON and OFF state of the IC are indicated by **High** and **Low** current consumption.

2.2 Marking and data matrix code description

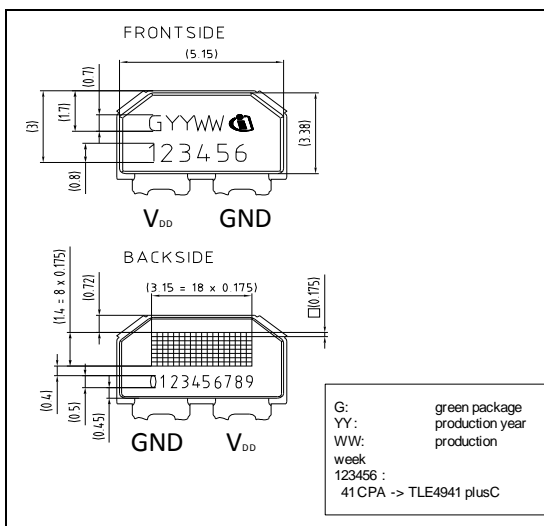

Figure 2-1 Front side and Backside Marking of PG-SSO-2-53

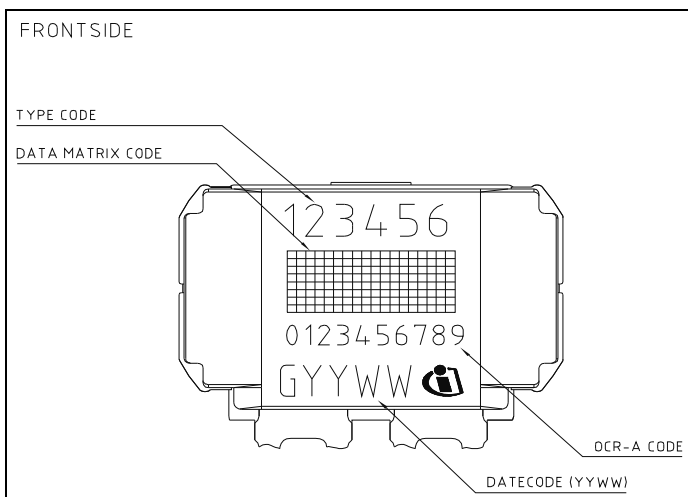

Figure 2-2 Marking of PG-SSO-2-53

2.3 Output Description

Under ideal conditions, the output shows a duty cycle of 50%. Under real conditions, the duty cycle is determined by the mechanical dimensions of the target wheel and its tolerances (40% to 60% might be exceeded for pitch >> 4mm due to the zero-crossing principle).

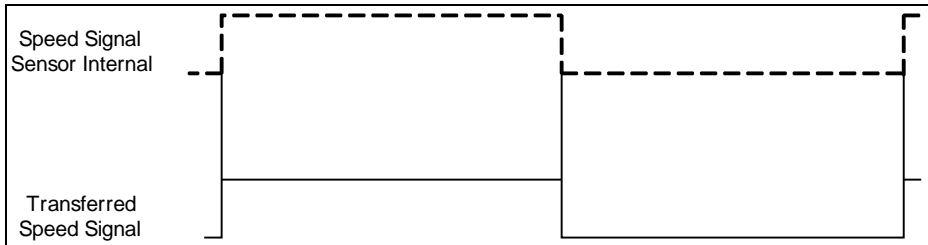

Figure 2-3 Speed Signal (half a period = $0.5 \times 1/f_{\text{speed}}$)

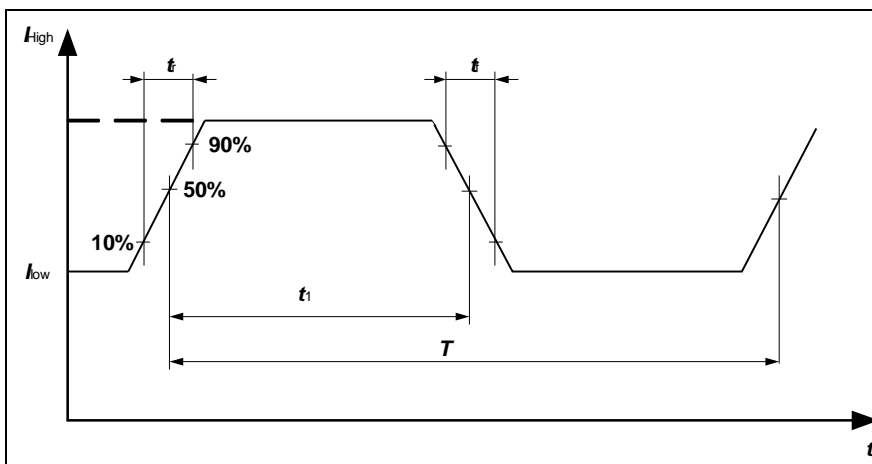

Figure 2-4 Definition of Rise and Fall Time; Duty Cycle = $t_1/T \times 100\%$

2.4 Under voltage Behavior

The voltage supply comparator has an integrated hysteresis V_{hys} with the maximum value of the release level $V_{\text{rel}} < 4.5\text{V}$. This determines the minimum required supply voltage V_{DD} of the chip. A minimum hysteresis V_{hys} of 0.7V is implemented thus avoiding a toggling of the output when the supply voltage V_{DD} is modulated due to the additional voltage drop at R_{M} when switching from low to high current level and $V_{\text{DD}} = 4.5\text{V}$ (designed for use with $R_{\text{M}} = 75\Omega$).

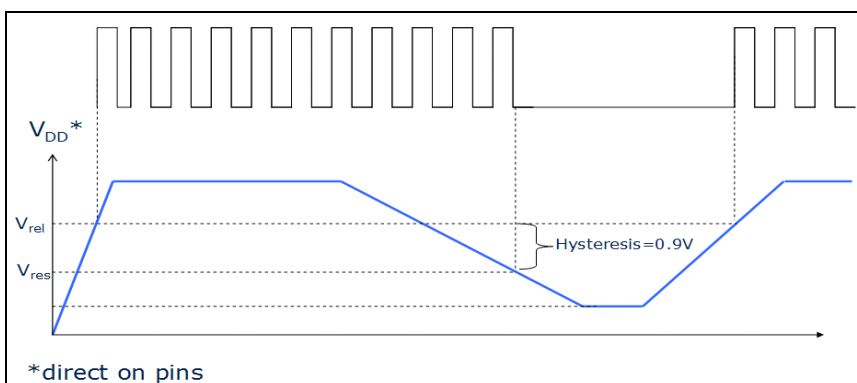

Figure 2-5 Start-up and undervoltage behavior

3 Specification

3.1 Operating Range

Table 3-1 Operating Range

Parameter	Symbol	Values		Unit	Note / Test Condition
		Min.	Max.		
Supply voltage	V_{DD} Extended Range	4.5 20	20 24	V	Directly on IC leads; includes not the voltage drop at R_m
Junction temperature	T_j	-40	+170	°C	time limited
Pre-induction	B_0	-500	+500	mT	
Pre-induction offset between outer probes	$\Delta B_{stat., lr}$	-30	+30	mT	
Differential Induction	ΔB	-120	+120	mT	
Magnetic signal frequency	f_{mag}	1	10000	Hz	

3.2 Electrical Characteristics

Table 3-2 Electrical Characteristics

Parameter	Symbol	Values			Unit	Note / Test Condition
		Min.	Typ.	Max.		
Supply current	I_{Low}	5.9	7	8.4	mA	
Supply current	I_{High}	11.8	14	16.8	mA	
Output rise/fall slew rate TLE4941plusC	t_r, t_f	8 8		22 26	mA/ μ s	$R_M = 75 \Omega \pm 5\%$ $T_j < 125^\circ\text{C}$ $T_j < 170^\circ\text{C}$
Power up time				100	us	
Magnetic edges required for offset calibration	n_{start}			4	magn. edges	5 th edge correct
Number of edges in uncalibrated mode	$n_{DZ-Startup}$			4	edges	
Number of edges suppressed				0		after power on or reset
Magnetic edges required for first output pulse		1		2		after power on or reset
Duty cycle	DC	40	50	60	%	@ $\Delta B \geq 2$ mT sine wave see Figure 6
Signal frequency	f	1 2500		2500 10000	Hz	

Table 3-2 Electrical Characteristics

Parameter	Symbol	Values			Unit	Note / Test Condition
		Min.	Typ.	Max.		
Time before chip reset	Δt_{Reset}	590		848	ms	
Signal behavior after undervoltage or standstill $> t_{\text{Reset}}$ Number of magnetic edges where the first switching occur	$n_{\text{DZ-Start}}$	1		2	edge	Magnetic edge amplitude according to $\Delta \hat{B}_{\text{startup}} \cdot t_{\text{d,input}}$ has to be taken into account

3.3 Magnetic Characteristics

Table 3-3 Magnetic Characteristics

Parameter	Symbol	Values			Unit	Note / Test Condition
		Min.	Typ.	Max.		
Limit threshold $1 \text{ Hz} < f_{\text{mag}} < 2500 \text{ Hz}$ $2500 \text{ Hz} < f_{\text{mag}} < 10000 \text{ Hz}$	ΔB_{Limit}		0.7		mT	–
Magnetic differential field change necessary for startup $1 \text{ Hz} < f < 2500 \text{ Hz}$ $2500 \text{ Hz} < f < 10000 \text{ Hz}$	$\Delta \hat{B}_{\text{startup}}$		1.4		mT	Magnetic field change for startup with the first edge

3.3.1 Description of Magnetic Field

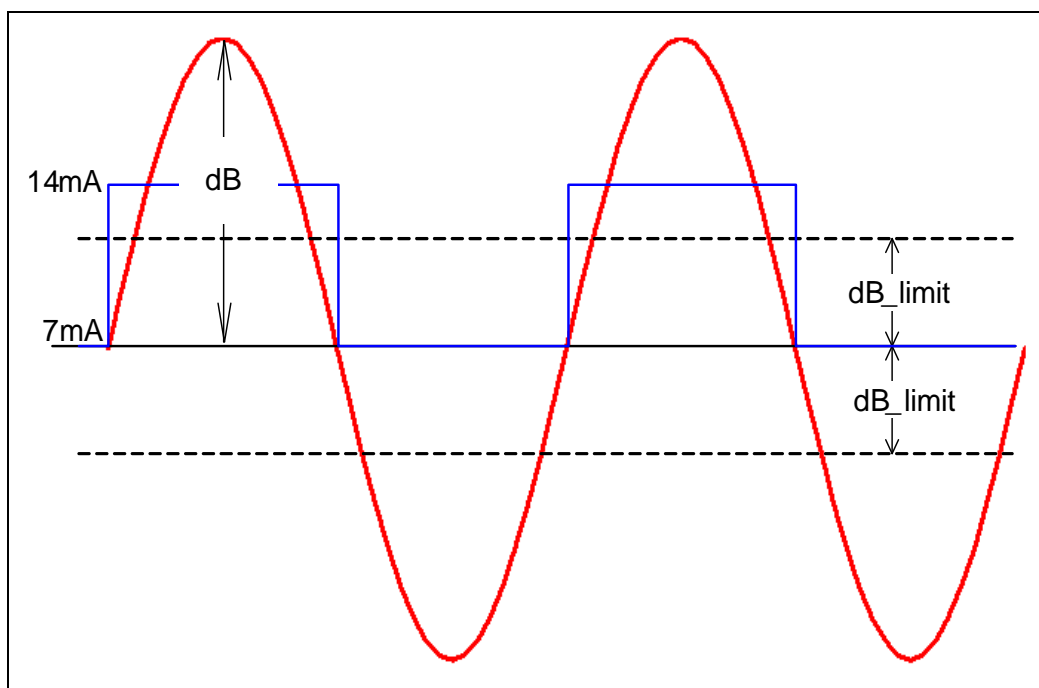

Figure 3-1 Description of differential field dB and switching threshold dB_{limit} (calibrated mode)

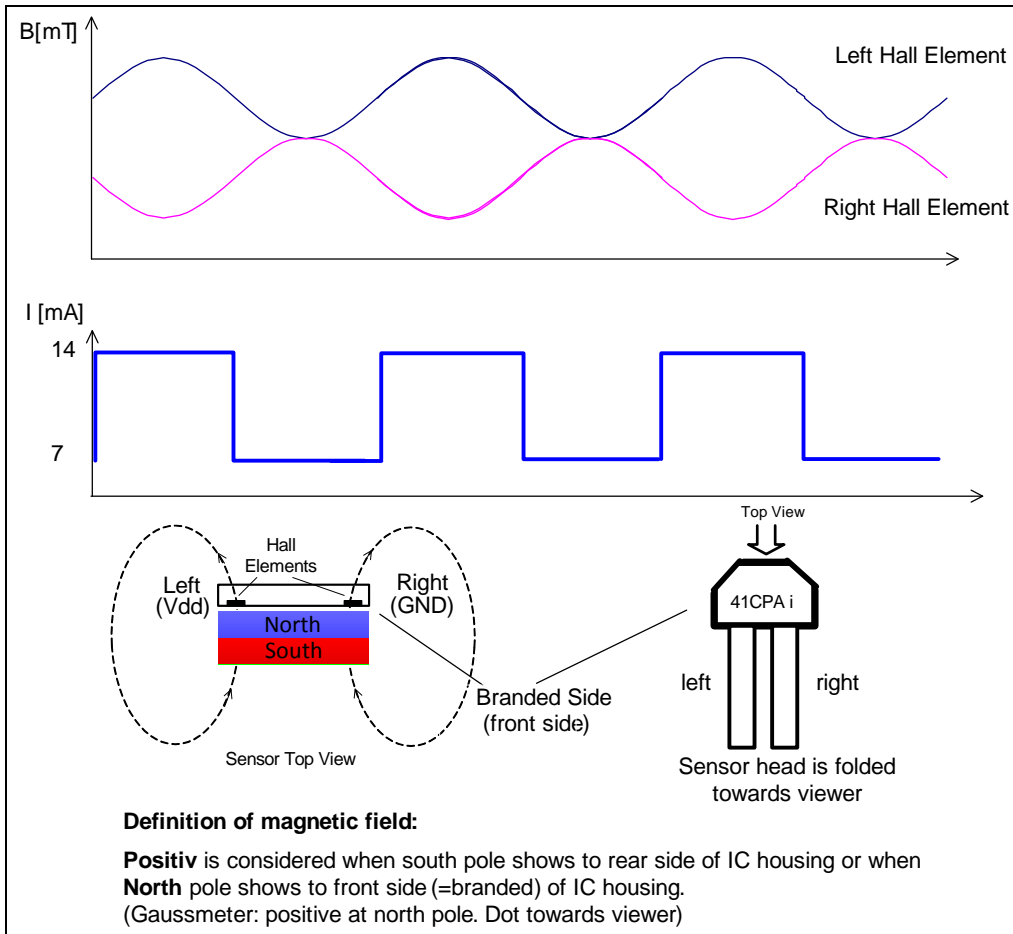

Figure 3-2 Definition of field direction and sensor switching

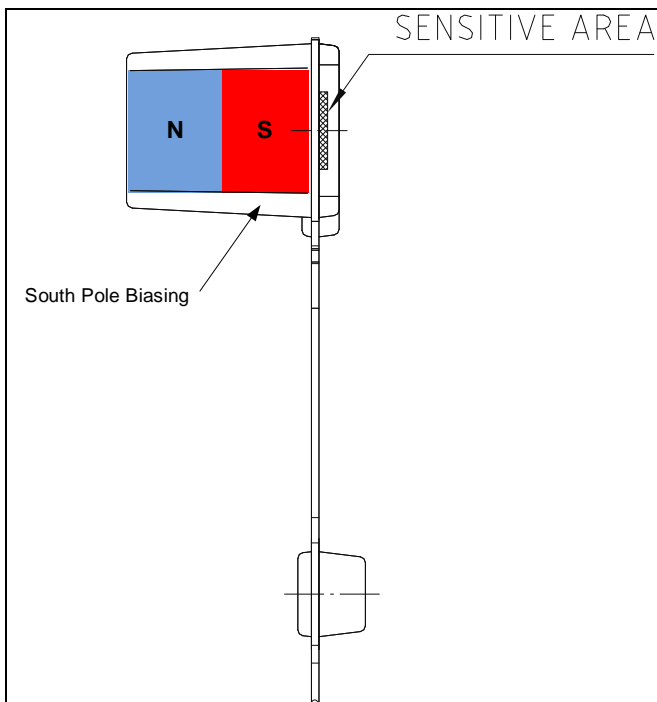

Figure 3-3 Back-Bias field orientation - TLE4941plusCB

3.4 Application Circuit

Circuit below shows the recommended application circuit with reverse bias and overvoltage protection.

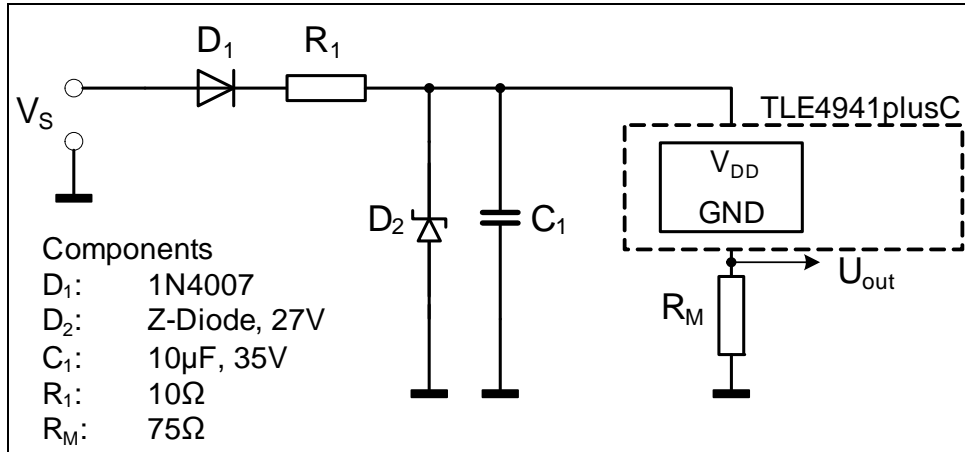

Figure 3-4 Application Circuit

Note: An implementation of 10Ω in VDD path reduces minimum power supply direct on leads of the sensor, but decreases max current at D₂ and makes PCB more robust. This PCB represents a compromise of minimum power supply and current flow on D₂. With higher values than 10Ω a higher minimum supply voltage and higher robustness is reached.

3.5 Typical Diagrams (measured performance)

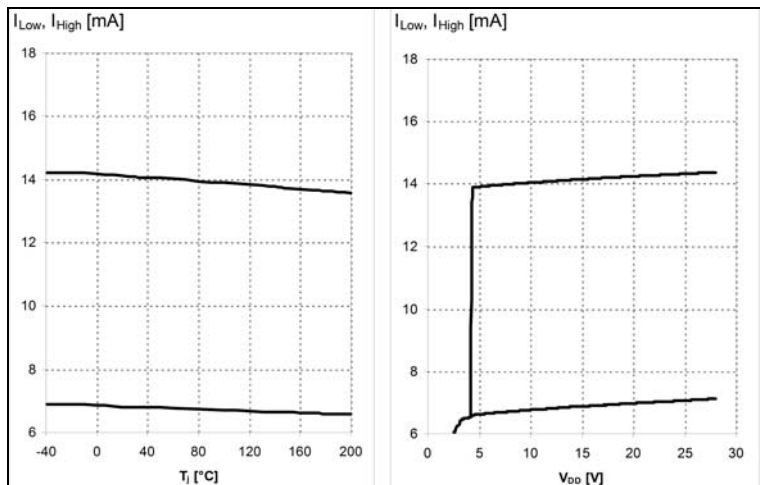

Figure 3-5 Supply Current = $f(T)$ (left), Supply Current = $f(V_{DD})$ (right)

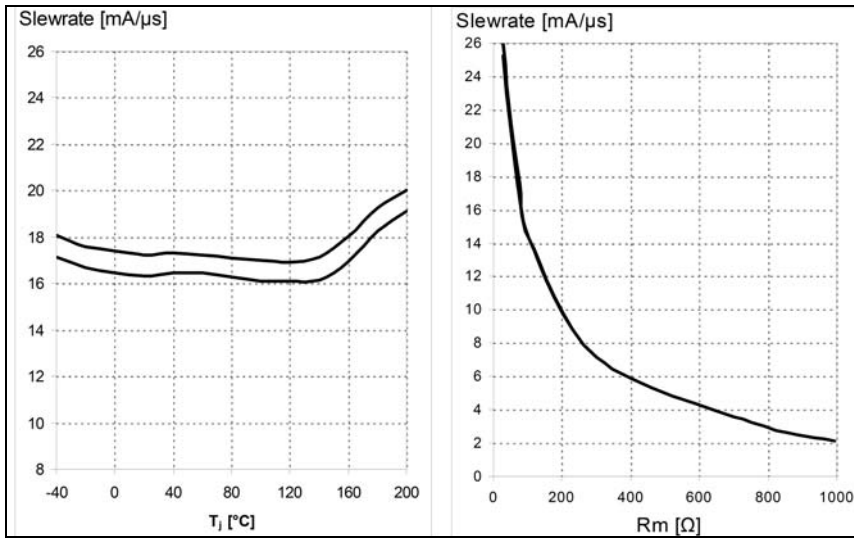

Figure 3-6 Slew Rate = $f(T)$, $R_M = 75 \Omega$ (left), Slew Rate = $f(R_M)$ (right)

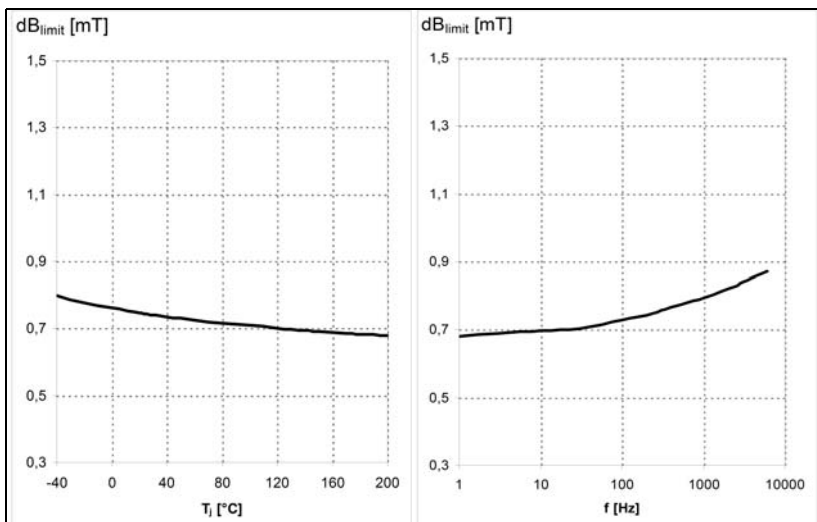

Figure 3-7 Magnetic Threshold $\Delta B_{Limit} = f(T)$ at $f = 200\text{Hz}$ (left), Magnetic Threshold $\Delta B_{Limit} = f(f)$ (right)

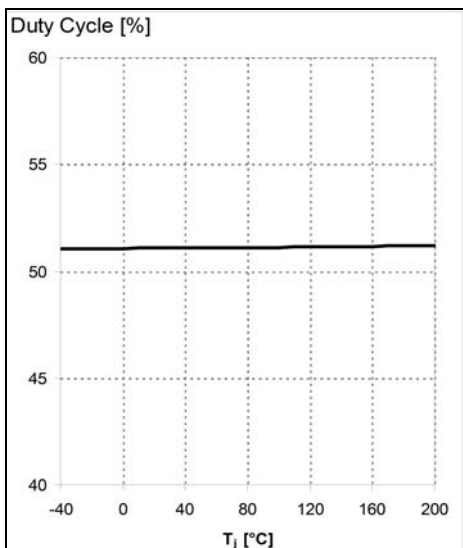

Figure 3-8 Duty Cycle [%] $\Delta B = 2 \text{ mT}$ at 1 kHz

3.6 Typical Operating Characteristics - TLE4941plusCB

Parameters valid for the described reference target wheel.

Table 3-4 Operating Characteristics

Parameter	Symbol	Limit Value			Unit	Remarks
		min	typ	max		
Operating Airgap	AG	0.5		3.2	mm	AG=0 at sensor housing (branded side). Valid at 25°C & 0h. No missing output pulses.

3.7 Reference Target Wheel - TLE4941plusCB

Air gap measurements and functional tests are done with the target wheel described below. Any other wheel can be used. The air gap achieved depends on the material, tooth pitch and width of the target wheel.

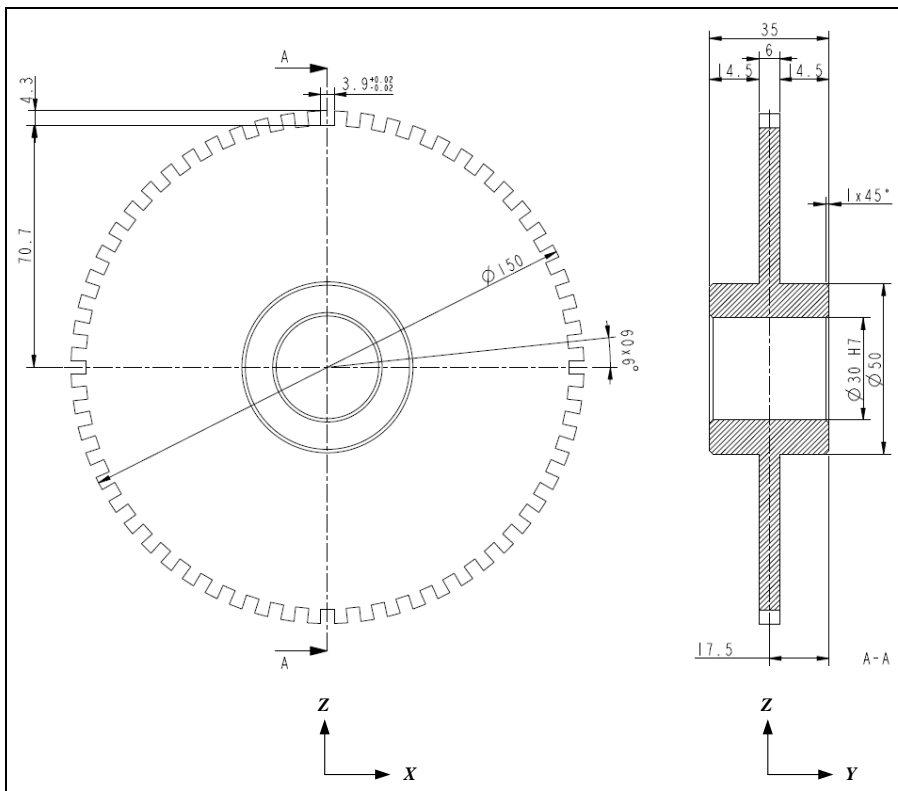

Figure 3-9 Top view of reference target wheel

Table 3-5 Reference target wheel geometry

Parameter	Symbol	Typ value	Unit	Remarks
Outside diameter	d	150	mm	
Number of teeth	Z	60	-	
Pitch Ratio		50:50	%	
Material		ST37		

4 Package Information

4.1 Package and Packing Dimensions - TLE4941plusC

Pure tin covering (green lead plating) is used. Lead frame material is K62 (UNS: C18090) and contains CuSn1CrNiTi. Product is RoHS (restriction of hazardous substances) compliant when marked with letter G in front or after the data code marking and contains a data matrix code on the back side of the package (see also information note 136/03). Please refer to your key account team or regional sales if you need further information.

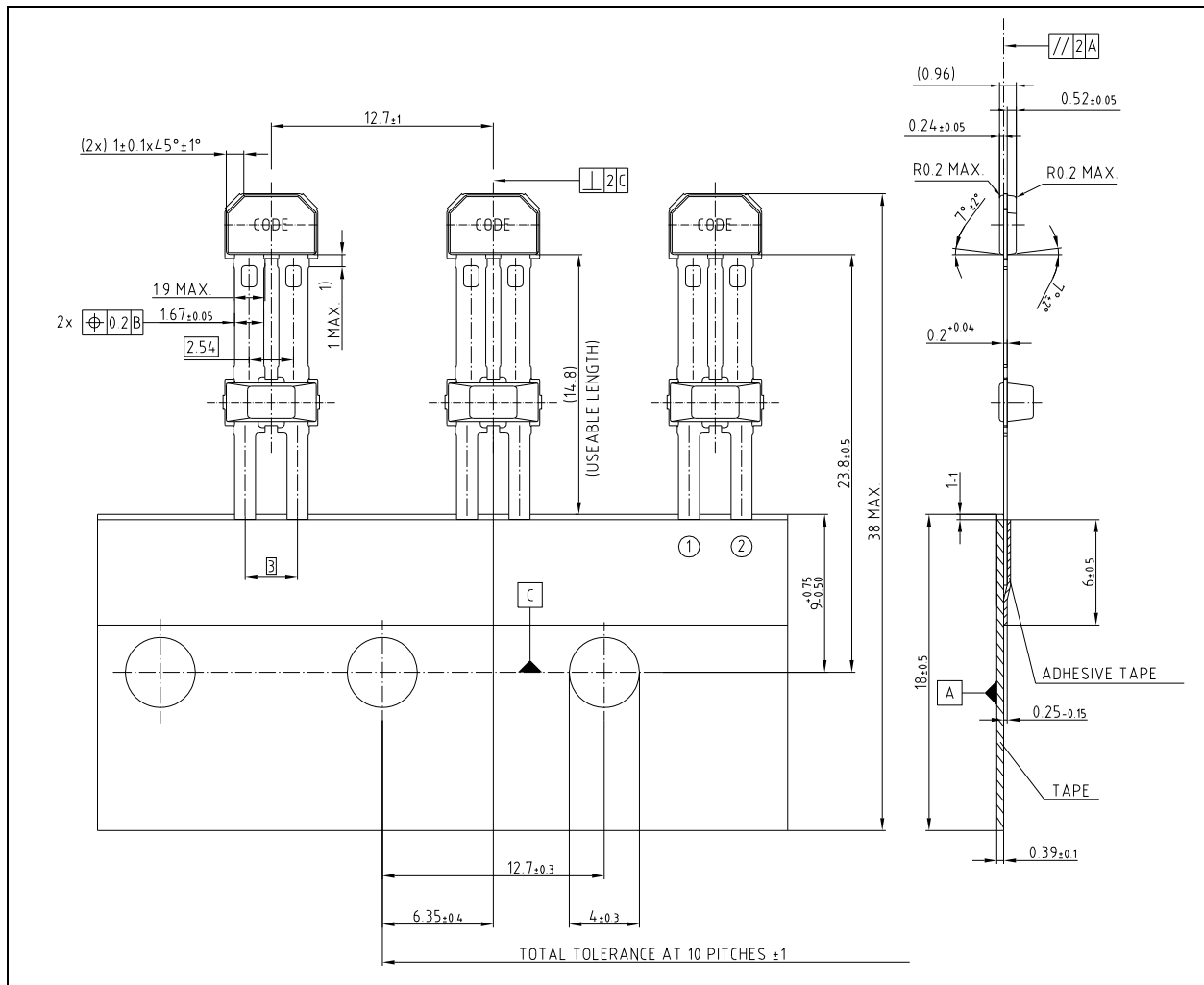

Figure 4-1 Package Dimensions of PG-SSO-2-53 (Plastic Green Single Small Outline)

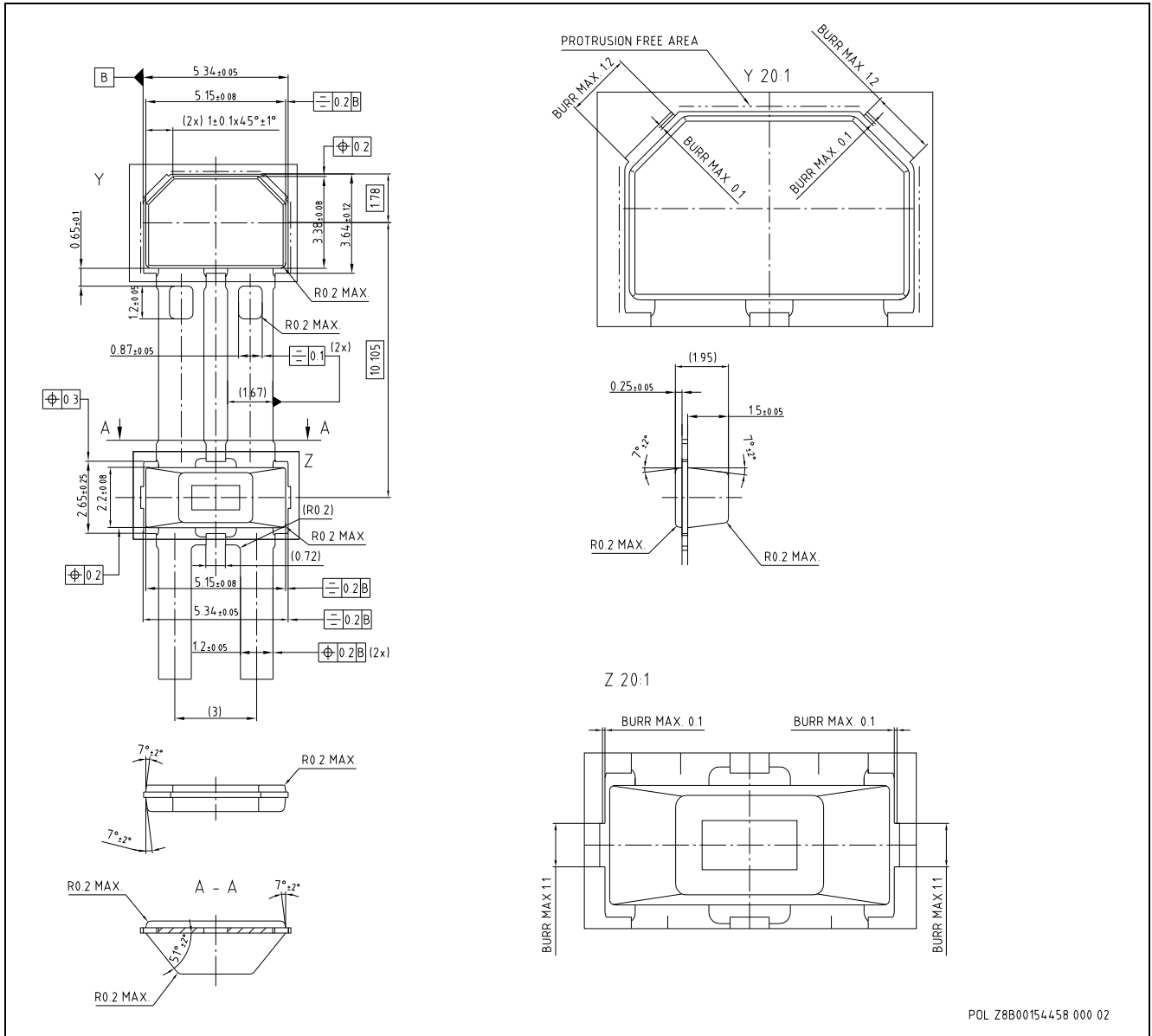

Figure 4-2 Package Dimensions in mm of PG-SSO-2-53 (Plastic Single Small Outline Package)

4.2 Package and Packing Dimensions - TLE4941plusCB

Product is RoHS (restriction of hazardous substances) compliant when marked with letter G in front or after the data code marking and contains a data matrix code on the back side of the package. Please refer to your key account team or regional sales if you need further information.

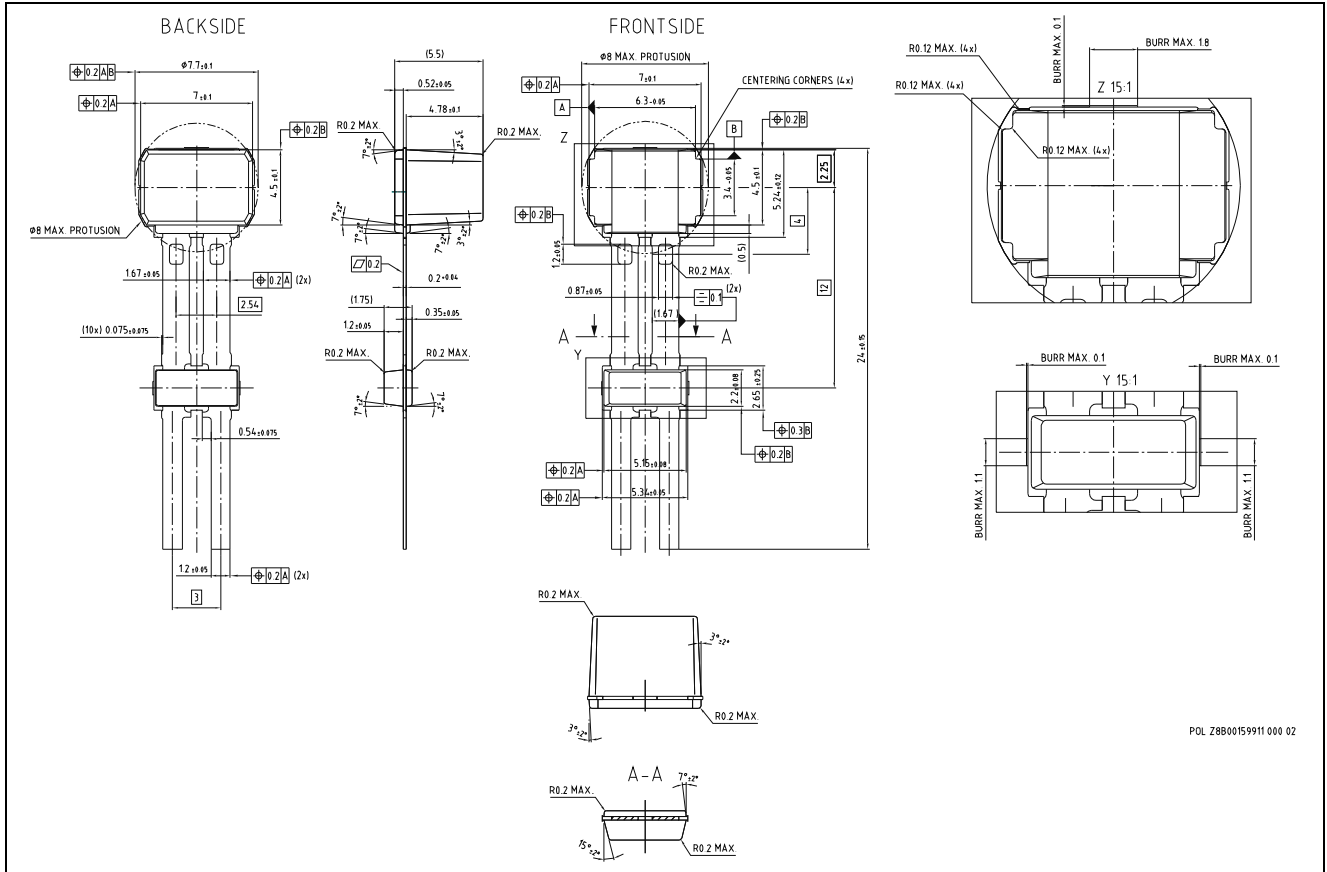

Figure 4-3 Package Outline Dimensions in mm of PG-SSOM-2-11

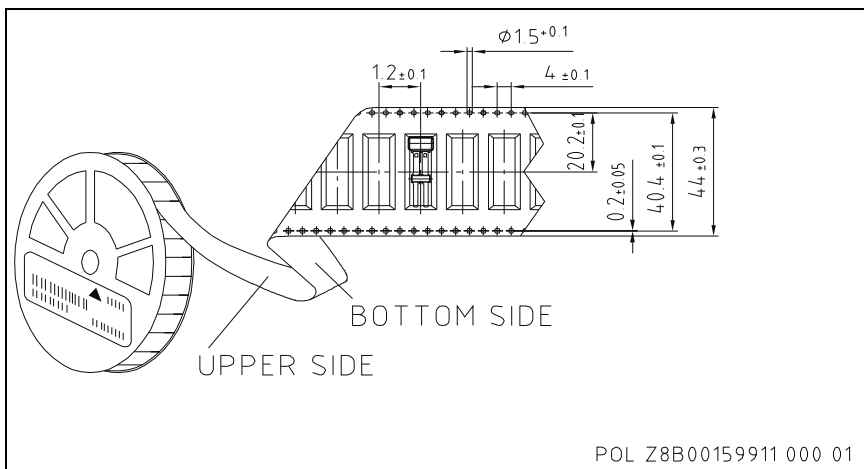

Figure 4-4 Packing dimensions of "Packing Blister Carrier Tape" in mm of PG-SSOM-2-11

For additional packages information, sort of packing and others, please see Infineon internet web page: <http://www.infineon.com/products>

Edition 2014-03-10

Published by
Infineon Technologies AG
81726 Munich, Germany
© 2014 Infineon Technologies AG
All Rights Reserved.

Legal Disclaimer

The information given in this document shall in no event be regarded as a guarantee of conditions or characteristics. With respect to any examples or hints given herein, any typical values stated herein and/or any information regarding the application of the device, Infineon Technologies hereby disclaims any and all warranties and liabilities of any kind, including without limitation, warranties of non-infringement of intellectual property rights of any third party.

Information

For further information on technology, delivery terms and conditions and prices, please contact the nearest Infineon Technologies Office (www.infineon.com).

Warnings

Due to technical requirements, components may contain dangerous substances. For information on the types in question, please contact the nearest Infineon Technologies Office. Infineon Technologies components may be used in life-support devices or systems only with the express written approval of Infineon Technologies, if a failure of such components can reasonably be expected to cause the failure of that life-support device or system or to affect the safety or effectiveness of that device or system. Life support devices or systems are intended to be implanted in the human body or to support and/or maintain and sustain and/or protect human life. If they fail, it is reasonable to assume that the health of the user or other persons may be endangered.

www.infineon.com

Published by Infineon Technologies AG