

XC164CM Series

The 16-bit Flash Microcontroller Family in PG-LQFP-64 Package



THE XC164CM series is the new family of the enhanced 16-bit microcontroller XC166 which offers impressive DSP performance and advanced interrupt handling combined with a powerful integrated peripheral set, high performance and reliable on-chip Flash memory.

THE XC164CM series gives embedded system designers the ability to scale memory, speed and peripherals. The tiny LQFP-64 pb-free package makes it fit to any industrial and automotive applications that require little board space and low cost.

THE FLEXIBLE and intelligent PWM unit simplifies control of AC-, DC- or reluctance motors. A high speed, high resolution ADC handles the fast and accurate translation of complex analog environment. Networked solutions can be confidently solved with powerful communication interfaces like the high speed TwinCAN module with autonomous gateway function.

THE XC164CM series is the logic successor of Infineon's successful C164 family. The migration path from C164 to XC164CM series is supported by the same basic architecture and instruction set, so a high level of reuse can be achieved.

Applications

- Automotive body & comfort
- Automotive safety
- Industrial motor control
- Consumer drives

Key Features

- High performance 16-bit C166S V2 CPU with 5-stage pipeline
- Single clock instruction execution with 25 ns instruction time at 40 MHz CPU clock
- 25 ns multiplication (16x16 bit), background division (32/16 bit), and multiply-and-accumulate (MAC) instructions
- Zero-cycle jump execution
- Register-based design with multiple variable register banks
- Fast context switch with two additional local register banks
- 16 Mbytes total linear address space for code and data
- 1024 Bytes on-chip SFR area (C166 family compatible)
- 16-priority-level interrupt system with up to 75 sources, sample rate down to 50 ns

- 8-channel interrupt-driven single-cycle data transfer facilities via peripheral event controller
- Clock generation via on-chip PLL or via prescaler
- 2 Kbytes on-chip dual-port RAM
- 2/4 Kbytes on-chip data SRAM
- 2 Kbytes on-chip program/data SRAM
- 32, 64 or 128 Kbytes on-chip program Flash (with Error Correction)
- 14-channel A/D converter with programmable resolution and conversion time down to 2.15 μ s (on versions -CM, -GM, -SM, -TM)
- One 16-channel general purpose capture/compare unit
- Capture/compare unit for flexible PWM signal generation (3/6 capture/compare channels and 1 compare channel), (on versions -CM, -SM)
- Multi-functional general purpose timer unit with 5 timers
- Two synchronous/asynchronous serial channels (USARTs)
- Two high-speed synchronous serial channels
- On-chip TwinCAN interface (Rev. 2.0B active) with 32 MO and gateway functionality (on versions -CM, -GM, -KM)
- On-chip real time clock
- Enhanced power saving modes with flexible power management
- Programmable watchdog timer and oscillator watchdog
- Up to 47 general purpose I/O
- On-chip bootstrap loader
- Supported by a large range of development tools
- On-chip debug support via JTAG interface
- PG-LQFP-64 pb-free package, 0.5 mm (19.7 mil) pitch
- Temperature range: -40°C to +125°C and -40°C to +85°C
- Supply Voltage:
 - Core Supply: 2.5 V
 - Port: 5 V

www.infineon.com/microcontrollers

Microcontrollers



Never stop thinking

Block Diagram

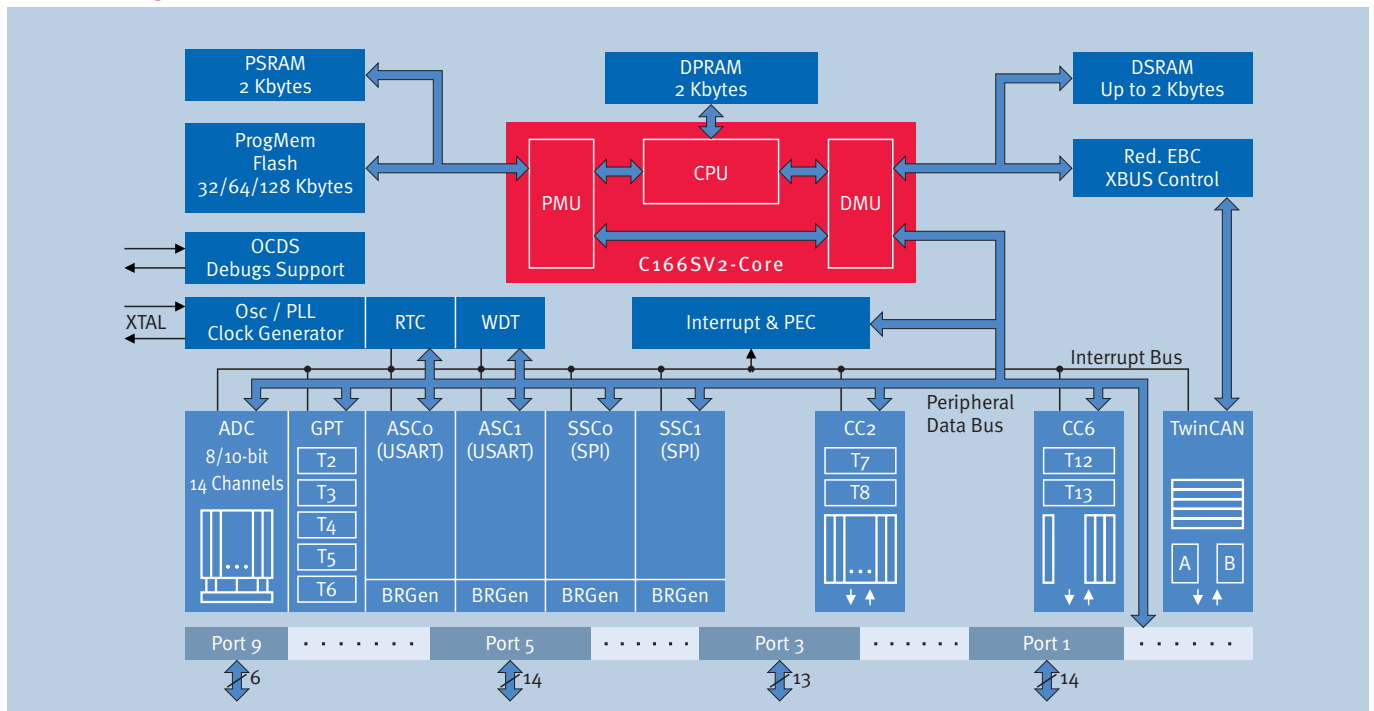

Product Summary

	XC164CM	XC164GM	XC164LM	XC164KM	XC164SM	XC164TM
eFlash [Kbytes]	32/64/128	32/64/128	32/64/128	32/64/128	32/64/128	32/64/128
RAM [Kbytes]	4/6/8	4/6/8	4/6/8	4/6/8	4/6/8	4/6/8
Package	PG-LQFP-64	PG-LQFP-64	PG-LQFP-64	PG-LQFP-64	PG-LQFP-64	PG-LQFP-64
Frequency [MHz]	20/40	20/40	20/40	20/40	20/40	20/40
Temperature Range [°C]	-40 ... 85 -40 ... 125	-40 ... 85	-40 ... 85	-40 ... 85	-40 ... 85	-40 ... 85
CAPCOM6(CC6)	✓	-	-	-	✓	-
TwinCAN	✓	✓	-	✓	-	-
A/D Converter	✓	✓	-	-	✓	✓

Application Example

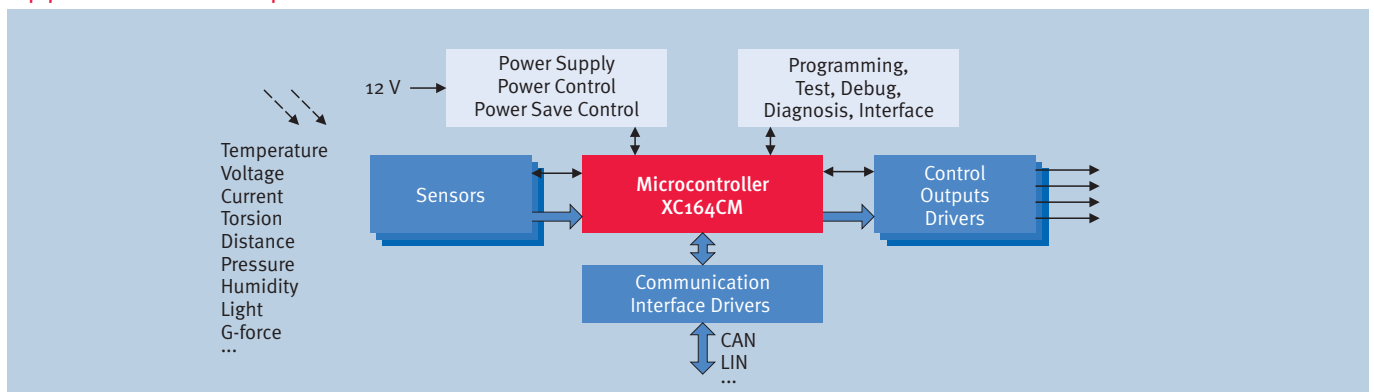

How to reach us:
<http://www.infineon.com>

Published by
 Infineon Technologies AG
 81726 München, Germany

© Infineon Technologies AG 2006.
 All Rights Reserved.

Legal Disclaimer

The information given in this Product Brief shall in no event be regarded as a guarantee of conditions or characteristics ("Beschaffenheitsgarantie"). With respect to any examples or hints given herein, any typical values stated herein and/or any information regarding the application of the device, Infineon Technologies hereby disclaims any and all warranties and liabilities of any kind, including without limitation warranties of non-infringement of intellectual property rights of any third party.

Information

For further information on technology, delivery terms and conditions and prices please contact your nearest Infineon Technologies Office (www.infineon.com).

Warnings

Due to technical requirements components may contain dangerous substances. For information on the types in question please contact your nearest Infineon Technologies Office.

Infineon Technologies Components may only be used in life-support devices or systems with the express written approval of Infineon Technologies, if a failure of such components can reasonably be expected to cause the failure of that life-support device or system, or to affect the safety or effectiveness of that device or system. Life support devices or systems are intended to be implanted in the human body, or to support and/or maintain and sustain and/or protect human life. If they fail, it is reasonable to assume that the health of the user or other persons may be endangered.

Ordering No. B158-H8386-G3-X-7600
 Printed in Germany
 PS 0606 nb