

## MLVS 0603 Lead Free Series

# Specification

Product Name	Multilayer Varistor
Series	MLVS Lead Free Series
Size	EIA 0603



### 3. Construction & Dimension

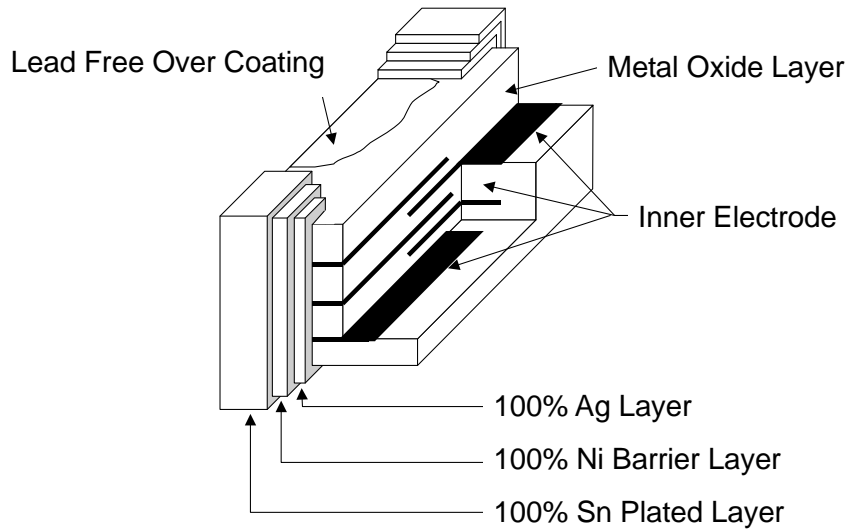
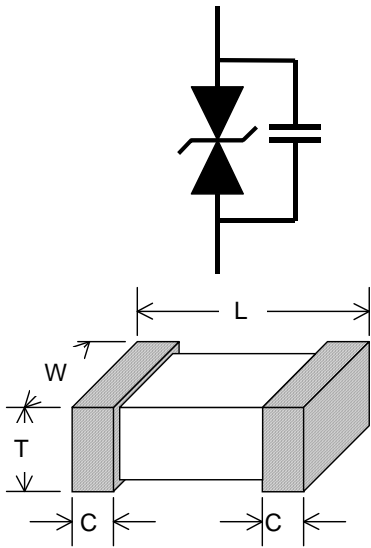

Unit: mm	0603
L	1.60±0.15
W	0.80±0.1
T	0.80±0.1
c	0.30±0.20

## 4. Part ratings and characteristics:

### 4.1. Rating(25±5°C)

Symbol	Working voltage		Varistor voltage	Clamping Voltage	Capacitance	Peak current	Transient energy
	$V_{RMS}$	$V_{DC}$	$V_V$	$V_c$	$C_p$	$i_{max}$	$W_{max}$
Units	Volts	Volts	Volts	Volts	pF	Amps	Joules
Test Condition		(Max.)		(Max.)			
		$< 10 \mu A$	1mA DC	1A 8/20 $\mu s$	1MHz	8/20 $\mu s$	10/1000 $\mu s$
MLVS 0603 L04	4	5.5	8 ~ 18	24	270	30	0.1
MLVS 0603 L07	7	9	11.5 ~ 21.5	41	210	30	0.1
MLVS 0603 L14	14	18	23 ~ 33	54	150	30	0.1
MLVS 0603 L20	20	26	32 ~ 42	70	100	30	0.1
MLVS 0603 LE08	-	12	25 ~ 40	110	40	-	-
MLVS 0603 LE10	-	12	45 ~ 65	150	3.5	-	-
MLVS 0603 LE12	-	26	45 ~ 65	145	4	-	-

$V_{RMS}$  – Maximum AC operating voltage the varistor can maintain and not exceed 10 $\mu$ A leakage current

$V_{DC}$  – Maximum DC operating voltage the varistor can maintain and not exceed 10 $\mu$ A leakage current

$V_V$  – Voltage across the device measured at 1mA DC current.  
Equivalent to  $V_b$ , “Breakdown Voltage”.

$C_p$  – Device capacitance measured with zero volt bias 1Vrms at 1MHz.

$V_c$  – Maximum peak voltage across the varistor measured at 8/20us waveform and 1A pulse current

$i_{max}$  – Maximum peak current which may be applied with 8/20us waveform without device failure

$W_{max}$  – Maximum energy that may be dissipated with the 10/1000us waveform without device failure

## 5. General electrical specifications

### 5.1. General technical data

Operating temperature	-40 ... +85°C
Storage temperature (on board)	-40... +85°C
Response time	<1 ns
Solderability	245±5°C, 5+0/ -0.5sec
Solder leach resistance	260±5°C, 10 ±1sec

### 5.2. Environmental Specifications

Characteristics	Specifications	Test condition
Bias humidity	$\Delta V_V / V_V \leq \pm 10\%$	90%RH, 40°C, Working voltage, 1000 hours
Thermal shock	$\Delta V_V / V_V \leq \pm 10\%$	-40°C to 85°C, 30 min. Cycle, 5 cycles
Full load voltage	$\Delta V_V / V_V \leq \pm 10\%$	Working voltage, 85°C, 1000 hours

### 5.3. Storage Condition with package

Storage Time: 12 months max

Storage Temperature : 5 to 40°C

Relative Humidity: to 65 %

## 6. Taping Package and Label Marking

### 6.1. Carrier tape dimensions

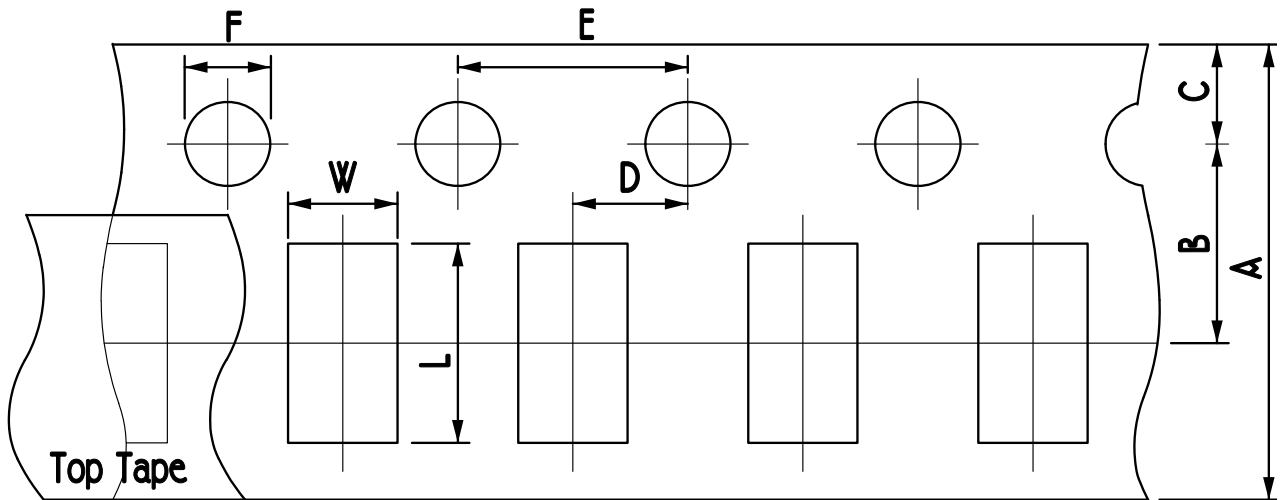

UNIT: mm

A	B	C	D	E	F	L	W
8.00± 0.30	3.50± 0.05	1.75± 0.10	2.00± 0.05	4.00± 0.10	1.50± 0.10	1.90± 0.15	1.05± 0.15

### 6.2. Taping reel dimensions

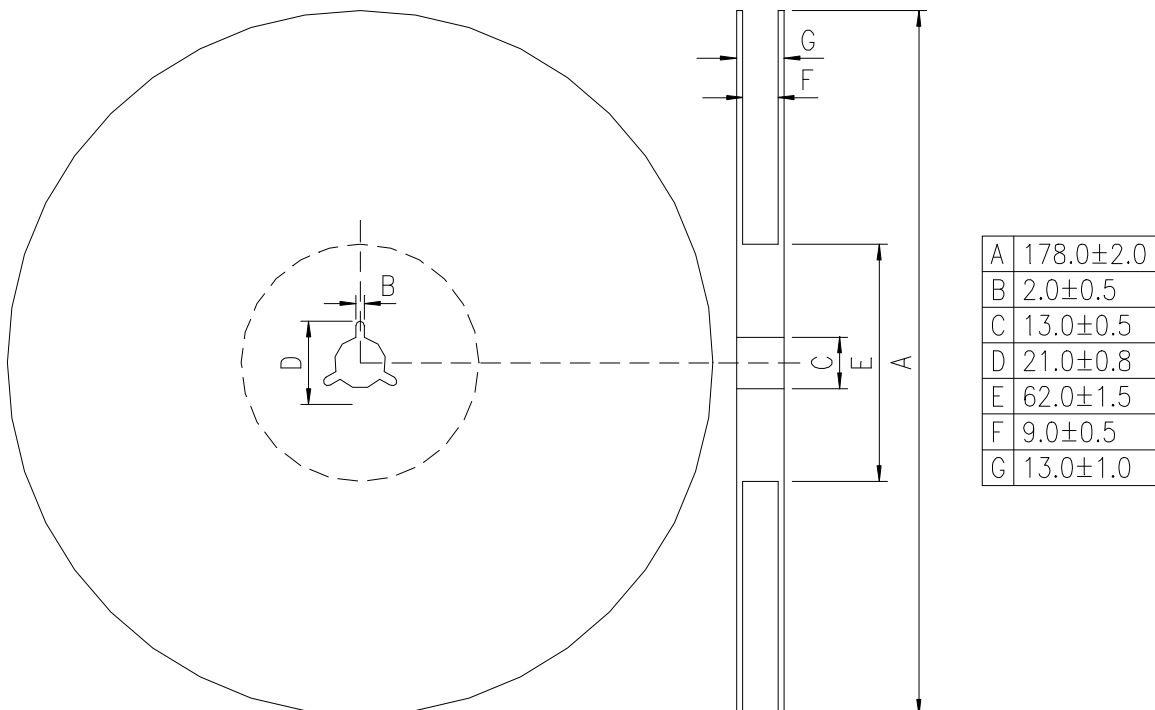

### 6.3. Taping specifications

There shall be the portion having no product in both the head and the end of taping, and there shall be the cover tape in the head of taping.

### 6.4. Label Marking

The label specified as follows shall be put on the side of reel.

- (1) Part No.
- (2) Quantity
- (3) Lot No.

\* Part No. And Quantity shall be marked on outer packaging.

### 6.5. Quantity of products in the taping package

- (1) Standard quantity: 4000pcs/Reel for MLVS 0603 Lead Free series
- (2) Shipping quantity is a multiple of standard quantity.

## 7. Precautions for Handling

### 7.1. Solder cream in reflow soldering

Refer to the recommendable land pattern as printing mask pattern for solder cream.

- (1) Print solder in a thickness of 150 to 200  $\mu\text{m}$ .
- (2) Dimensions: millimeters (inches)

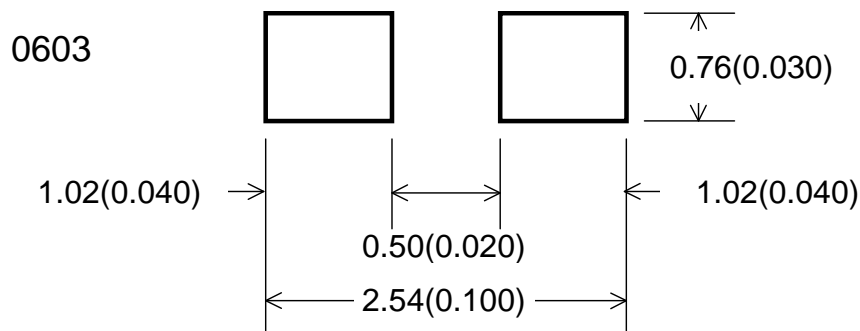

### 7.2. Precaution for handling of substrate

Do not exceed to bend the board after soldering this product extremely.

(Reference examples)

- Mounting place must be as far as possible from the position, which is close to the break line of board, or on the line of large holes of board.
- Do not bend extremely the board, in mounting another components.  
If necessary, use back-up pin (support pin) to prevent from bending extremely.
- Do not break the board by hand. We recommend using the machine or the jig to break it.

### 7.3. Precaution for soldering

Note that rapid heating, rapid cooling or local heating will easily damage this product.

Do not give heat shock over 100°C in the process of soldering. We recommend taking preheating and gradual cooling.

### 7.4. Recommendable reflow soldering

Profile Feature	Pb-Free Assembly
Average Ramp-Up Rate (T <sub>smax</sub> to T <sub>p</sub> )	3° C/second max.
<b>Preheat</b> – Temperature Min (T <sub>smin</sub> ) – Temperature Max (T <sub>smax</sub> ) – Time (t <sub>smin</sub> to t <sub>smax</sub> )	150 °C 200 °C 60-180 seconds
Time maintained above: – Temperature (T <sub>L</sub> ) – Time (t <sub>L</sub> )	217 °C 60-150 seconds
Peak/Classification Temperature (T <sub>p</sub> )	260 °C
Time within 5 °C of actual Peak Temperature (t <sub>p</sub> )	20-40 seconds
Ramp-Down Rate	6 °C/second max.
Time 25 °C to Peak Temperature	8 minutes max.



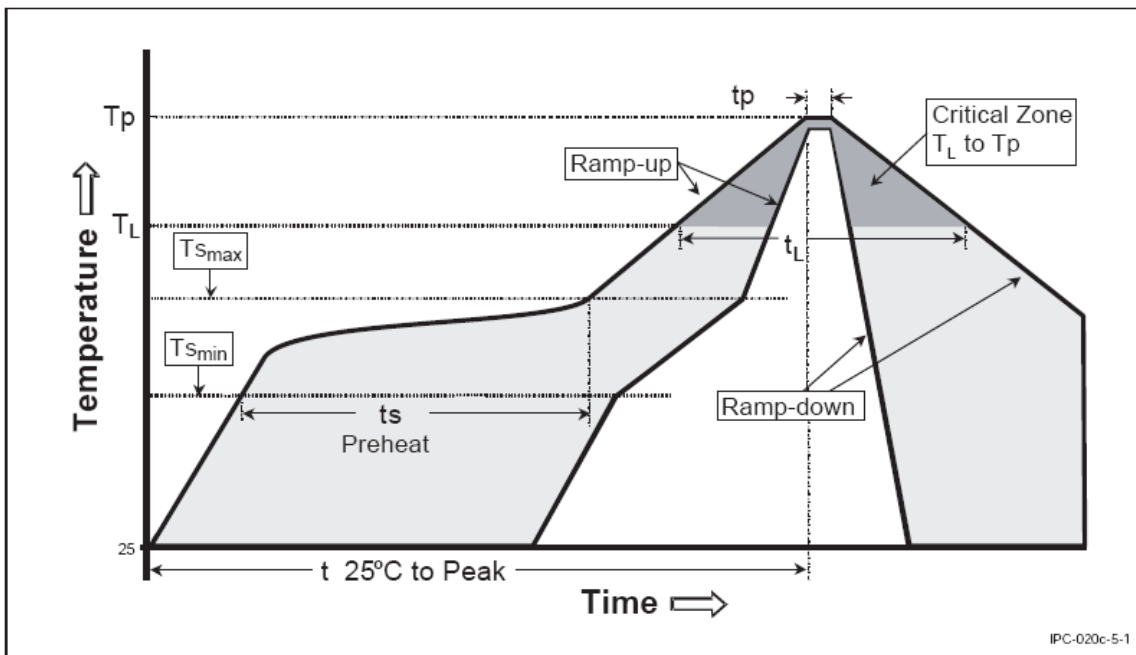

\*According to J-STD-020C

### 7.5. Soldering gun procedure

Note the follows, in case of using solder gun for replacement.

- (1) The tip temperature must be less than 350°C for the period within 3 seconds by using soldering gun less than 30 W.
- (2) The soldering gun tip shall not touch this product directly.

### 7.6. Soldering volume

Note that excess of soldering volume will easily get crack the body of this product.