

HR2220V801R-10

UNCONTROLLED DOCUMENT

PHYSICAL DIMENSIONS:

A	5.59 [.220]	+ 0.51 [.020]
B	5.08 [.200]	+ 0.25 [.010]
C	3.61 [.142]	+ 0.25 [.010]
D	0.76 [.030]	+ 0.25 [.010]

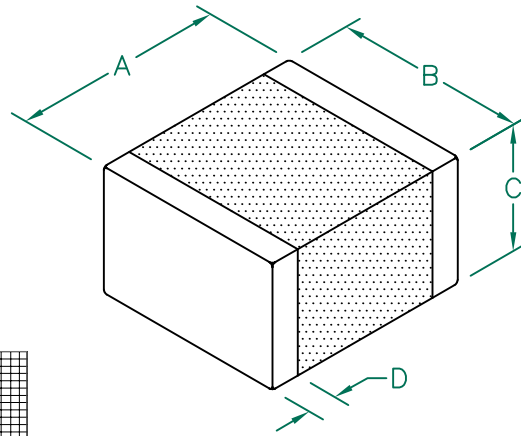

ELECTRICAL CHARACTERISTICS:

Z @ 100 MHz (Ω)	DCR (Ω)	Rated Current
Nominal	800	
Minimum	600	
Maximum	1000	0.010 8000 mA

NOTES: UNLESS OTHERWISE SPECIFIED

1. TAPED AND REELED per CURRENT EIA SPECIFICATIONS 13" REELS, 2,000 PCS/REEL.
2. U.S. PATENT 6,249,205B1 SHOULD APPEAR ON THE LABEL OF EACH REEL OF PACKAGED PARTS.
3. TERMINATION FINISH IS 100% TIN.
4. COMPONENTS SHOULD BE ADEQUATELY PREHEATED BEFORE SOLDERING.
5. OPERATEING TEMPERATURE TEMP: -40°C~+125°C (INCLUDING SELF-HEATING)

Z vs FREQUENCY
IMPEDANCE UNDER DC BIAS

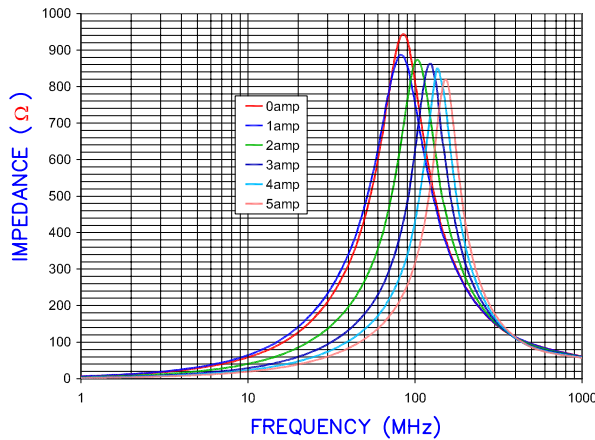

|Z|, R, AND X vs. FREQUENCY

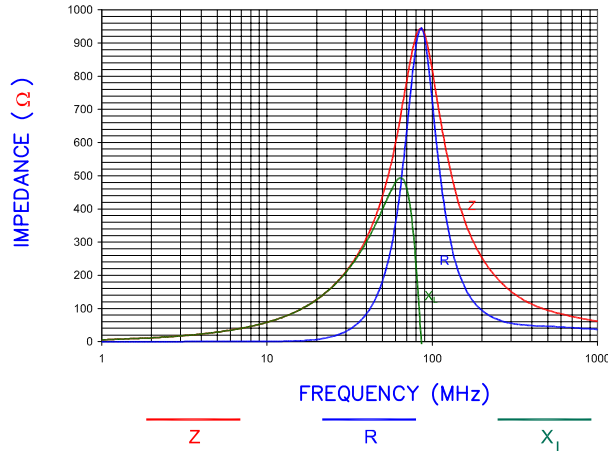

LAND PATTERNS FOR REFLOW SOLDERING

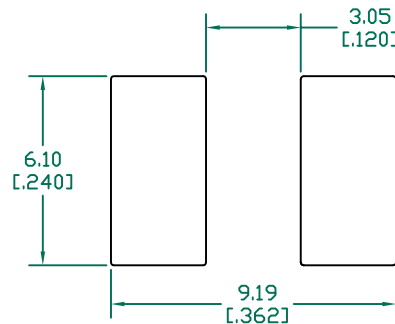

(For wave soldering, add 0.762 [.030] to this dimension.)

RECOMMENDED SOLDERING CONDITIONS

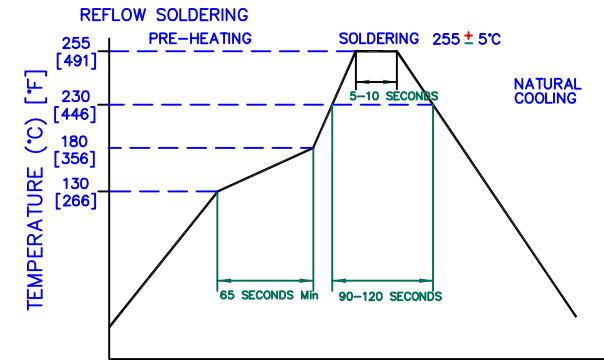

DIMENSIONS ARE IN mm [INCHES].				This print is the property of Laird Tech. and is loaned in confidence subject to return upon request and with the understanding that no copies shall be made without the written consent of Laird Tech. All rights to design or invention are reserved.			
				Laird			
				PROJECT/PART NUMBER: HR2220V801R-10			
C ADD OPERATING TEMPERATURE UPDATE LAIRD LOGO AND REFLOW CURVE 08/05/13 QU				REV: C		PART TYPE: CO-FIRE	DRAWN BY: QU
B UPDATE COMPANY LOGO ADD ROHS 02/14/08		JRK DATE: 08/05/13		SCALE: NTS		SHEET: 2 of 2	
A ORIGINAL DRAFT 04/03/04		TMB		TOOL # -			
REV DESCRIPTION DATE INT				CAD # HR2220V801R-10-C			