



The Future of Analog IC Technology®

MagAlpha MA750

Contactless Turning Knob Sensor

PRELIMINARY SPECIFICATIONS SUBJECT TO CHANGE

DESCRIPTION

The MagAlpha MA750 is a robust, contactless, angle encoder suitable for control buttons and knobs. The IC detects the absolute angular position of a permanent magnet, typically a diametrically magnetized cylinder attached to the rotor.

The output is digital (SPI) or pulse-width modulation (PWM). For usual potentiometer replacement, the PWM signal can be filtered to obtain an analog signal.

Please See Position Sensor Design Support for All Supporting Software

FEATURES

- 8-Bit Digital and 12-Bit PWM Output
- 500kHz Refresh Rate
- 7.5mA Supply Current
- Serial Interface for Data Readout and Settings

APPLICATIONS

- Potentiometer Replacement
- Knobs
- Dials
- Appliances
- Consumer Goods

All MPS parts are lead-free, halogen-free, and adhere to the RoHS directive. For MPS green status, please visit the MPS website under Quality Assurance. "MPS" and "The Future of Analog IC Technology" are registered trademarks of Monolithic Power Systems, Inc.

TYPICAL APPLICATION

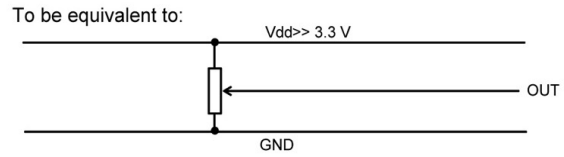
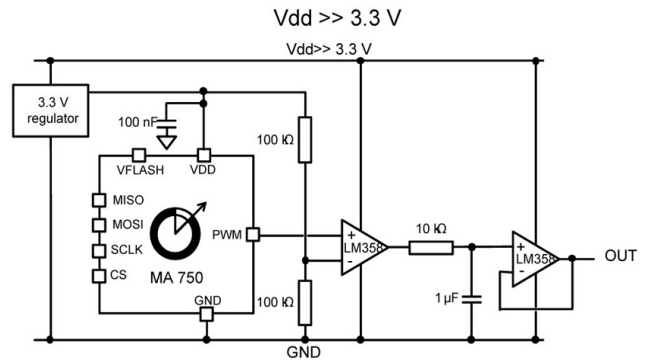
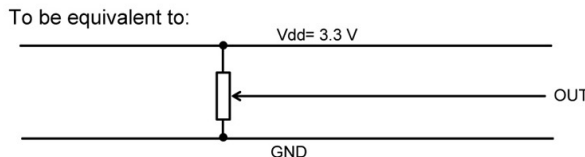
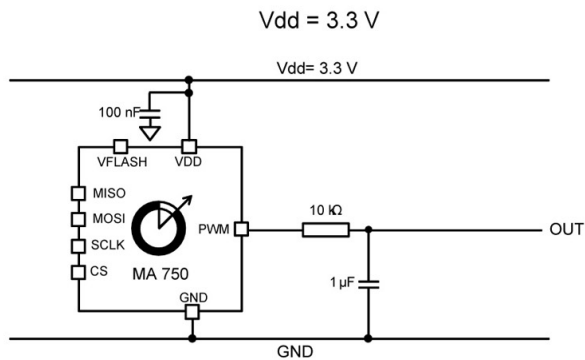

ORDERING INFORMATION

Part Number*	Package	Top Marking
MA750GQ	QFN-16 (3mmx3mm)	See Below

* For Tape & Reel, add suffix -Z (e.g. MA750GQ-Z)

TOP MARKING

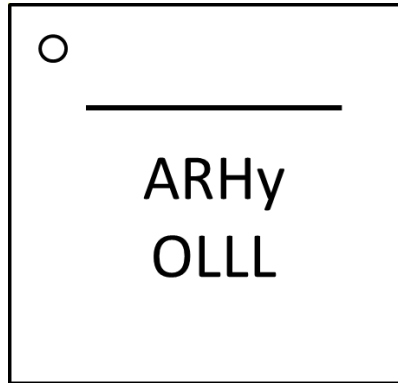

y: Year code
 O: Optional marking
 LLL: Lot number

PACKAGE REFERENCE

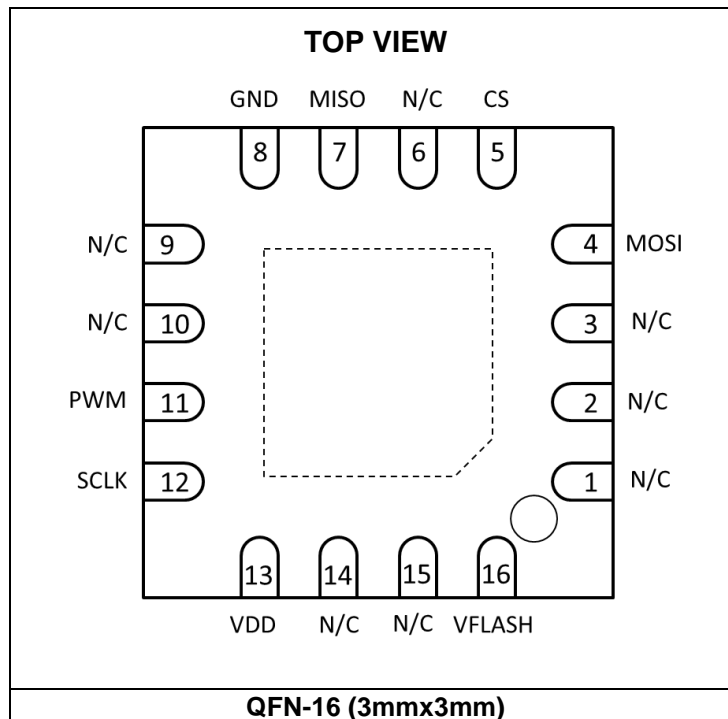

ABSOLUTE MAXIMUM RATINGS ⁽¹⁾

Supply voltage (continuous)..... -0.5V to +3.8V
Supply voltage short term -0.5V to +4.1V
I/O pin voltage -0.5V to 3.8V
Continuous power dissipation ($T_A = +25^{\circ}\text{C}$)⁽²⁾
.....2.5W

Thermal Resistance ⁽³⁾ θ_{JA} θ_{JC}
QFN-16 (3mmx3mm).....50..... 12... °C/W

NOTES:

- 1) Exceeding these ratings may damage the device.
- 2) The maximum allowable power dissipation is a function of the maximum junction temperature T_J (MAX), the junction-to-ambient thermal resistance θ_{JA} , and the ambient temperature T_A . The maximum allowable continuous power dissipation at any ambient temperature is calculated by P_D (MAX) = $(T_J$ (MAX)- T_A)/ θ_{JA} .
- 3) Measured on JESD51-7, 4-layer PCB.

ELECTRICAL CHARACTERISTICS

Parameter	Symbol	Condition	Min	Typ	Max	Units
Operating Conditions						
Supply voltage	VDD		3.0	3.3	3.6	V
Supply voltage for OTP flashing	V _{flash}		3.9	4.0	4.1	V
Supply current for OTP flashing ⁽⁴⁾	I _{flash}		50		100	mA
Operating temperature	Top		-40		125	°C
Applied magnetic field	B		30	75		mT

NOTE:

4) Please see the OTP Programming section for more details about the supply circuits for OTP flashing.

ELECTRICAL CHARACTERISTICS (continued)
VDD = 3.3V, 50mT < B < 100mT, temp = -40°C to +125°C, unless otherwise noted.

Parameter	Symbol	Condition	Min	Typ	Max	Units
Sensor Output Specifications						
Power-up time ⁽⁵⁾				2	3	ms
Supply current			6.0	7.7	8.8	mA
INL at 25°C		At room temperature over the field range	±0.9	±1.6	±2.0	deg
INL between -40°C to +125°C ⁽⁵⁾		The largest value over the temperature range and field range	±0.5	±1.6	±2.5	deg
Output Drift						
Temperature induced ⁽⁵⁾			-0.026		+0.026	deg/°C
Magnetic field induced ⁽⁵⁾			-0.023		+0.023	deg/mT
Voltage supply induced ⁽⁵⁾			-0.7		+0.7	deg/V
Absolute Output – Serial						
Data output length			8		8	bit
Refresh rate			488	524	558	kHz
Latency ⁽⁶⁾		Measured at constant speed		3		µs
Resolution (3σ noise level)		Measured by averaging over all angles	8.0		8.0	bit
Absolute Output – PWM						
Resolution (3σ noise level)			12		12	bit
Digital I/O						
Threshold voltage high				1.75		V
Threshold voltage low				1.05		V
Rising edge slew rate		CL = 50pF		0.7		V/ns
Falling edge slew rate		CL = 50pF		0.7		V/ns
OTP Flash Timing						
Flashing time for one register ⁽⁶⁾					2.6	ms
Period for multiple registers flashing ⁽⁶⁾		Time between 2 successive flash commands	2.6			ms

NOTES:

- 5) Guaranteed by design.
6) Guaranteed by characteristic test.

TYPICAL CHARACTERISTICS

VDD = 3.3V, temp = 25°C, unless otherwise noted

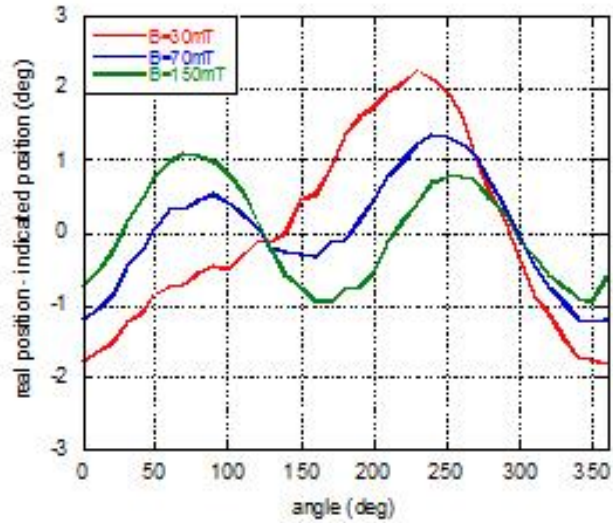

PIN FUNCTIONS

Package Pin #	Name	Description
1, 2, 3, 6, 9, 10, 14, 15	NC	No connection. Leave unconnected.
4	MOSI	Data in. Serial.
5	CS	Chip select. Serial.
7	MISO	Data out. Serial.
8	GND	Ground.
11	PWM	PWM output.
12	SCSL	Clock. Serial.
13	VDD	3.3V supply.
16	VFLASH	4.0V supply for OTP flashing. Leave unconnected if not used.

BLOCK DIAGRAM

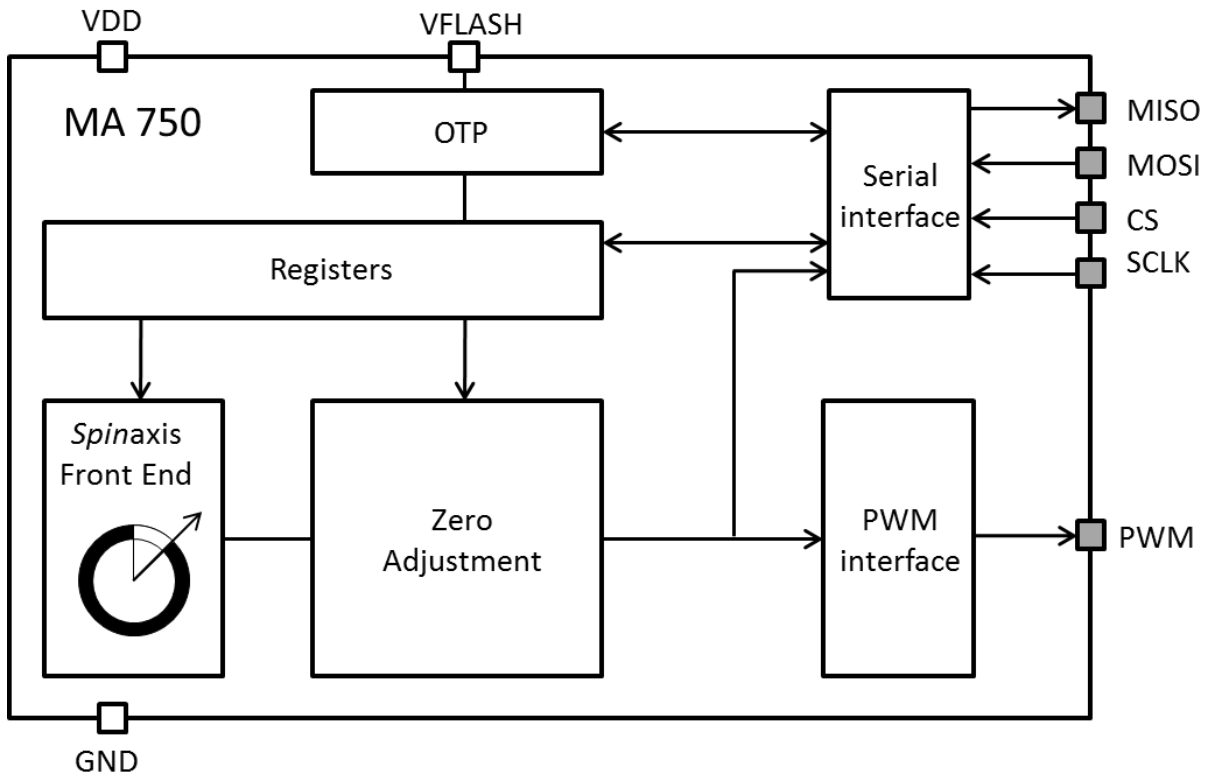

Figure 1: Functional Block Diagram

OPERATION

Timing of the Serial Interface

The data link is a 4-wire serial bus complying with the serial peripheral interface (SPI) usual convention (see Table 1 and Table 2). The MagAlpha sensor operates as a slave. During one transmission, a 16-bit word can be sent to the sensor MOSI and received from the sensor MISO simultaneously (see Figure 2).

Table 1: SPI Specification

SCLK idle state	High
SCLK readout edge	Rising
CS idle state	High
Data order	MSB first

Table 2: SPI Standard

CPOL	1
CPHA	1
MODE	3
DORD	0

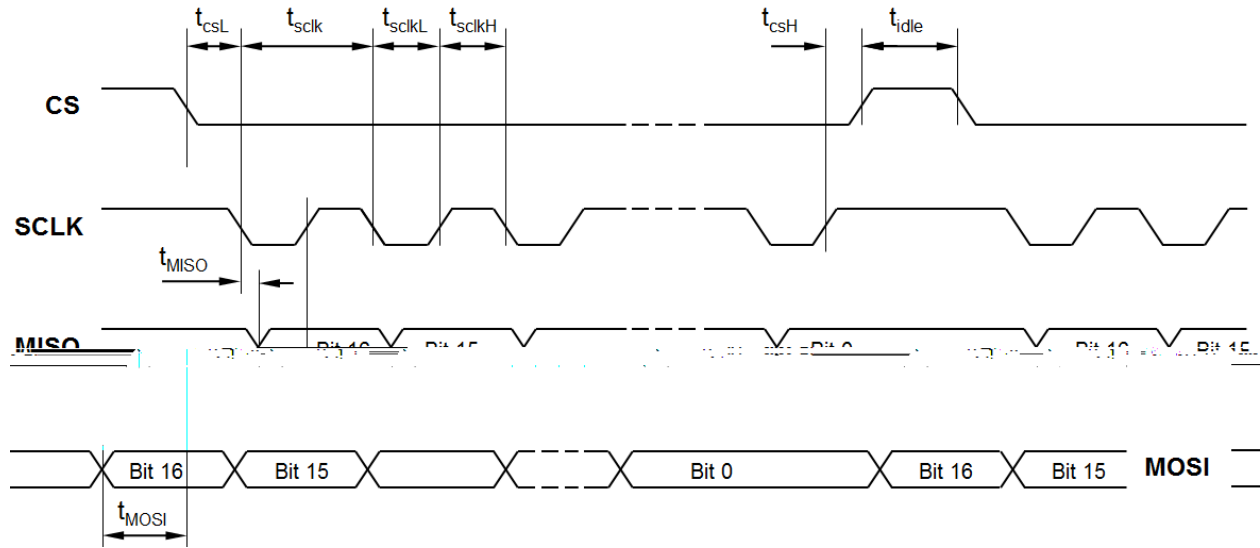

Figure 2: SPI Timing Diagram

Table 3: SPI Timing

Parameter	Description	Min	Max	Unit
t _{idle}	Time between two subsequent transmissions	50		ns
t _{csL}	Time between CS falling edge and SCLK falling edge	50		ns
t _{sclk}	SCLK period	40		ns
t _{sclkL}	Low level of SCLK signal	20		ns
t _{sclkH}	High level of SCLK signal	20		ns
t _{csH}	Time between SCLK rising edge and CS rising edge	25		ns
t _{MOSI}	Data input valid to SCLK reading edge	15		ns
t _{MISO}	SCLK setting edge to data output valid		15	ns

Registers

Table 4: Register Map

No	Hex	Bin	Bit 7 MSB	Bit 6	Bit 5	Bit 4	Bit 3	Bit 2	Bit 1	Bit 0 LSB
4	0x4	0100	Z(7:0)							
9	0x9	1001	-	-	-	F4	-	-	-	-

Table 5: Programming Parameters

Parameters	Symbol	Number of Bits	Description	See Table
Zero setting	Z	8	Sets the zero position with resolution of 360/256 deg per bit ~ 1.41 deg.	6
Flash register <i>n</i>	<i>F_n</i>	1	Flash the content of register number <i>n</i> .	

Sensor – Magnet Mounting

The sensitive volume of the MA750 is confined in a region less than 100µm wide and has multiple integrated Hall devices. This volume is located both horizontally and vertically within 50µm of the center of the QFN package. The sensor detects the angle of the magnetic field projected in a plane parallel to the package's upper surface. This means that the only relevant magnetic field is the in-plane component (X and Y components) in the middle point of the package.

Rotation Direction

Looking at the MagAlpha top, the angle increases when the magnetic field rotates clockwise. Figure 3 shows the zero angle of the unprogrammed MA750, where the cross indicates the sensitive point.

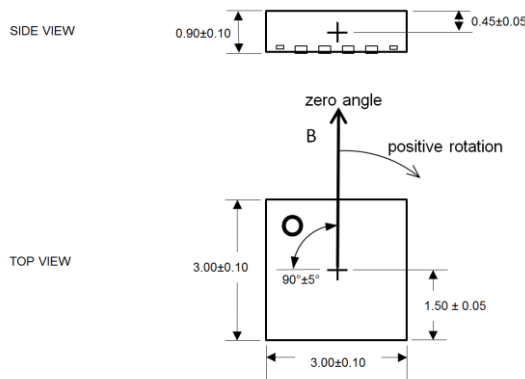

Figure 3: Zero Angle of Unprogrammed MA750

This type of detection provides flexibility for the design of an angular encoder. The sensor only requires the magnetic vector to lie essentially within the sensor plane with an amplitude of at least 30mT. Note that the MA750 can work with fields smaller than 30mT, but the linearity and resolution performance may deviate from the specifications. The straightforward solution is to place the MA750 sensor on the rotation axis of a permanent magnet (i.e.: a diametrically magnetized cylinder) (see Figure 4).

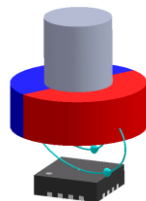

Figure 4: End-of-Shaft Mounting

Mounting and Power Supply Decoupling

For most applications, a single 100nF bypass capacitor placed close to the supply pins decouples the MA750 from power supply noise. If better decoupling is required, a larger capacitor (i.e.: 1µF to 10µF) can be added in parallel with the 100nF capacitor, and/or a serial resistor (i.e.: 10Ω) can be added on the supply line. Ensure that the capacitor is connected with low impedance paths.

VFLASH needs to be supplied only when flashing the memory. Otherwise, VFLASH can remain unconnected (see Figure 5).

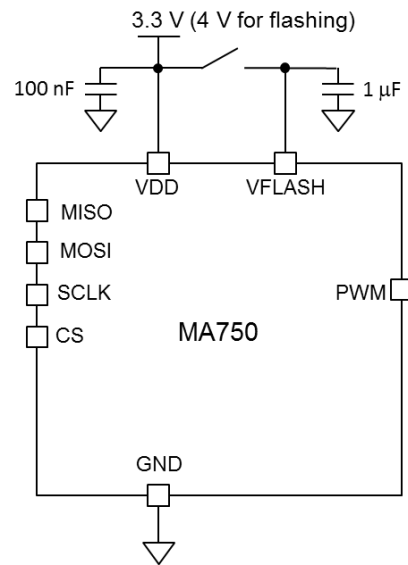

Figure 5: Connection for Supply Decoupling

The package's exposed pad can be soldered to the PCB to ensure optimum electrical, thermal, and mechanical conditions. In case the exposed pad is soldered, it is recommended to connect the pad to ground electrically.

Sensor Front-End

The magnetic field is detected with integrated Hall devices located in the center of the package. The angle is measured using the *spinaxis* method, which directly digitizes the direction of the field without any arctangent computation or feedback loop-based circuit (interpolators, etc.).

The *spinaxis* method is based on phase detection. It requires sensitive circuitry that generates a sinusoidal signal with a phase that represents the angle of the magnetic field. The angle is then retrieved by a time-to-digital converter, which counts the time between the zero crossing of the sinusoidal signal and the edge of a constant waveform (see Figure 6). The digitized time is the front-end output.

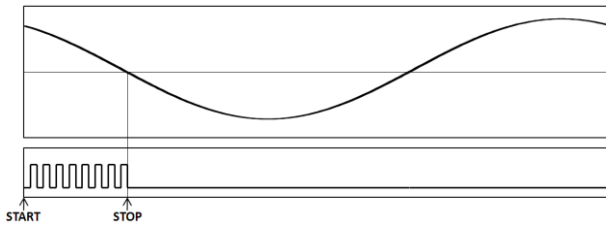

Top: Sine Waveform
 Bottom: Clock of Time-to-Digital Converter
Figure 6: Phase Detection Method

At the output, the front-end delivers a digital number proportional to the angle of the magnetic field at the rate of 500kHz in a straightforward and open-loop manner.

Zero Setting

The zero position of the MagAlpha (a_0) can be programmed with 8 bits of resolution (1.40625 deg per bit). The angle streamed out (a_{out}) can be calculated with Equation (1):

$$a_{out} = a_{fe} - a_0 \quad (1)$$

Where a_{fe} is the raw angle out of the front end.

The parameter Z(7:0), which is 0 by default, determines a_0 (see Table 6).

Table 6: Zero Position

Z(7:0)	Zero position a_0 (deg)
0	0
1	1.41
...	...
255	358.59

Programming the MA750

The MA750 incorporates two programmable registers. Each register has 8 bits of memory. When the MA750 is powered up, each of these three 8 bits of memory are set to zero, unless the register was previously stored in the one-time programmable (OTP) memory. This means that during start-up, the content of the OTP

memory is copied to the registers. Once flashed, the register content can no longer be modified.

To set the content of a register, a digital stream must be sent to the register consisting of the 4-bit register/write command (0010), a 4-bit register address, and the 8-bit value.

The data stream, sent through the MOSI wire is a total of 16 bits long:

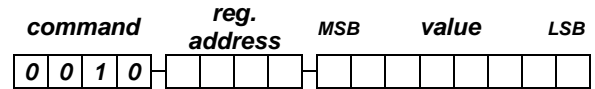

Once the command is sent, it is effective immediately and affects the next data sent from the MagAlpha.

Reading Back the Register Content

To check the content of a register to verify that the programming was successful, first send the register/read command (0001) and the 4-bit address of the register being tested. The last 8 bits of the stream are irrelevant. For instance, the value 0000 0000 can be sent:

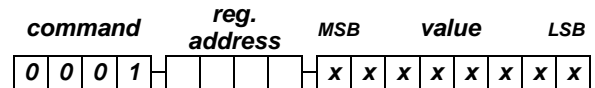

The MagAlpha response is within the same transmission. In the first byte (simultaneous to the 4-bit read command and the 4-bit address), the MagAlpha sends the 8 bits of the measured angle A(7:0). The second byte is the content of the register being tested. After this transmission, the MagAlpha continues delivering 8-bit angles A(7:0).

For example, to check the content of the register 4 (0100), which contains the zero setting, send the data:

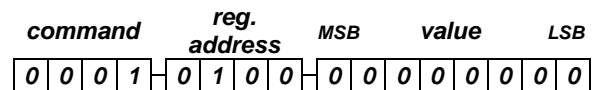

Simultaneously, the MagAlpha replies:

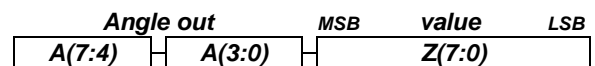

Output Signals

The raw data coming out of the conditioning blocks is an absolute angle between 0 and 360 deg. This angle is coded on 8 bits, depending on the value of AF. The absolute output is sent out as serial data digitally. The PWM output is constructed from the absolute angles.

Absolute – Signal

The bit order of the transmitted data is MSB first and LSB last. Every 2µs, new data is transferred into the output buffer. The master device connected to the MagAlpha triggers the reading by pulling CS down. When a CS falling edge signal occurs, the data remains in the output buffer until the CS signal returns to logic 1. When CS is low, the master can read the data by sending clock pulses with a maximum frequency of 25MHz.

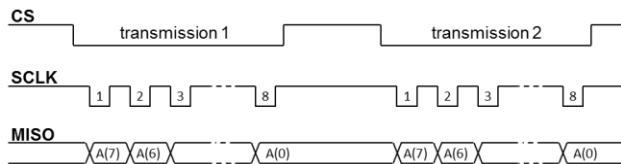
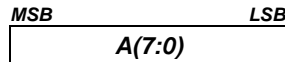

Figure 7: Timing Diagram for Simple SPI Readout

A full reading requires 8 clock pulses. The MA750 delivers:



If the master triggers the reading faster than the refresh rate, the MagAlpha may send the same data point several times.

Absolute - PWM

This output provides a logic signal with a duty cycle proportional to the angle of the magnetic field. The PWM frequency is close to 15.3 kHz (the nominal period is 65µs). The duty cycle is bounded by a minimum value (1/34 of the period) and a maximum value (33/34 of the period) (see Figure 8). This means that the duty cycle varies from 1/34 to 33/34 with a resolution of 12 bits. The angle can be retrieved by measuring the on time.

Since the absolute PWM frequency can vary from chip to chip or with the temperature, accurate angle detection requires the measurement of the duty cycle (i.e.: the measurement of both the on time (t_{ON}) and the off time (t_{OFF}), which can be calculated with Equation (2):

$$\text{angle (in deg)} = \frac{34}{32} \left(\frac{t_{on}}{t_{on} + t_{off}} - \frac{1}{34} \right) 360 \quad (2)$$

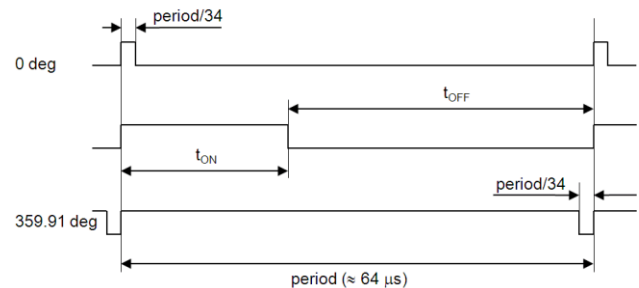

Figure 8: Timing Diagram of the PWM Output

Note that the PWM output can also be used for obtaining a low-frequency analog output. For this purpose, the PWM signal must be low-pass filtered. Take caution, however, since the low-pass filter (with time constant τ) smears the zero-angle transition. The transition width is $\omega \cdot \tau$, where ω is the rotation speed.

An analog signal emulating a usual potentiometer can be constructed from the PWM output by low-pass filtering (see Figure 9). The output is a voltage proportional to the angle, ratiometric between the supply (VDD) and GND. Note that in this example the supply must be larger than 3.3V to supply the MagAlpha correctly.

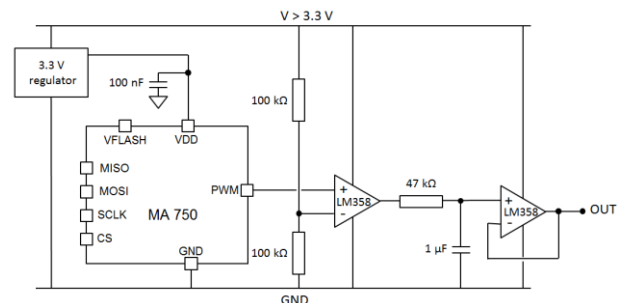

Figure 9: Typical Circuit for Replacement of an Analog Potentiometer

One-Time Programmable (OTP) Programming

The one-time programmable (OTP) memory can permanently store the content of the programmable registers. The OTP memory is made of poly-silicon fuses. By activating the flash command, the content of an entire register can be stored in the OTP memory. The flash command consists of setting bit F_n in register 9 (where n is the register number to be flashed). For flashing the register, when the bit F_n is set, the register n is stored permanently. It is important to note that only one register can be flashed at a time. It is possible to operate the MagAlpha without flashing the registers (see Figure 10).

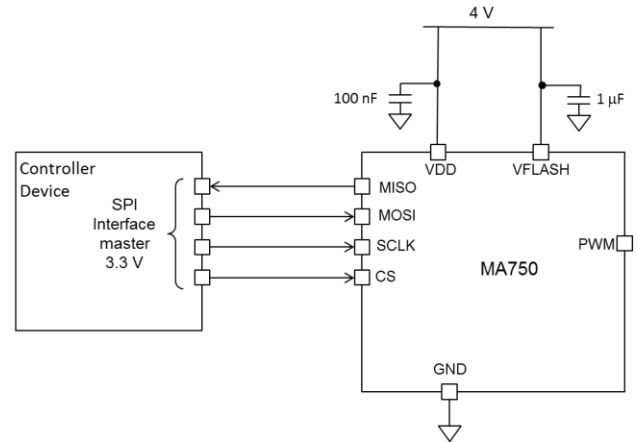

Figure 10: Circuit for Flashing

Burning the fuses during the flash process is irreversible. Once a register is flashed, the default values at power-up are always the same. After flashing, the content of the registers can no longer be modified.

Flashing Procedure

Prior to flashing, it is recommended to test the MagAlpha with the new settings and verify the performance of the sensor. Then, proceed with the flashing using the steps below:

1. Send the parameter to the register.
2. Read back for verification.
3. Connect VFLASH to VDD.
4. Raise VDD to 4V.
5. Set the bit corresponding to the register to be flashed in register 9.
6. Untie VFLASH.
7. Return VDD to 3.3V.
8. Switch the MagAlpha off and on.
9. Check by reading back the register content.

Permanently Storing the Zero Position

The following example shows how to set and flash the zero position at 50 deg. Note that permanently storing the zero position requires burning the register 4.

1. Convert into binary within a resolution of 8 bits. $50/360 * 256 = 35.56$. The closest 8 bit binary value is 00100100 (≈ 50.63 deg).
2. Store the 8 MSB (00100100) of the zero position in register 4:

command	reg. address	MSB	value	LSB
0 0 1 0	0 1 0 0	0 0 1 0	0 0 1 0	0 0 0 0

3. Read back register 4:

command	reg. address	MSB	value	LSB
0 0 0 1	0 1 0 0	0 0 0 0	0 0 0 0	0 0 0 0

If the programming was correct, the MagAlpha replies with the register 4 content:

Angle out	MSB	value	LSB
A(15:12) A(11:8)	0 0 1 0	0 0 1 0	0 0 0 0

Completing Flashing

1. Connect VFLASH to VDD (4V).
 2. Flash register 4:
- | command | reg. address | MSB | value | LSB |
|---------|--------------|---------|---------|---------|
| 0 0 1 0 | 1 0 0 1 | 0 0 0 1 | 0 0 0 0 | 0 0 0 0 |
3. Disconnect VFLASH from VDD.
 4. Turn the MagAlpha off and on (with VDD back to the normal 3.3V value).
 5. Read back registers 4 to verify that the flashing was successfully accomplished.

For flashing multiple registers, send the flash command one by one. The flashing rate is specified in Sensor Output Specifications in the EC table.

Note: Flashing of the OTP registers requires raising both 3.3V VDD and VFlash to 4V. Isolate other devices sharing the 3.3V VDD rail if they are not tolerant to 4V.

PACKAGE INFORMATION

QFN-16 (3mmx3mm)

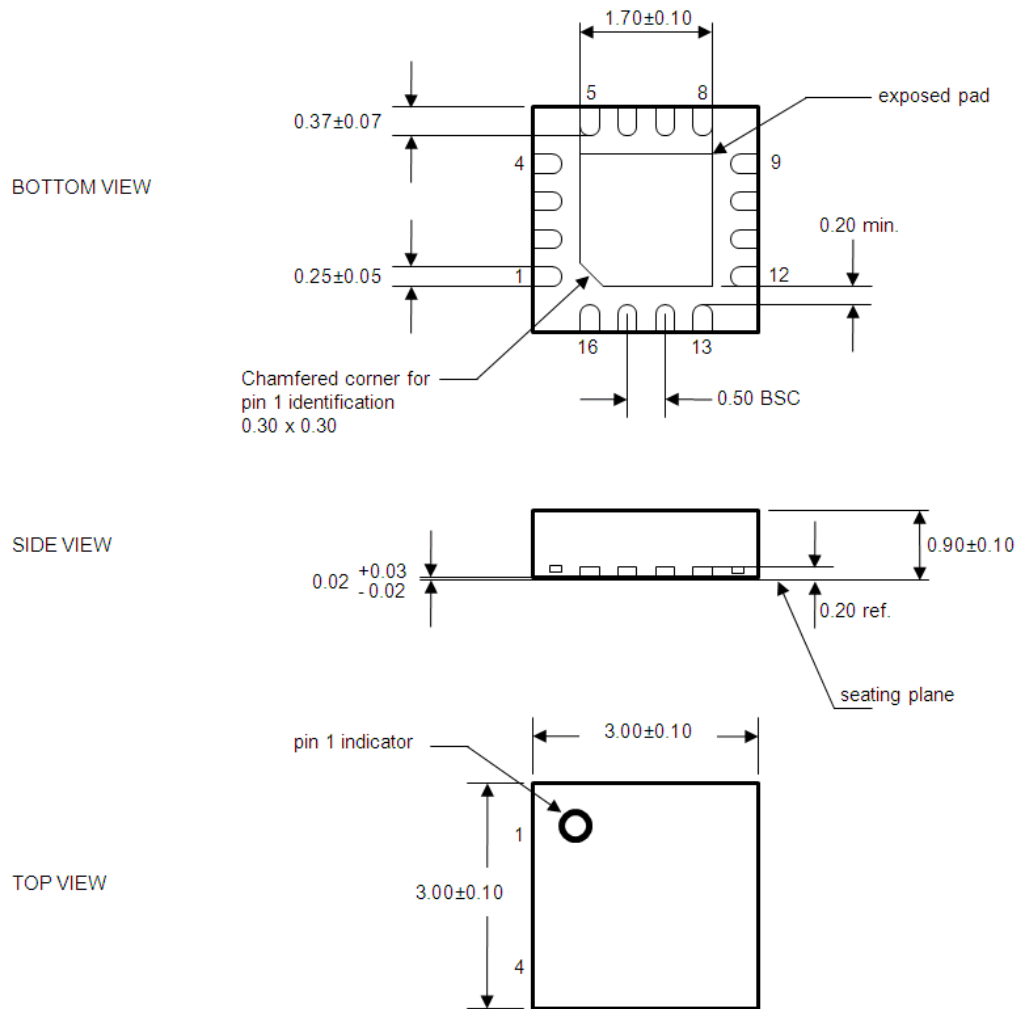

NOTES:

1. All dimensions are in mm.
2. Package dimensions do not include mold flash, protrusions, burrs, or metal smearing.
3. Coplanarity shall be 0.08.
4. Compliant with JEDEC MO-220.

NOTICE: The information in this document is subject to change without notice. Users should warrant and guarantee that third party Intellectual Property rights are not infringed upon when integrating MPS products into any application. MPS will not assume any legal responsibility for any said applications.

APPENDIX A: DEFINITIONS

- Resolution (3σ noise level)** The smallest angle increment distinguishable from the noise. Here, the resolution is defined as 3 times σ (the standard deviation in degrees) taken over 1000 data points at a constant position. The resolution in bits is obtained with: $\log_2(360/6\sigma)$.
- Refresh Rate** Rate at which new data points are stored in the output buffer.
- Latency** The time between the data-ready at the output and the instant at which the shaft passes that position. The lag in degrees is $lag = latency \cdot v$, where v is the angular velocity in deg/s.
- Power-Up Time** Time until the sensor delivers valid data starting at power up.
- Integral Non-Linearity (INL)** Maximum deviation between the noiseless sensor output and the shaft angle if the shaft zero angle coincides with the sensor zero angle.
- Drift** Angle variation rate when one parameter is changed (e.g.: temperature, VDD) and all the others, including the shaft angle, are maintained constant.

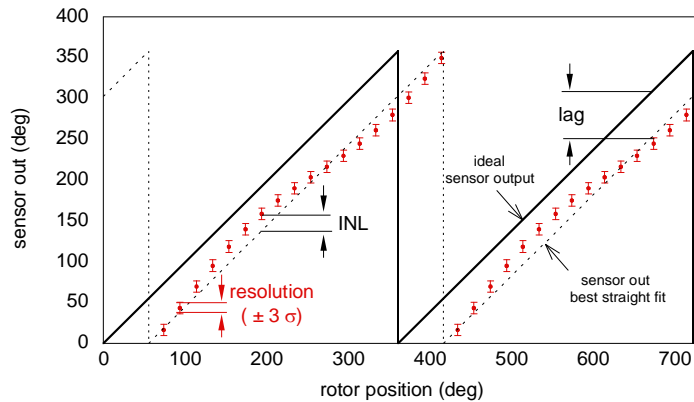

Figure A1: Absolute Angle Errors

- Overall Reproducibility** Maximum variation between two readings, successive or not, of the same shaft position at a fixed magnetic field over the complete temperature range.