

EVALUATION KIT
AVAILABLE

MAXIM

16-Bit, 85ksp/s ADC with 10 μ A Shutdown

MAX195

General Description

The MAX195 is a 16-bit successive-approximation analog-to-digital converter (ADC) that combines high speed, high accuracy, low power consumption, and a 10 μ A shutdown mode. Internal calibration circuitry corrects linearity and offset errors to maintain the full rated performance over the operating temperature range without external adjustments. The capacitive-DAC architecture provides an inherent 85ksp/s track/hold function.

The MAX195, with an external reference (up to +5V), offers a unipolar (0V to V_{REF}) or bipolar (-V_{REF} to V_{REF}) pin-selectable input range. Separate analog and digital supplies minimize digital-noise coupling.

The chip select ($\overline{\text{CS}}$) input controls the three-state serial-data output. The output can be read either during conversion as the bits are determined, or following conversion at up to 5Mbps using the serial clock (SCLK). The end-of-conversion ($\overline{\text{EOC}}$) output can be used to interrupt a processor, or can be connected directly to the convert input ($\overline{\text{CONV}}$) for continuous, full-speed conversions.

The MAX195 is available in 16-pin DIP, wide SO, and ceramic sidebraze packages.

Applications

- Portable Instruments
- Audio
- Industrial Controls
- Robotics
- Multiple Transducer Measurements
- Medical Signal Acquisition
- Vibrations Analysis
- Digital Signal Processing

Pin Configuration

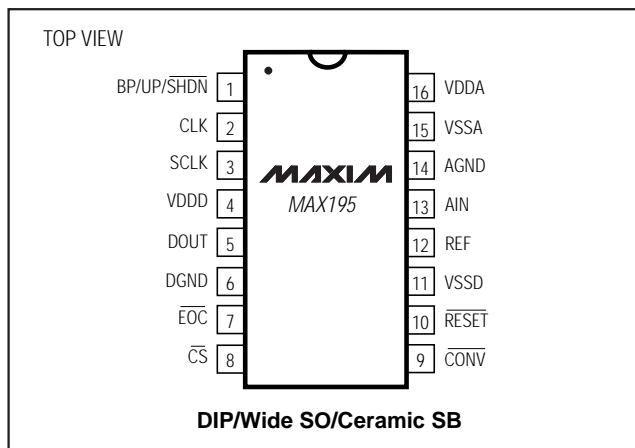

Features

- ◆ 16 Bits, No Missing Codes
- ◆ 90dB SINAD
- ◆ 9.4 μ s Conversion Time
- ◆ 10 μ A (max) Shutdown Mode
- ◆ Built-In Track/Hold
- ◆ AC and DC Specified
- ◆ Unipolar (0V to V_{REF}) and Bipolar (-V_{REF} to V_{REF}) Input Range
- ◆ Three-State Serial-Data Output
- ◆ Small 16-Pin DIP, SO, and Ceramic SB Packages

Ordering Information

PART	TEMP. RANGE	PIN-PACKAGE
MAX195BCPE	0°C to +70°C	16 Plastic DIP
MAX195BCWE	0°C to +70°C	16 Wide SO
MAX195ACDE	0°C to +70°C	16 Ceramic SB
MAX195BC/D	0°C to +70°C	Dice*
MAX195BEPE	-40°C to +85°C	16 Plastic DIP
MAX195BEWE	-40°C to +85°C	16 Wide SO
MAX195AEDE	-40°C to +85°C	16 Ceramic SB
MAX195AMDE	-55°C to +125°C	16 Ceramic SB**
MAX195BMDE	-55°C to +125°C	16 Ceramic SB**

* Dice are specified at T_A = +25°C, DC parameters only.

** Contact factory for availability and processing to MIL-STD-883.

Functional Diagram

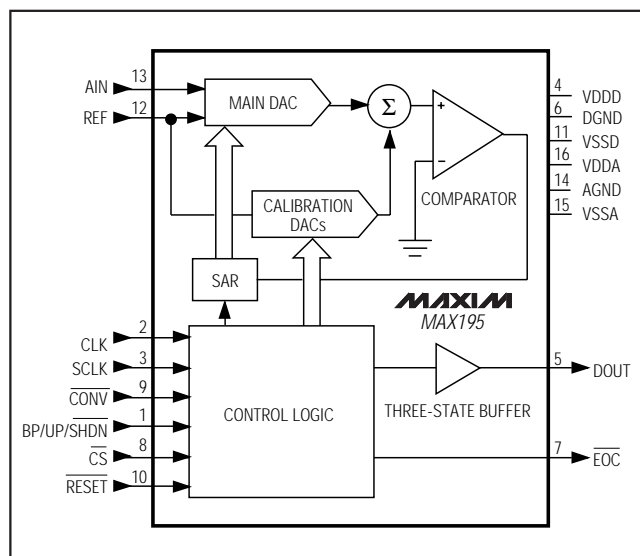

MAXIM

Maxim Integrated Products 1

For free samples & the latest literature: <http://www.maxim-ic.com>, or phone 1-800-998-8800.
For small orders, phone 408-737-7600 ext. 3468.

16-Bit, 85ksps ADC with 10 μ A Shutdown

ABSOLUTE MAXIMUM RATINGS

VDDD to DGND	+7V	Continuous Power Dissipation (T _A = +70°C)	
VDDA to AGND	+7V	Plastic DIP (derate 10.53mW/°C above +70°C)	842mW
VSSD to DGND	+0.3V to -6V	Wide SO (derate 9.52mW/°C above +70°C)	762mW
VSSA to AGND	+0.3V to -6V	Ceramic SB (derate 10.53mW/°C above +70°C)	842mW
VDDD to VDDA, VSSD to VSSA	±0.3V	Operating Temperature Ranges	
AIN, REF	(VSSA - 0.3V) to (VDDA + 0.3V)	MAX195_C_E	0°C to +70°C
AGND to DGND	±0.3V	MAX195_E_E	-40°C to +85°C
Digital Inputs to DGND	-0.3V, (VDDA + 0.3V)	MAX195_MDE	-55°C to +125°C
Digital Outputs to DGND	-0.3V, (VDDA + 0.3V)	Storage Temperature Range	-65°C to +160°C
		Lead Temperature (soldering, 10sec)	+300°C

Stresses beyond those listed under "Absolute Maximum Ratings" may cause permanent damage to the device. These are stress ratings only, and functional operation of the device at these or any other conditions beyond those indicated in the operational sections of the specifications is not implied. Exposure to absolute maximum rating conditions for extended periods may affect device reliability.

ELECTRICAL CHARACTERISTICS

(VDDD = VDDA = +5V, VSSD = VSSA = -5V, f_{CLK} = 1.7MHz, V_{REF} = +5V, T_A = T_{MIN} to T_{MAX}, unless otherwise noted. Typical values are at T_A = +25°C.)

PARAMETER	SYMBOL	CONDITIONS	MIN	TYP	MAX	UNITS
ACCURACY (Note 1)						
Resolution	RES		16			Bits
Differential Nonlinearity	DNL	MAX195A			±1	LSB
		MAX195B			±2	
Integral Nonlinearity	INL	MAX195A			±0.003	%FSR
		MAX195B			±0.004	
Unipolar/Bipolar Offset Error		MAX195A, V _{REF} = 4.75V			±3	LSB
		MAX195B, V _{REF} = 4.75V			±4	
Unipolar/Bipolar Offset Tempco				0.4		ppm/°C
Unipolar Full-Scale Error		V _{REF} = 4.75V			±0.0075	%FSR
Bipolar Full-Scale Error		V _{REF} = 4.75V			±0.018	%FSR
Full-Scale Tempco				0.1		ppm/°C
Power-Supply Rejection Ratio (VDDA and VSSA only)		VDDA = 4.75V to 5.25V, V _{REF} = 4.75V	65			dB
		VSSA = -5.25V to -4.75V, V _{REF} = 4.75V	65			
ANALOG INPUT						
Input Range		Unipolar	0		V _{REF}	V
		Bipolar	-V _{REF}		V _{REF}	
Input Capacitance		Unipolar		250		pF
		Bipolar		125		
DYNAMIC PERFORMANCE (f _s = 85kHz, bipolar range AIN = -5V to +5V, 1kHz) (Note 1)						
Signal-to-Noise plus Distortion Ratio (Note 2)	SINAD	T _A = +25°C	87	90		dB
Total Harmonic Distortion (up to the 5th harmonic) (Note 2)	THD	T _A = +25°C		-97	-90	dB
Peak Spurious Noise (Note 2)		T _A = +25°C			-90	dB
Conversion Time	t _{CONV}	16 (t _{CLK})	9.4			μs
Clock Frequency (Notes 3, 4)	f _{CLK}				1.7	MHz
Serial Clock Frequency	f _{SCLK}				5	MHz

16-Bit, 85ksps ADC with 10 μ A Shutdown

MAX195

ELECTRICAL CHARACTERISTICS (continued)

(VDDD = VDDA = +5V, VSSD = VSSA = -5V, fCLK = 1.7MHz, VREF = +5V, TA = TMIN to TMAX, unless otherwise noted. Typical values are at TA = +25°C.)

PARAMETER	SYMBOL	CONDITIONS	MIN	TYP	MAX	UNITS
DIGITAL INPUTS (CLK, CS, CONV, RESET, SCLK, BP/UP/SHDN)						
CLK, CS, CONV, RESET, SCLK Input High Voltage	VIH	VDDD = 5.25V	2.4			V
CLK, CS, CONV, RESET, SCLK Input Low Voltage	VIL	VDDD = 4.75V			0.8	V
CLK, CS, CONV, RESET, SCLK Input Capacitance (Note 3)					10	pF
CLK, CS, CONV, RESET, SCLK Input Current		Digital inputs = 0 or 5V			± 10	μ A
BP/UP/SHDN Input High Voltage	VIH		VDDD - 0.5			V
BP/UP/SHDN Input Low Voltage	VIL				0.5	V
BP/UP/SHDN Input Current, High	I _{IH}	BP/UP/SHDN = VDDD			4.0	μ A
BP/UP/SHDN Input Current, Low	I _{IL}	BP/UP/SHDN = 0V	-4.0			μ A
BP/UP/SHDN Mid Input Voltage	V _{IM}		1.5	VDDD - 1.5		V
BP/UP/SHDN Voltage, Floating	V _{FLT}	BP/UP/SHDN = open		2.75		V
BP/UP/SHDN Max Allowed Leakage, Mid Input		BP/UP/SHDN = open	-100		+100	nA
DIGITAL OUTPUTS (DOUT, EOC)						
Output Low Voltage	V _{OL}	VDDD = 4.75V, I _{SINK} = 1.6mA			0.4	V
Output High Voltage	V _{OH}	VDDD = 4.75V, I _{SOURCE} = 1mA	VDDD - 0.5			V
DOUT Leakage Current	I _{LKG}	DOUT = 0 or 5V			± 10	μ A
Output Capacitance (Note 2)					10	pF
POWER REQUIREMENTS						
VDDD			4.75		5.25	V
VSSD			-5.25		-4.75	V
VDDA		By supply-rejection test	4.75		5.25	V
VSSA		By supply-rejection test	-5.25		-4.75	V
VDDD Supply Current	I _{DDD}	VDDD = VDDA = 5.25V, VSSD = VSSA = -5.25V		2.5	4	mA
VSSD Supply Current	I _{SSD}	VDDD = VDDA = 5.25V, VSSD = VSSA = -5.25V		0.9	2	mA
VDDA Supply Current	I _{DDA}	VDDD = VDDA = 5.25V, VSSD = VSSA = -5.25V		3.8	5	mA
VSSA Supply Current	I _{SSA}	VDDD = VDDA = 5.25V, VSSD = VSSA = -5.25V		3.8	5	mA

16-Bit, 85ksps ADC with 10 μ A Shutdown

ELECTRICAL CHARACTERISTICS (continued)

(VDDD = VDDA = +5V, VSSD = VSSA = -5V, f_{CLK} = 1.7MHz, V_{REF} = +5V, T_A = T_{MIN} to T_{MAX}, unless otherwise noted. Typical values are at T_A = +25°C.)

PARAMETER	SYMBOL	CONDITIONS	MIN	TYP	MAX	UNITS
POWER REQUIREMENTS (cont.)						
Power Dissipation		VDDD = VDDA = 5.25V, VSSD = VSSA = -5.25V			80	mW
VDDD Shutdown Supply Current (Note 5)	I _{DDD}	VDDD = VDDA = 5.25V, VSSD = VSSA = -5.25V, BP/UP/SHDN = 0V		1.6	5	μ A
VSSD Shutdown Supply Current	I _{SSD}	VDDD = VDDA = 5.25V, VSSD = VSSA = -5.25V, BP/UP/SHDN = 0V		0.1	5	μ A
VDDA Shutdown Supply Current	I _{DDA}	VDDD = VDDA = 5.25V, VSSD = VSSA = -5.25V, BP/UP/SHDN = 0V		0.1	5	μ A
VSSA Shutdown Supply Current	I _{SSA}	VDDD = VDDA = 5.25V, VSSD = VSSA = -5.25V, BP/UP/SHDN = 0V		0.1	5	μ A

Note 1: Accuracy and dynamic performance tests performed after calibration.

Note 2: Guaranteed by design, not tested.

Note 3: Tested with 50% duty cycle. Duty cycles from 25% to 75% at 1.7MHz are acceptable.

Note 4: See *External Clock* section.

Note 5: Measured in shutdown mode with CLK and SCLK low.

TIMING CHARACTERISTICS

(VDDD = VDDA = +5V, VSSD = VSSA = -5V, unless otherwise noted.)

PARAMETER	SYMBOL	CONDITIONS	T _A = +25°C		T _A = 0°C to +70°C		T _A = -40°C to +85°C		T _A = -55°C to +125°C		UNITS
			TYP		MIN	MAX	MIN	MAX	MIN	MAX	
$\overline{\text{CONV}}$ Pulse Width	t _{cw}				20		30		35		ns
$\overline{\text{CONV}}$ to CLK Falling Synchronization (Note 2)	t _{cc1}					10		10		10	ns
$\overline{\text{CONV}}$ to CLK Rising Synchronization (Note 2)	t _{cc2}					40		40		40	ns
Data Access Time	t _{DV}	C _L = 50pF				80		80		90	ns
Bus Relinquish Time	t _{DH}	C _L = 10pF				40		40		40	ns
CLK to $\overline{\text{EOC}}$ High	t _{CEH}	C _L = 50pF				300		300		350	ns
CLK to $\overline{\text{EOC}}$ Low	t _{CEL}	C _L = 50pF				300		300		350	ns
CLK to DOUT Valid	t _{CD}	C _L = 50pF			100	350	100	375	100	400	ns
SCLK to DOUT Valid	t _{SD}	C _L = 50pF			20	140	20	160	20	160	ns
$\overline{\text{CS}}$ to SCLK Setup Time	t _{CSS}				75		75		75		ns
$\overline{\text{CS}}$ to SCLK Hold Time	t _{CSH}				-10		-10		-10		ns
Acquisition Time	t _{AQ}				2.4		2.4		2.4		μ s
Calibration Time	t _{CAL}	14,000 x t _{CLK}			8.2		8.2		8.2		ms
$\overline{\text{RESET}}$ to CLK Setup Time	t _{RCS}				-40		-40		-40		ns
$\overline{\text{RESET}}$ to CLK Hold Time	t _{RCH}				120		120		120		ns
Start-Up Time (Note 6)	t _{SU}	Exiting shutdown	50								μ s

Note 6: Settling time required after deasserting shutdown to achieve less than 0.1LSB additional error.

16-Bit, 85ksps ADC with 10 μ A Shutdown

Pin Description

MAX195

PIN	NAME	FUNCTION
1	BP/UP/ $\overline{\text{SHDN}}$	Bipolar/Unipolar/Shutdown Input. Three-state input selects bipolar or unipolar input range, or shutdown. 0V = shutdown, +5V = unipolar, floating = bipolar.
2	CLK	Conversion Clock Input
3	SCLK	Serial Clock Input is used to shift data out between conversions. May be asynchronous to CLK.
4	VDDD	+5V Digital Power Supply
5	DOUT	Serial Data Output, MSB first
6	DGND	Digital Ground
7	$\overline{\text{EOC}}$	End-of-Conversion/Calibration Output—normally low. Rises one clock cycle after the beginning of conversion or calibration and falls one clock cycle after the end of either. May be used as an output framing signal.
8	$\overline{\text{CS}}$	Chip-Select Input—active low. Enables the serial interface and the three-state data output (DOUT).
9	$\overline{\text{CONV}}$	Convert-Start Input—active low. Conversion begins on the falling edge after $\overline{\text{CONV}}$ goes low if the input signal has been acquired; otherwise, on the falling clock edge after acquisition.
10	$\overline{\text{RESET}}$	Reset Input. Pulling $\overline{\text{RESET}}$ low places the ADC in an inactive state. Rising edge resets control logic and begins calibration.
11	VSSD	-5V Digital Power Supply
12	REF	Reference Input, 0 to 5V
13	AIN	Analog Input, 0 to V_{REF} unipolar or $\pm V_{\text{REF}}$ bipolar range
14	AGND	Analog Ground
15	VSSA	-5V Analog Power Supply
16	VDDA	+5V Analog Power Supply

Detailed Description

The MAX195 uses a successive-approximation register (SAR) to convert an analog input to a 16-bit digital code, which outputs as a serial data stream. The data bits can be read either during the conversion, at the CLK clock rate, or between conversions asynchronous with CLK at the SCLK rate (up to 5Mbps).

The MAX195 includes a capacitive digital-to-analog converter (DAC) that provides an inherent track/hold input. The interface and control logic are designed for easy connection to most microprocessors (μ Ps), limiting the need for external components. In addition to the SAR and DAC, the MAX195 includes a serial interface, a sampling comparator used by the SAR, ten calibration DACs, and control logic for calibration and conversion.

The DAC consists of an array of 16 capacitors with binary weighted values plus one “dummy LSB” capacitor (Figure 1). During input acquisition in unipolar mode, the array's common terminal is connected to AGND and all free terminals are connected to the input signal (AIN). After acquisition, the common terminal is disconnected from AGND and the free terminals are

disconnected from AIN, trapping a charge proportional to the input voltage on the capacitor array.

The free terminal of the MSB (largest) capacitor is connected to the reference (REF), which pulls the common terminal (connected to the comparator) positive. Simultaneously, the free terminals of all other capacitors in the array are connected to AGND, which drives the comparator input negative. If the analog input is near V_{REF} , connecting the MSB's free terminal to REF only pulls the comparator input slightly positive. However, connecting the remaining capacitor's free terminals to ground drives the comparator input well below ground, so the comparator input is negative, the comparator output is low, and the MSB is set high. If the analog input is near ground, the comparator output is high and the MSB is low.

Following this, the next largest capacitor is disconnected from AGND and connected to REF, and the comparator determines the next bit. This continues until all bits have been determined. For a bipolar input range, the MSB capacitor is connected to REF rather than AIN during input acquisition, which results in an input range of V_{REF} to $-V_{\text{REF}}$.

16-Bit, 85ksps ADC with 10 μ A Shutdown

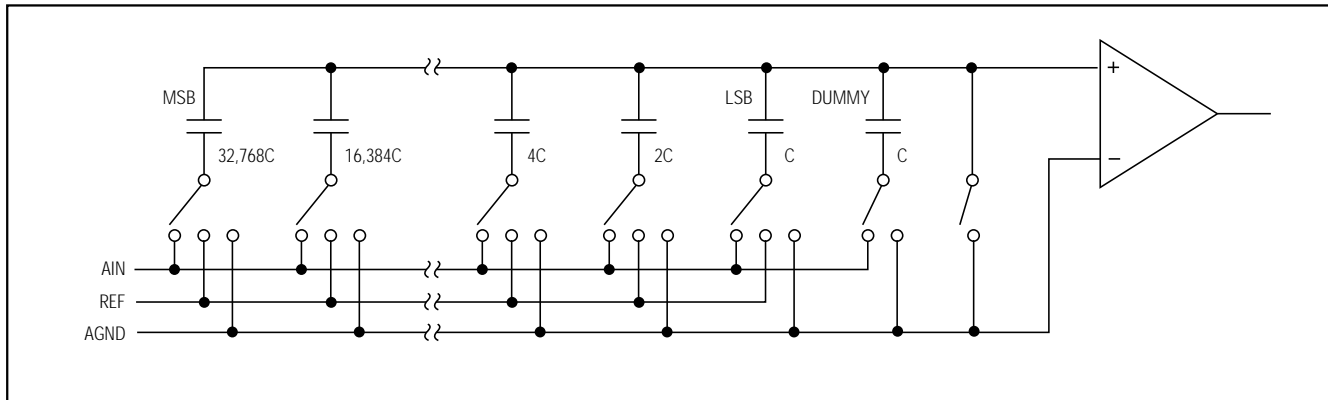

Figure 1. Capacitor DAC Functional Diagram

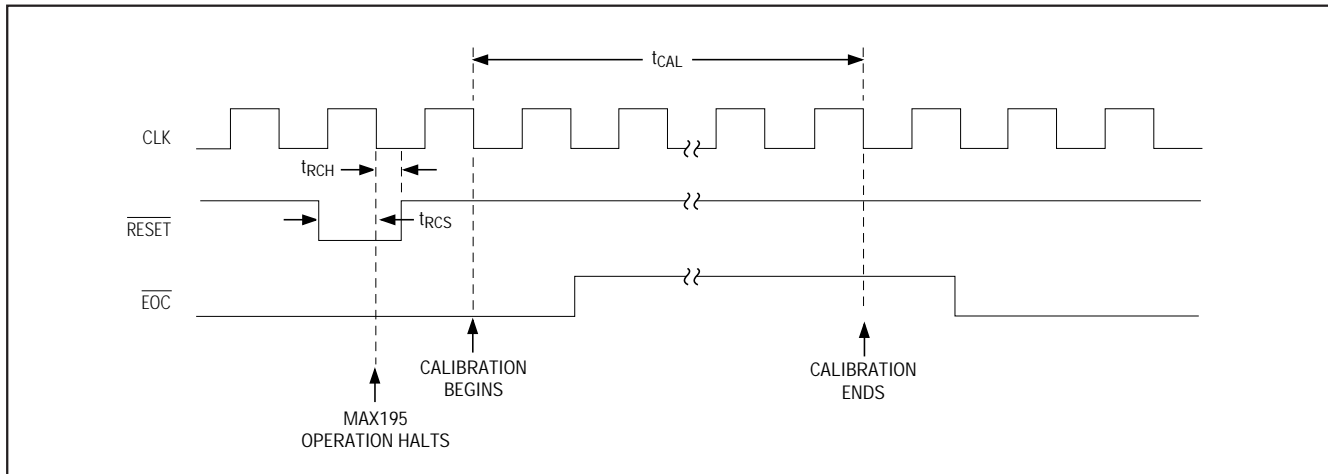

Figure 2. Initiating Calibration

Calibration

In an ideal DAC, each of the capacitors associated with the data bits would be exactly twice the value of the next smaller capacitor. In practice, this results in a range of values too wide to be realized in an economically feasible size. The capacitor array actually consists of two arrays, which are capacitively coupled to reduce the LSB array's effective value. The capacitors in the MSB array are production trimmed to reduce errors. Small variations in the LSB capacitors contribute insignificant errors to the 16-bit result.

Unfortunately, trimming alone does not yield 16-bit performance or compensate for changes in performance due to changes in temperature, supply voltage, and other parameters. For this reason, the MAX195 includes a calibration DAC for each capacitor in the MSB array. These DACs are capacitively coupled to the main DAC

output and offset the main DAC's output according to the value on their digital inputs. During calibration, the correct digital code to compensate for the error in each MSB capacitor is determined and stored. Thereafter, the stored code is input to the appropriate calibration DAC whenever the corresponding bit in the main DAC is high, compensating for errors in the associated capacitor.

The MAX195 calibrates automatically on power-up. To reduce the effects of noise, each calibration experiment is performed many times and the results are averaged. Calibration requires about 14,000 clock cycles, or 8.2ms at the highest clock (CLK) speed (1.7MHz). In addition to the power-up calibration, bringing $\overline{\text{RESET}}$ low halts MAX195 operation, and bringing it high again initiates a calibration (Figure 2).

16-Bit, 85ksp/s ADC with 10 μ A Shutdown

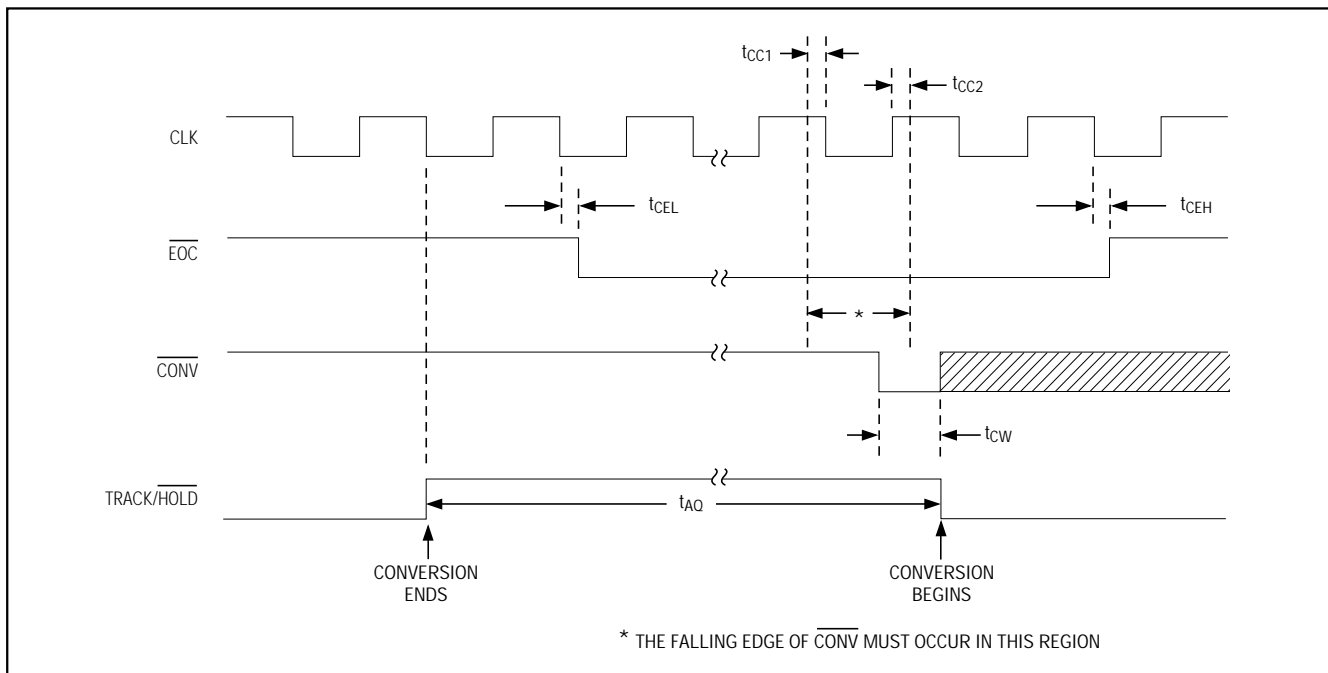

Figure 3. Initiating Conversions—At least 3 CLK cycles since end of previous conversion.

If the power supplies do not settle within the MAX195's power-on delay (500ns minimum), power-up calibration may begin with supply voltages that differ from the final values and the converter may not be properly calibrated. If so, recalibrate the converter (pulse $\overline{\text{RESET}}$ low) before use. For best DC accuracy, calibrate the MAX195 any time there is a significant change in supply voltages, temperature, reference voltage, or clock characteristics (see *External Clock* section) because these parameters affect the DC offset. If linearity is the only concern, much larger changes in these parameters can be tolerated.

Because the calibration data is stored digitally, there is no need either to perform frequent conversions to maintain accuracy or to recalibrate if the MAX195 has been held in shutdown for long periods. However, recalibration is recommended if it is likely that ambient temperature or supply voltages have significantly changed since the previous calibration.

Digital Interface

The digital interface pins consist of $\overline{\text{BP/UP/SHDN}}$, CLK, SCLK, EOC, $\overline{\text{CS}}$, $\overline{\text{CONV}}$, and $\overline{\text{RESET}}$.

$\overline{\text{BP/UP/SHDN}}$ is a three-level input. Leave it floating to configure the MAX195's analog input in bipolar mode ($A_{IN} = -V_{REF}$ to V_{REF}) or connect it high for a unipolar

input ($A_{IN} = 0V$ to V_{REF}). Bringing $\overline{\text{BP/UP/SHDN}}$ low places the MAX195 in its 10 μ A shutdown mode.

A logic low on $\overline{\text{RESET}}$ halts MAX195 operation. The rising edge of $\overline{\text{RESET}}$ initiates calibration as described in the *Calibration* section above.

Begin a conversion by bringing $\overline{\text{CONV}}$ low. After conversion begins, additional convert start pulses are ignored. The convert signal must be synchronized with CLK. The falling edge of $\overline{\text{CONV}}$ must occur during the period shown in Figures 3 and 4. When CLK is not directly controlled by your processor, two methods of ensuring synchronization are to drive $\overline{\text{CONV}}$ from $\overline{\text{EOC}}$ (continuous conversions) or to gate the conversion-start signal with the conversion clock so that $\overline{\text{CONV}}$ can go low only while CLK is low (Figure 5). Ensure that the maximum propagation delay through the gate is less than 40ns.

The MAX195 automatically ensures four CLK periods for track/hold acquisition. If, when $\overline{\text{CONV}}$ is asserted, at least three clock (CLK) cycles have passed since the end of the previous conversion, a conversion will begin on CLK's next falling edge and $\overline{\text{EOC}}$ will go high on the following falling CLK edge (Figure 3). If, when convert is asserted, less than three clock cycles have passed, a conversion will begin on the fourth falling clock edge

16-Bit, 85ksps ADC with 10 μ A Shutdown

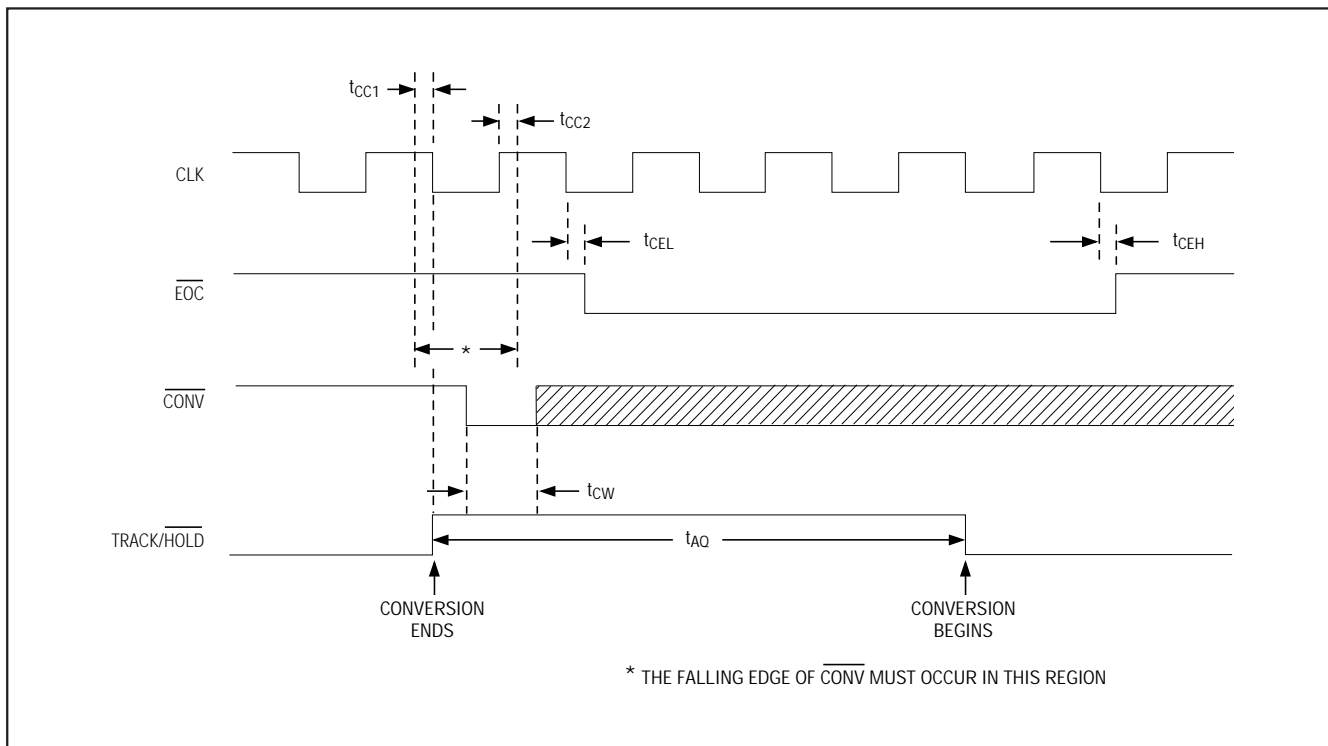

Figure 4. Initiating Conversions—Less than 3 CLK cycles since end of previous conversion.

after the end of the previous conversion and $\overline{\text{EOC}}$ will go high on the following CLK falling edge (Figure 4).

External Clock

The conversion clock (CLK) should have a duty cycle between 25% and 75% at 1.7MHz (the maximum clock frequency). For lower frequency clocks, ensure the minimum high and low times exceed 150ns. The minimum clock rate for accurate conversion is 125Hz for temperatures up to +70°C or 1kHz at +125°C due to leakage of the sampling capacitor array. In addition, CLK should not remain high longer than 50ms at temperatures up to +70°C or 500 μ s at +125°C. If CLK is held high longer than this, $\overline{\text{RESET}}$ must be pulsed low to initiate a recalibration because it is possible that state information stored in internal dynamic memory may be lost. The MAX195's clock can be stopped indefinitely if it is held low.

If the frequency, duty cycle, or other aspects of the clock signal's shape change, the offset created by coupling between CLK and the analog inputs (AIN and REF) changes. Recalibration corrects for this offset and restores DC accuracy.

SPI/QSPI are trademarks of Motorola Corp.

Output Data

The conversion result, clocked out MSB first, is available on DOUT only when $\overline{\text{CS}}$ is held low. Otherwise, DOUT is in a high-impedance state. There are two ways to read the data on DOUT. To read the data bits as they are determined (at the CLK clock rate), hold $\overline{\text{CS}}$ low during the conversion. To read results between conversions, hold $\overline{\text{CS}}$ low and clock SCLK at up to 5MHz.

If you read the serial data bits as they are determined, EOC frames the data bits (Figure 6). Conversion begins with the first falling CLK edge, after $\overline{\text{CONV}}$ goes low and the input signal has been acquired. Data bits are shifted out of DOUT on subsequent falling CLK edges. Clock data in on CLK's rising edge or, if the clock speed is greater than 1MHz, on the following falling edge of CLK to meet the maximum CLK-to-DOUT timing specification. See the *Operating Modes and SPI™/QSPI™ Interfaces* section for additional information. Reading the serial data during the conversion results in the maximum conversion throughput, because a new conversion can begin immediately after the input acquisition period following the previous conversion.

16-Bit, 85ksp/s ADC with 10 μ A Shutdown

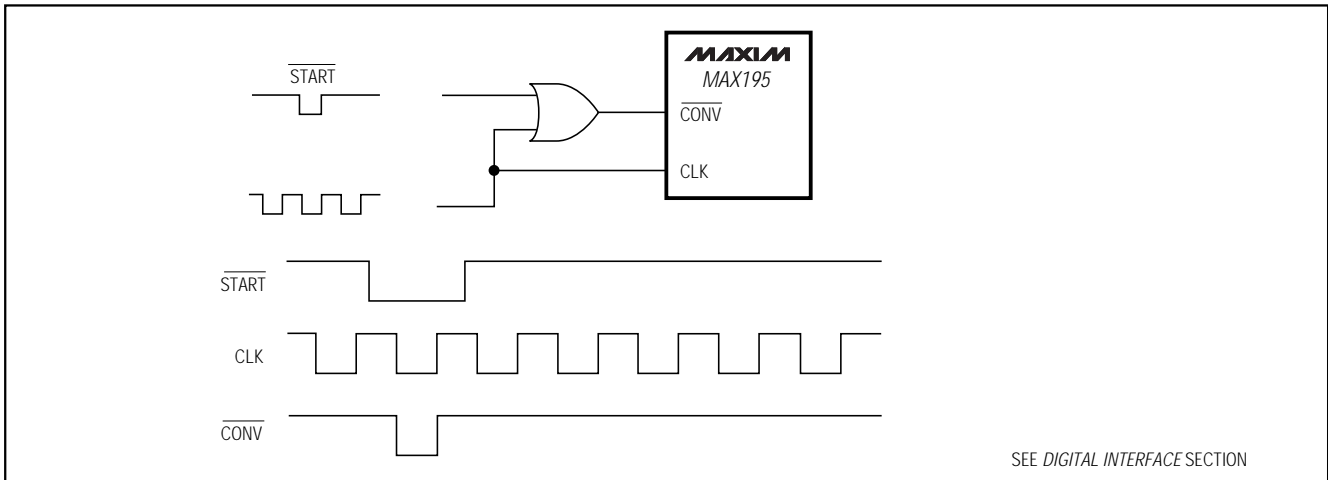

Figure 5. Gating \overline{CONV} to Synchronize with CLK

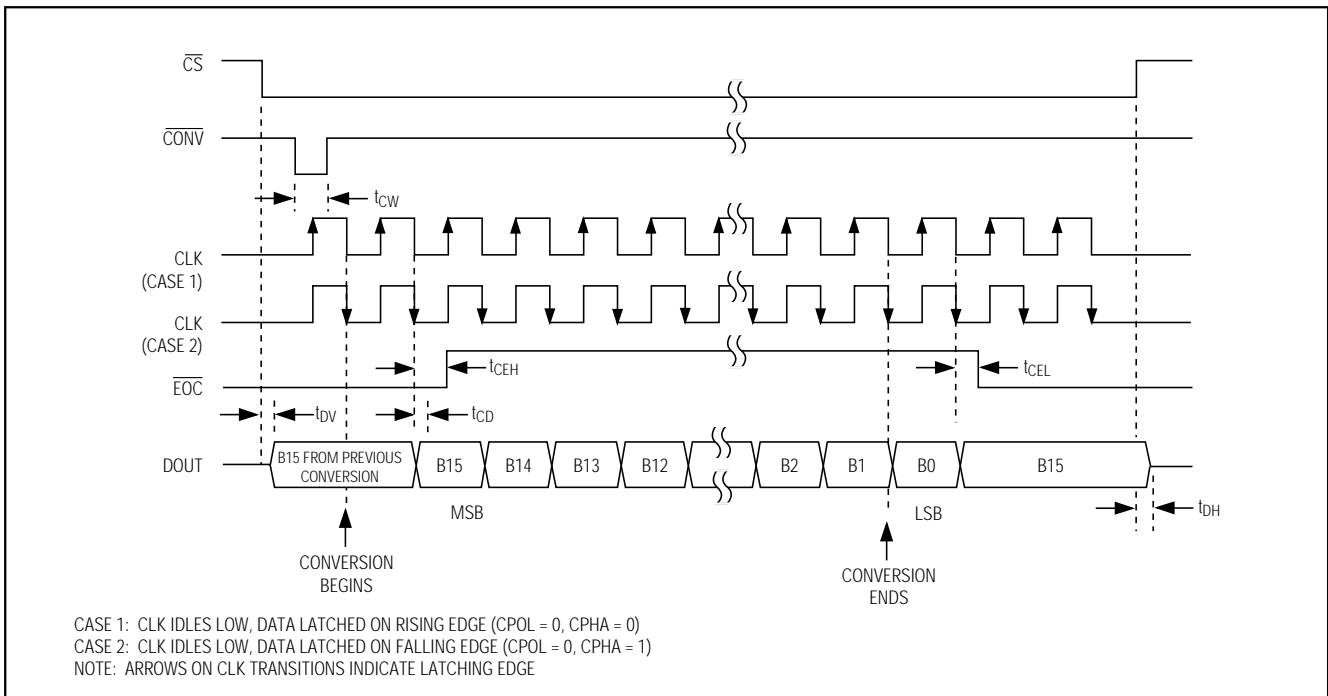

Figure 6. Output Data Format, Reading Data During Conversion (Mode 1)

If you read the data bits between conversions, you can:

- 1) count CLK cycles until the end of the conversion, or
- 2) poll \overline{EOC} to determine when the conversion is finished, or
- 3) generate an interrupt on \overline{EOC} 's falling edge.

Note that the MSB conversion result appears at DOUT after \overline{CS} goes low, but **before** the first SCLK pulse. Each subsequent SCLK pulse shifts out the next conversion bit. The 15th SCLK pulse shifts out the LSB. Additional clock pulses shift out zeros.

16-Bit, 85ksps ADC with 10µA Shutdown

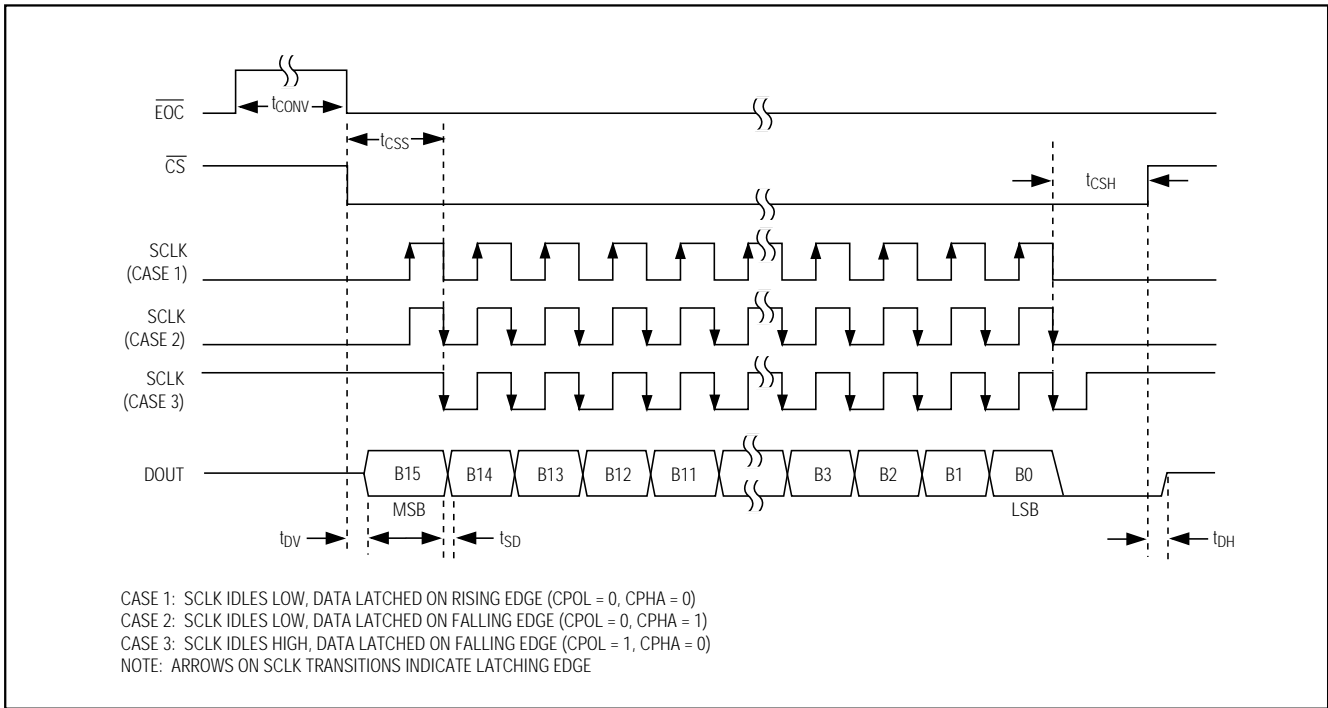

Figure 7. Output Data Format, Reading Data Between Conversions (Mode 2)

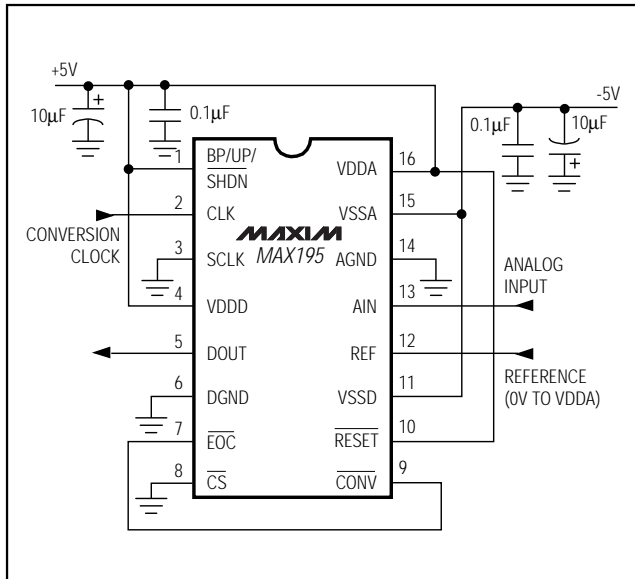

Figure 8. MAX195 in the Simplest Operating Configuration

Data is clocked out on SCLK's falling edge. Clock data in on SCLK's rising edge or, for clock speeds above 2.5MHz, on the following falling edge to meet the maximum SCLK-to-DOUT timing specification (Figure 7). The maximum SCLK speed is 5MHz. See the *Operating Modes and SPI/QSPI Interfaces* section for additional information. When the conversion clock is near its maximum (1.7MHz), reading the data after each conversion (during the acquisition time) results in lower throughput (about 70ksps max) than reading the data during conversions, because it takes longer than the minimum input acquisition time (four cycles at 1.7MHz) to clock 16 data bits at 5Mbps. After the data has been clocked in, leave some time (about 1µs) for any coupled noise on AIN to settle before beginning the next conversion.

Whichever method is chosen for reading the data, conversions can be individually initiated by bringing CONV low, or they can occur continuously by connecting EOC to CONV. Figure 8 shows the MAX195 in its simplest operational configuration.

16-Bit, 85ksps ADC with 10 μ A Shutdown

Table 1. Low-ESR Capacitor Suppliers

COMPANY	CAPACITOR	FACTORY FAX [COUNTRY CODE]	USA TELEPHONE
Sprague	595D series, 592D series	1-603-224-1430	603-224-1961
AVX	TPS series	1-207-283-1941	800-282-4975
Sanyo	OS-CON series, MVGX series	81-7-2070-1174	619-661-6835
Nichicon	PL series	1-708-843-2798	708-843-7500

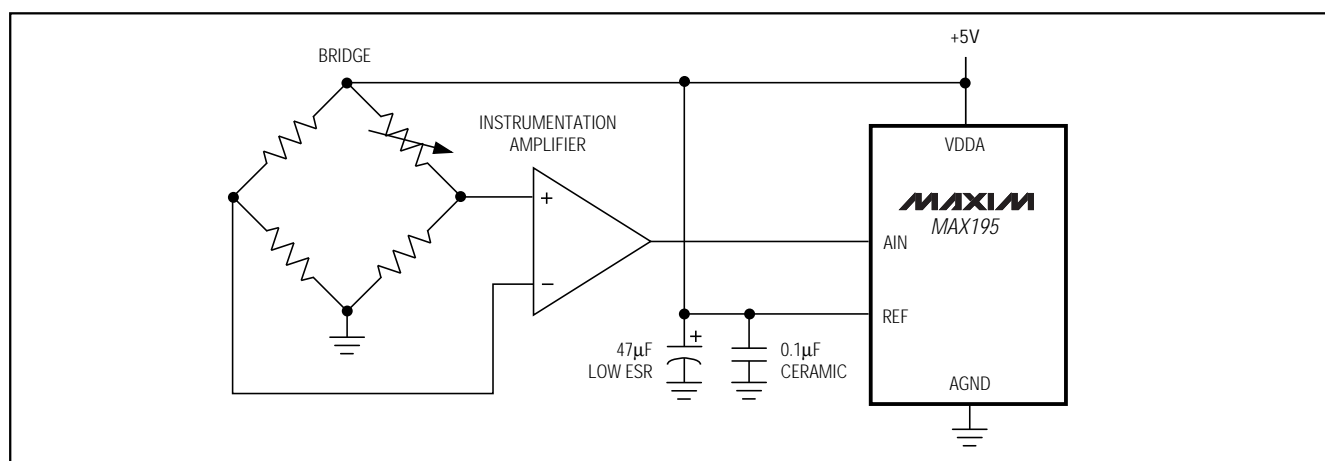

Figure 9. Ratiometric Measurement Without an Accurate Reference

Applications Information

Reference

The MAX195 reference voltage range is 0V to VDDA. When choosing the reference voltage, the MAX195's equivalent input noise (40 μ V_{RMS} in unipolar mode, 80 μ V_{RMS} in bipolar mode) should be considered. Also, if V_{REF} exceeds VDDA, errors will occur due to the internal protection diodes that will begin to conduct, so use caution when using a reference near VDDA (unless V_{REF} and VDDA are virtually identical). V_{REF} must never exceed its absolute maximum rating (VDDA + 0.3V).

The MAX195 needs a good reference to achieve its rated performance. The most important requirement is that the reference must present a low impedance to the REF input. This is often achieved by buffering the reference through an op amp and bypassing the REF input with a large (1 μ F to 47 μ F), low-ESR capacitor in parallel with a 0.1 μ F ceramic capacitor. Low-ESR capacitors are available from the manufacturers listed in Table 1.

The reference must drive the main conversion DAC capacitors as well as the capacitors in the calibration

DACs, all of which may be switching between GND and REF at the conversion clock frequency. The total capacitive load presented can exceed 1000pF and, unlike the analog input (AIN), REF is sampled continuously throughout the conversion.

The first step in choosing a reference circuit is to decide what kind of performance is required. This often suggests compromises made in the interests of cost and size. It is possible that a system may not require an accurate reference at all. If a system makes a ratiometric measurement such as Figure 9's bridge circuit, any relatively noise-free voltage that presents a low impedance at the REF input will serve as a reference. The +5V analog supply suffices if you use a large, low-impedance bypass capacitor to keep REF stable during switching of the capacitor arrays. Do not place a resistance between the +5V supply and the bypass capacitor, because it will cause linearity errors due to the dynamic REF input current, which typically ranges from 300 μ A to 400 μ A.

Figure 10 shows a more typical scheme that provides good AC accuracy. The MAX874's initial accuracy can

16-Bit, 85ksps ADC with 10 μ A Shutdown

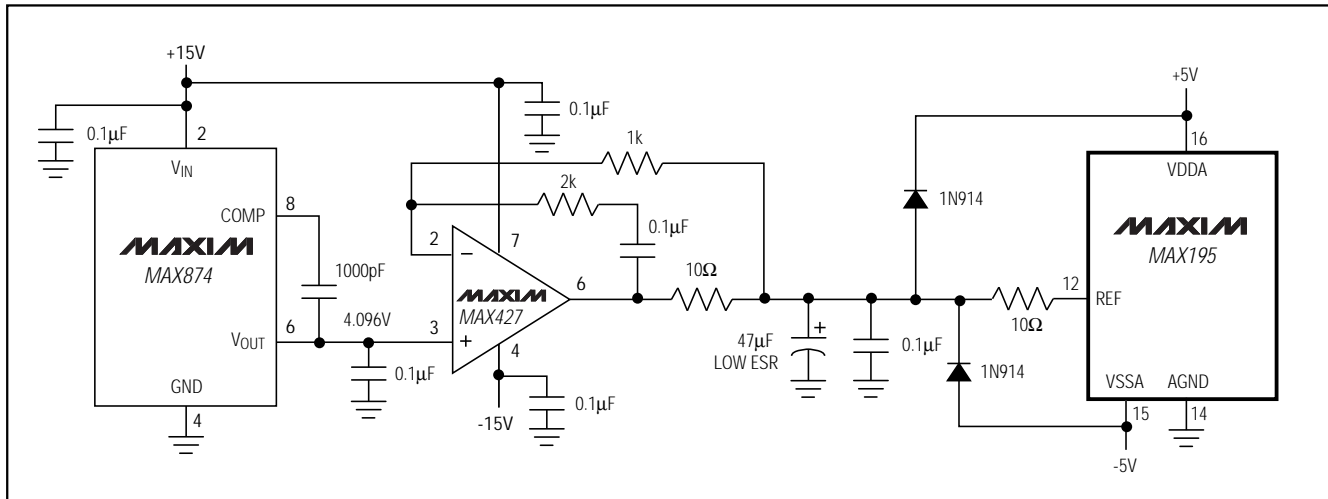

Figure 10. Typical Reference Circuit for AC Accuracy

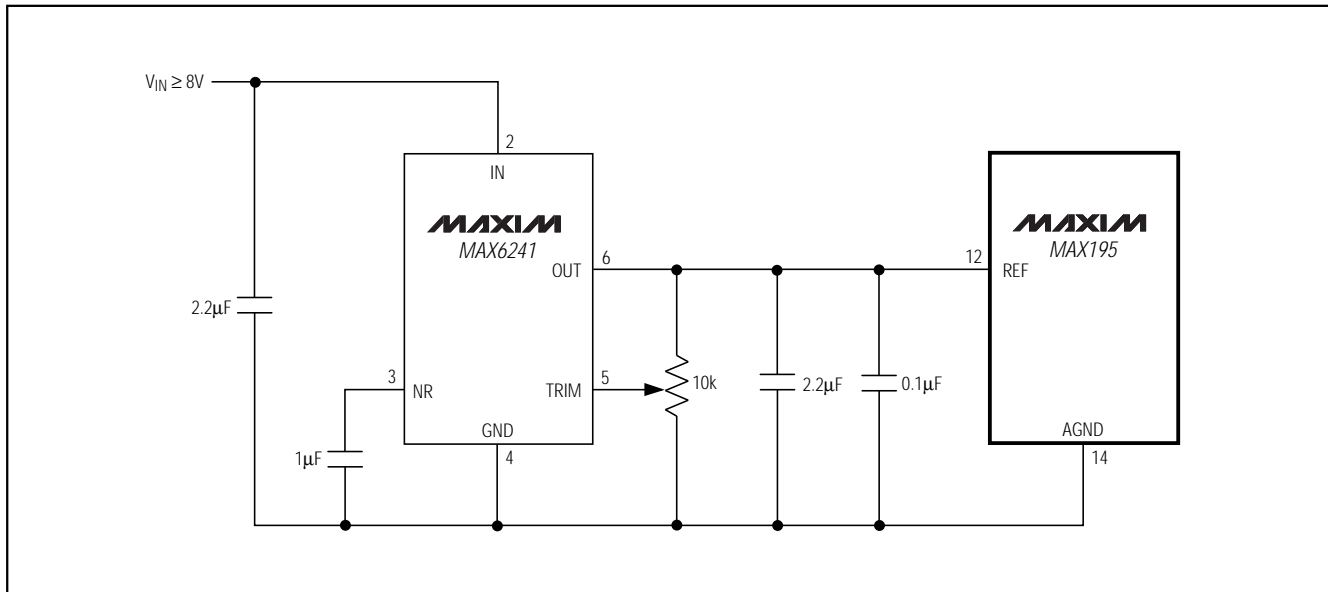

Figure 11. High-Accuracy Reference

be improved by trimming, but the drift is too great to provide good stability over temperature. The MAX427 buffer provides the necessary drive current to stabilize the REF input quickly after capacitance changes.

The reference inaccuracies contribute additional full-scale error. A reference with less than $1/2^{16}$ total error (15 parts per million) over the operating temperature range is required to limit the additional error to less than 1LSB. The MAX6241 achieves a drift specification

of 1ppm/°C (typ). This allows reasonable temperature changes with less than 1LSB error. While the MAX6241's initial-accuracy specification (0.02%) results in an offset error of about ± 14 LSB, the reference voltage can be trimmed or the offset can be corrected in software if absolute DC accuracy is essential. Figure 11's circuit provides outstanding temperature stability and also provides excellent DC accuracy if the initial error is corrected.

16-Bit, 85ksps ADC with 10 μ A Shutdown

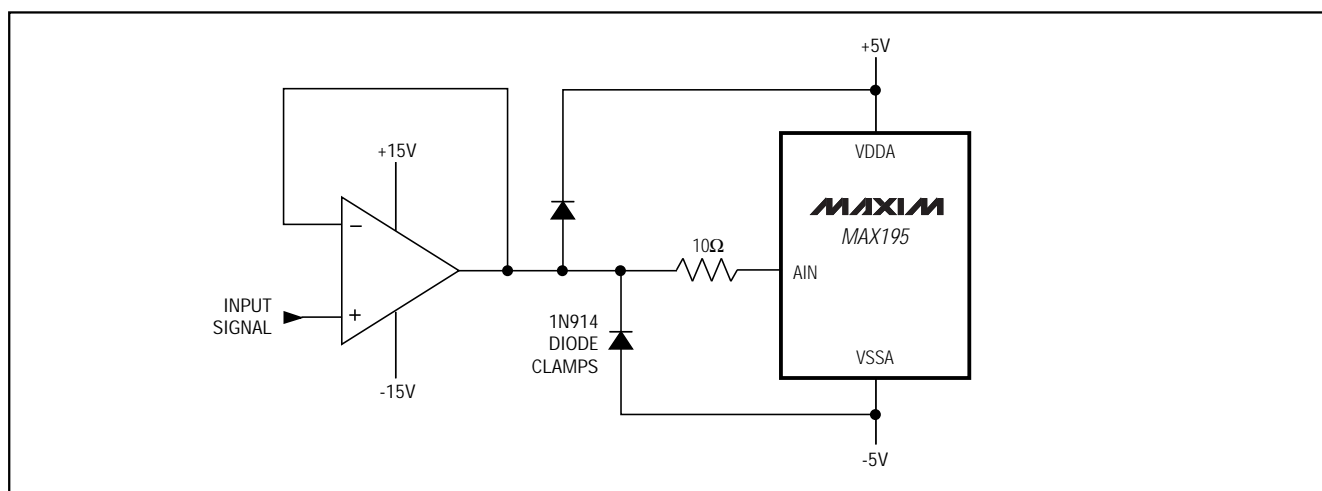

Figure 12. Analog Input Protection for Overvoltage or Improper Supply Sequence

REF and AIN Input Protection

The REF and AIN signals should not exceed the MAX195 supply rails. If this can occur, diode clamp the signal to the supply rails. Use silicon diodes and a 10 Ω current-limiting resistor (Figures 10 and 12) or Schottky diodes without the resistor.

When using the current-limiting resistor, place the resistor between the appropriate input (AIN or REF) and any bypass capacitor. While this results in AC transients at the input due to dynamic input currents, the transients settle quickly and do not affect conversion results. Improperly placing the bypass capacitor directly at the input forms an RC lowpass filter with the current-limiting resistor, which averages the dynamic input current and causes linearity errors.

Analog Input

The MAX195 uses a capacitive DAC that provides an inherent track/hold function. The input impedance is typically 30 Ω in series with 250pF in unipolar mode and 50 Ω in series with 125pF in bipolar mode.

Input Range

The analog input range can be either unipolar (0V to V_{REF}) or bipolar ($-V_{REF}$ to V_{REF}), depending on the state of the BP/UP/SHDN pin (see *Digital Interface* section). The reference range is 0V to V_{DDA} . When choosing the reference voltage, the equivalent MAX195 input noise (40 μ V_{RMS} in unipolar mode, 80 μ V_{RMS} in bipolar mode) should be considered.

Input Acquisition and Settling

Four conversion-clock periods are allocated for acquiring the input signal. At the highest conversion rate, four clock periods is 2.4 μ s. If more than three clock cycles have occurred since the end of the previous conversion, conversion begins on the next falling clock edge after \overline{CONV} goes low. Otherwise, bringing \overline{CONV} low begins a conversion on the fourth falling clock edge after the previous conversion. This scheme ensures the minimum input acquisition time is four clock periods.

Most applications require an input buffer amplifier. If the input signal is multiplexed, the input channel should be switched near the beginning of a conversion, rather than near the end of or after a conversion (Figure 13). This allows time for the input buffer amplifier to respond to a large step change in input signal. The input amplifier must have a high enough slew rate to complete the required output voltage change *before* the beginning of the acquisition time.

At the beginning of acquisition, the capacitive DAC is connected to the amplifier output, causing some output disturbance. Ensure that the sampled voltage has settled to within the required limits before the end of the acquisition time. If the frequency of interest is low, AIN can be bypassed with a large enough capacitor to charge the capacitive DAC with very little change in voltage (Figure 14). However, for AC use, AIN must be driven by a wideband buffer (at least 10MHz), which must be stable with the DAC's capacitive load (in parallel with any AIN bypass capacitor used) and also must settle quickly (Figure 15 or 16).

16-Bit, 85ksps ADC with 10 μ A Shutdown

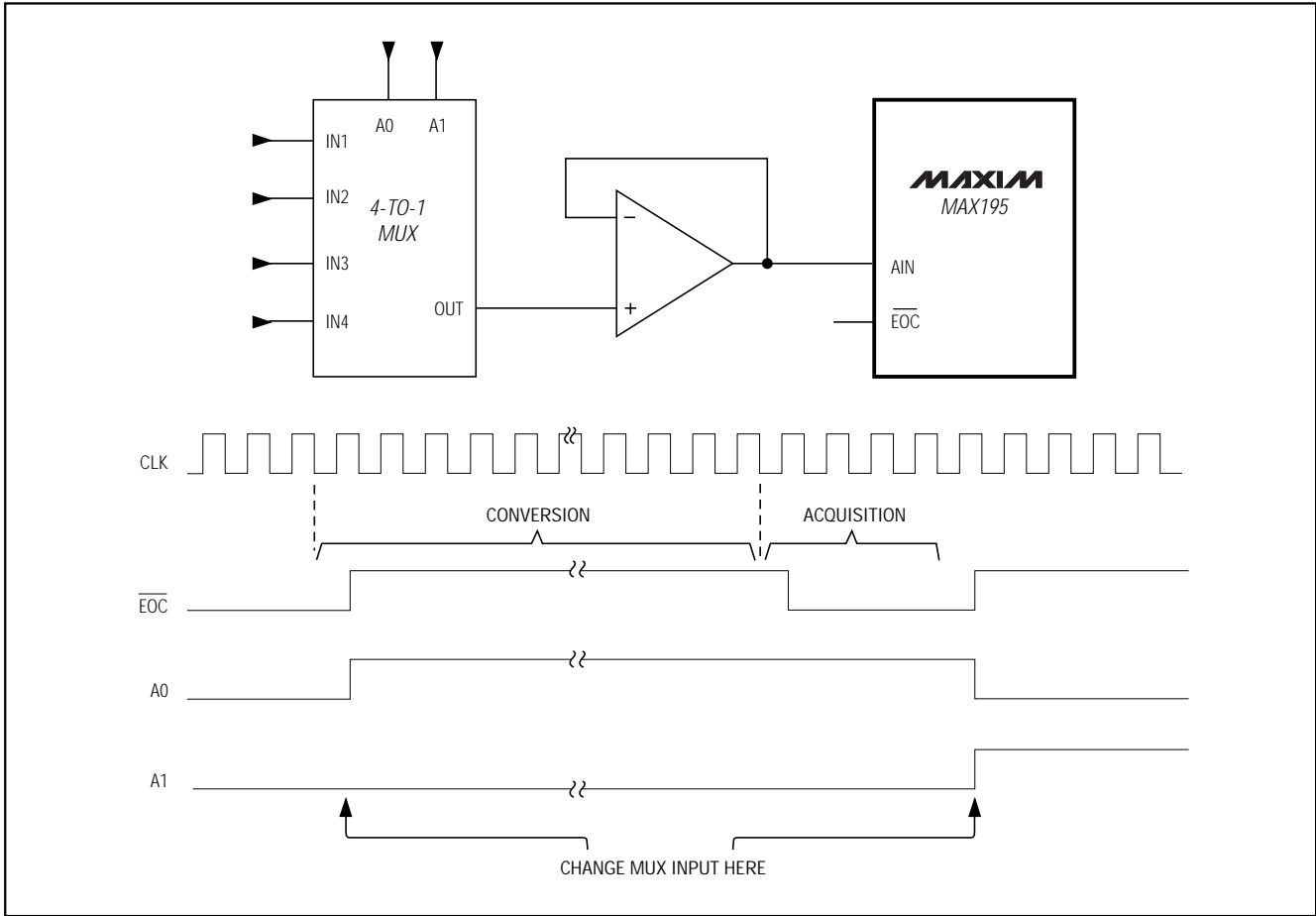

Figure 13. Change multiplexer input near beginning of conversion to allow time for slewing and settling.

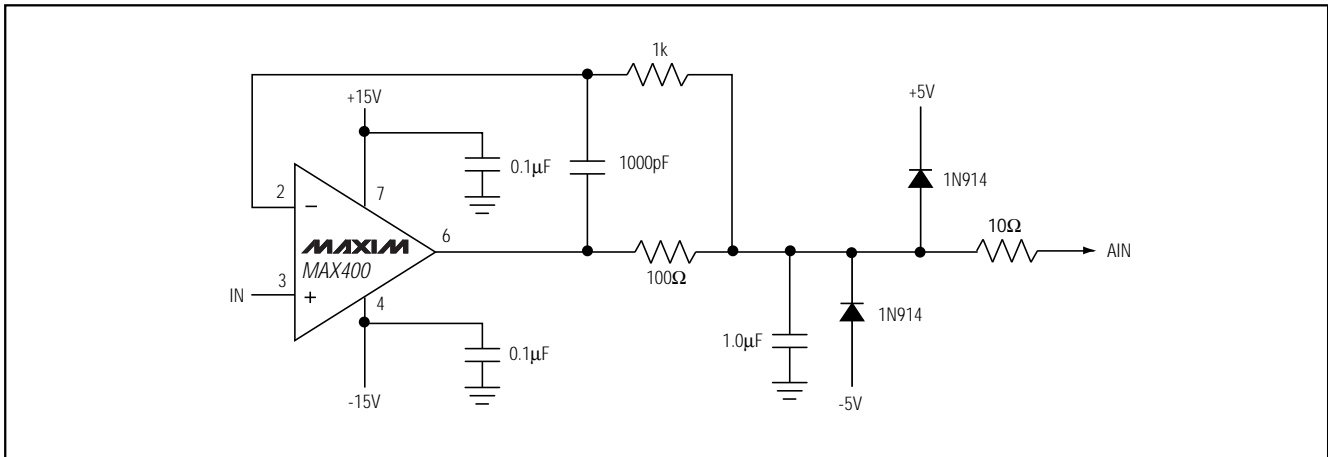

Figure 14. MAX400 Drives AIN for Low-Frequency Use

16-Bit, 85ksps ADC with 10 μ A Shutdown

Digital Noise

Digital noise can easily be coupled to AIN and REF. The conversion clock (CLK) and other digital signals that are active during input acquisition contribute noise to the conversion result. If the noise signal is synchronous to the sampling interval, an effective input offset is produced. Asynchronous signals produce random noise on the input, whose high-frequency components may be aliased into the frequency band of interest. Minimize noise by presenting a low impedance (at the frequencies contained in the noise signal) at the inputs. This requires bypassing AIN to AGND, or buffering the input with an amplifier that has a small-signal bandwidth of several megahertz, or preferably both. AIN has a bandwidth of about 16MHz.

Offsets resulting from synchronous noise (such as the conversion clock) are canceled by the MAX195's calibration scheme. However, because the magnitude of the offset produced by a synchronous signal depends on the signal's shape, recalibration may be appropriate if the shape or relative timing of the clock or other digital signals change, as might occur if more than one clock signal or frequency is used.

Distortion

Avoid degrading dynamic performance by choosing an amplifier with distortion much less than the MAX195's THD (-97dB, or 0.0014%) at frequencies of interest. If the chosen amplifier has insufficient common-mode rejection, which results in degraded THD performance, use the inverting configuration (positive input grounded) to eliminate errors from this source. Low temperature-coefficient, gain-setting resistors reduce linearity errors caused by resistance changes due to self-heat-

ing. Also, to reduce linearity errors due to finite amplifier gain, use an amplifier circuit with sufficient loop gain at the frequencies of interest (Figures 14, 15, 16).

DC Accuracy

If DC accuracy is important, choose a buffer with an offset much less than the MAX195's maximum offset ($\pm 3\text{LSB} = \pm 366\mu\text{V}$ for a $\pm 4\text{V}$ input range), or whose offset can be trimmed while maintaining good stability over the required temperature range.

Recommended Circuits

Figure 14 shows a good circuit for DC and low-frequency use. The MAX400 has very low offset ($10\mu\text{V}$) and drift ($0.2\mu\text{V}/^\circ\text{C}$), and low voltage noise ($10\text{nV}/\sqrt{\text{Hz}}$) as well. However, its gain-bandwidth product (GBW) is much too low to drive AIN directly, so the analog input is bypassed to present a low impedance at high frequencies. The large bypass capacitor is isolated from the amplifier output by a 100Ω resistor, which provides additional noise filtering. Since the $\pm 15\text{V}$ supplies exceed the AIN range, add protection diodes at AIN (see *REF and AIN Input Protection* section).

Figure 15 shows a wide-bandwidth amplifier (MAX427) driving a wideband video buffer, which is capable of driving AIN and a small bypass capacitor (for noise reduction) directly. The video buffer is inside the MAX427's feedback loop, providing good DC accuracy, while the buffer's low output impedance and high-current capability provide good AC performance. AIN is diode-clamped to the $\pm 5\text{V}$ rails to prevent overvoltage. The MAX427's $15\mu\text{V}$ maximum offset voltage, $0.8\mu\text{V}/^\circ\text{C}$ maximum drift, and less than $5\text{nV}/\sqrt{\text{Hz}}$ noise specifications make this an excellent choice for AC/DC use.

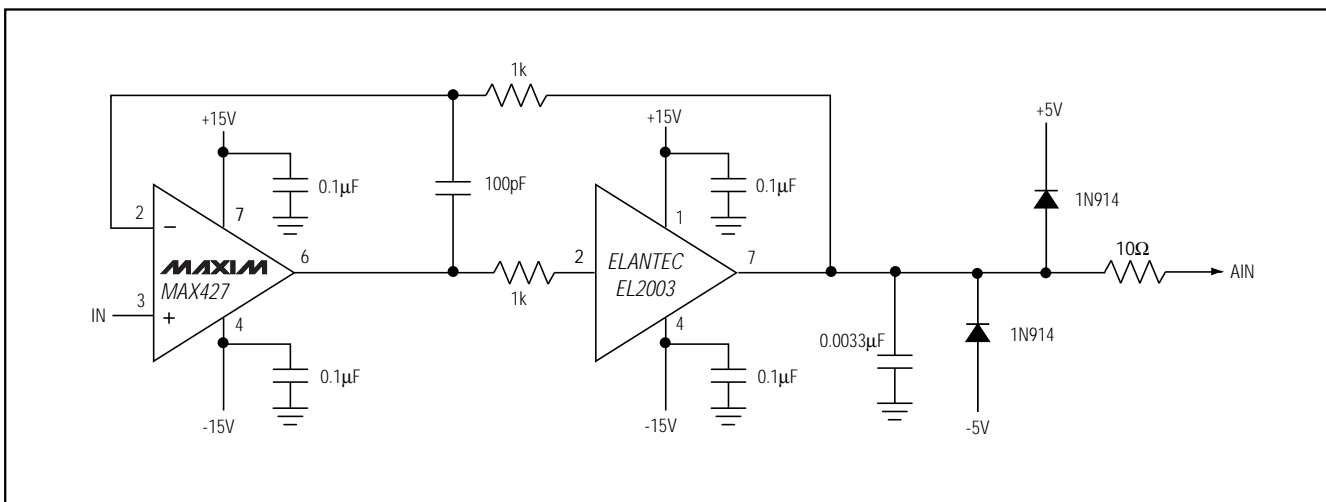

Figure 15. AIN Buffer for AC/DC Use

16-Bit, 85ksps ADC with 10 μ A Shutdown

If $\pm 15\text{V}$ supplies are unavailable, Figure 16's circuit works very well with the $\pm 5\text{V}$ analog supplies used by the MAX195. The MAX410 has a minimum $\pm 3.5\text{V}$ common-mode input range, with a similar output voltage swing, which allows use of a reference voltage up to 3.5V. The offset voltage (250 μV) is about 2LSB. The drift (1 $\mu\text{V}/^\circ\text{C}$), unity-gain bandwidth (28MHz), and low voltage noise (2.4nV/ $\sqrt{\text{Hz}}$) are appropriate for 16-bit performance.

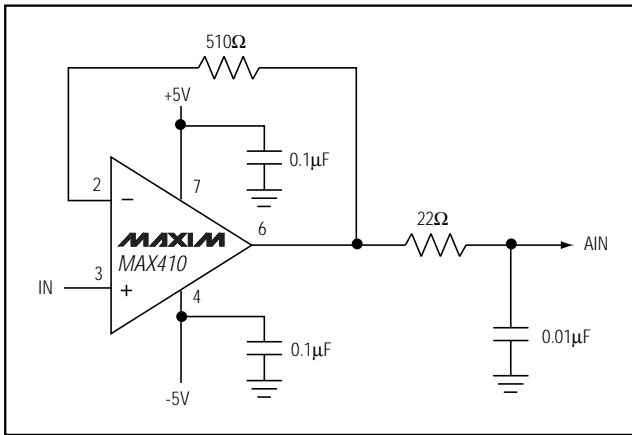

Figure 16. $\pm 5\text{V}$ Buffer for AC/DC Use Has $\pm 3.5\text{V}$ Swing

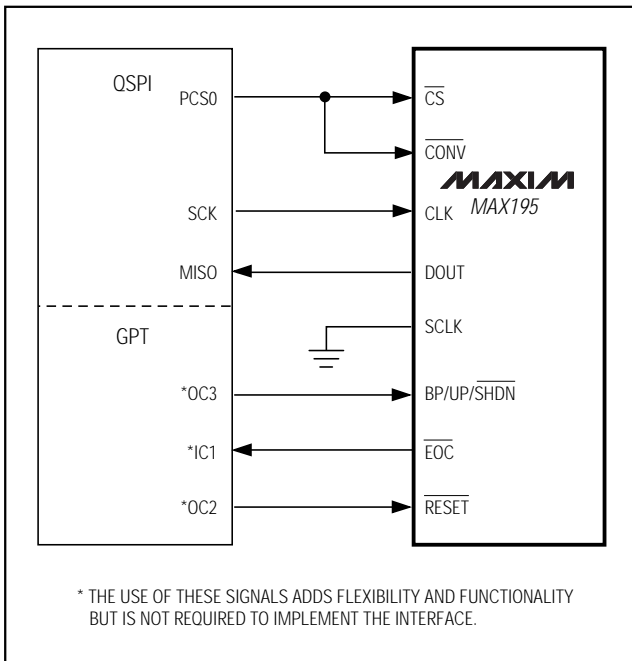

Figure 17. MAX195 Connection to QSPI Processor Clocking Data Out During Conversions

Operating Modes and SPI/QSPI Interfaces
The two basic interface modes are defined according to whether serial data is received during the conversion (clocked with CLK, SCLK unused) or in bursts between conversions (clocked with SCLK). Each mode is presented interfaced to a QSPI processor, but is also compatible with SPI.

Mode 1 (Simultaneous Conversion and Data Transfer)

In this mode, each data bit is read from the MAX195 during the conversion as it is determined. SCLK is grounded and CLK is used as both the conversion clock and the serial data clock. Figure 17 shows a QSPI processor connected to the MAX195 for use in this mode and Figure 18 is the associated timing diagram.

In addition to the standard QSPI interface signals, general I/O lines are used to monitor $\overline{\text{EOC}}$ and to drive BP/UP/SHDN and $\overline{\text{RESET}}$. The two general output pins may not be necessary for a given application and, if I/O lines are unavailable, the $\overline{\text{EOC}}$ connection can be omitted as well.

The $\overline{\text{EOC}}$ signal is monitored during calibration to determine when calibration is finished and before beginning a conversion to ensure the MAX195 is not in mid-conversion, but it is possible for a system to ignore $\overline{\text{EOC}}$ completely. On power-up or after pulsing $\overline{\text{RESET}}$ low, the μP must provide 14,000 CLK cycles to complete the calibration sequence (Figure 2). One way to do this is to toggle CLK and monitor $\overline{\text{EOC}}$ until it goes low, but it is possible to simply count 14,000 CLK cycles to complete the calibration. Similarly, it is unnecessary to check the status of $\overline{\text{EOC}}$ before beginning a conversion if you are sure the last conversion is complete. This can be done by ensuring that every conversion consists of at least 20 CLK cycles.

Data is clocked out of the MAX195 on CLK's falling edge and can be clocked into the μP on the rising edge or the following falling edge. If you clock data in on the rising edge (SPI/QSPI with CPOL = 0 and CPHA = 0; standard MicroWire™: Hitachi H8), the maximum CLK rate is given by:

$$f_{\text{CLK(max)}} = \frac{1}{2} \left(\frac{1}{t_{\text{CD}} + t_{\text{SD}}} \right)$$

where t_{CD} is the MAX195's CLK-to-DOUT valid delay and t_{SD} is the data setup time for your μP .

MicroWire is a trademark of National Semiconductor Corp.

16-Bit, 85ksp/s ADC with 10µA Shutdown

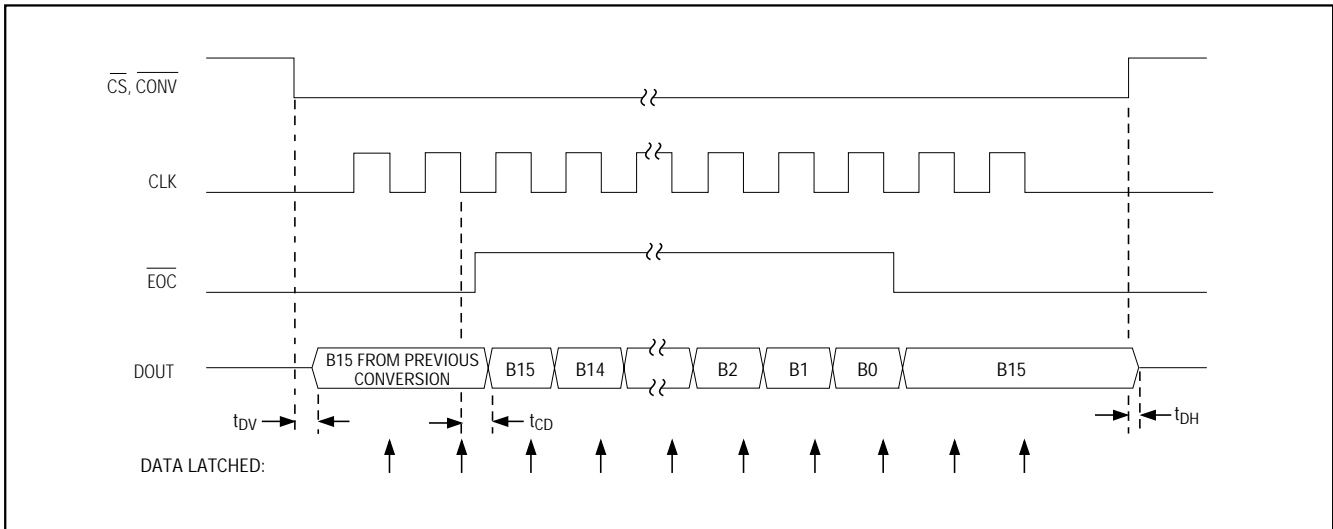

Figure 18. Timing Diagram for Circuit of Figure 17 (Mode 1)

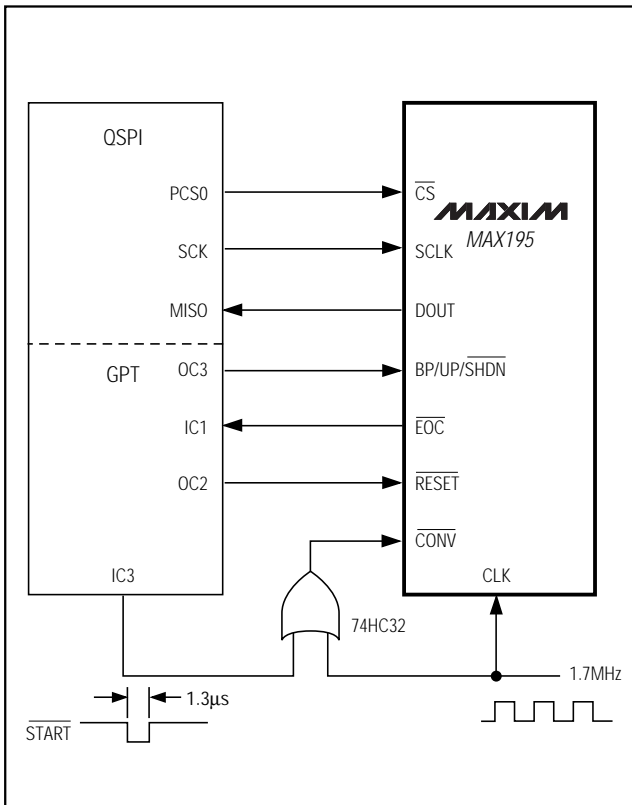

Figure 19. MAX195 Connection to QSPI Processor Clocking Data Out with SCLK Between Conversions

If clocking data in on the falling edge (CPOL = 0, CPHA = 1), the maximum CLK rate is given by:

$$f_{CLK(max)} = \frac{1}{t_{CD} + t_{SD}}$$

Do not exceed the maximum CLK frequency given in the *Electrical Characteristics* table. To clock data in on the falling edge, your processor hold time must not exceed t_{CD} minimum (100ns).

While QSPI can provide the required 20 CLK cycles as two continuous 10-bit transfers, SPI is limited to 8-bit transfers. This means that with SPI, a conversion must consist of three 8-bit transfers. Ensure that the pauses between 8-bit operations at your selected clock rate are short enough to maintain a 20ms or shorter conversion time, or the leakage of the capacitive DAC may cause errors.

Complete source code for the Motorola 68HC16 and the MAX195 evaluation kit (EV kit) using this mode is available with the MAX195 EV kit.

Mode 2 (Asynchronous Data Transfer)

This mode uses a conversion clock (CLK) and a serial clock (SCLK). The serial data is clocked out between conversions, which reduces the maximum throughput for high CLK rates, but may be more convenient for some applications. Figure 19 is a block diagram with a QSPI processor (Motorola 68HC16) connected to the MAX195. Figure 20 shows the associated timing diagram. Figure 21 gives an assembly language listing for this arrangement.

16-Bit, 85ksps ADC with 10 μ A Shutdown

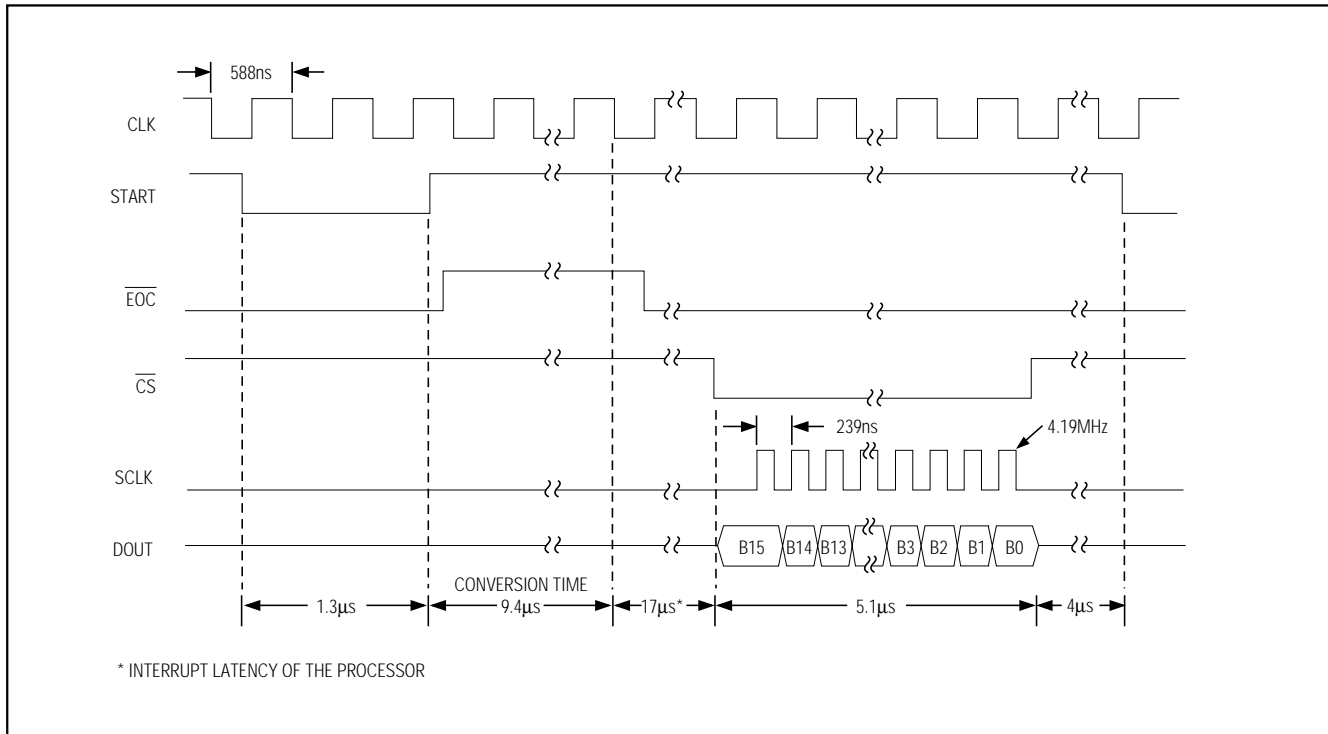

Figure 20. Timing Diagram for Circuit of Figure 19 (Mode 2)

An OR gate is used to synchronize the “start” signal to the asynchronous CLK, as described in the *External Clock* section. As with Mode 1, the QSPI processor must run CLK during calibration and either count CLK cycles or, as is done here, monitor $\overline{\text{EOC}}$ to determine when calibration is complete. Also, $\overline{\text{EOC}}$ is polled by the μP to determine when a conversion result is available. When $\overline{\text{EOC}}$ goes low, data is clocked out at the highest QSPI data rate (4.19Mbps). After the data is transferred, a new conversion can be initiated whenever desired.

The timing specification for SCLK-to-DOUT valid (t_{SD}) imposes some constraints on the serial interface. At SCLK rates up to 2.5Mbps, data is clocked out of the MAX195 by a falling edge of SCLK and may be clocked into the μP by the next rising edge (CPOL = 0, CPHA = 0). For data rates greater than 2.5Mbps (or for lower rates, if desired) it is necessary to clock data out of the MAX195 on SCLK’s falling edge and to clock it into the μP on SCLK’s next falling edge (CPOL = 0, CPHA = 1). Also, your processor hold time must not exceed t_{SD} minimum (20ns). As with CLK in mode 1, maximum SCLK rates may not be possible with some interface specifications that are subsets of SPI.

Supplies, Layout, Grounding and Bypassing

For best system performance, use printed circuit boards with separate analog and digital ground planes. Wire-wrap boards are not recommended. The two ground planes should be tied together at the low-impedance power-supply source and at the MAX195 (Figure 22.) If the analog and digital supplies come from the same source, isolate the digital supply from the analog supply with a low-value resistor (10 Ω).

Constraints on sequencing the four power supplies are as follows.

- Apply VDDA before VDDD.
- Apply VSSA before VSSD.
- Apply AIN and REF after VDDA and VSSA are present.
- The power supplies should settle within the MAX195’s power-on delay (minimum 500ns) or you should recalibrate the converter (pulse $\overline{\text{RESET}}$ low) before use.

16-Bit, 85ksps ADC with 10µA Shutdown

```

*****
* MAX195 code listing for 68HC16 module and circuit of Figure ____ *
* (C) 1994 Maxim Integrated Products *
* *
* Written for use with the Motorola 68HC Macro Assembler - Vers. 4.1 *
* Uses the QSPI in Master mode to read the MAX195. *
*****

*****
*
* Pin assignment for MAX195
*
ShdnPin EQU $20 ; BP/UP = OC3
ResetPin EQU $10 ; RESET = OC2
EOCPin EQU $01 ; /EOC/ = IC1
DoutFrom195 EQU $01 ; DOUT = MISO
SCKto195 EQU $04 ; SCLK = SCK
CSto195 EQU $08 ; /CS/ = PCS0/\SS\
Start EQU $04 ; Start = IC3

*****
*
* QSPI initialization parameters
*
SPBR EQU $2 ; QSPI baud rate = (16.78MHz/(2*SPBR)) = 4.19 MHz
CPOL EQU $0 ; serial clock is low when idle
CPHA EQU $0 ; CPOL=CPHA, so data is valid on rising edge of clock
BITS EQU $10 ; bits per transfer field = 16
DSCKL EQU $2 ; delay before SCK = (DSCKL/16.78MHz) = 119 nsec
DTL EQU $1 ; delay after transfer = (DTL*32/16.78MHz) = 1.19 usec
NEWQP EQU $0 ; pointer to first valid queue entry
ENDQP EQU $1 ; pointer to last valid queue entry

***
* Start of main program *
***

MAIN:

* Initialize the GPT module as a general purpose I/O port
*
; GPT pins that are initially high
;
LDAA #(ResetPin)!(ShdnPin)!(Start)
STAA GPTPDR ; general purpose timer register

; GPT pins that are outputs
;
LDAA #(ResetPin)!(ShdnPin)!(Start)
STAA PDDR ; pin data direction register

* Initialize the QSM / QSPI
*
; list of QSM pins that are high by default
;

```

Figure 21. MAX195 Code Listing for 68HC16 Module and Circuit of Figure 19

16-Bit, 85ksps ADC with 10 μ A Shutdown

```

        LDAA #(CSto195)!(SCKto195)
        STAA QPDR                ; QSPI port data register

        ; list of pins that are assigned to the QSPI
        ;
        LDAA #(CSto195)!(SCKto195)!(DoutFrom195)
        STAA QPAR                ; QSPI pin assignment register

        ; list of QSM pins that are outputs
        ;
        LDAA #(CSto195)!(SCKto195)
        STAA QDDR                ; QSPI data direction register

; QSPI Setup - Master Mode
        CLR  SPCR3                ; disable halt mode interrupt

        LDD  #(((BITS)&$0F)*$0400)!((SPBR)&$FF)!($8000)!((CPOL)*$200)!((CPHA)*$100)
        STD  SPCR0                ; QSPI in master mode,16 bits per transfer,4Mhz baud rate
        ; SCK inactive low, data captured on leading edge of SCK

        LDD  #((DSCCKL&$7F)*$100)!(DTL&$FF)
        STD  SPCR1                ; delay before SCK = 119ns, delay after transfer = 1.19us

; QSPI Setup - No Wrap
        LDD  #((ENDQP&$0F)*$100)!(NEWQP&$0F)
        STD  SPCR2                ; new queue pointer = 0, end queue pointer =1

*****
*
* Reset the MAX195.
*

        BCLR GPTPDR,#ResetPin    ; take MAX195 RESET pin low

WaitHigh1:
        BRCLR GPTPDR,#EOCPin,WaitHigh1    ; wait until EOC goes high

        BSET GPTPDR,#ResetPin    ; take MAX195 RESET pin high

WaitLow1:
        BRSET GPTPDR,#EOCPin,WaitLow1    ; wait until EOC goes low

; prime the ReadMAX195 routine by starting a conversion
; pulse Start pin(IC3), conversion start command; must be externally sync'd with CLK

        BCLR GPTPDR,#Start        ; clear Start, Start is low
        LDAA #2                    ; loop count (delay >= 2/Fclk)
PulseWidth1:
        DECA                        ; decrement loop count
        BNE PulseWidth1
        BSET GPTPDR,#Start        ; set Start, start is high

*****
*
* ReadMAX195:
*

```

Figure 21. MAX195 Code Listing for 68HC16 Module and Circuit of Figure 19 (continued)

16-Bit, 85ksps ADC with 10 μ A Shutdown

```
Loop1:
    BRSET GPTPDR,#EOCPin,Loop1 ; wait until EOC is low

; QSPI Setup - No Wrap
LDD #((ENDQP&$0F)*$100)!(NEWQP&$0F)
STD SPCR2

; QSPI enable
BSETW SPCR1,#$8000
BCLR SPSR,#$80 ; clear QSPI finished flag (SPIF)

WaitForQSPI: ; wait until the QSPI finishes
    BRCLR SPSR,#SPSRSPIF,WaitForQSPI

; start the next conversion
; pulse Start pin (IC3)

    BCLR GPTPDR,#Start ; clear Start, Start is low
    LDAA #2 ; loop count (delay >= 2/Fclk)
PulseWidth2:
    DECA ; decrement loop count
    BNE PulseWidth2
    BSET GPTPDR,#Start ; set Start, Start is high

    LBRA ReadMAX195 ; long branch to ReadMAX195
```

Figure 21. MAX195 Code Listing for 68HC16 Module and Circuit of Figure 19 (continued)

Be sure that digital return currents do not pass through the analog ground and that return-current paths are low impedance. A 5mA current flowing through a PC board ground trace impedance of only 0.05 Ω creates an error voltage of about 250 μ V, or about 2LSBs error with a \pm 4V full-scale system.

The board layout should ensure as much as possible that digital and analog signal lines are kept separate. Do not run analog and digital (especially clock) lines parallel to one another. If you must cross one with the other, do so at right angles.

The ADC's high-speed comparator is sensitive to high-frequency noise on the VDDA and VSSA power supplies. Bypass these supplies to the analog ground plane with 0.1 μ F in parallel with 1 μ F or 10 μ F low-ESR capacitors. Keep capacitor leads short for best supply-noise rejection.

Shutdown

The MAX195 may be shut down by pulling BP/UP/SHDN low. In addition to lowering power dissipation to 10 μ W (100 μ W max) when the device is not in use, you can save considerable power by shutting the converter down for short periods between conversions. There is no need to perform a reset (calibration) after the converter has been shut down unless the time in shutdown

is long enough that the supply voltages or ambient temperature may have changed.

The time required for the converter to "wake up" and settle depends heavily on the amount of additional error acceptable. For 0.5LSB additional error, 3.2 μ s is sufficient settling time and also allows enough time for reacquisition of the analog input signal. 50 μ s settling is required for less than 0.1LSB error. Figure 23 is a graph of theoretical power consumption vs. conversions per second for the MAX195 that assumes the conversion clock is 1.7MHz and the converter is shut down as much as possible between conversions.

Stop CLK before shutting down the MAX195. CLK must be stopped without generating short clock pulses. Short CLK pulses (less than 150ns), or shutting down the MAX195 without stopping CLK, may adversely affect the MAX195's internal calibration data. In applications where CLK is free-running and asynchronous, use the circuit of Figure 24 to stop CLK cleanly.

To minimize the time required to settle and perform a conversion, shut the converter down only after a conversion is finished and the desired mode (unipolar or bipolar) has been set. This ensures that the sampling capacitor array is properly connected to the input signal. If shut down in mid-conversion, when awakened,

16-Bit, 85ksps ADC with 10 μ A Shutdown

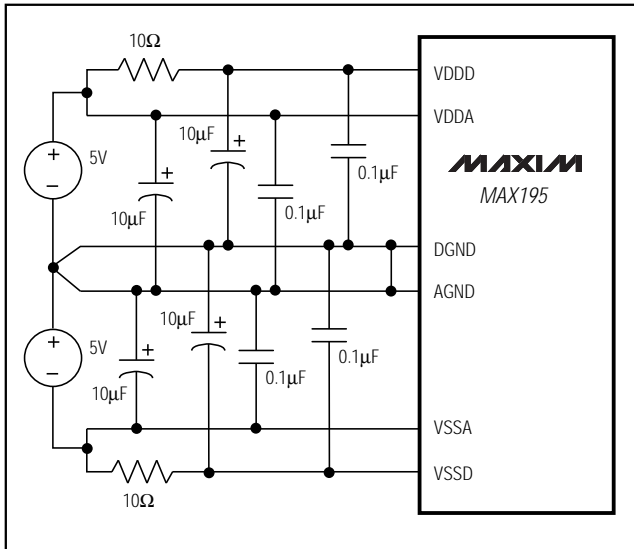

Figure 22. Supply Bypassing and Grounding

the MAX195 finishes the old conversion, allows four clock (CLK) cycles for input acquisition, then begins the new conversion.

Dynamic Performance

High-speed sampling capability, 85ksps throughput, and wide dynamic range make the MAX195 ideal for AC applications and signal processing. To support these and other related applications, Fast Fourier Transform (FFT) test techniques are used to guarantee the ADC's dynamic frequency response, distortion, and noise at the rated throughput. Specifically, this involves applying a low-distortion sine wave to the ADC input and recording the digital conversion results for a specified time. The data is then analyzed using an FFT algorithm, which determines its spectral content. Conversion errors are then seen as spectral elements other than the fundamental input frequency.

Signal-to-Noise Ratio and Effective Number of Bits

Signal-to-Noise Ratio (SNR) is the ratio between the RMS amplitude of the fundamental input frequency to the RMS amplitude of all other ADC output signals. The output band is limited to frequencies above DC and below one-half the ADC sample rate. This usually (but not always) includes distortion as well as noise components. For this reason, the ratio is sometimes referred to as Signal-to-Noise + Distortion (SINAD).

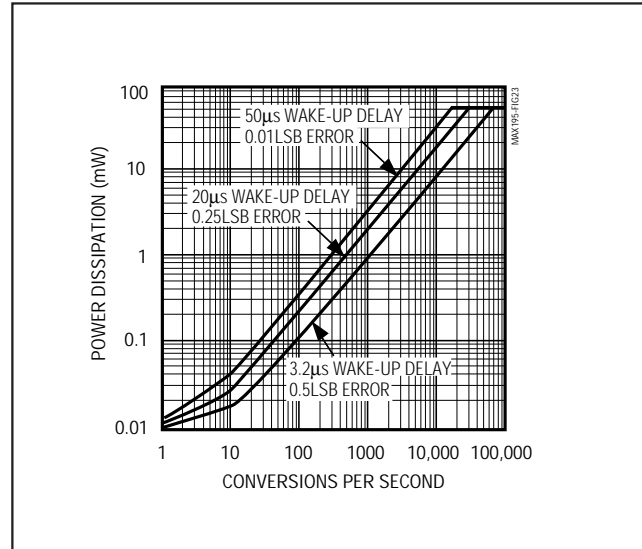

Figure 23. Power Dissipation vs. Conversions/sec When Shutting the MAX195 Down Between Conversions

The theoretical minimum ADC noise is caused by quantization error and is a direct result of the ADC's resolution: $SNR = (6.02N + 1.76)dB$, where N is the number of bits of resolution. A perfect 16-bit ADC can, therefore, do no better than 98dB. An FFT plot of the output shows the output level in various spectral bands. Figure 25 shows the result of sampling a pure 1kHz sinusoid at 85ksps with the MAX195.

By transposing the equation that converts resolution to SNR, we can, from the measured SNR, determine the effective resolution or the "effective number of bits" the ADC provides: $N = (SNR - 1.76) / 6.02$. Substituting SINAD for SNR in this formula results in a better measure of the ADC's usefulness. Figure 26 shows the effective number of bits as a function of the MAX195's input frequency calculated from the SINAD.

If your intended sample rate is much lower than the MAX195's maximum of 85ksps, you can improve your noise performance by taking more samples than necessary (oversampling) and averaging them in software. Figure 27 is a histogram showing 16,384 samples for the MAX195 without averaging, with an ideal "noiseless conversion," and with a running average of five samples. The standard deviation is 0.621LSB without averaging and 0.382LSB with the running average. If fewer data points are needed, normal averaging (e.g., five data points averaged to produce one data point) can be used instead of a running average, with similar results.

16-Bit, 85ksp/s ADC with 10 μ A Shutdown

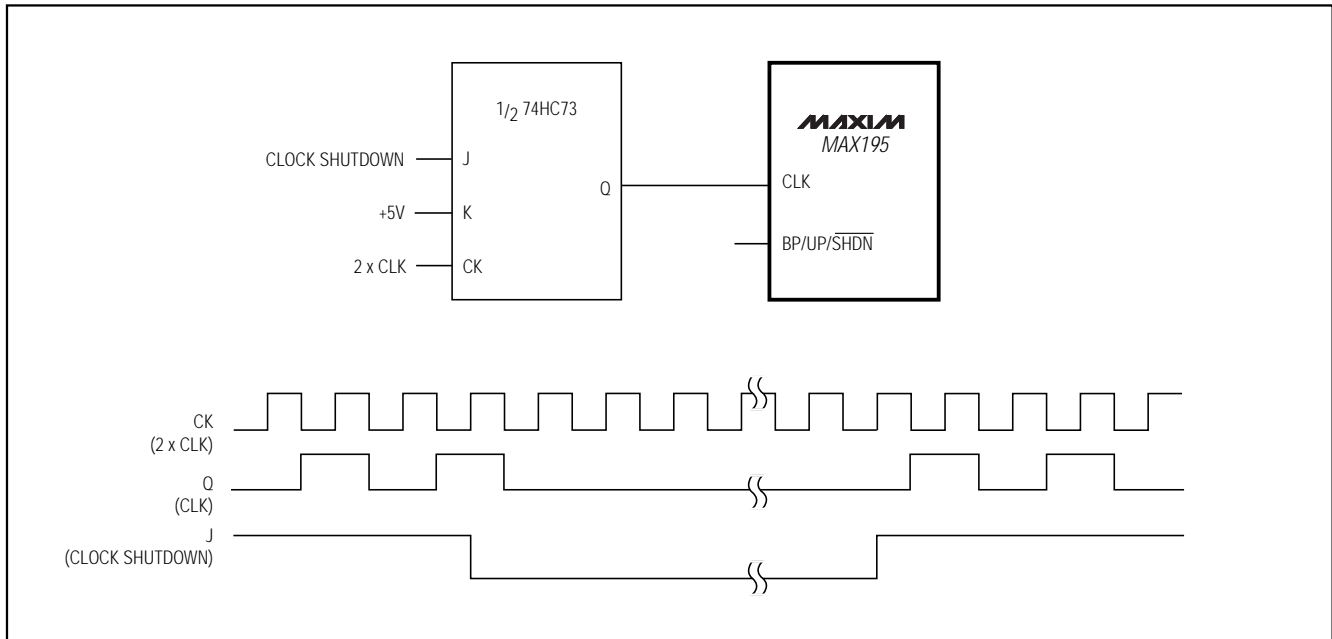

Figure 24. Circuit to Stop Free-Running Asynchronous CLK

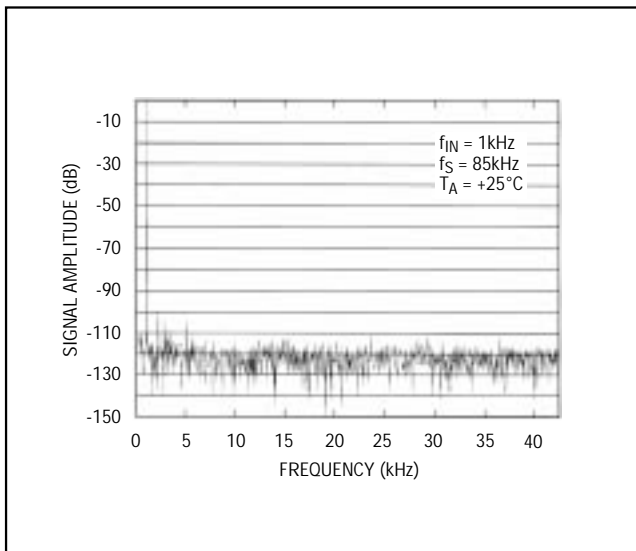

Figure 25. MAX195 FFT Plot

Even better than oversampling and averaging is oversampling and digital filtering. Averaging is just a rough (but computationally simple) type of digital filter. Finite impulse response (and other) digital filter algorithms are readily available, and are useful even with slow processors if the data rate is low or the data does not need to be processed in real-time. When using averaging, be sure to average an odd number of samples to avoid small offset errors caused by asymmetrical rounding.

Whether simple averaging or more complex digital filtering is used, the effect of oversampling is to spread the noise across a wider bandwidth. Digital filtering or averaging then eliminates the portion of this noise that lies above the filter's passband, leaving less noise in the passband than if oversampling was not used. An additional benefit of oversampling is that it simplifies the design or choice of an anti-aliasing pre-filter for the input. You can use a filter with a more gradual rolloff, because the sample rate is much higher than the frequency of interest.

16-Bit, 85ksp/s ADC with 10µA Shutdown

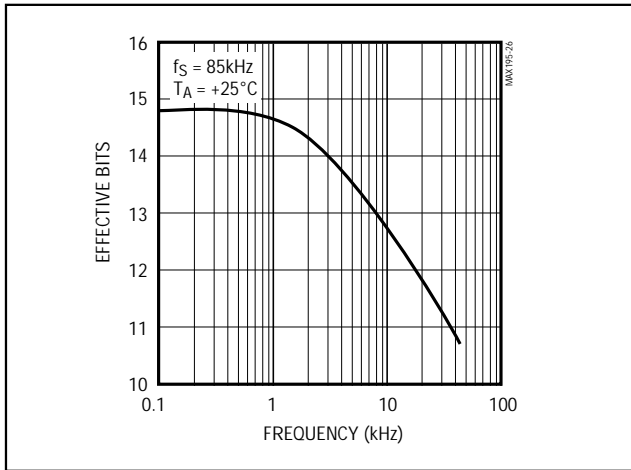

Figure 26. Effective Bits vs. Input Frequency

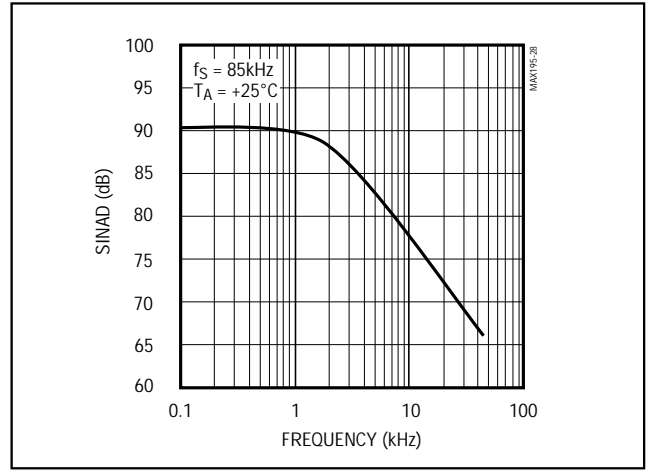

Figure 28. Signal-to-Noise + Distortion vs. Frequency

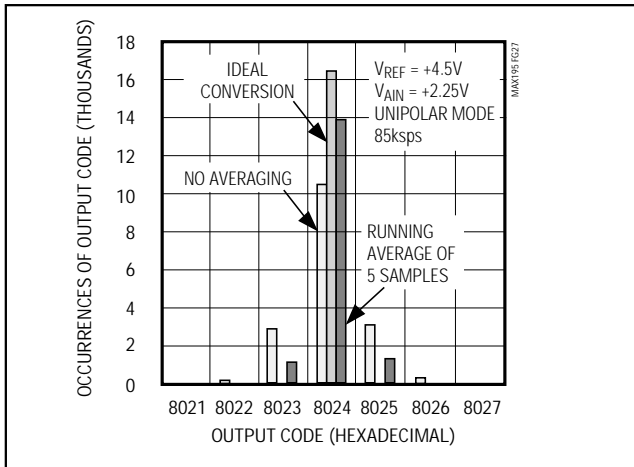

Figure 27. Histogram of 16,384 Conversions Shows Effects of Noise and Averaging

Total Harmonic Distortion

If a pure sine wave is input to an ADC, AC integral non-linearity (INL) of an ADC's transfer function results in harmonics of the input frequency being present in the sampled output data.

Total Harmonic Distortion (THD) is the ratio of the RMS sum of all the harmonics (in the frequency band above DC and below one-half the sample rate, but not including the DC component) to the RMS amplitude of the fundamental frequency.

This is expressed as follows:

$$THD = 20 \log \frac{\sqrt{(V_2^2 + V_3^2 + V_4^2 + \dots + V_N^2)}}{V_1}$$

where V_1 is the fundamental RMS amplitude, and V_2 through V_N are the amplitudes of the 2nd through Nth harmonics. The THD specification in the *Electrical Characteristics* includes the 2nd through 5th harmonics. In the MAX195, this distortion is caused primarily by the changes in on-resistance of the AIN sampling switches with changing input voltage. These resistance changes, together with the DAC's capacitance (which can also vary with input voltage), cause a varying time delay for AC signals, which causes significant distortion at moderately high frequencies (Figure 28).

Spurious-Free Dynamic Range

Spurious-free dynamic range is the ratio of the fundamental RMS amplitude to the amplitude of the next largest spectral component (in the frequency band above DC and below one-half the sample rate). Usually, this peak occurs at some harmonic of the input frequency. However, if the ADC is exceptionally linear, it may occur only at a random peak in the ADC's noise floor.

Transfer Function

Figures 29 and 30 show the MAX195's transfer functions. In unipolar mode, the output data is in binary format and in bipolar mode it is offset binary.

16-Bit, 85ksp/s ADC with 10 μ A Shutdown

MAX195

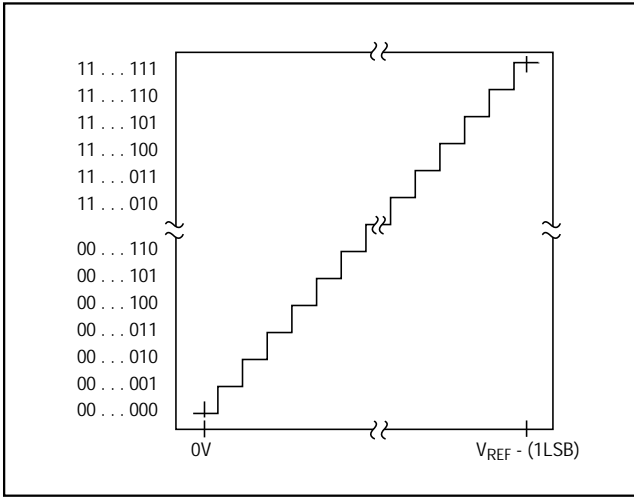

Figure 29. MAX195 Unipolar Transfer Function

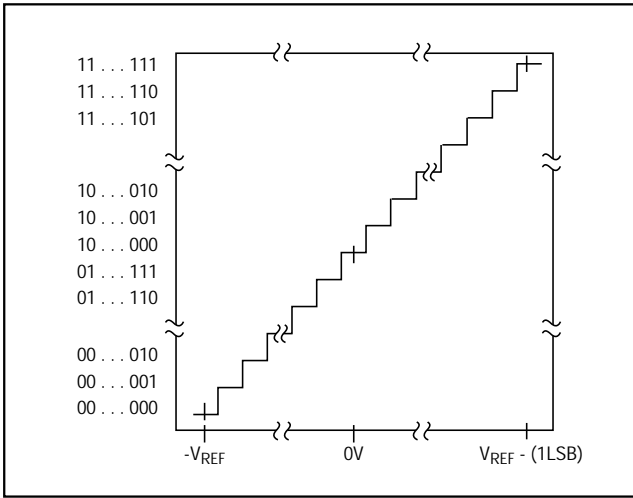
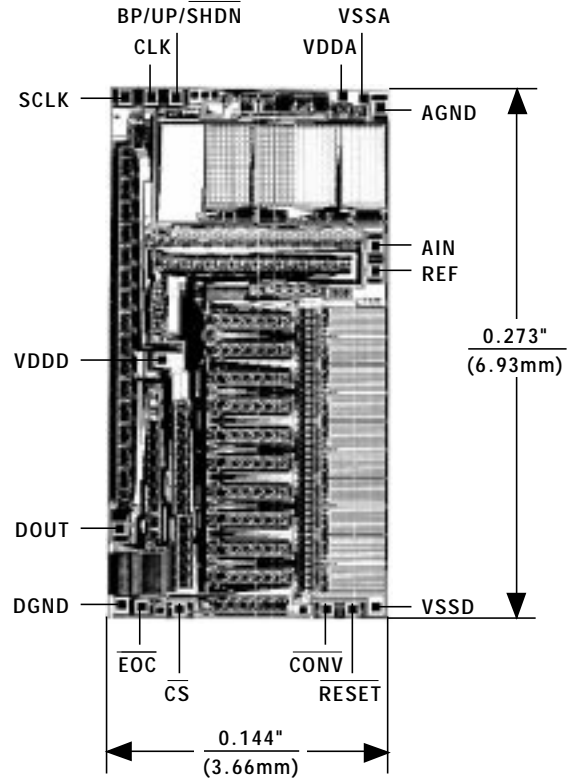

Figure 30. MAX195 Bipolar Transfer Function

Chip Topography



TRANSISTOR COUNT: 7966
SUBSTRATE CONNECTED TO VDDA

16-Bit, 85ksps ADC with 10µA Shutdown

Package Information

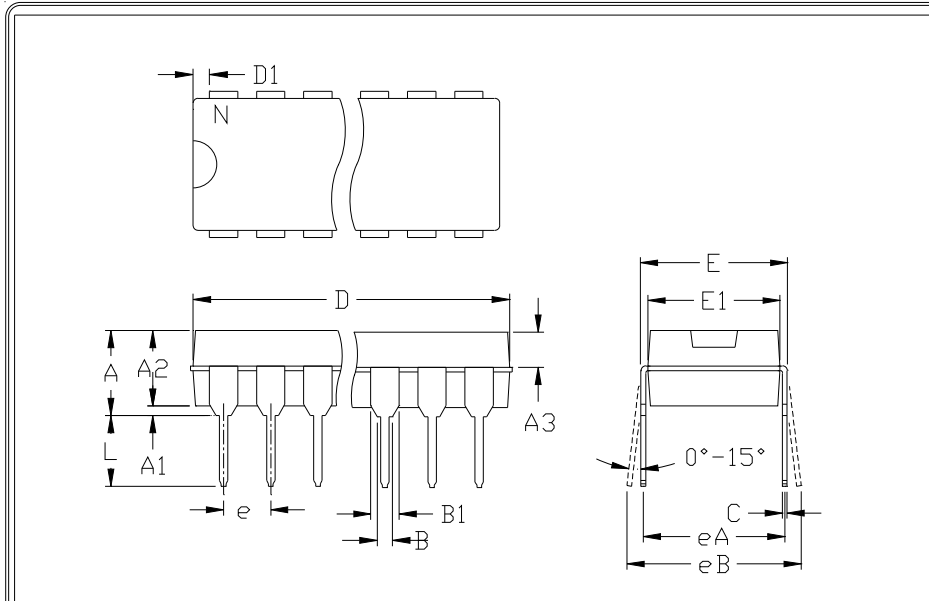

	INCHES		MILLIMETERS	
	MIN	MAX	MIN	MAX
A	---	0.200	---	5.08
A1	0.015	---	0.38	---
A2	0.125	0.175	3.18	4.45
A3	0.055	0.080	1.40	2.03
B	0.016	0.022	0.41	0.56
B1	0.045	0.065	1.14	1.65
C	0.008	0.012	0.20	0.30
D1	0.005	0.080	0.13	2.03
E	0.300	0.325	7.62	8.26
E1	0.240	0.310	6.10	7.87
e	0.100	---	2.54	---
eA	0.300	---	7.62	---
eB	---	0.400	---	10.16
L	0.115	0.150	2.92	3.81

	INCHES		MILLIMETERS		N	MSD01
	MIN	MAX	MIN	MAX		
D	0.348	0.390	8.84	9.91	8	AB
D	0.735	0.765	18.67	19.43	14	AC
D	0.745	0.765	18.92	19.43	16	AA
D	0.885	0.915	22.48	23.24	18	AD
D	1.015	1.045	25.78	26.54	20	AE
D	1.14	1.265	28.96	32.13	24	AF
D	1.360	1.380	34.54	35.05	28	*5

- NOTES:
1. D&E DO NOT INCLUDE MOLD FLASH
 2. MOLD FLASH OR PROTRUSIONS NOT TO EXCEED .15mm (.006")
 3. CONTROLLING DIMENSION: MILLIMETER
 4. MEETS JEDEC MS001-XX AS SHOWN IN ABOVE TABLE
 5. SIMILAR TO JEDEC MO-058AB
 6. N = NUMBER OF PINS



PACKAGE FAMILY OUTLINE: PDIP .300"



21-0043 A
DOCUMENT CONTROL NUMBER REV

16-Bit, 85ksps ADC with 10µA Shutdown

Package Information (continued)

MAX195

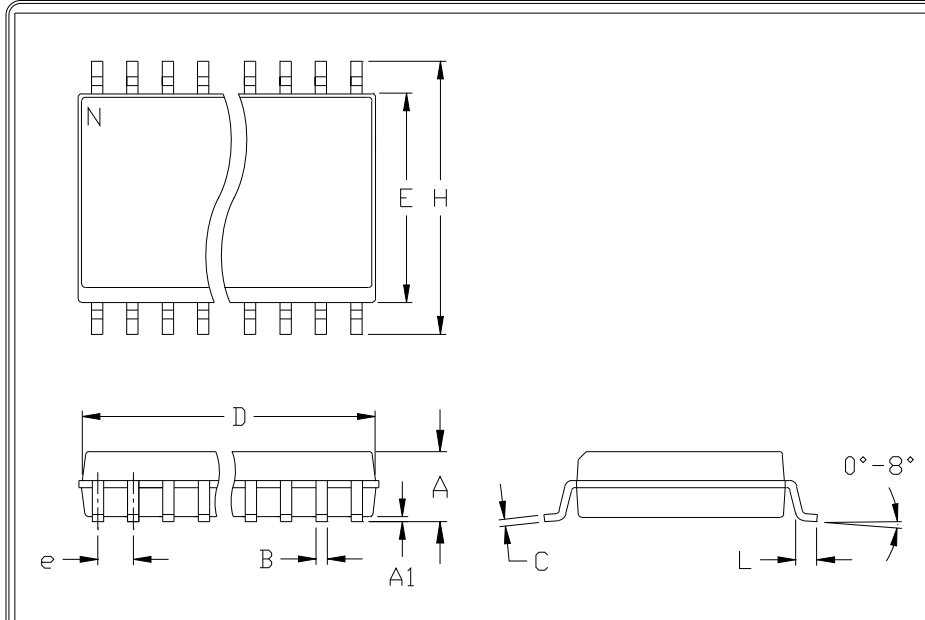

	INCHES		MILLIMETERS	
	MIN	MAX	MIN	MAX
A	0.093	0.104	2.35	2.65
A1	0.004	0.012	0.10	0.30
B	0.014	0.019	0.35	0.49
C	0.009	0.013	0.23	0.32
e	0.050		1.27	
E	0.291	0.299	7.40	7.60
H	0.394	0.419	10.00	10.65
h	0.010	0.030	0.25	0.75
L	0.016	0.050	0.40	1.27

	INCHES		MILLIMETERS		N	MS013
	MIN	MAX	MIN	MAX		
D	0.398	0.413	10.10	10.50	16	AA
D	0.447	0.463	11.35	11.75	18	AB
D	0.496	0.512	12.60	13.00	20	AC
D	0.598	0.614	15.20	15.60	24	AD
D	0.697	0.713	17.70	18.10	28	AE

- NOTES:
1. D&E DO NOT INCLUDE MOLD FLASH
 2. MOLD FLASH OR PROTRUSIONS NOT TO EXCEED .15mm (.006")
 3. LEADS TO BE COPLANAR WITHIN .102mm (.004")
 4. CONTROLLING DIMENSION: MILLIMETER
 5. MEETS JEDEC MS013-XX AS SHOWN IN ABOVE TABLE
 6. N = NUMBER OF PINS

MAXIM
1201 SAN GABRIEL DR. SAN JOAQUIN, CA 94466 FAX (408) 737-7794
PROPRIETARY INFORMATION

PACKAGE FAMILY OUTLINE: SOIC .300" TITLE

1/1

21-0042 A
DOCUMENT CONTROL NUMBER REV

16-Bit, 85ksps ADC with 10µA Shutdown

Package Information (continued)

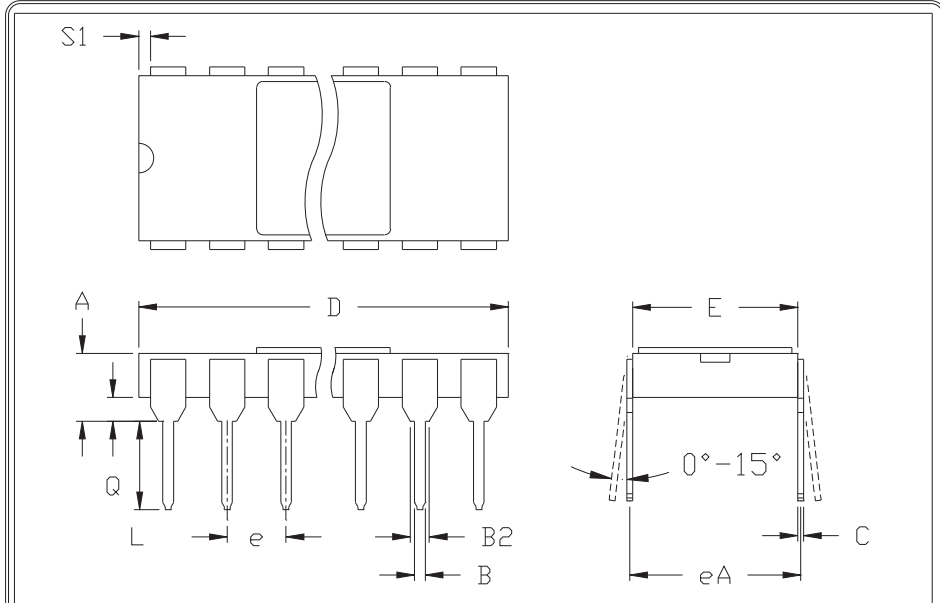

	INCHES		MILLIMETERS	
	MIN	MAX	MIN	MAX
A	---	0.225	---	5.72
B	0.014	0.023	0.36	0.58
B2	0.038	0.065	0.97	1.65
C	0.008	0.015	0.20	0.38
E	0.220	0.310	5.59	7.87
E1	0.290	0.320	7.37	8.13
e	0.100		2.54	
L	0.125	0.200	3.18	5.08
Q	0.015	0.070	0.38	1.78
S1	0.005	---	0.13	---
S2	0.005	---	0.13	---

	INCHES		MILLIMETERS		N	CASE
	MIN	MAX	MIN	MAX		
D	---	0.550	---	13.97	8	*3
D	---	0.785	---	19.94	14	C:D1
D	---	0.840	---	21.34	16	E:D2
D	---	0.960	---	24.38	18	V:D6
D	---	1.060	---	26.92	20	R:D8
D	---	1.280	---	32.51	24	L:D9

- NOTES:
1. CONTROLLING DIMENSION: INCH
 2. MEETS 1835 CASE OUTLINE CONFIGURATION #3 AS SHOWN IN ABOVE TABLE
 3. MEETS 1835 CASE *P*; D-4 CONFIGURATION #3 EXCEPT D AND S1 MAXIMUM DIMENSIONS
 4. N = NUMBER OF PINS

 <small>120 SAN GABRIEL DR. SUNNYVALE CA 94086 FAX (408) 737-7154</small> <small>PROPRIETARY INFORMATION</small>	PACKAGE FAMILY OUTLINE: SIDE BRAZE .300"		21-0047 A
			<small>DOCUMENT CONTROL NUMBER REV.</small>

Maxim cannot assume responsibility for use of any circuitry other than circuitry entirely embodied in a Maxim product. No circuit patent licenses are implied. Maxim reserves the right to change the circuitry and specifications without notice at any time.

28 _____ Maxim Integrated Products, 120 San Gabriel Drive, Sunnyvale, CA 94086 408-737-7600



SITE
SEARCH
PART NO.
SEARCH

WHAT'S NEW PRODUCTS SOLUTIONS DESIGN APPNOTES SUPPORT BUY COMPANY MEMBERS

MAX195

Part Number Table

Notes:

1. See the [MAX195 QuickView Data Sheet](#) for further information on this product family or download the [MAX195 full data sheet](#) (PDF, 320kB).
2. Other options and links for purchasing parts are listed at: <http://www.maxim-ic.com/sales>.
3. [Didn't Find What You Need?](#) Ask our applications engineers. Expert assistance in finding parts, usually within one business day.
4. Part number suffixes: T or T&R = tape and reel; + = RoHS/lead-free; # = RoHS/lead-exempt. More: See [full data sheet](#) or [Part Naming Conventions](#).
5. * Some packages have variations, listed on the drawing. "PkgCode/Variation" tells which variation the product uses.

Part Number	Free Sample	Buy Direct	Package: TYPE PINS SIZE DRAWING CODE/VAR *	Temp	RoHS/Lead-Free? Materials Analysis
MAX195AEWE+T	<input type="checkbox"/>	<input type="checkbox"/>		-40C to +85C	RoHS/Lead-Free: Yes
MAX195AEWE-T	<input type="checkbox"/>	<input type="checkbox"/>		-40C to +85C	RoHS/Lead-Free: No
MAX195BC/D	<input type="checkbox"/>	<input type="checkbox"/>			RoHS/Lead-Free: No
MAX195BEPE+	<input type="checkbox"/>	<input type="checkbox"/>	PDIP;16 pin;.300" Dwg: 21-0043D (PDF) Use pkgcode/variation: P16+8*	-40C to +85C	RoHS/Lead-Free: Yes Materials Analysis
MAX195BCPE+	<input type="checkbox"/>	<input type="checkbox"/>	PDIP;16 pin;.300" Dwg: 21-0043D (PDF) Use pkgcode/variation: P16+8*	0C to +70C	RoHS/Lead-Free: Yes Materials Analysis
MAX195BCPE	<input type="checkbox"/>	<input type="checkbox"/>	PDIP;16 pin;.300" Dwg: 21-0043D (PDF) Use pkgcode/variation: P16-8*	0C to +70C	RoHS/Lead-Free: No Materials Analysis
MAX195BEPE	<input type="checkbox"/>	<input type="checkbox"/>	PDIP;16 pin;.300" Dwg: 21-0043D (PDF) Use pkgcode/variation: P16-8*	-40C to +85C	RoHS/Lead-Free: No Materials Analysis

MAX195AEDE				-40C to +85C	RoHS/Lead-Free: No
MAX195ACDE			SideBraze;16 pin;.300" Dwg: 21-0047B (PDF) Use pkgcode/variation: D16-3*	0C to +70C	RoHS/Lead-Free: No Materials Analysis
MAX195BMDE			SideBraze;16 pin;.300" Dwg: 21-0047B (PDF) Use pkgcode/variation: D16-3*	-55C to +125C	RoHS/Lead-Free: No Materials Analysis
MAX195AMDE			SideBraze;16 pin;.300" Dwg: 21-0047B (PDF) Use pkgcode/variation: D16-3*	-55C to +125C	RoHS/Lead-Free: No Materials Analysis
MAX195ACWE-T				0C to +70C	RoHS/Lead-Free: No
MAX195ACWE			SOIC;16 pin;.300" Dwg: 21-0042B (PDF) Use pkgcode/variation: W16-6*	0C to +70C	RoHS/Lead-Free: No Materials Analysis
MAX195ACWE+T				0C to +70C	RoHS/Lead-Free: Yes
MAX195ACWE+			SOIC;16 pin;.300" Dwg: 21-0042B (PDF) Use pkgcode/variation: W16+6*	0C to +70C	RoHS/Lead-Free: Yes Materials Analysis
MAX195BCWE			SOIC;16 pin;.300" Dwg: 21-0042B (PDF) Use pkgcode/variation: W16-6*	0C to +70C	RoHS/Lead-Free: No Materials Analysis
MAX195BCWE+			SOIC;16 pin;.300" Dwg: 21-0042B (PDF) Use pkgcode/variation: W16+6*	0C to +70C	RoHS/Lead-Free: Yes Materials Analysis
MAX195BCWE+T			SOIC;16 pin;.300" Dwg: 21-0042B (PDF) Use pkgcode/variation: W16+6*	0C to +70C	RoHS/Lead-Free: Yes Materials Analysis
MAX195BCWE-T			SOIC;16 pin;.300" Dwg: 21-0042B (PDF) Use pkgcode/variation: W16-6*	0C to +70C	RoHS/Lead-Free: No Materials Analysis
MAX195BEWE+T			SOIC;16 pin;.300" Dwg: 21-0042B (PDF) Use pkgcode/variation: W16+6*	-40C to +85C	RoHS/Lead-Free: Yes Materials Analysis
MAX195BEWE+			SOIC;16 pin;.300" Dwg: 21-0042B (PDF) Use pkgcode/variation: W16+6*	-40C to +85C	RoHS/Lead-Free: Yes Materials Analysis
MAX195BEWE			SOIC;16 pin;.300" Dwg: 21-0042B (PDF) Use pkgcode/variation: W16-6*	-40C to +85C	RoHS/Lead-Free: No Materials Analysis
MAX195BEWE-T			SOIC;16 pin;.300" Dwg: 21-0042B (PDF) Use pkgcode/variation: W16-6*	-40C to +85C	RoHS/Lead-Free: No Materials Analysis

MAX195AEWE	<input type="text"/>	<input type="text"/>		-40C to +85C	RoHS/Lead-Free: No
MAX195AEWE+	<input type="text"/>	<input type="text"/>		-40C to +85C	RoHS/Lead-Free: Yes

[Didn't Find What You Need?](#)

[CONTACT US: SEND US AN EMAIL](#)

Copyright 2007 by Maxim Integrated Products, Dallas Semiconductor • [Legal Notices](#) • [Privacy Policy](#)