

RF-Hardened, Low-Noise Microphone with Top Port and Analog Output

GENERAL DESCRIPTION

The ICS-40181 is an analog MEMS microphone with high SNR and enhanced RF immunity. The ICS-40181 includes a MEMS microphone element, an impedance converter, and an output amplifier.

Other high-performance specification include a linear response up to 124 dB SPL, tight ± 1 dB sensitivity tolerance and enhanced immunity to both radiated and conducted RF interference.

This microphone's electro-acoustic performance matches the bottom port ICS-40180, making this pair of microphones suitable to use together in applications requiring both top and bottom port devices.

The ICS-40181 is available in a small 3.5 mm \times 2.65 mm \times 0.98 mm surface-mount package.

APPLICATIONS

- Smartphones
- Tablet Computers
- Wearable Devices
- Still and Video Cameras
- Bluetooth Headsets
- Notebook PCs
- Security and Surveillance

FEATURES

- High 65 dBA SNR
- -38 dBV Sensitivity
- ± 1 dB Sensitivity Tolerance
- Noninverted Signal Output
- Omnidirectional Response
- Extended Frequency Response from 60 Hz to 20 kHz
- Enhanced RF Immunity
- 124 dB SPL Acoustic Overload Point
- Low Current Consumption of 180 μ A
- Single-Ended Analog Output
- High -78 dBV PSR
- 3.5 \times 2.65 \times 0.98 mm Surface-Mount Package
- Compatible with Sn/Pb and Pb-Free Solder Processes
- RoHS/WEEE Compliant

FUNCTIONAL BLOCK DIAGRAM

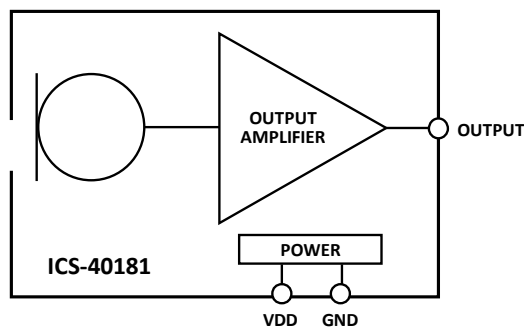

ORDERING INFORMATION

PART	TEMP RANGE	PACKAGING
ICS-40181	-40°C to $+85^{\circ}\text{C}$	13" Tape and Reel
EV_IC3-40181-FX	—	

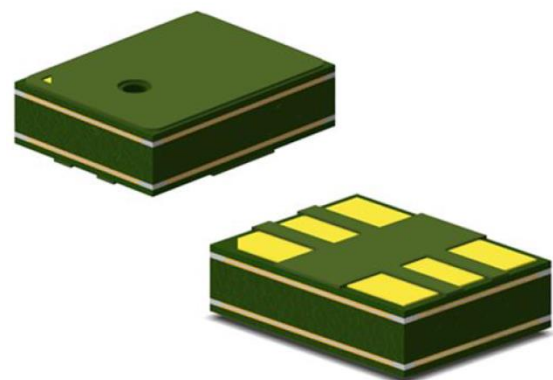

TABLE OF CONTENTS

General Description 1

Applications 1

Features 1

Functional Block Diagram 1

Ordering Information 1

Table of Contents 2

Specifications 3

 Table 1. Electrical Characteristics 3

Absolute Maximum Ratings 4

 Table 2. Absolute Maximum Ratings 4

 ESD Caution 4

 Soldering Profile 5

 Table 3. Recommended Soldering Profile* 5

Pin Configurations And Function Descriptions 6

 Table 4. Pin Function Descriptions 6

Typical Performance Characteristics 7

Applications Information 8

 Codec Connection 8

Supporting Documents 9

 Evaluation Board User Guide 9

 Application Notes 9

PCB Design And Land Pattern Layout 10

 PCB Material And Thickness 10

Handling Instructions 11

 Pick And Place Equipment 11

 Reflow Solder 11

 Board Wash 11

Outline Dimensions 12

 Ordering Guide 13

 Revision History 13

Compliance Declaration Disclaimer 14

SPECIFICATIONS

TABLE 1. ELECTRICAL CHARACTERISTICS

(T_A = -40 to 85°C, V_{DD} = 1.5 to 3.63 V, unless otherwise noted. All minimum and maximum specifications are guaranteed across temperature and voltage specified in Table 1, unless otherwise noted. Typical specifications are not guaranteed.)

PARAMETER	CONDITIONS	MIN	TYP	MAX	UNITS	NOTES
PERFORMANCE						
Directionality			Omni			
Output Polarity		Non-Inverted				
Sensitivity	1 kHz, 94 dB SPL, differential	-39	-38	-37	dBV	1
NORMAL MODE PERFORMANCE						
Signal-to-Noise Ratio (SNR)	20 Hz to 20 kHz, A-weighted		65		dB	
Equivalent Input Noise (EIN)	20 Hz to 20 kHz, A-weighted		29		dB SPL	
Dynamic Range	Derived from EIN and maximum acoustic input		95		dB	
Frequency Response	Low frequency -3 dB point		60		Hz	2
	High frequency -3 dB point		>20		kHz	
Total Harmonic Distortion (THD)	105 dB SPL		0.2	1	%	
Power-Supply Rejection (PSR)	217 Hz, 100 mVp-p square wave superimposed on V _{DD} = 1.8 V		-78		dBV	
Power Supply Rejection Ratio (PSRR)	1 kHz, 100 mV p-p sine wave superimposed on V _{DD} = 1.8 V		-46		dB	
Acoustic Overload Point	10% THD		124		dB SPL	
POWER SUPPLY						
Supply Voltage (V _{DD})	Normal Mode	1.5		3.63	V	
Supply Current (I _s)	V _{DD} = 1.8 V		180	220	μA	
	V _{DD} = 3.3 V		210	250	μA	
OUTPUT CHARACTERISTICS						
Output Impedance			350		Ω	
Output DC Offset			0.7		V	
Maximum Output Voltage	124 dB SPL input		0.398		V rms	
Noise Floor	20 Hz to 20 kHz, A-weighted, rms		-103		dBV	

Note 1: The sensitivity shall not deviate more than 1.5 dB from its initial value after reliability tests.

Note 2: See Figure 3 and Figure 4 .

ABSOLUTE MAXIMUM RATINGS

Stress above those listed as Absolute Maximum Ratings may cause permanent damage to the device. These are stress ratings only and functional operation of the device at these conditions is not implied. Exposure to the absolute maximum ratings conditions for extended periods may affect device reliability.

TABLE 2. ABSOLUTE MAXIMUM RATINGS

PARAMETER	RATING
Supply Voltage (V_{DD})	-0.3 V to +3.63 V
Sound Pressure Level	160 dB
Mechanical Shock	10,000 <i>g</i>
Vibration	Per MIL-STD-883 Method 2007, Test Condition B
Temperature Range	
Biased	-40°C to +85°C
Storage	-55°C to +150°C

ESD CAUTION



ESD (electrostatic discharge) sensitive device. Charged devices and circuit boards can discharge without detection. Although this product features patented or proprietary protection circuitry, damage may occur on devices subjected to high energy ESD. Therefore proper ESD precautions should be taken to avoid performance degradation or loss of functionality.

SOLDERING PROFILE

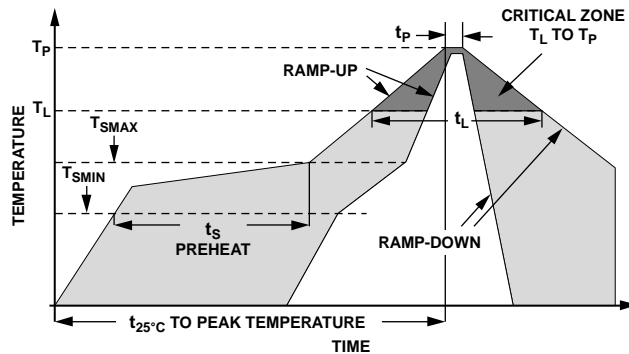

Figure 1. Recommended Soldering Profile Limits

TABLE 3. RECOMMENDED SOLDERING PROFILE*

PROFILE FEATURE		Sn63/Pb37	Pb-Free
Average Ramp Rate (T_L to T_P)		1.25°C/sec max	1.25°C/sec max
Preheat	Minimum Temperature (T_{SMIN})	100°C	100°C
	Minimum Temperature (T_{SMIN})	150°C	200°C
	Time (T_{SMIN} to T_{SMAX}), t_s	60 sec to 75 sec	60 sec to 75 sec
Ramp-Up Rate (T_{SMAX} to T_L)		1.25°C/sec	1.25°C/sec
Time Maintained Above Liquidous (t_L)		45 sec to 75 sec	~50 sec
Liquidous Temperature (T_L)		183°C	217°C
Peak Temperature (T_P)		215°C +3°C/-3°C	260°C +0°C/-5°C
Time Within +5°C of Actual Peak Temperature (t_p)		20 sec to 30 sec	20 sec to 30 sec
Ramp-Down Rate		3°C/sec max	3°C/sec max
Time +25°C ($t_{25^\circ\text{C}}$) to Peak Temperature		5 min max	5 min max

*The reflow profile in Table 3 is recommended for board manufacturing with InvenSense MEMS microphones. All microphones are also compatible with the J-STD-020 profile

PIN CONFIGURATIONS AND FUNCTION DESCRIPTIONS

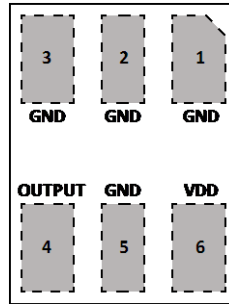

Figure 2. Pin Configuration (Top View, Terminal Side Down)

TABLE 4. PIN FUNCTION DESCRIPTIONS

PIN	NAME	FUNCTION
1	GND	Ground
2	GND	Ground
3	GND	Ground
4	OUTPUT	Analog Output Signal
5	GND	Ground
6	VDD	Power Supply. Decouple to GND pin with 0.1 μ F capacitor

TYPICAL PERFORMANCE CHARACTERISTICS

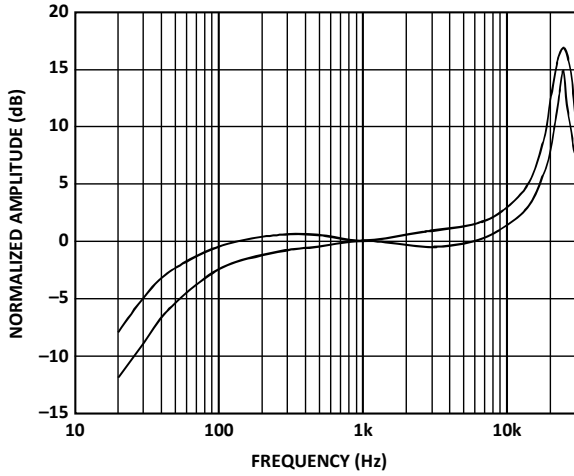

Figure 3. Frequency Response Mask

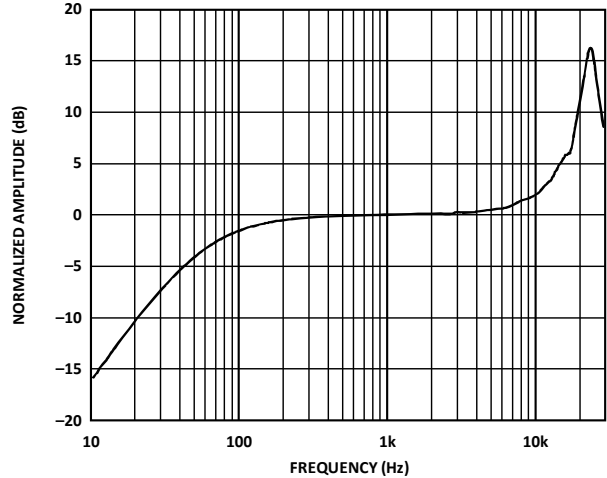

Figure 4. Typical Frequency Response (Measured)

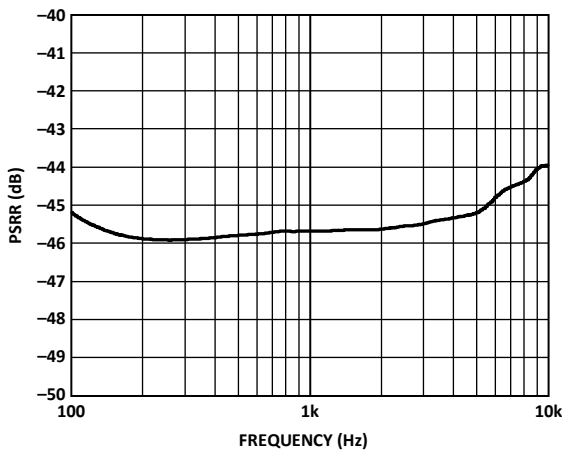

Figure 5. PSR vs. Frequency, 100 mV p-p Swept Sine Wave

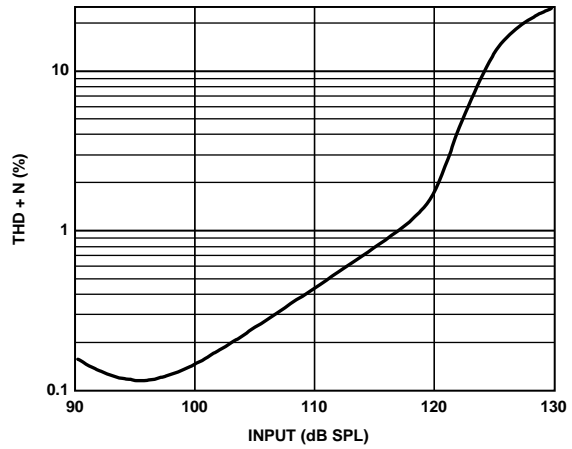

Figure 6. Total Harmonic Distortion + Noise (THD+N) vs. Input SPL

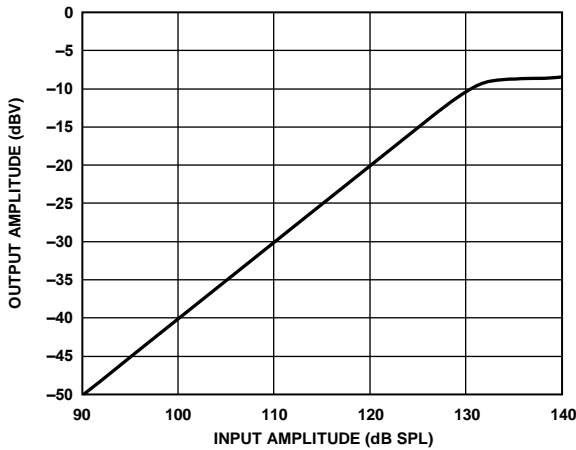

Figure 7. Linearity

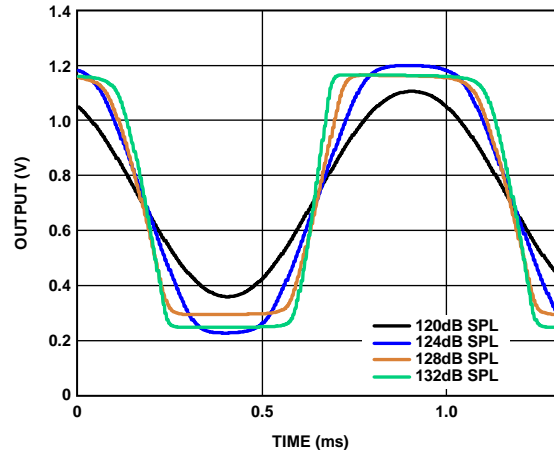

Figure 8. Clipping Characteristics

APPLICATIONS INFORMATION

CODEC CONNECTION

The ICS-40181 output can be connected to a dedicated codec microphone input (see Figure 9) or to a high input impedance gain stage. A 0.1 μF ceramic capacitor placed close to the ICS-40181 supply pin is used for testing and is recommended to adequately decouple the microphone from noise on the power supply. A DC blocking capacitor is required at the output of the microphone. This capacitor creates a high-pass filter with a corner frequency at

$$f_c = 1/(2\pi \times C \times R)$$

where, *R* is the input impedance of the codec.

A minimum value of 2.2 μF is recommended in Figure 9 because the input impedance of some codecs can be as low as 2 kΩ at their highest PGA gain setting, which results in a high-pass filter corner frequency at 37 Hz. Figure 10 shows the ICS-40181 connected to an op amp configured as a noninverting preamplifier.

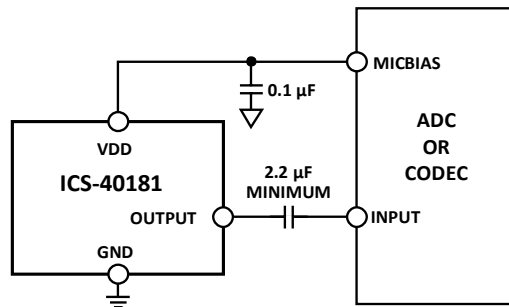

Figure 9. ICS-40181 Connected to a Codec

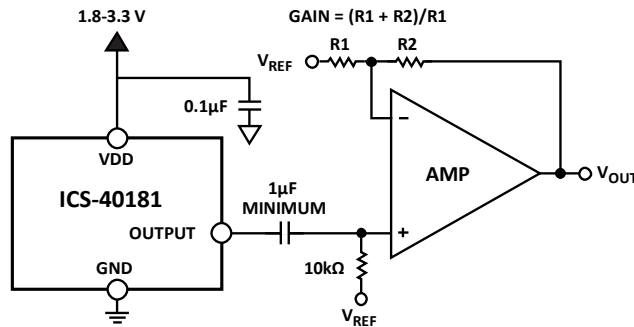

Figure 10. ICS-40181 Connected to an Op Amp

SUPPORTING DOCUMENTS

For additional information, see the following documents.

EVALUATION BOARD USER GUIDE

UG-325, *Analog Output MEMS Microphone Flex Evaluation Board*

APPLICATION NOTES

AN-100, *MEMS Microphone Handling and Assembly Guide*

AN-1003, *Recommendations for Mounting and Connecting the InvenSense Bottom-Ported MEMS Microphones*

AN-1112, *Microphone Specifications Explained*

AN-1124, *Recommendations for Sealing InvenSense Bottom-Port MEMS Microphones from Dust and Liquid Ingress*

AN-1140, *Microphone Array Beamforming*

AN-1165, *Op Amps for Microphone Preamp Circuits*

AN-1181, *Using a MEMS Microphone in a 2-Wire Microphone Circuit*

PCB DESIGN AND LAND PATTERN LAYOUT

Lay out the PCB land pattern for the ICS-40181 at a 1:1 ratio to the solder pads on the microphone package (see Figure 11.) Figure 12 shows a suggested solder paste stencil pattern layout.

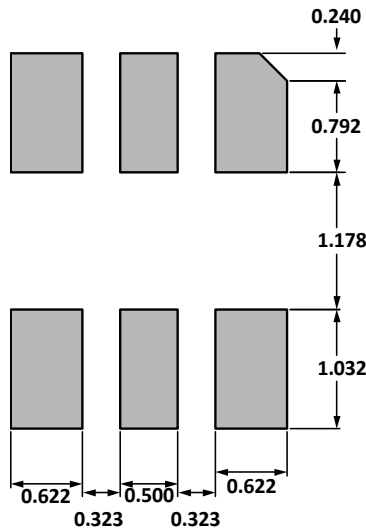

Figure 11. Recommended PCB Land Pattern Layout

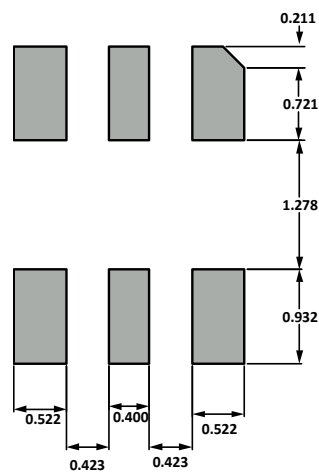

Figure 12. Recommended Solder Paste Stencil Pattern Layout

PCB MATERIAL AND THICKNESS

The ICS-40181 can be mounted on either a rigid or flexible PCB. A microphone’s lid can be attached directly to the device housing with an adhesive layer. This mounting method offers a reliable seal around the sound port while providing the shortest acoustic path for good sound quality. The sound port can also be routed to the device housing through a port in a rubber boot. This boot should be designed to seal the connection between the microphone’s lid and the rubber completely.

HANDLING INSTRUCTIONS

PICK AND PLACE EQUIPMENT

The MEMS microphone can be handled using standard pick-and-place and chip shooting equipment. Take care to avoid damage to the MEMS microphone structure as follows:

- Use a standard pickup tool to handle the microphone. Because the microphone hole is on the top of the package, the pickup tool should not be placed over the microphone port.
- Do not pull air out of or blow air into the microphone port.
- Do not use excessive force to place the microphone on the PCB.

REFLOW SOLDER

For best results, the soldering profile must be in accordance with the recommendations of the manufacturer of the solder paste used to attach the MEMS microphone to the PCB. It is recommended that the solder reflow profile not exceed the limit conditions specified in Figure 1 and Table 3.

BOARD WASH

When washing the PCB, ensure that water does not make contact with the microphone port. Do not use blow-off procedures or ultrasonic cleaning.

OUTLINE DIMENSIONS

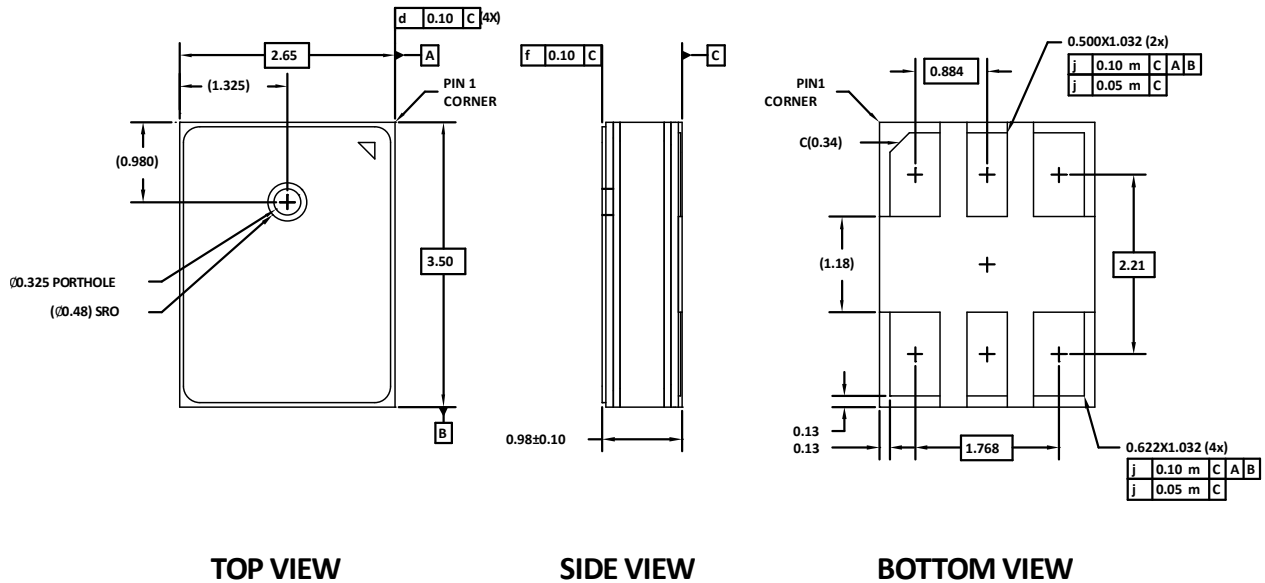

Figure 13. 6-Terminal Chip Array Small Outline No-Lead Cavity
3.50 mm × 2.65 mm × 0.98 mm Body
Dimensions shown in millimeters

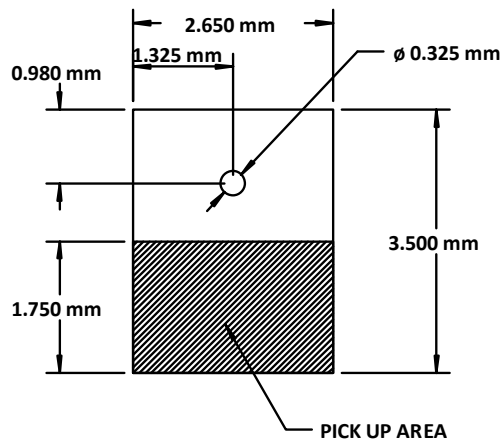

Figure 14. Recommended Vacuum Pick-up Area

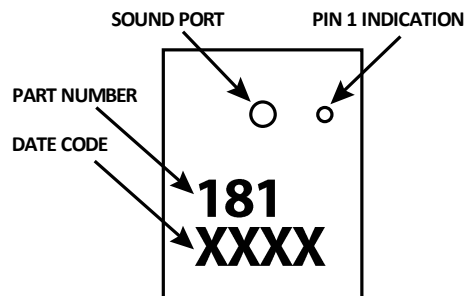

Figure 15. Package Marking Specification (Top View)

ORDERING GUIDE

PART	TEMP RANGE	PACKAGE	QUANTITY	PACKAGING
ICS-40181	-40°C to +85°C	6-Terminal LGA_CAV	10,000	13" Tape and Reel
EV_ICs-40181-FX	—	Flexible Evaluation Board	—	

REVISION HISTORY

REVISION DATE	REVISION	DESCRIPTION
3/23/2015	1.0	Initial Version
4/27/2015	1.1	Updated Figures 3 and 4
07/15/2015	1.2	Added Note 1 to Table 1

COMPLIANCE DECLARATION DISCLAIMER

InvenSense believes the environmental and other compliance information given in this document to be correct but cannot guarantee accuracy or completeness. Conformity documents substantiating the specifications and component characteristics are on file. InvenSense subcontracts manufacturing, and the information contained herein is based on data received from vendors and suppliers, which has not been validated by InvenSense.

This information furnished by InvenSense is believed to be accurate and reliable. However, no responsibility is assumed by InvenSense for its use, or for any infringements of patents or other rights of third parties that may result from its use. Specifications are subject to change without notice. InvenSense reserves the right to make changes to this product, including its circuits and software, in order to improve its design and/or performance, without prior notice. InvenSense makes no warranties, neither expressed nor implied, regarding the information and specifications contained in this document. InvenSense assumes no responsibility for any claims or damages arising from information contained in this document, or from the use of products and services detailed therein. This includes, but is not limited to, claims or damages based on the infringement of patents, copyrights, mask work and/or other intellectual property rights.

Certain intellectual property owned by InvenSense and described in this document is patent protected. No license is granted by implication or otherwise under any patent or patent rights of InvenSense. This publication supersedes and replaces all information previously supplied. Trademarks that are registered trademarks are the property of their respective companies. InvenSense sensors should not be used or sold in the development, storage, production or utilization of any conventional or mass-destructive weapons or for any other weapons or life threatening applications, as well as in any other life critical applications such as medical equipment, transportation, aerospace and nuclear instruments, undersea equipment, power plant equipment, disaster prevention and crime prevention equipment.

©2015 InvenSense, Inc. All rights reserved. InvenSense, MotionTracking, MotionProcessing, MotionProcessor, MotionFusion, MotionApps, DMP, AAR and the InvenSense logo are trademarks of InvenSense, Inc. Other company and product names may be trademarks of the respective companies with which they are associated.



©2015 InvenSense, Inc. All rights reserved.