



NuMicro™ Family NUC123 Series Data Sheet

The information described in this document is the exclusive intellectual property of Nuvoton Technology Corporation and shall not be reproduced without permission from Nuvoton.

Nuvoton is providing this document only for reference purposes of NuMicro microcontroller based system design. Nuvoton assumes no responsibility for errors or omissions.

All data and specifications are subject to change without notice.

For additional information or questions, please contact: Nuvoton Technology Corporation.

www.nuvoton.com



TABLE OF CONTENTS

TABLE OF CONTENTS	2
LIST OF FIGURES	5
LIST OF TABLES	6
1 GENERAL DESCRIPTION	7
2 FEATURES	8
2.1 NuMicro™ NUC123 Features.....	8
3 PARTS INFORMATION LIST AND PIN CONFIGURATION	12
3.1 NuMicro™ NUC123xxxANx Selection Guide	12
3.1.1 NuMicro™ NUC123 Selection Guide	12
3.2 Pin Configuration	13
3.2.1 NuMicro™ NUC123 Pin Diagram.....	13
3.2.2 Pin Description	16
3.2.3 NuMicro™ NUC123 Pin Description	16
4 BLOCK DIAGRAM	22
4.1 NuMicro™ NUC123 Block Diagram	22
4.1.1 NuMicro™ NUC123 Block Diagram	22
5 FUNCTIONAL DESCRIPTION.....	23
5.1 Memory Organization	23
5.1.1 Overview	23
5.1.2 System Memory Map.....	24
5.2 Nested Vectored Interrupt Controller (NVIC).....	26
5.2.1 Overview	26
5.2.2 Features	26
5.2.3 Exception Model and System Interrupt Map.....	27
5.2.4 Vector Table	29
5.2.5 Operation Description.....	29
5.3 System Manager.....	30
5.3.1 Overview	30
5.3.2 System Reset	30
5.3.3 System Power Distribution	31
5.4 Clock Controller	32
5.4.1 Overview	32
5.4.2 Clock Generator	34
5.4.3 System Clock and SysTick Clock.....	35
5.4.4 Peripherals Clock	36
5.4.5 Power-down Mode Clock.....	36
5.4.6 Frequency Divider Output.....	36
5.5 FLASH MEMORY CONTROLLER (FMC)	38
5.5.1 Overview	38



5.5.2	Features	38
5.6	USB Device Controller (USB)	39
5.6.1	Overview	39
5.6.2	Features	39
5.7	General Purpose I/O (GPIO)	40
5.7.1	Overview	40
5.7.2	Features	40
5.8	I ² C Serial Interface Controller (Master/Slave) (I ² C)	41
5.8.1	Overview	41
5.8.2	Features	41
5.9	PWM Generator and Capture Timer (PWM)	43
5.9.1	Overview	43
5.9.2	Features	44
5.10	Serial Peripheral Interface (SPI)	45
5.10.1	Overview	45
5.10.2	Features	45
5.11	Timer Controller (TMR)	46
5.11.1	Overview	46
5.11.2	Features	46
5.12	Watchdog Timer (WDT)	47
5.12.1	Overview	47
5.12.2	Features	47
5.13	Window Watchdog Timer (WWDT)	48
5.13.1	Overview	48
5.13.2	Features	48
5.14	UART Interface Controller (UART)	49
5.14.1	Overview	49
5.14.2	Features	50
5.15	PS/2 Device Controller (PS2D)	52
5.15.1	Overview	52
5.15.2	Features	52
5.16	I ² S Controller (I ² S)	53
5.16.1	Overview	53
5.16.2	Features	53
5.17	Analog-to-Digital Converter (ADC)	54
5.17.1	Overview	54
5.17.2	Features	54
5.18	PDMA Controller (PDMA)	55
5.18.1	Overview	55
5.18.2	Features	55
6	ARM® CORTEX™-M0 CORE	56



6.1	Overview	56
6.2	Features	56
6.3	System Timer (SysTick)	58
7	ELECTRICAL CHARACTERISTICS	59
7.1	Absolute Maximum Ratings	59
7.2	DC Electrical Characteristics	60
	7.2.1 NuMicro™ NUC123 DC Electrical Characteristics	60
7.3	AC Electrical Characteristics	65
	7.3.1 External 4~24 MHz High Speed Oscillator	65
	7.3.2 External 4~24 MHz High Speed Crystal	65
	7.3.3 Internal 22.1184 MHz High Speed Oscillator	66
	7.3.4 Internal 10 kHz Low Speed Oscillator	66
7.4	Analog Characteristics	67
	7.4.1 10-bit SARADC Specifications	67
	7.4.2 LDO and Power Management Specifications	68
	7.4.3 Low Voltage Reset Specifications	68
	7.4.4 Brown-out Detector Specifications	69
	7.4.5 Power-On Reset (5V) Specifications	69
	7.4.6 USB PHY Specifications	70
7.5	SPI Dynamic Characteristics	71
8	PACKAGE DIMENSIONS	73
8.1	64L LQFP (7x7x1.4 mm footprint 2.0 mm)	73
8.2	48L LQFP (7x7x1.4 mm footprint 2.0 mm)	74
8.3	33L QFN (5x5x0.8 mm)	75
9	REVISION HISTORY	76



List of Figures

Figure 3-1 NuMicro™ NUC123 Series Selection Code	12
Figure 3-2 NuMicro™ NUC123SxxANx LQFP 64-pin Assignment	13
Figure 3-3 NuMicro™ NUC123LxxANx LQFP 48-pin Assignment.....	14
Figure 3-4 NuMicro™ NUC123ZxxANx QFN 33-pin Assignment	15
Figure 4-1 NuMicro™ NUC123 Block Diagram	22
Figure 5-1 NuMicro™ NUC123 Power Distribution Diagram.....	31
Figure 5-2 Clock Generator Global View Diagram.....	33
Figure 5-3 Clock Generator Block Diagram	34
Figure 5-4 System Clock Block Diagram	35
Figure 5-5 SysTick Clock Control Block Diagram	35
Figure 5-6 Clock Source of Frequency Divider	36
Figure 5-7 Block Diagram of Frequency Divider	37
Figure 5-8 I ² C Bus Timing	41
Figure 6-1 Functional Controller Diagram	56
Figure 7-1 Typical Crystal Application Circuit	65
Figure 7-2 SPI Master Dynamic Characteristics Timing	71
Figure 7-3 SPI Slave Dynamic Characteristics Timing	72



List of Tables

Table 1-1 Connectivity Support Table.....	7
Table 5-1 Address Space Assignments for On-Chip Controllers.....	25
Table 5-2 Exception Model	27
Table 5-3 System Interrupt Map.....	28
Table 5-4 Vector Table Format	29
Table 5-5 UART Baud Rate Equation.....	49
Table 5-6 UART Baud Rate Setting Table	50



1 GENERAL DESCRIPTION

The NuMicro™ NUC123 series 32-bit microcontrollers are embedded with Cortex™-M0 core running up to 72 MHz, up to 36K/68K-byte embedded flash, 12K/20K-byte embedded SRAM, and 4K-byte loader ROM for the ISP. It also integrates Timers, Watchdog Timer, Windowed Watchdog Timer, PDMA with CRC calculation unit, UART, SPI/MICROWIRE, I²C, I²S, PWM Timer, GPIO, PS/2, USB 2.0 FS Device, 10-bit ADC, Low Voltage Reset Controller and Brown-out Detector.

Product Line	UART	SPI	I ² C	USB	LIN	CAN	PS/2	I ² S
NUC123	•	•	•	•	-	-	•	•

Table 1-1 Connectivity Support Table



2 FEATURES

2.1 NuMicro™ NUC123 Features

- Core
 - ARM® Cortex™-M0 core runs up to 72 MHz
 - One 24-bit system timer
 - Supports low power sleep mode
 - Single-cycle 32-bit hardware multiplier
 - NVIC for the 32 interrupt inputs, each with 4-levels of priority
 - Supports Serial Wire Debug with 2 watchpoints/4 breakpoints
- Built-in LDO for wide operating voltage ranges from 2.5 V to 5.5 V
- Flash Memory
 - 36K/68K bytes Flash for program code
 - 4KB flash for ISP loader
 - Supports In-system program (ISP) application code update
 - 512 byte page erase for flash
 - Configurable data flash address and size for both 36KB and 68KB system
 - Supports 2 wire ICP update through SWD/ICE interface
 - Supports fast parallel programming mode by external programmer
- SRAM Memory
 - 12K/20K bytes embedded SRAM
 - Supports PDMA mode
- PDMA (Peripheral DMA)
 - Supports 6 channels PDMA for automatic data transfer between SRAM and peripherals such as SPI, UART, I²S, USB 2.0 FS device, PWM and ADC
 - Supports CRC calculation with four common polynomials, CRC-CCITT, CRC-8, CRC-16 and CRC-32
- Clock Control
 - Flexible selection for different applications
 - Built-in 22.1184 MHz high speed oscillator (Trimmed to 1%) for system operation, and low power 10 kHz low speed oscillator for watchdog and wake-up operation
 - Supports one PLL, up to 144 MHz, for high performance system operation
 - External 4~24 MHz high speed crystal input for precise timing operation
- GPIO
 - Four I/O modes:
 - ◆ Quasi bi-direction
 - ◆ Push-Pull output
 - ◆ Open-Drain output
 - ◆ Input only with high impedance
 - TTL/Schmitt trigger input selectable
 - I/O pin configured as interrupt source with edge/level setting
 - Supports High Driver and High Sink IO mode



- Timer
 - Supports 4 sets of 32-bit timers with 24-bit up-timer and one 8-bit pre-scale counter
 - Independent clock source for each timer
 - Provides One-shot, Periodic, Toggle and Continuous Counting Operation modes
 - Supports event counting function
- Watchdog/Windowed-Watchdog Timer
 - Multiple clock sources
 - 8 selectable time out period from 1.6 ms ~ 26.0 sec (depending on clock source)
 - Wake-up from Power-down or Idle mode
 - Interrupt or reset selectable on watchdog timer time-out
 - Interrupt on windowed-watchdog timer time-out
 - Reset on windowed-watchdog timer time out or reload in an unexpected time window
- PWM/Capture
 - Up to two built-in 16-bit PWM generators provide four PWM outputs or two complementary paired PWM outputs
 - Each PWM generator equipped with one clock source selector, one clock divider, one 8-bit prescaler and one dead-zone generator for complementary paired PWM
 - Up to four 16-bit digital Capture timers (shared with PWM timers) providing four rising/falling capture inputs
 - Supports capture interrupt
- UART
 - Up to two UART controllers
 - UART ports with flow control (TXD, RXD, CTS and RTS)
 - UART0/1 with 16-byte FIFO for standard device
 - Supports IrDA (SIR) function
 - Supports RS-485 9-bit mode and direction control
 - Programmable baud-rate generator up to 1/16 system clock
 - Supports PDMA mode
- SPI
 - Up to three sets of SPI controller
 - Master up to 32 MHz, and Slave up to 16 MHz (chip working at 3.3V)
 - Supports SPI master/Slave mode
 - Full duplex synchronous serial data transfer
 - Variable length of transfer data from 8 to 32 bits
 - MSB or LSB first data transfer
 - Two slave/device select lines when it is selected as the master, and one slave/device select line when it is selected as the slave
 - Supports Byte Suspend mode in 16/24/32-bit transmission
 - Supports PDMA mode
- I2C
 - Up to two sets of I²C device
 - Master/Slave mode
 - Bidirectional data transfer between masters and slaves
 - Multi-master bus (no central master)
 - Arbitration between simultaneously transmitting masters without corruption of serial data on the bus
 - Serial clock synchronization allowing devices with different bit rates to communicate via one serial bus



- Serial clock synchronization used as a handshake mechanism to suspend and resume serial transfer
- Programmable clocks allow versatile rate control
- Supports multiple address recognition (four slave address with mask option)
- Supports wake-up by address recognition (for 1st slave address only)
- I2S
 - Interface with external audio CODEC
 - Operate as either master or Slave mode
 - Capable of handling 8-, 16-, 24- and 32-bit word sizes
 - Supports Mono and stereo audio data
 - Supports I²S and MSB justified data format
 - Provides two 8 word FIFO data buffers, one for transmitting and the other for receiving
 - Generates interrupt requests when buffer levels cross a programmable boundary
 - Supports two DMA requests, one for transmitting and the other for receiving
- PS/2 Device Controller
 - Host communication inhibit and request to send detection
 - Reception frame error detection
 - Programmable 1 to 16 bytes transmit buffer to reduce CPU intervention
 - Double buffer for data reception
 - S/W override bus
- USB 2.0 Full-Speed Device
 - One set of USB 2.0 FS Device 12Mbps
 - On-chip USB Transceiver
 - Provides 1 interrupt source with 4 interrupt events
 - Supports Control, Bulk In/Out, Interrupt and Isochronous transfers
 - Auto suspend function when no bus signaling for 3 ms
 - Provides 8 programmable endpoints
 - Includes 512 bytes internal SRAM as USB buffer
 - Provides remote wake-up capability
- ADC
 - 10-bit SAR ADC with 150K SPS
 - Up to 8-ch single-end input
 - Single scan/single cycle scan/continuous scan
 - Each channel with individual result register
 - Scan on enabled channels
 - Threshold voltage detection
 - Conversion start by software programming or external input
 - Supports PDMA mode
- Brown-out detector
 - With 4 levels: 4.4 V/3.7 V/2.7 V/2.2 V
 - Supports Brown-out Interrupt and Reset option
- Low Voltage Reset
 - Threshold voltage levels: 2.0 V
- One built-in LDO
- Operating Temperature: -40°C ~85°C



- Packages:
 - All Green package (RoHS)
 - LQFP 64-pin
 - LQFP 48-pin
 - QFN 33-pin



3 PARTS INFORMATION LIST AND PIN CONFIGURATION

3.1 NuMicro™ NUC123xxxANx Selection Guide

3.1.1 NuMicro™ NUC123 Selection Guide

Part number	Flash	SRAM	ISP ROM	I/O	Timer	Connectivity						I ² S	Comp.	PWM	ADC	RTC	EBI	ISP ICP IAP	Package
						UART	SPI	I ² C	USB	LIN	PS/2								
NUC123ZD4AN0	68 KB	20 KB	4 KB	Up to 20	4x32-bit	1	3	1	1	-	-	1	-	2	-	-	-	v	QFN33
NUC123ZC2AN1	36 KB	12 KB	4 KB	up to 20	4x32-bit	1	3	1	1	-	-	1	-	2	-	-	-	v	QFN33
NUC123LD4AN0	68 KB	20 KB	4 KB	up to 36	4x32-bit	2	3	2	1	-	1	1	-	4	8x10-bit	-	-	v	LQFP48
NUC123LC2AN1	36 KB	12 KB	4 KB	up to 36	4x32-bit	2	3	2	1	-	1	1	-	4	8x10-bit	-	-	v	LQFP48
NUC123SD4AN0	68 KB	20 KB	4 KB	up to 47	4x32-bit	2	3	2	1	-	1	1	-	4	8x10-bit	-	-	v	LQFP64
NUC123SC2AN1	36 KB	12 KB	4 KB	up to 47	4x32-bit	2	3	2	1	-	1	1	-	4	8x10-bit	-	-	v	LQFP64

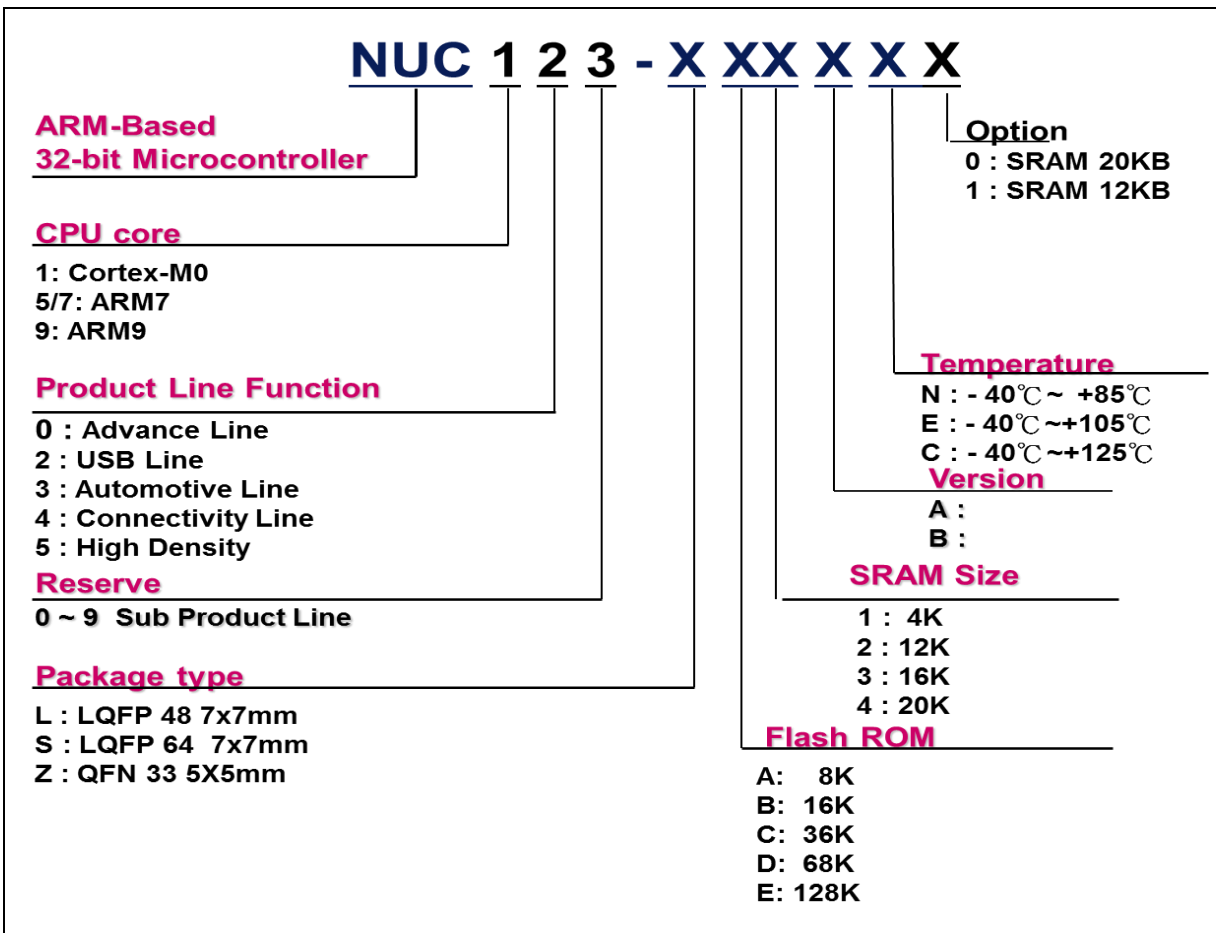

Figure 3-1 NuMicro™ NUC123 Series Selection Code



3.2 Pin Configuration

3.2.1 NuMicro™ NUC123 Pin Diagram

3.2.1.1 NuMicro™ NUC123SxxANx LQFP 64 pin

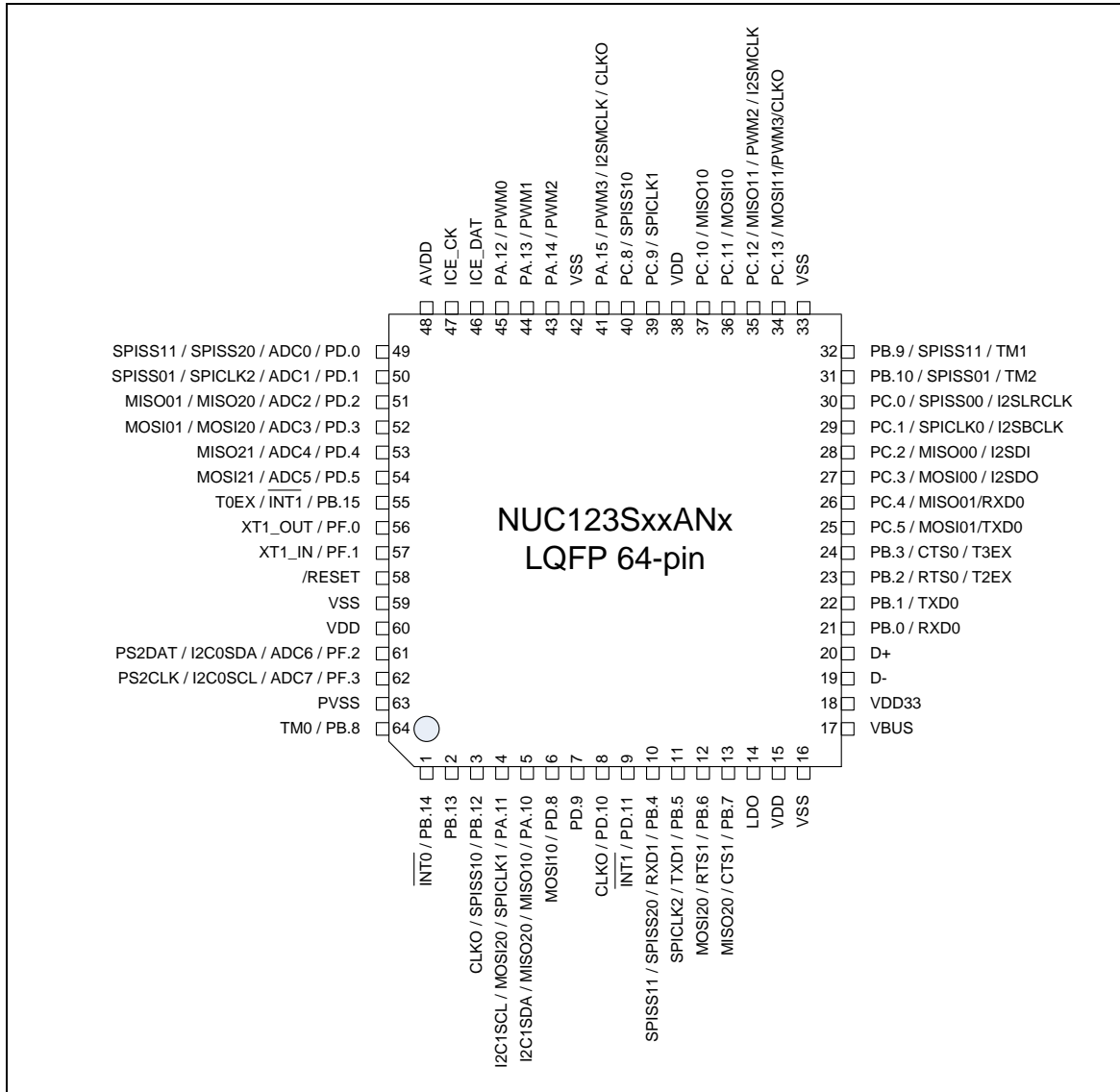

Figure 3-2 NuMicro™ NUC123SxxANx LQFP 64-pin Assignment



3.2.1.2 NuMicro™ NUC123LxxANx LQFP 48 pin

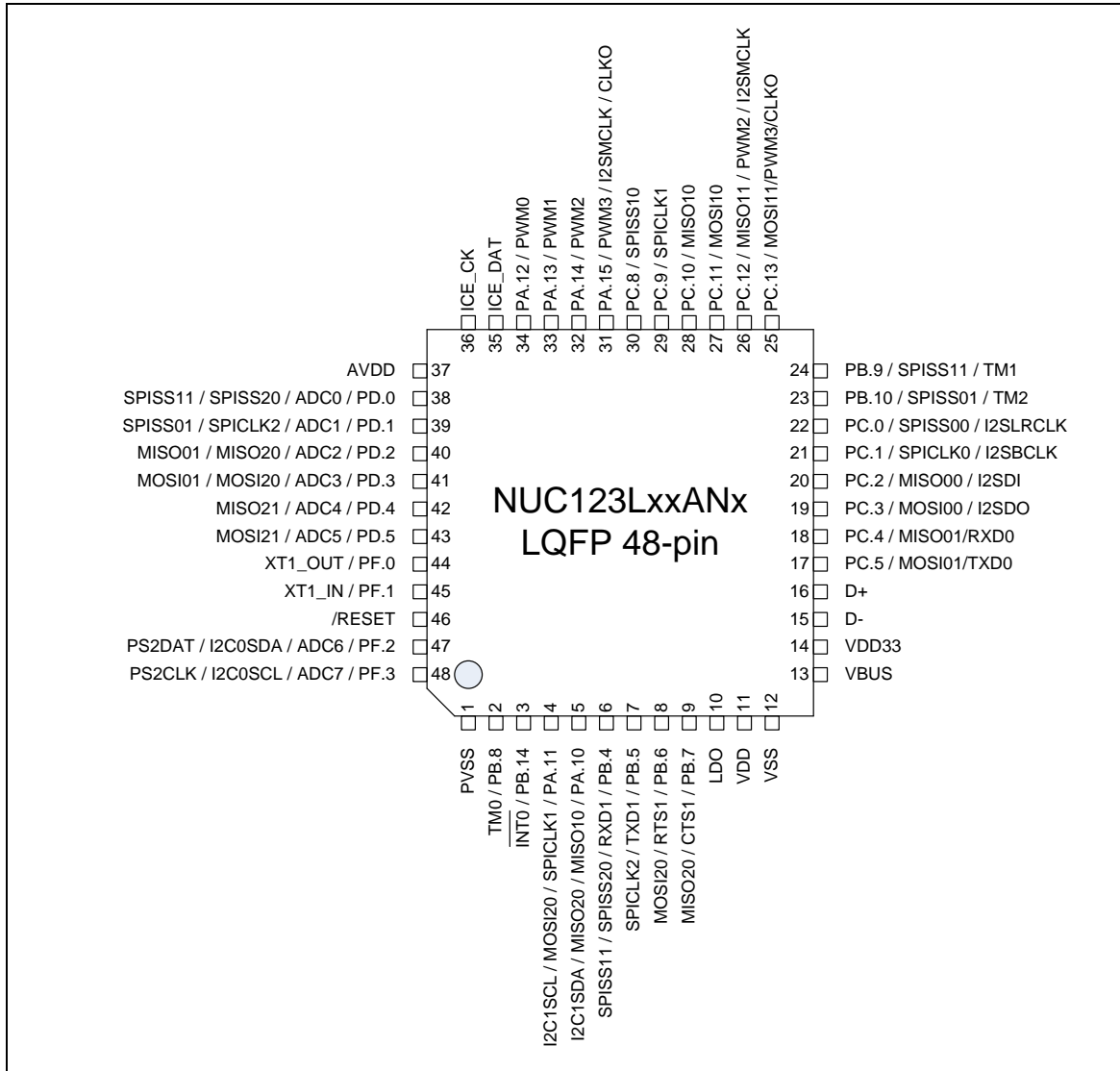

Figure 3-3 NuMicro™ NUC123LxxANx LQFP 48-pin Assignment



3.2.1.3 NuMicro™ NUC123ZxxANx QFN 33 pin

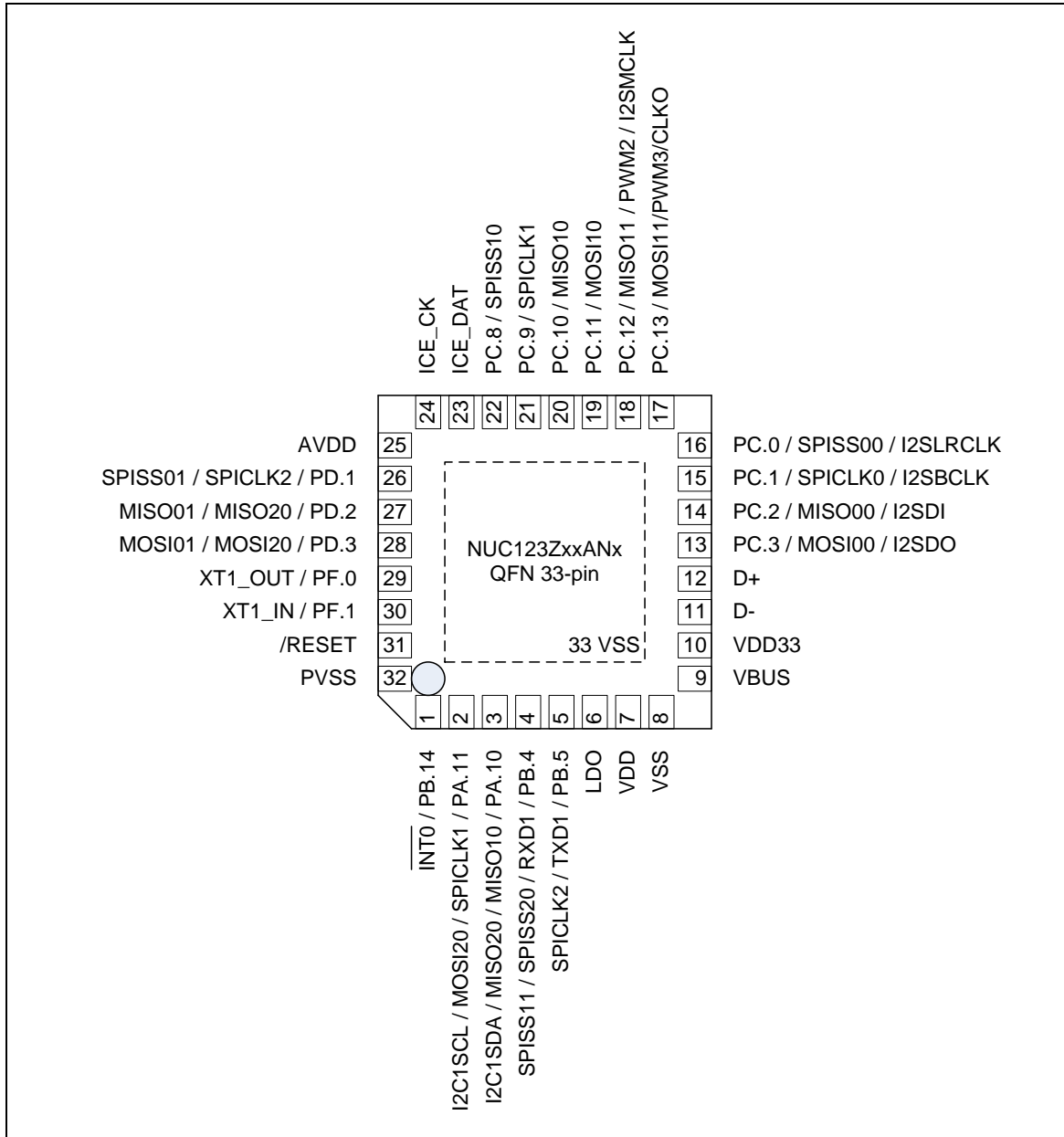

Figure 3-4 NuMicro™ NUC123ZxxANx QFN 33-pin Assignment



3.2.2 Pin Description

3.2.3 NuMicro™ NUC123 Pin Description

Pin No.			Pin Name	Type	Description
LQFP 64-pin	LQFP 48-pin	QFN 33-pin			
1	3	1	PB.14	I/O	Digital GPIO pin
			/INT0	I	External interrupt 0 input pin
2			PB.13	I/O	Digital GPIO pin
3			PB.12	I/O	Digital GPIO pin
			SPISS10	I/O	SPI1 1 st slave select pin
			CLKO	O	Frequency Divider output pin
4	4	2	PA.11	I/O	Digital GPIO pin
			SPICLK1	I/O	SPI1 serial clock pin
			MOSI20	I/O	SPI2 1 st MOSI (Master Out, Slave In) pin
			I2C1SCL	I/O	I ² C1 clock pin
5*	5*	3*	PA.10	I/O	Digital GPIO pin
			MISO10	I/O	SPI1 1 st MISO (Master In, Slave Out) pin
			MISO20	I/O	SPI2 1 st MISO (Master In, Slave Out) pin
			I2C1SDA	I/O	I ² C1 data input/output pin
6			PD.8	I/O	Digital GPIO pin
			MOSI10	I/O	SPI1 1 st MOSI (Master Out, Slave In) pin
7			PD.9	I/O	Digital GPIO pin
8			PD.10	I/O	Digital GPIO pin
			CLKO	O	Frequency Divider output pin
9			PD.11	I/O	Digital GPIO pin
			/INT1	I	External interrupt 1 input pin
10	6	4	PB.4	I/O	Digital GPIO pin
			RXD1	I	UART1 data receiver input pin
			SPISS20	I/O	SPI2 1 st slave select pin
			SPISS11	I/O	SPI1 2 nd slave select pin
11	7	5	PB.5	I/O	Digital GPIO pin



			TXD1	O	UART1 data transmitter output pin
			SPICLK2	I/O	SPI2 serial clock pin
12	8		PB.6	I/O	Digital GPIO pin
			RTS1	O	UART1 request to send output pin
			MOSI20	I/O	SPI2 1 st MOSI (Master Out, Slave In) pin
13	9		PB.7	I/O	Digital GPIO pin
			CTS1	I	UART1 clear to send input pin
			MISO20	I/O	SPI2 1 st MISO (Master In, Slave Out) pin
14	10	6	LDO	P	LDO output pin
15	11	7	VDD	P	Power supply for I/O ports and LDO source for internal PLL and digital function. Voltage range is 2.5-V ~ 5-V.
16	12	8	VSS	P	Ground
17	13	9	VBUS	USB	Power supply from USB host or hub
18	14	10	VDD33	USB	Internal power regulator output 3.3-V decoupling pin
19	15	11	D-	USB	USB differential signal D-
20	16	12	D+	USB	USB differential signal D+
21			PB.0	I/O	Digital GPIO pin
			RXD0	I	UART0 data receiver input pin
22			PB.1	I/O	Digital GPIO pin
			TXD0	O	UART0 data transmitter output pin
23			PB.2	I/O	Digital GPIO pin
			RTS0	O	UART0 request to send output pin
			T2EX	I	Timer2 external capture input pin
24			PB.3	I/O	Digital GPIO pin
			CTS0	I	UART0 clear to send input pin
			T3EX	I	Timer3 external capture input pin
25	17		PC.5	I/O	Digital GPIO pin
			MOSI01	I/O	SPI0 2 nd MOSI (Master Out, Slave In) pin
			TXD0	O	UART0 data transmitter output pin
26	18		PC.4	I/O	Digital GPIO pin
			MISO01	I/O	SPI0 2 nd MISO (Master In, Slave Out) pin



			RXD0	I	UART0 data receiver input pin
27	19	13	PC.3	I/O	Digital GPIO pin
			MOSI00	I/O	SPI0 1 st MOSI (Master Out, Slave In) pin
			I2SDO	O	I ² S data output pin
28	20	14	PC.2	I/O	Digital GPIO pin
			MISO00	I/O	SPI0 1 st MISO (Master In, Slave Out) pin
			I2SDI	I	I ² S data input pin
29	21	15	PC.1	I/O	Digital GPIO pin
			SPICLK0	I/O	SPI0 serial clock pin
			I2SBCLK	I/O	I ² S bit clock pin
30	22	16	PC.0	I/O	Digital GPIO pin
			SPISS00	I/O	SPI0 1 st slave select pin
			I2SLRCLK	I/O	I ² S left/right channel clock pin
31	23		PB.10	I/O	Digital GPIO pin
			SPISS01	I/O	SPI0 2 nd slave select pin
			TM2	I/O	Timer2 event counter input / toggle output pin
32	24		PB.9	I/O	Digital GPIO pin
			SPISS11	I/O	SPI1 2 nd slave select pin
			TM1	I/O	Timer1 event counter input / toggle output pin
33			VSS	P	Ground
34	25	17	PC.13	I/O	Digital GPIO pin
			MOSI11	I/O	SPI1 2 nd MOSI (Master Out, Slave In) pin
			PWM3	I/O	PWM3 PWM output / capture input pin
			CLKO	O	Frequency Divider output pin
35	26	18	PC.12	I/O	Digital GPIO pin
			MISO11	I/O	SPI1 2 nd MISO (Master In, Slave Out) pin
			PWM2	I/O	PWM2 PWM output / capture input pin
			I2SMCLK	O	I ² S master clock output pin
36	27	19	PC.11	I/O	Digital GPIO pin
			MOSI10	I/O	SPI1 1 st MOSI (Master Out, Slave In) pin
37	28	20	PC.10	I/O	Digital GPIO pin



			MISO10	I/O	SPI1 1 st MISO (Master In, Slave Out) pin
38			VDD	P	Power supply for I/O ports and LDO source for internal PLL and digital function. Voltage range is 2.5-V ~ 5-V.
39	29	21	PC.9	I/O	Digital GPIO pin
			SPICLK1	I/O	SPI1 serial clock pin
40	30	22	PC.8	I/O	Digital GPIO pin
			SPISS10	I/O	SPI1 1 st slave select pin
41	31		PA.15	I/O	Digital GPIO pin
			PWM3	I/O	PWM3 PWM output / capture input pin
			I2SMCLK	O	I ² S master clock output pin
			CLKO	O	Frequency Divider output pin
42			VSS	P	Ground
43	32		PA.14	I/O	Digital GPIO pin
			PWM2	I/O	PWM2 PWM output / capture input pin
44	33		PA.13	I/O	Digital GPIO pin
			PWM1	I/O	PWM1 PWM output / capture input pin
45	34		PA.12	I/O	Digital GPIO pin
			PWM0	I/O	PWM0 PWM output / capture input pin
46	35	23	ICE_DAT	I/O	Serial wired debugger data pin
47	36	24	ICE_CK	I	Serial wired debugger clock input pin
48	37		AVDD	AP	Power supply for internal analog circuit
49	38	25	PD.0	I/O	Digital GPIO pin
			ADC0	AI	ADC channel 0 analog input pin
			SPISS20	I/O	SPI2 1 st slave select pin
			SPISS11	I/O	SPI1 2 nd slave select pin
50	39	26	PD.1	I/O	Digital GPIO pin
			ADC1	AI	ADC channel 1 analog input pin
			SPICLK2	I/O	SPI2 serial clock pin
			SPISS01	I/O	SPI0 2 nd slave select pin
51	40	27	PD.2	I/O	Digital GPIO pin
			ADC2	AI	ADC channel 2 analog input pin



			MISO20	I/O	SPI2 1 st MISO (Master In, Slave Out) pin
			MISO01	I/O	SPIO 2 nd MISO (Master In, Slave Out) pin
52	41	28	PD.3	I/O	Digital GPIO pin
			ADC3	AI	ADC channel 3 analog input pin
			MOSI20	I/O	SPI2 1 st MOSI (Master Out, Slave In) pin
			MOSI01	I/O	SPIO 2 nd MOSI (Master Out, Slave In) pin
53	42		PD.4	I/O	Digital GPIO pin
			ADC4	AI	ADC channel 4 analog input pin
			MISO21	I/O	SPI2 2 nd MISO (Master In, Slave Out) pin
54	43		PD.5	I/O	Digital GPIO pin
			ADC5	AI	ADC channel 5 analog input pin
			MOSI21	I/O	SPI2 2 nd MOSI (Master Out, Slave In) pin
55			PB.15	I/O	Digital GPIO pin
			/INT1	I	External interrupt 1 input pin
			T0EX	I	Timer0 external capture input pin
56	44	29	PF.0	I/O	Digital GPIO pin
				XT1_OUT	O
57	45	30	PF.1	I/O	Digital GPIO pin
				XT1_IN	I
58	46	31	/RESET	I	External reset input: Low active, set this pin low reset chip to initial state. With internal pull-up.
59			VSS	P	Ground
60			VDD	P	Power supply for I/O ports and LDO source for internal PLL and digital circuit. Voltage range is 2.5 V ~ 5-V.
61	47		PF.2	I/O	Digital GPIO pin
			ADC6	AI	ADC channel 6 analog input pin
			I2C0SDA	I/O	I ² C0 data input/output pin
			PS2DAT	I/O	PS/2 data pin
62	48		PF.3	I/O	Digital GPIO pin
			ADC7	AI	ADC channel 7 analog input pin
			I2C0SDA	I/O	I ² C0 clock pin
			PS2CLK	I/O	PS/2 clock pin



63	1	32	PVSS	P	PLL ground
64	2		PB.8	I/O	Digital GPIO pin
			TM0	I/O	Timer2 event counter input / toggle output pin

Note: Pin Type I=Digital Input, O=Digital Output; AI=Analog Input; P=Power Pin; AP=Analog Power



4 BLOCK DIAGRAM

4.1 NuMicro™ NUC123 Block Diagram

4.1.1 NuMicro™ NUC123 Block Diagram

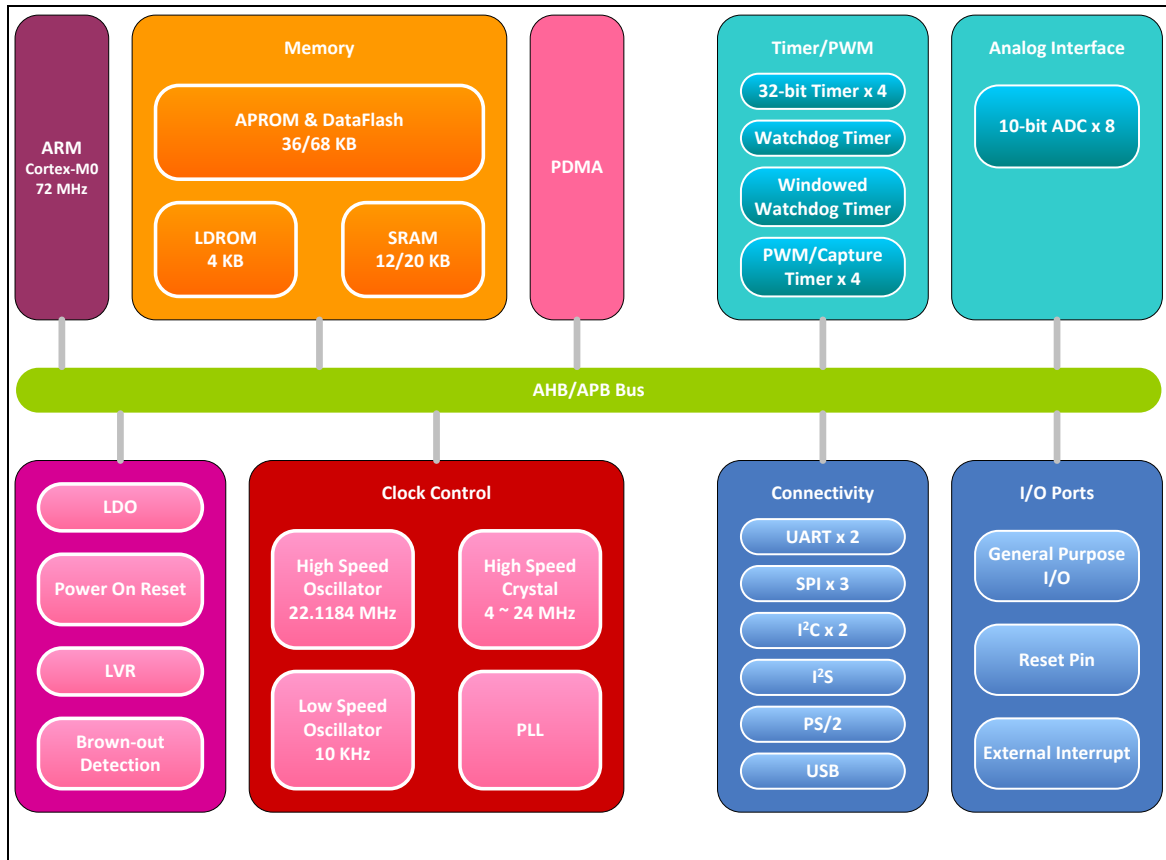

Figure 4-1 NuMicro™ NUC123 Block Diagram



5 FUNCTIONAL DESCRIPTION

5.1 Memory Organization

5.1.1 Overview

The NuMicro™ NUC123 series provides 4G-byte addressing space. The memory locations assigned to each on-chip controllers are shown in the following table. The detailed register definition, memory space, and programming detailed will be described in the following sections for each on-chip peripherals. The NuMicro™ NUC123 Series only supports little-endian data format.



5.1.2 System Memory Map

Address Space	Token	Controllers
Flash and SRAM Memory Space		
0x0000_0000 – 0x0000_FFFF	FLASH_BA	FLASH Memory Space (64KB)
0x2000_0000 – 0x2000_4FFF	SRAM_BA	SRAM Memory Space (20KB)
AHB Controllers Space (0x5000_0000 – 0x501F_FFFF)		
0x5000_0000 – 0x5000_01FF	GCR_BA	System Global Control Registers
0x5000_0200 – 0x5000_02FF	CLK_BA	Clock Control Registers
0x5000_0300 – 0x5000_03FF	INT_BA	Interrupt Multiplexer Control Registers
0x5000_4000 – 0x5000_7FFF	GPIO_BA	GPIO Control Registers
0x5000_8000 – 0x5000_BFFF	PDMA_BA	Peripheral DMA Control Registers
0x5000_C000 – 0x5000_FFFF	FMC_BA	Flash Memory Control Registers
APB1 Controllers Space (0x4000_0000 ~ 0x400F_FFFF)		
0x4000_4000 – 0x4000_7FFF	WDT_BA	Watchdog/Window Watchdog Timer Control Registers
0x4001_0000 – 0x4001_3FFF	TMR01_BA	Timer0/Timer1 Control Registers
0x4002_0000 – 0x4002_3FFF	I2C0_BA	I ² C0 Interface Control Registers
0x4003_0000 – 0x4003_3FFF	SPI0_BA	SPI0 with master/slave function Control Registers
0x4003_4000 – 0x4003_7FFF	SPI1_BA	SPI1 with master/slave function Control Registers
0x4004_0000 – 0x4004_3FFF	PWMA_BA	PWM0/1/2/3 Control Registers
0x4005_0000 – 0x4005_3FFF	UART0_BA	UART0 Control Registers
0x4006_0000 – 0x4006_3FFF	USBD_BA	USB 2.0 FS device Controller Registers
0x400E_0000 – 0x400E_FFFF	ADC_BA	Analog-Digital-Converter (ADC) Control Registers
APB2 Controllers Space (0x4010_0000 ~ 0x401F_FFFF)		
0x4010_0000 – 0x4010_3FFF	PS2_BA	PS/2 Interface Control Registers
0x4011_0000 – 0x4011_3FFF	TMR23_BA	Timer2/Timer3 Control Registers
0x4012_0000 – 0x4012_3FFF	I2C1_BA	I ² C1 Interface Control Registers
0x4013_0000 – 0x4013_3FFF	SPI2_BA	SPI2 with master/slave function Control Registers



0x4015_0000 – 0x4015_3FFF	UART1_BA	UART1 Control Registers
0x401A_0000 – 0x401A_3FFF	I2S_BA	I ² S Interface Control Registers
System Controllers Space (0xE000_E000 ~ 0xE000_EFFF)		
0xE000_E010 – 0xE000_E0FF	SCS_BA	System Timer Control Registers
0xE000_E100 – 0xE000_ECFF	SCS_BA	External Interrupt Controller Control Registers
0xE000_ED00 – 0xE000_ED8F	SCS_BA	System Control Registers

Table 5-1 Address Space Assignments for On-Chip Controllers



5.2 Nested Vectored Interrupt Controller (NVIC)

5.2.1 Overview

Cortex-M0 provides an interrupt controller as an integral part of the exception mode, named as “Nested Vectored Interrupt Controller (NVIC)”. It is closely coupled to the processor kernel

5.2.2 Features

- Nested and Vectored interrupt support
- Automatic processor state saving and restoration
- Dynamic priority changing
- Reduced and deterministic interrupt latency

The NVIC prioritizes and handles all supported exceptions. All exceptions are handled in Handler mode. This NVIC architecture supports 32 (IRQ[31:0]) discrete interrupts with 4 levels of priority. All of the interrupts and most of the system exceptions can be configured to different priority levels. When an interrupt occurs, the NVIC will compare the priority of the new interrupt to the current running one's priority. If the priority of the new interrupt is higher than the current one, the new interrupt handler will override the current handler.

When any interrupts is accepted, the starting address of the interrupt service routine (ISR) is fetched from a vector table in memory. There is no need to determine which interrupt is accepted and branch to the starting address of the correlated ISR by software. While the starting address is fetched, NVIC will also automatically save processor state including the registers “PC, PSR, LR, R0~R3, R12” to the stack. At the end of the ISR, the NVIC will restore the mentioned registers from stack and resume the normal execution. Thus it will take less and deterministic time to process the interrupt request.

The NVIC supports “Tail Chaining” which handles back-to-back interrupts efficiently without the overhead of states saving and restoration and therefore reduces delay time in switching to pending ISR at the end of current ISR. The NVIC also supports “Late Arrival” which improves the efficiency of concurrent ISRs. When a higher priority interrupt request occurs before the current ISR starts to execute (at the stage of state saving and starting address fetching), the NVIC will give priority to the higher one without delay penalty. Thus it advances the real-time capability.

For more detailed information, please refer to the “ARM® Cortex™-M0 Technical Reference Manual” and “ARM® v6-M Architecture Reference Manual”.



5.2.3 Exception Model and System Interrupt Map

Table 5-2 lists the exception model supported by the NuMicro™ NUC123 Series. Software can set four levels of priority on some of these exceptions as well as on all interrupts. The highest user-configurable priority is denoted as “0” and the lowest priority is denoted as “3”. The default priority of all the user-configurable interrupts is “0”. Note that priority “0” is treated as the fourth priority on the system, after three system exceptions “Reset”, “NMI” and “Hard Fault”.

Exception Name	Vector Number	Priority
Reset	1	-3
NMI	2	-2
Hard Fault	3	-1
Reserved	4 ~ 10	Reserved
SVCAll	11	Configurable
Reserved	12 ~ 13	Reserved
PendSV	14	Configurable
SysTick	15	Configurable
Interrupt (IRQ0 ~ IRQ31)	16 ~ 47	Configurable

Table 5-2 Exception Model

Vector Number	Interrupt Number (Bit in Interrupt Registers)	Interrupt Name	Source IP	Interrupt Description
0 ~ 15	-	-	-	System exceptions
16	0	BOD_OUT	Brown-out	Brown-out low voltage detected interrupt
17	1	WDT_INT	WDT	Watchdog/Window Watchdog Timer interrupt
18	2	EINT0	GPIO	External signal interrupt from PB.14 pin
19	3	EINT1	GPIO	External signal interrupt from PB.15 or PD.11 pin
20	4	GPAB_INT	GPIO	External signal interrupt from PA[15:0]/PB[13:0]
21	5	GPCDF_INT	GPIO	External interrupt from PC[15:0]/PD[15:0]/PF[3:0]
22	6	PWMA_INT	PWM0~3	PWM0, PWM1, PWM2 and PWM3 interrupt
23	7	Reserved	Reserved	Reserved
24	8	TMR0_INT	TMR0	Timer 0 interrupt
25	9	TMR1_INT	TMR1	Timer 1 interrupt



26	10	TMR2_INT	TMR2	Timer 2 interrupt
27	11	TMR3_INT	TMR3	Timer 3 interrupt
28	12	UART0_INT	UART0	UART0 interrupt
29	13	UART1_INT	UART1	UART1 interrupt
30	14	SPI0_INT	SPI0	SPI0 interrupt
31	15	SPI1_INT	SPI1	SPI1 interrupt
32	16	SPI2_INT	SPI2	SPI2 interrupt
33	17	Reserved	Reserved	Reserved
34	18	I2C0_INT	I ² C0	I ² C0 interrupt
35	19	I2C1_INT	I ² C1	I ² C1 interrupt
36	20	Reserved	Reserved	Reserved
37	21	Reserved	Reserved	Reserved
38	22	Reserved	Reserved	Reserved
39	23	USB_INT	USBD	USB 2.0 FS Device interrupt
40	24	PS2_INT	PS/2	PS/2 interrupt
41	25	Reserved	Reserved	Reserved
42	26	PDMA_INT	PDMA	PDMA interrupt
43	27	I2S_INT	I ² S	I ² S interrupt
44	28	PWRWU_INT	CLKC	Clock controller interrupt for chip wake-up from Power-down state
45	29	ADC_INT	ADC	ADC interrupt
46	30	Reserved	Reserved	Reserved
47	31	Reserved	Reserved	Reserved

Table 5-3 System Interrupt Map



5.2.4 Vector Table

When any interrupt is accepted, the processor will automatically fetch the starting address of the interrupt service routine (ISR) from a vector table in memory. For ARMv6-M, the vector table base address is fixed at 0x00000000. The vector table contains the initialization value for the stack pointer on reset, and the entry point addresses for all exception handlers. The vector number on previous page defines the order of entries in the vector table associated with exception handler entry as illustrated in previous section.

Vector Table Word Offset	Description
0	SP_main – The Main stack pointer
Vector Number	Exception Entry Pointer using that Vector Number

Table 5-4 Vector Table Format

5.2.5 Operation Description

NVIC interrupts can be enabled and disabled by writing to their corresponding Interrupt Set-Enable or Interrupt Clear-Enable register bit-field. The registers use a write-1-to-enable and write-1-to-clear policy, both registers reading back the current enabled state of the corresponding interrupts. When an interrupt is disabled, interrupt assertion will cause the interrupt to become Pending; however, the interrupt will not activate. If an interrupt is Active when it is disabled, it remains in its Active state until cleared by reset or an exception return. Clearing the enable bit prevents new activations of the associated interrupt.

NVIC interrupts can be pended/un-pended using a complementary pair of registers to those used to enable/disable the interrupts, named the Set-Pending Register and Clear-Pending Register respectively. The registers use a write-1-to-enable and write-1-to-clear policy, both registers reading back the current pended state of the corresponding interrupts. The Clear-Pending Register has no effect on the execution status of an Active interrupt.

NVIC interrupts are prioritized by updating an 8-bit field within a 32-bit register (each register supporting four interrupts).

The general registers associated with the NVIC are all accessible from a block of memory in the System Control Space and will be described in next section.



5.3 System Manager

5.3.1 Overview

System management includes the following sections:

- System Resets
- System Memory Map
- System management registers for Part Number ID, chip reset and on-chip controllers reset , multi-functional pin control
- System Timer (SysTick)
- Nested Vectored Interrupt Controller (NVIC)
- System Control registers

5.3.2 System Reset

The system reset can be issued by one of the below listed events. For these reset event flags can be read by RSTRC register.

- Power-On Reset
- Low level on the /RESET pin
- Watchdog Time Out Reset
- Low Voltage Reset
- Brown-out Detector Reset
- CPU Reset
- System Reset

System Reset and Power-On Reset all reset the whole chip including all peripherals. The difference between System Reset and Power-On Reset is external crystal circuit and ISPCON.BS bit. System Reset does not reset external crystal circuit and ISPCON.BS bit, but Power-On Reset does.



5.3.3 System Power Distribution

In this chip, power distribution is divided into three segments:

- Analog power from AVDD and AVSS provides the power for analog components operation.
- Digital power from VDD and VSS supplies the power to the internal regulator which provides a fixed 1.8 V power for digital operation and I/O pins.
- USB transceiver power from VBUS offers the power for operating the USB transceiver.

The outputs of internal voltage regulators, LDO and VDD33, require an external capacitor which should be located close to the corresponding pin. Analog power (AVDD) should be the same voltage level of the digital power (VDD). Figure 5-1 shows the power distribution of the NuMicro™ NUC123.

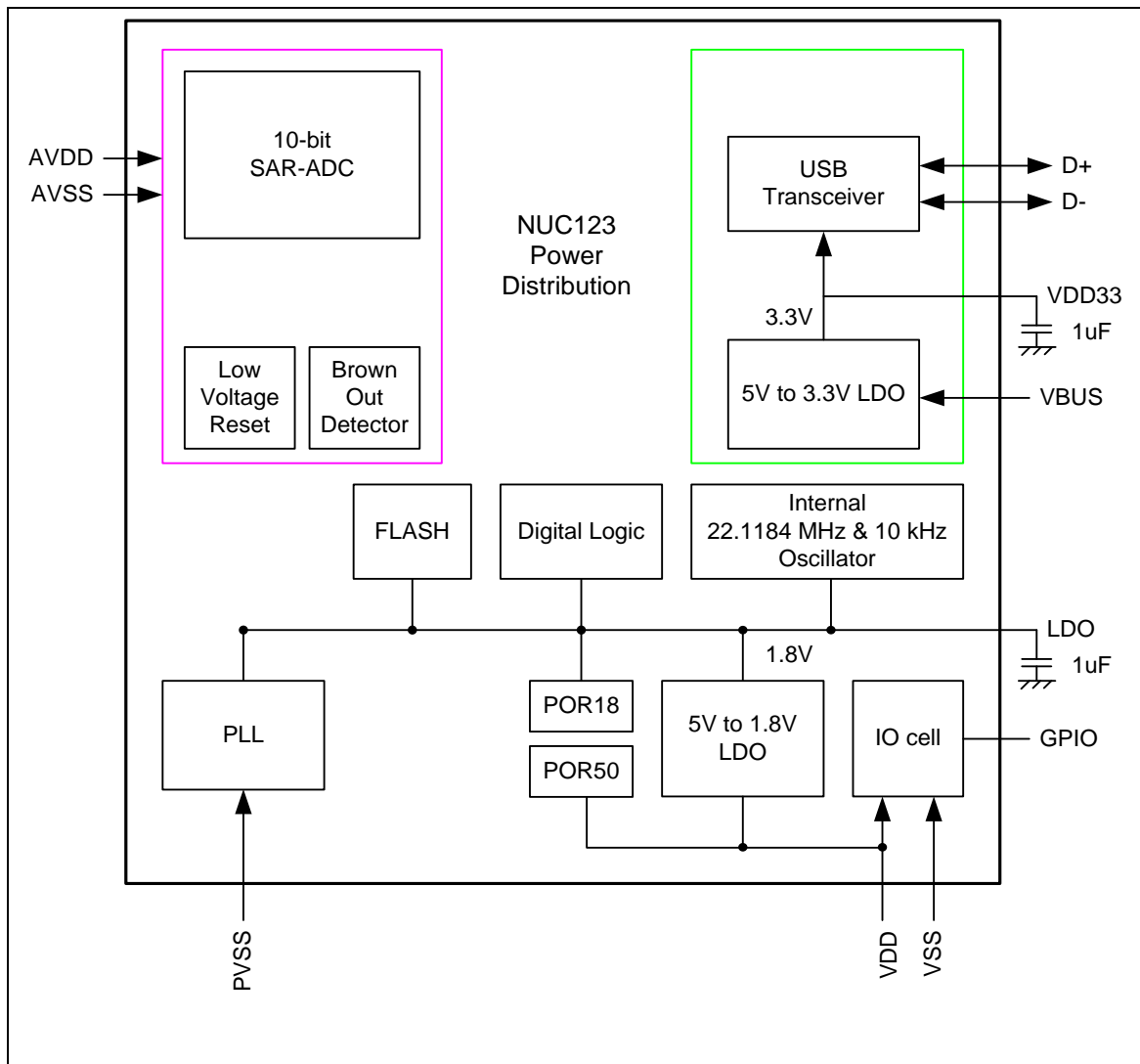

Figure 5-1 NuMicro™ NUC123 Power Distribution Diagram



5.4 Clock Controller

5.4.1 Overview

The clock controller generates the clocks for the whole chip, including system clocks and all peripheral clocks. The clock controller also implements the power control function with the individually clock ON/OFF control, clock source selection and a clock divider. The chip will not enter Power-down mode until CPU sets the Power-down enable bit (PWR_DOWN_EN) and Cortex-M0 core executes the WFI instruction. After that, chip enters Power-down mode and waits for wake-up interrupt source triggered to exit Power-down mode. In Power-down mode, the clock controller turns off the external 4~24 MHz high speed crystal (HXT) and internal 22.1184 MHz (HIRC) high speed oscillator to reduce the overall system power consumption.

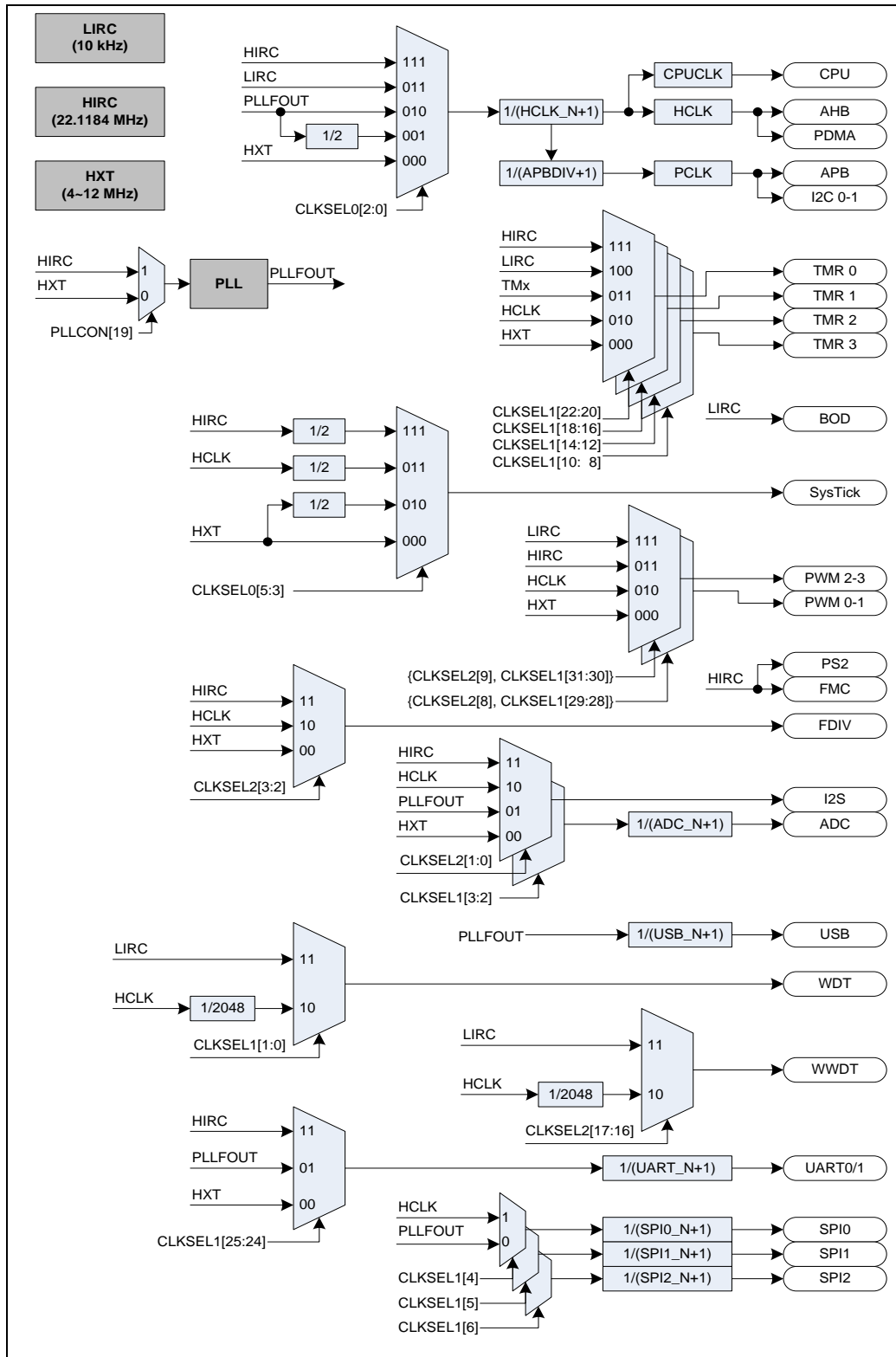

Figure 5-2 Clock Generator Global View Diagram



5.4.2 Clock Generator

The clock generator consists of 4 clock sources as listed below:

- One external 4~24 MHz high speed crystal
- One programmable PLL FOUT(PLL source consists of external 4~24 MHz high speed crystal and internal 22.1184 MHz high speed oscillator)
- One internal 22.1184 MHz high speed oscillator
- One internal 10 kHz low speed oscillator

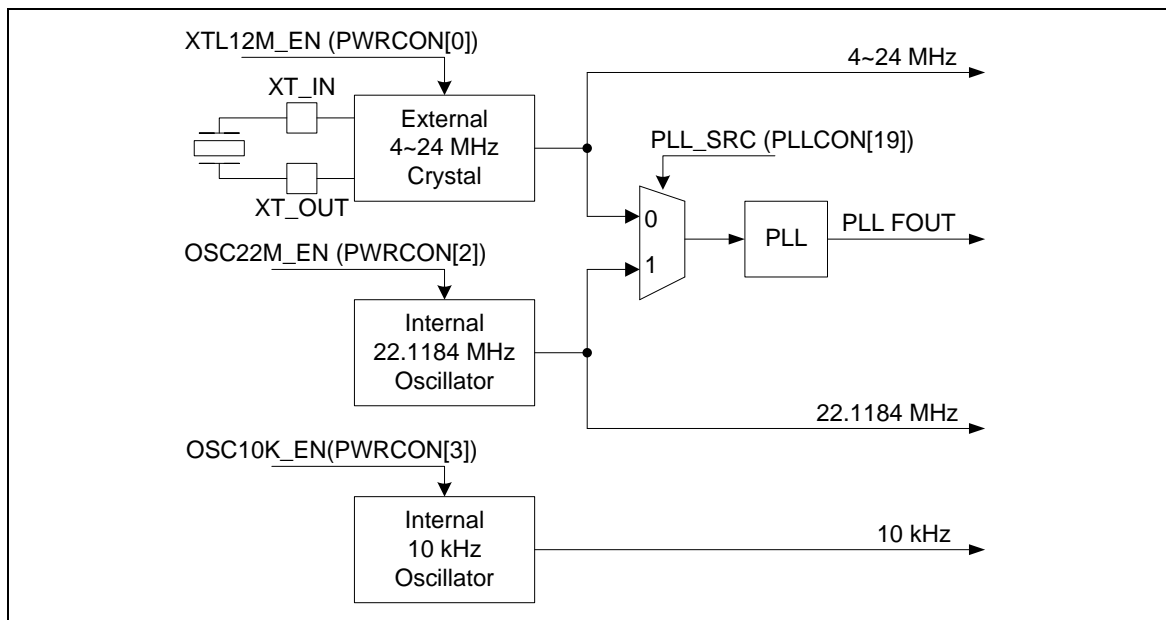

Figure 5-3 Clock Generator Block Diagram



5.4.3 System Clock and SysTick Clock

The system clock has 5 clock sources which were generated from clock generator block. The clock source switch depends on the register HCLK_S (CLKSEL0[2:0]). The block diagram is shown in Figure 5-4.

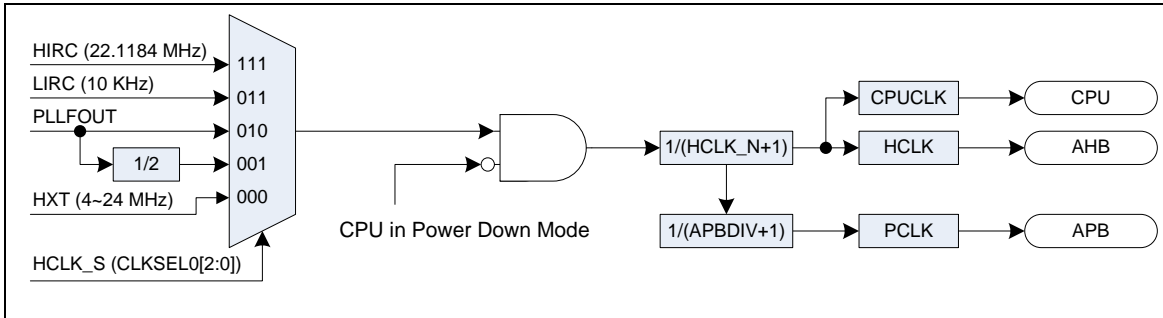

Figure 5-4 System Clock Block Diagram

The clock source of SysTick in Cortex-M0 core can use CPU clock or external clock (SYST_CSR[2]). If using external clock, the SysTick clock (STCLK) has 5 clock sources. The clock source switch depends on the setting of the register STCLK_S (CLKSEL0[5:3]). The block diagram is shown in Figure 5-5.

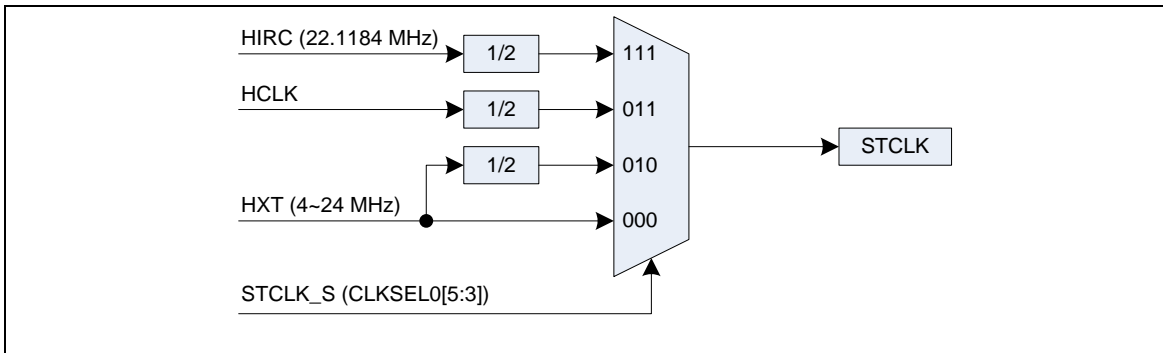

Figure 5-5 SysTick Clock Control Block Diagram

5.4.4 Peripherals Clock

The peripherals clock had different clock source switch setting depending on different peripherals. Please refer to the CLKSEL1 and CLKSEL2 register description in 5.3.8.

5.4.5 Power-down Mode Clock

When chip enters into Power-down mode, system clocks, some clock sources, and some peripheral clocks will be disabled. Some clock sources and peripherals clock are still active in Power-down mode.

The clocks kept active are listed below:

- Clock Generator
 - ◆ Internal 10 kHz low speed oscillator clock
- Peripherals Clock (When these IP adopt 10 kHz low speed oscillator as clock source)

5.4.6 Frequency Divider Output

This device is equipped with a power-of-2 frequency divider which is composed by 16 chained divide-by-2 shift registers. One of the 16 shift register outputs selected by a sixteen to one multiplexer is reflected to CLKO function pin. Therefore there are 16 options of power-of-2 divided clocks with the frequency from $F_{in}/2^1$ to $F_{in}/2^{16}$ where F_{in} is input clock frequency to the clock divider.

The output formula is $F_{out} = F_{in}/2^{(N+1)}$, where F_{in} is the input clock frequency, F_{out} is the clock divider output frequency and N is the 4-bit value in FSEL (FRQDIV[3:0]).

When write 1 to DIVIDER_EN (FRQDIV[4]), the chained counter starts to count. When write 0 to DIVIDER_EN (FRQDIV[4]), the chained counter continuously runs till divided clock reaches low state and stay in low state.

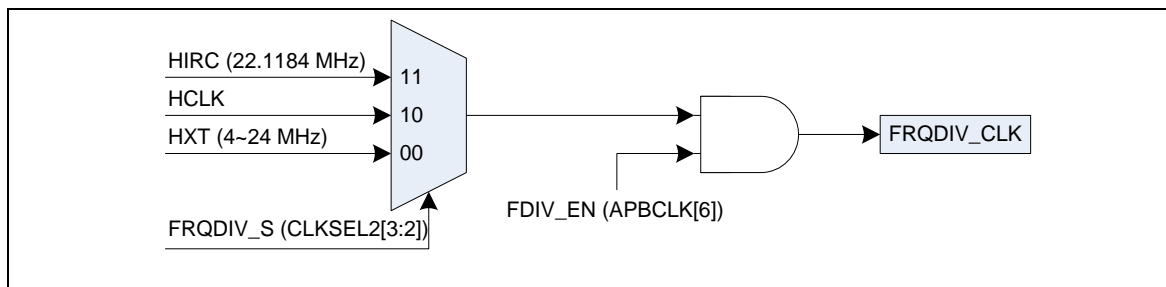

Figure 5-6 Clock Source of Frequency Divider

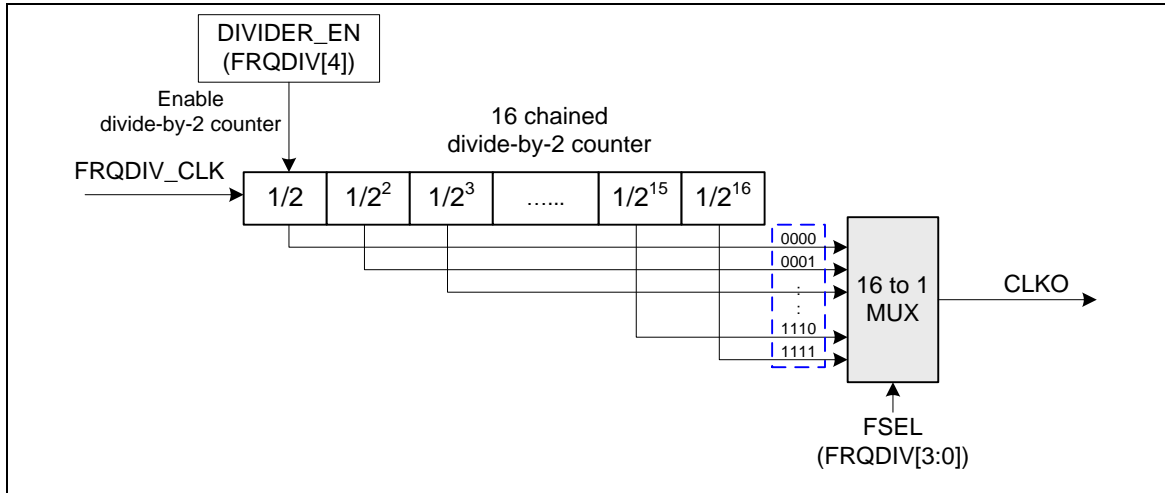

Figure 5-7 Block Diagram of Frequency Divider



5.5 FLASH MEMORY CONTROLLER (FMC)

5.5.1 Overview

The NuMicro™ NUC123 is equipped with 68/36 K bytes on-chip embedded flash for application program memory (APROM) and data flash that can be updated through ISP procedure. In System Programming (ISP) function enables user to update chip embedded flash when chip is soldered on PCB. After chip is powered on, Cortex-M0 CPU fetches code from APROM or LDROM decided by boot select (CBS) in Config0. By the way, NuMicro™ NUC123 also provides data flash for user, to store some application dependent data before chip power off.

The NuMicro™ NUC123 supports another flexible feature: configurable data flash size. The data flash size is decided by data flash variable size enable (DFVSEN), data flash enable (DFEN) in Config0 and data flash base address (DFBADR) in Config1. When DFVSEN is set to 1, the data flash size is fixed at 4K and the address is started from 0x0001_f000, and the APROM size is become 64/32K. When DFVSEN is set to 0 and DFEN is set to 1, the data flash size is zero and the APROM size is 68/36K bytes.. When DFVSEN is set to 0 and DFEN is set to 0, the APROM and data flash share 68/36K bytes continuous address and the start address of data flash is defined by (DFBADR) in Config1.

5.5.2 Features

- Runs up to 72 MHz and optional up to 50 MHz with zero wait state for continuous address read access
- 68/36 K bytes application program memory (APROM) and data flash
- 4KB in system programming (ISP) loader program memory (LDROM)
- Configurable Data flash size with 512 bytes page erase unit
- In System Program (ISP) to update on chip Flash



5.6 USB Device Controller (USB)

5.6.1 Overview

There is one set of USB 2.0 full-speed device controller and transceiver in this device. It is compliant with USB 2.0 full-speed device specification and supports control/bulk/interrupt/isochronous transfer types.

In this device controller, there are two main interfaces: APB bus and USB bus which comes from the USB PHY transceiver. For the APB bus, the CPU can program control registers through it. There are 512 bytes internal SRAM as data buffer in this controller. For IN or OUT transfer, it is necessary to write data to SRAM or read data from SRAM through the APB interface or SIE. User needs to set the effective starting address of SRAM for each endpoint buffer through "buffer segmentation register (BUFSEGx)".

There are 8 endpoints in this controller. Each of the endpoint can be configured as IN or OUT endpoint. All the operations including Control, Bulk, Interrupt and Isochronous transfer are implemented in this block. The block of ENDPOINT CONTROL is also used to manage the data sequential synchronization, endpoint states, current start address, transaction status, and data buffer status for each endpoint.

There are four different interrupt events in this controller. They are the wake-up function, device plug-in or plug-out event, USB events, such as IN ACK, OUT ACK, and BUS events, such as suspend and resume, etc. Any event will cause an interrupt, and user just needs to check the related event flags in interrupt event status register (USB_INTSTS) to acknowledge what kind of interrupt occurring, and then check the related USB Endpoint Status Register (USB_EPSTS) to acknowledge what kind of event occurring in this endpoint.

A software-disable function is also supported for this USB controller. It is used to simulate the disconnection of this device from the host. If user enables DRVSE0 bit (USB_DRVSE0), the USB controller will force the output of USB_DP and USB_DM to level low and its function is disabled. After disable the DRVSE0 bit, host will enumerate the USB device again.

Also refer to *Universal Serial Bus Specification Revision 1.1*.

5.6.2 Features

This Universal Serial Bus (USB) performs a serial interface with a single connector type for attaching all USB peripherals to the host system. Following is the feature listing of this USB.

- Compliant with USB 2.0 Full-Speed specification
- Provides 1 interrupt vector with 4 different interrupt events (WAKEUP, FLDET, USB and BUS)
- Supports Control/Bulk/Interrupt/Isochronous transfer type
- Supports suspend function when no bus activity existing for 3 ms
- Provides 8 endpoints for configurable Control/Bulk/Interrupt/Isochronous transfer types and maximum 512 bytes buffer size
- Provides remote wake-up capability



5.7 General Purpose I/O (GPIO)

5.7.1 Overview

The NuMicro™ NUC123 series has up to 47 General Purpose I/O pins shared with other function pins depending on the chip configuration. These 47 pins are arranged in 5 ports named GPIOA, GPIOB, GPIOC, GPIOD and GPIOF. GPIOA has 6 pins on PA[15:10]. GPIOB has 15 pins on PB[15:12] and PB[10:0]. GPIOC has 12 pins on PC[13:8] and PC[5:0]. GPIOD has 10 pins on PD[11:8] and PD[5:0]. GPIOF has 4 pins on PF[3:0]. Each one of the 47 pins is independent and has the corresponding register bits to control the pin mode function and data.

The I/O type of each of I/O pins can be configured by software individually as input, output, open-drain or quasi-bidirectional mode. After reset, the I/O type of all pins stay in quasi-bidirectional mode and port data register GPIOx_DOUT[15:0] resets to 0x0000_FFFF. Each I/O pin has a very weakly individual pull-up resistor which is about 110 K Ω ~300 K Ω for V_{DD} is from 5.0 V to 2.5 V.

5.7.2 Features

- Four I/O modes:
 - ◆ Quasi bi-direction
 - ◆ Push-Pull output
 - ◆ Open-Drain output
 - ◆ Input only with high impedance
- TTL/Schmitt trigger input selectable
- I/O pin can be configured as interrupt source with edge/level setting
- Supports High Driver and High Sink IO mode



5.8 I²C Serial Interface Controller (Master/Slave) (I²C)

5.8.1 Overview

I²C is a two-wire, bi-directional serial bus that provides a simple and efficient method of data exchange between devices. The I²C standard is a true multi-master bus including collision detection and arbitration that prevents data corruption if two or more masters attempt to control the bus simultaneously.

Data is transferred between a Master and a Slave synchronously to SCL on the SDA line on a byte-by-byte basis. Each data byte is 8-bit long. There is one SCL clock pulse for each data bit with the MSB being transmitted first. An acknowledge bit follows each transferred byte. Each bit is sampled during the high period of SCL; therefore, the SDA line may be changed only during the low period of SCL and must be held stable during the high period of SCL. A transition on the SDA line while SCL is high is interpreted as a command (START or STOP). Please refer to the Figure 5-8 for more detail I²C BUS Timing.

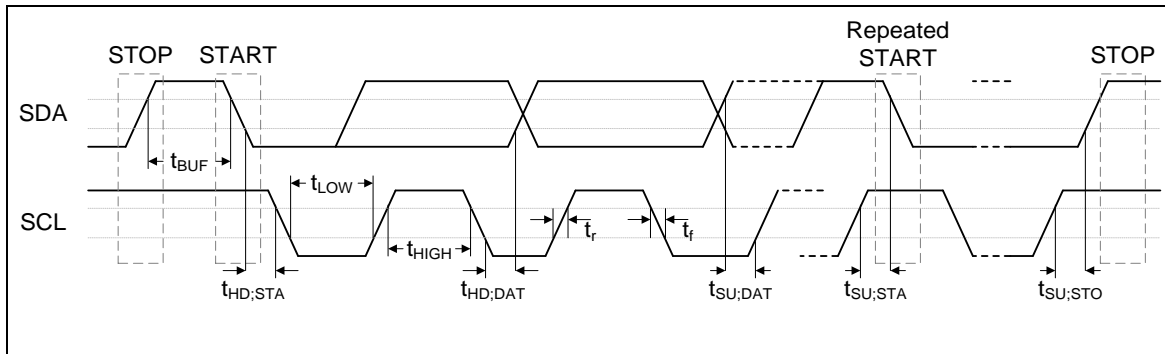

Figure 5-8 I²C Bus Timing

The device's on-chip I²C logic provides the serial interface that meets the I²C bus standard mode specification. The I²C port handles byte transfers autonomously. To enable this port, the bit ENS1 in I2CON should be set to '1'. The I²C H/W interfaces to the I²C bus via two pins: SDA and SCL. Pull up resistor is needed for I²C operation as these are open drain pins. When the I/O pins are used as I²C port, user must set the pins function to I²C in advance.

5.8.2 Features

The I²C bus uses two wires (SDA and SCL) to transfer information between devices connected to the bus. The main features of the bus are:

- Master/Slave mode
- Bidirectional data transfer between masters and slaves
- Multi-master bus (no central master)
- Arbitration between simultaneously transmitting masters without corruption of serial data on the bus
- Serial clock synchronization allows devices with different bit rates to communicate via one serial bus



- Serial clock synchronization can be used as a handshake mechanism to suspend and resume serial transfer
- Built-in a 14-bit time-out counter will request the I²C interrupt if the I²C bus hangs up and timer-out counter overflows.
- External pull-up are needed for high output
- Programmable clocks allow versatile rate control
- Supports 7-bit addressing mode
- I²C-bus controllers supporting multiple address recognition (four slave address with mask option)
- Supports Power-down wake-up function



5.9 PWM Generator and Capture Timer (PWM)

5.9.1 Overview

This chip has 1 set of PWM group supporting 1 set of PWM generators which can be configured as 4 independent PWM outputs, PWM0~PWM3, or as 2 complementary PWM pairs, (PWM0, PWM1), (PWM2, PWM3) with two programmable dead-zone generators.

Each PWM generator has one 8-bit prescaler, one clock divider with 5 divided frequencies (1, 1/2, 1/4, 1/8, 1/16), two PWM Timers including two clock selectors, two 16-bit PWM down-counters for PWM period control, two 16-bit comparators for PWM duty control and one dead-zone generator. The PWM generators provide four independent PWM interrupt flags which are set by hardware when the corresponding PWM period down counter reaches zero. Each PWM interrupt source with its corresponding enable bit can cause CPU to request PWM interrupt. The PWM generators can be configured as one-shot mode to produce only one PWM cycle signal or auto-reload mode to output PWM waveform continuously.

When PCR.DZEN01 is set, PWM0 and PWM1 perform complementary PWM paired function; the paired PWM period, duty and dead-time are determined by PWM0 timer and dead-zone generator 0. Similarly, the complementary PWM pairs of (PWM2, PWM3), timers and dead-zone generator 2, respectively. Refer to **Error! Reference source not found.** to **Error! Reference source not found.** for the architecture of PWM Timers.

To prevent PWM driving output pin with unsteady waveform, the 16-bit period down counter and 16-bit comparator are implemented with double buffer. When user writes data to counter/comparator buffer registers the updated value will be load into the 16-bit down counter/comparator at the time down counter reaching zero. The double buffering feature avoids glitch at PWM outputs.

When the 16-bit period down counter reaches zero, the interrupt request is generated. If PWM-timer is set as auto-reload mode, when the down counter reaches zero, it is reloaded with PWM Counter Register (CNRx) automatically then start decreasing, repeatedly. If the PWM-timer is set as one-shot mode, the down counter will stop and generate one interrupt request when it reaches zero.

The value of PWM counter comparator is used for pulse high width modulation. The counter control logic changes the output to high level when down-counter value matches the value of compare register.

The alternate feature of the PWM-timer is digital input Capture function. If Capture function is enabled the PWM output pin is switched as capture input mode. The Capture0 and PWM0 share one timer which is included in PWM0 and the Capture1 and PWM1 share PWM1 timer, and etc. Therefore user must setup the PWM-timer before enable Capture feature. After capture feature is enabled, the capture always latched PWM-counter to Capture Rising Latch Register (CRLR) when input channel has a rising transition and latched PWM-counter to Capture Falling Latch Register (CFLR) when input channel has a falling transition. Capture channel 0 interrupt is programmable by setting CCR0.CRL_IE0[1] (Rising latch Interrupt enable) and CCR0.CFL_IE0[2] (Falling latch Interrupt enable) to decide the condition of interrupt occur. Capture channel 1 has the same feature by setting CCR0.CRL_IE1[17] and CCR0.CFL_IE1[18]. And capture channel 2 to channel 3 on each group have the same feature by setting the corresponding control bits in CCR2. For each group, whenever Capture issues Interrupt 0/1/2/3, the PWM counter 0/1/2/3 will be reload at this moment.

The maximum captured frequency that PWM can capture is confined by the capture interrupt latency. When capture interrupt occurred, software will perform at least three steps including: Read PIIR to get interrupt source and Read CRLRx/CFLRx(x=0~3) to get capture value and finally write 1 to clear PIIR to zero. If interrupt latency takes time T0 to finish, the capture signal



must not transition during this interval (T_0). In this case, the maximum capture frequency will be $1/T_0$. For example:

HCLK = 50 MHz, PWM_CLK = 25 MHz, Interrupt latency is 900 ns

Therefore, the maximum capture frequency will be $1/900\text{ns} \approx 1000$ kHz

5.9.2 Features

5.9.2.1 PWM function:

- Two PWM generators, each supporting one 8-bit prescaler, one clock divider, two PWM-timers (down counter), one dead-zone generator, and two PWM outputs
- Up to 16-bit resolution
- PWM Interrupt request synchronized with PWM period
- One-shot or Auto-reload mode PWM
- Up to 1 PWM group (PWMA) to support 4 PWM channels or 2 PWM paired channels

5.9.2.2 Capture function:

- Timing control logic shared with PWM Generators
- Supports 4 Capture input channels shared with 4 PWM output channels
- Each channel supports one rising latch register (CRLR), one falling latch register (CFLR) and Capture interrupt flag (CAPIFx)
- Supports PDMA transfer function for each channel



5.10 Serial Peripheral Interface (SPI)

5.10.1 Overview

The Serial Peripheral Interface (SPI) is a synchronous serial data communication protocol that operates in full duplex mode. Devices communicate in Master/Slave mode with the 4-wire bi-direction interface. This chip contains up to three sets of SPI controllers performing a serial-to-parallel conversion on data received from a peripheral device, and a parallel-to-serial conversion on data transmitted to a peripheral device. Each set of SPI controller can be configured as a master or a slave device.

The SPI controller supports the variable serial clock function for special applications and 2-bit Transfer mode to connect 2 off-chip slave devices at the same time. This controller also supports the PDMA function to access the data buffer and also supports Dual I/O Transfer mode.

5.10.2 Features

- Up to three sets of SPI controller
- Supports Master or Slave mode operation
- Supports 2-bit Transfer mode
- Supports Dual I/O Transfer mode
- Configurable bit length of a transfer word from 8 to 32-bit
- Provides separate 8-layer depth transmit and receive FIFO buffers
- Supports MSB first or LSB first transfer sequence
- Two slave select lines in Master mode
- Supports the byte reorder function
- Supports Byte or Word Suspend mode
- Variable output serial clock frequency in Master mode
- Supports PDMA transfer
- Supports 3-wire, no slave select signal, bi-direction interface



5.11 Timer Controller (TMR)

5.11.1 Overview

The timer controller includes four 32-bit timers, TIMER0~TIMER3, which allows user to easily implement a timer control for applications. The timer can perform functions like frequency measurement, event counting, interval measurement, clock generation, delay timing, and so on. The timer can generate an interrupt signal upon time-out, or provide the current value during operation.

5.11.2 Features

- 4 sets of 32-bit timers with 24-bit up-timer and one 8-bit pre-scale counter
- Independent clock source for each timer
- Provides One-shot, Periodic, Toggle and Continuous Counting Operation modes
- Time out period = (Period of timer clock input) * (8-bit pre-scale counter + 1) * (24-bit TCMP)
- Maximum counting cycle time = $(1 / T \text{ MHz}) * (2^8) * (2^{24})$, T is the period of timer clock
- 24-bit timer value is readable through TDR (Timer Data Register)
- Supports event counting function to count the event from external pin
- Supports input capture function to capture or reset counter value



5.12 Watchdog Timer (WDT)

5.12.1 Overview

The purpose of Watchdog Timer is to perform a system reset when system runs into an unknown state. This prevents system from hanging for an infinite period of time. Besides, this Watchdog Timer supports another function to wake-up chip from Power-down mode.

5.12.2 Features

- 18-bit free running counter to avoid chip from Watchdog timer reset before the delay time expires.
- Selectable time-out interval ($2^4 \sim 2^{18}$) and the time out interval is 104 ms ~ 26.3168 s (if WDT_CLK = 10 kHz).
- Reset period = $(1 / 10 \text{ kHz}) * 63$, if WDT_CLK = 10 kHz.



5.13 Window Watchdog Timer (WWDT)

5.13.1 Overview

The purpose of Window Watchdog Timer is to perform a system reset within a specified window period to prevent software run to uncontrollable status by any unpredictable condition.

5.13.2 Features

- 6-bit down counter and 6-bit compare value to make the window period flexible
- Selectable WWDT clock pre-scale counter to make WWDT time-out interval variable



5.14 UART Interface Controller (UART)

This chip provides up to two channels of Universal Asynchronous Receiver/Transmitters (UART). The UART controller UART0 and UART1 support flow control function.

5.14.1 Overview

The Universal Asynchronous Receiver/Transmitter (UART) performs a serial-to-parallel conversion on data received from the peripheral, and a parallel-to-serial conversion on data transmitted from the CPU. The UART controller also supports IrDA SIR Function and RS-485 mode functions. Each UART channel supports six types of interrupts including transmitter FIFO empty interrupt (INT_THRE), receiver threshold level reaching interrupt (INT_RDA), line status interrupt (parity error or framing error or break interrupt) (INT_RLS), receiver buffer time out interrupt (INT_TOUT), MODEM/Wake-up status interrupt (INT_MODEM) and Buffer error interrupt (INT_BUF_ERR). Interrupts of UART0 number is 12 (vector number is 28); Interrupt number 13 (vector number is 29) supports UART1 interrupt. Refer to Nested Vectored Interrupt Controller chapter for System Interrupt Map.

The UART0 and UART1 are built-in with a 16-byte transmitter FIFO (TX_FIFO) and a 16-byte receiver FIFO (RX_FIFO) that reduces the number of interrupts presented to the CPU. The CPU can read the status of the UART at any time during the operation. The reported status information includes the type and condition of the transfer operations being performed by the UART, as well as 4 error conditions (parity error, framing error, break interrupt and buffer error) probably occur while receiving data. The UART includes a programmable baud rate generator that is capable of dividing clock input by divisors to produce the serial clock that transmitter and receiver need. The baud rate equation is $\text{Baud Rate} = \text{UART_CLK} / M * [\text{BRD} + 2]$, where M and BRD are defined in Baud Rate Divider Register (UA_BAUD). Table 5-5 lists the equations in the various conditions and Table 5-6 lists the UART baud rate settings.

Mode	DIV_X_EN	DIV_X_ONE	Divider X	BRD	Baud Rate Equation
0	0	0	Don't care	A	$\text{UART_CLK} / [16 * (A+2)]$
1	1	0	B	A	$\text{UART_CLK} / [(B+1) * (A+2)]$, B must ≥ 8
2	1	1	Don't care	A	$\text{UART_CLK} / (A+2)$, A must ≥ 9

Table 5-5 UART Baud Rate Equation

System Clock = Internal 22.1184 MHz High Speed Oscillator						
Baud Rate	Mode 0		Mode 1		Mode 2	
	Parameter	Register	Parameter	Register	Parameter	Register
921600	x	x	A=0,B=11	0x2B00_0000	A=22	0x3000_0016
460800	A=1	0x0000_0001	A=1,B=15 A=2,B=11	0x2F00_0001 0x2B00_0002	A=46	0x3000_002E
230400	A=4	0x0000_0004	A=4,B=15 A=6,B=11	0x2F00_0004 0x2B00_0006	A=94	0x3000_005E



115200	A=10	0x0000_000A	A=10,B=15 A=14,B=11	0x2F00_000A 0x2B00_000E	A=190	0x3000_00BE
57600	A=22	0x0000_0016	A=22,B=15 A=30,B=11	0x2F00_0016 0x2B00_001E	A=382	0x3000_017E
38400	A=34	0x0000_0022	A=62,B=8 A=46,B=11 A=34,B=15	0x2800_003E 0x2B00_002E 0x2F00_0022	A=574	0x3000_023E
19200	A=70	0x0000_0046	A=126,B=8 A=94,B=11 A=70,B=15	0x2800_007E 0x2B00_005E 0x2F00_0046	A=1150	0x3000_047E
9600	A=142	0x0000_008E	A=254,B=8 A=190,B=11 A=142,B=15	0x2800_00FE 0x2B00_00BE 0x2F00_008E	A=2302	0x3000_08FE
4800	A=286	0x0000_011E	A=510,B=8 A=382,B=11 A=286,B=15	0x2800_01FE 0x2B00_017E 0x2F00_011E	A=4606	0x3000_11FE

Table 5-6 UART Baud Rate Setting Table

The UART0 and UART1 controllers support auto-flow control function that uses two low-level signals (the level can be change by configure UA_MSR and UA_MCR register), /CTS (clear-to-send) and /RTS (request-to-send), to control the flow of data transfer between the UART and external devices (ex: Modem). When auto-flow is enabled, the UART is not allowed to receive data until the UART asserts /RTS to external device. When the number of bytes in the RX FIFO is equal to the value of RTS_TRI_LEV (UA_FCR [19:16]), the /RTS is de-asserted. The UART sends data out when UART controller detects /CTS is asserted from external device. If a valid asserted /CTS is not detected the UART controller will not send data out.

The UART controllers also provides Serial IrDA (SIR, Serial Infrared) function (User must set IrDA_EN (UA_FUN_SEL [1]) to enable IrDA function). The SIR specification defines a short-range infrared asynchronous serial transmission mode with one start bit, 8 data bits, and 1 stop bit. The maximum data rate is 115.2 Kbps (half duplex). The IrDA SIR block contains an IrDA SIR Protocol encoder/decoder. The IrDA SIR protocol is half-duplex only. So it cannot transmit and receive data at the same time. The IrDA SIR physical layer specifies a minimum 10ms transfer delay between transmission and reception. This delay feature must be implemented by software.

For NuMicro™ NUC123 Series, another alternate function of UART controllers is RS-485 9-bit mode function, and direction control provided by RTS pin or can program GPIO (PB.2 for RTS0 and PB.6 for RTS1) to implement the function by software. The RS-485 mode is selected by setting the UA_FUN_SEL register to select RS-485 function. The RS-485 driver control is implemented using the RTS control signal from an asynchronous serial port to enable the RS-485 driver. In RS-485 mode, many characteristics of the RX and TX are same as UART.

5.14.2 Features

- Full duplex, asynchronous communications
- Separates receive / transmit 16 bytes entry FIFO for data payloads



- Supports hardware auto flow control/flow control function (CTS, RTS) and programmable RTS flow control trigger level.
- Programmable receiver buffer trigger level
- Supports programmable baud-rate generator for each channel individually
- Supports CTS wake-up function.
- Supports 8-bit receiver buffer time out detection function
- UART0/UART1 served by the DMA controller
- Programmable transmitting data delay time between the last stop and the next start bit by setting UA_TOR [DLY] register
- Supports break error, frame error, parity error and receive/transmit buffer overflow detect function
- Fully programmable serial-interface characteristics
 - Programmable number of data bit, 5-, 6-, 7-, 8-bit character
 - Programmable parity bit, even, odd, no parity or stick parity bit generation and detection
 - Programmable stop bit, 1, 1.5, or 2 stop bit generation
- Supports IrDA SIR function mode
 - Supports for 3-/16-bit duration for normal mode
- Supports RS-485 function mode.
 - Supports RS-485 9-bit mode
 - Supports hardware or software direct enable control provided by RTS pin



5.15 PS/2 Device Controller (PS2D)

5.15.1 Overview

PS/2 device controller provides basic timing control for PS/2 communication. All communication between the device and the host is managed through the CLK and DATA pins. Unlike PS/2 keyboard or mouse device controller, the received/transmit code needs to be translated as meaningful code by firmware. The device controller generates the CLK signal after receiving a request to send, but host has ultimate control over communication. DATA sent from the host to the device is read on the rising edge and DATA sent from device to the host is change after rising edge. A 16 bytes FIFO is used to reduce CPU intervention. S/W can select 1 to 16 bytes for a continuous transmission.

5.15.2 Features

- Host communication inhibit and request to send detection
- Reception frame error detection
- Programmable 1 to 16 bytes transmit buffer to reduce CPU intervention
- Double buffer for data reception
- S/W override bus



5.16 I²S Controller (I²S)

5.16.1 Overview

The I²S controller consists of IIS protocol to interface with external audio CODEC. Two 8 word deep FIFO for read path and write path respectively and is capable of handling 8 ~ 32 bit word sizes. DMA controller handles the data movement between FIFO and memory.

5.16.2 Features

- Operated as either master or slave
- Capable of handling 8-, 16-, 24- and 32-bit word sizes
- Supports Mono and stereo audio data
- Supports I²S and MSB justified data format
- Provides two 8 word FIFO data buffers, one for transmitting and the other for receiving
- Generates interrupt requests when buffer levels cross a programmable boundary
- Two DMA requests, one for transmitting and the other for receiving



5.17 Analog-to-Digital Converter (ADC)

5.17.1 Overview

NuMicro™ NUC123 Series contains one 10-bit successive approximation analog-to-digital converters (SAR A/D converter) with 8 input channels. The A/D converter supports three operation modes: single, single-cycle scan and continuous scan mode. The A/D converters can be started by software and external STADC pin.

5.17.2 Features

- Analog input voltage range: 0~Vref (Max to 5.0V)
- 10-bit resolution and 8-bit accuracy is guaranteed
- Up to 8 single-end analog input channels
- Maximum ADC clock frequency to 6 MHz
- Up to 150K SPS conversion rate
- Three operating modes
 - Single mode: A/D conversion is performed one time on a specified channel
 - Single-cycle Scan mode: A/D conversion is performed one cycle on all specified channels with the sequence from the lowest numbered channel to the highest numbered channel
 - Continuous Scan mode: A/D converter continuously performs Single-cycle scan mode until software stops A/D conversion
- A/D conversion started by:
 - Software write 1 to ADST bit
 - External pin STADC
 - PWM output trigger
- Conversion results held in data registers for each channel with valid and overrun indicators
- Conversion result can be compared with specify value and user can select whether to generate an interrupt when conversion result is equal to the compare register setting.
- Channel 7 supports 2 input sources: external analog voltage and internal fixed band-gap voltage



5.18 PDMA Controller (PDMA)

5.18.1 Overview

The NuMicro™ NUC123 DMA contains six-channel peripheral direct memory access (PDMA) controller and a cyclic redundancy check (CRC) generator.

The PDMA can transfers data to and from memory or transfer data to and from APB devices. For PDMA channel (PDMA CH0~CH5), there is one-word buffer as transfer buffer between the Peripherals APB devices and Memory. Software can stop the PDMA operation by disable PDMA [PDMACEN]. The CPU can recognize the completion of a PDMA operation by software polling or when it receives an internal PDMA interrupt. The PDMA controller can increase source or destination address or fixed them as well.

The DMA controller contains a cyclic redundancy check (CRC) generator that can perform CRC calculation with programmable polynomial settings. The CRC engine supports CPU PIO mode and DMA transfer mode.

5.18.2 Features

- Supports six PDMA channels and one CRC channel. Each PDMA channel can support a unidirectional transfer
- AMBA AHB master/slave interface compatible, for data transfer and register read/write
- Hardware round robin priority scheme. DMA channel 0 has the highest priority
- PDMA
 - ◇ Peripheral-to-memory, memory-to-peripheral, and memory-to-memory transfer
 - ◇ Supports word/half-word/byte transfer data width from/to peripheral
 - ◇ Supports address direction: increment, fixed
- Cyclic Redundancy Check (CRC)
 - ◇ Supports four common polynomials CRC-CCITT, CRC-8, CRC-16, and CRC-32
 - CRC-CCITT: $X^{16} + X^{12} + X^5 + 1$
 - CRC-8: $X^8 + X^2 + X + 1$
 - CRC-16: $X^{16} + X^{15} + X^2 + 1$
 - CRC-32: $X^{32} + X^{26} + X^{23} + X^{22} + X^{16} + X^{12} + X^{11} + X^{10} + X^8 + X^7 + X^5 + X^4 + X^2 + X + 1$
 - ◇ Programmable seed value
 - ◇ Supports programmable order reverse setting for input data and CRC checksum
 - ◇ Supports programmable 1's complement setting for input data and CRC checksum.
 - ◇ Supports CPU PIO mode or DMA transfer mode
 - ◇ Supports 8/16/32-bit of data width in CPU PIO mode
 - 8-bit write mode: 1-AHB clock cycle operation
 - 16-bit write mode: 2-AHB clock cycle operation
 - 32-bit write mode: 4-AHB clock cycle operation
 - ◇ Supports byte alignment transfer length in CRC DMA mode

6 ARM® CORTEX™-M0 CORE

6.1 Overview

The Cortex™-M0 processor, a configurable, multistage, 32-bit RISC processor, has an AMBA AHB-Lite interface and includes an NVIC component. The processor has optional hardware debug functionality, can execute Thumb code, and is compatible with other Cortex-M profile processors. The profile supports two modes -Thread mode and Handler mode. Handler mode is entered as a result of an exception. An exception return can only be issued in Handler mode. Thread mode is entered on Reset, and can be entered as a result of an exception return. Figure 6-1 shows the functional controller of processor.

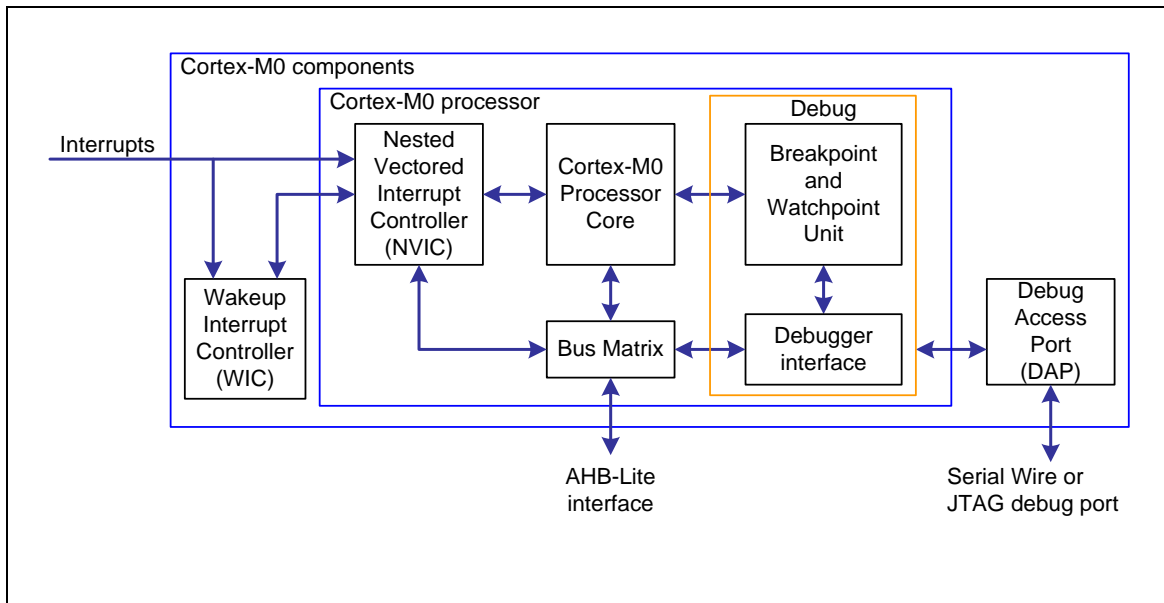

Figure 6-1 Functional Controller Diagram

6.2 Features

- A low gate count processor:
 - ◆ ARMv6-M Thumb® instruction set
 - ◆ Thumb-2 technology
 - ◆ ARMv6-M compliant 24-bit SysTick timer
 - ◆ A 32-bit hardware multiplier
 - ◆ System interface supporting little-endian data accesses
 - ◆ Ability to have deterministic, fixed-latency, interrupt handling
 - ◆ Load/store-multiples and multicycle-multiplies abandoned and restarted to facilitate rapid interrupt handling
 - ◆ C Application Binary Interface compliant exception model. This is the ARMv6-M, C Application Binary Interface (C-ABI) compliant exception model that enables the use of pure C functions as interrupt handlers



- ◆ Low power sleep mode entry using Wait For Interrupt (WFI), Wait For Event (WFE) instructions, or the return from interrupt sleep-on-exit feature
- NVIC :
 - ◆ 32 external interrupt inputs, each with four levels of priority
 - ◆ Dedicated Non-Maskable Interrupt (NMI) input
 - ◆ Supports both level-sensitive and pulse-sensitive interrupt lines
 - ◆ Supports Wake-up Interrupt Controller (WIC) with ultra-low power sleep mode
- Debug support
 - ◆ Four hardware breakpoints
 - ◆ Two watchpoints
 - ◆ Program Counter Sampling Register (PCSR) for non-intrusive code profiling
 - ◆ Single step and vector catch capabilities
- Bus interfaces:
 - ◆ Single 32-bit AMBA-3 AHB-Lite system interface providing simple integration to all system peripherals and memory
 - ◆ Single 32-bit slave port supporting the DAP (Debug Access Port)



6.3 System Timer (SysTick)

The Cortex-M0 includes an integrated system timer, SysTick, which provides a simple, 24-bit clear-on-write, decrementing, wrap-on-zero counter with a flexible control mechanism. The counter can be used as a Real Time Operating System (RTOS) tick timer or as a simple counter.

When system timer is enabled, it will count down from the value in the SysTick Current Value Register (SYST_CVR) to zero, and reload (wrap) to the value in the SysTick Reload Value Register (SYST_RVR) on the next clock cycle, and then decrement on subsequent clocks. When the counter transitions to zero, the COUNTFLAG status bit is set. The COUNTFLAG bit clears on reads.

The SYST_CVR value is UNKNOWN on reset. Software should write to the register to clear it to zero before enabling the feature. This ensures the timer will count from the SYST_RVR value rather than an arbitrary value when it is enabled.

If the SYST_RVR is zero, the timer will be maintained with a current value of zero after it is reloaded with this value. This mechanism can be used to disable the feature independently from the timer enable bit.

For more detailed information, please refer to the “ARM® Cortex™-M0 Technical Reference Manual” and “ARM® v6-M Architecture Reference Manual”.



7 ELECTRICAL CHARACTERISTICS

7.1 Absolute Maximum Ratings

SYMBOL	PARAMETER	MIN	MAX	UNIT
DC Power Supply	$V_{DD}-V_{SS}$	-0.3	+7.0	V
Input Voltage	V_{IN}	$V_{SS}-0.3$	$V_{DD}+0.3$	V
Oscillator Frequency	$1/t_{CLCL}$	4	24	MHz
Operating Temperature	TA	-40	+85	°C
Storage Temperature	TST	-55	+150	°C
Maximum Current into VDD		-	120	mA
Maximum Current out of VSS			120	mA
Maximum Current sunk by an I/O pin			35	mA
Maximum Current sourced by an I/O pin			35	mA
Maximum Current sunk by total I/O pins			100	mA
Maximum Current sourced by total I/O pins			100	mA

Note: Exposure to conditions beyond those listed under absolute maximum ratings may adversely affects the life and reliability of the device.



7.2 DC Electrical Characteristics

7.2.1 NuMicro™ NUC123 DC Electrical Characteristics

(VDD-VSS=3.3 V, TA = 25°C, FOSC = 72 MHz unless otherwise specified.)

PARAMETER	SYM	SPECIFICATIONS				TEST CONDITIONS
		MIN	TYP	MAX	UNIT	
Operation voltage	V _{DD}	2.5		5.5	V	V _{DD} = 2.5V ~ 5.5V up to 72 MHz
VDD rise rate to ensure internal operation correctly	V _{RISE}	0.05			V/ms	
Power ground	V _{SS} AV _{SS}	-0.3			V	
LDO output voltage	V _{LDO}	-10%	1.8	+10%	V	V _{DD} > 2.7V
Analog operating voltage	AV _{DD}	0		V _{DD}	V	
Operating current Normal Run mode at 72 MHz	I _{DD1}		36		mA	V _{DD} = 5.5V at 72 MHz, All IP and PLL Enabled, XTAL = 12 MHz
	I _{DD2}		21		mA	V _{DD} = 5.5V at 72 MHz, All IP Disabled and PLL Enabled, XTAL = 12 MHz
	I _{DD3}		35		mA	V _{DD} = 3V at 72 MHz, All IP and PLL enabled, XTAL = 12 MHz
	I _{DD4}		20		mA	V _{DD} = 3V at 72 MHz, All IP Disabled and PLL Enabled, XTAL = 12 MHz
Operating current Normal Run mode at 12 MHz	I _{DD5}		7		mA	V _{DD} = 5.5V at 12 MHz, All IP Enabled and PLL Disabled, XTAL = 12 MHz
	I _{DD6}		4		mA	V _{DD} = 5.5V at 12 MHz, All IP and PLL Disabled, XTAL = 12 MHz
	I _{DD7}		6		mA	V _{DD} = 3V at 12 MHz, All IP Enabled and PLL Disabled, XTAL = 12 MHz



PARAMETER	SYM	SPECIFICATIONS				TEST CONDITIONS
		MIN	TYP	MAX	UNIT	
	I _{DD8}		3		mA	V _{DD} = 3V at 12 MHz, All IP and PLL Disabled, XTAL = 12 MHz
Operating current Normal Run mode at 4 MHz	I _{DD9}		4		mA	V _{DD} = 5V at 4 MHz, All IP Enabled and PLL Disabled, XTAL = 4 MHz
	I _{DD10}		3		mA	V _{DD} = 5V at 4 MHz, All IP and PLL Disabled, XTAL = 4 MHz
	I _{DD11}		4		mA	V _{DD} = 3V at 4 MHz, All IP Enabled and PLL Disabled, XTAL = 4 MHz
	I _{DD12}		2		mA	V _{DD} = 3V at 4 MHz, All IP and PLL Disabled, XTAL = 4 MHz
Operating current Idle mode at 72 MHz	I _{IDLE1}		29		mA	V _{DD} = 5.5V at 72 MHz, All IP and PLL Enabled, XTAL = 12 MHz
	I _{IDLE2}		14		mA	V _{DD} = 5.5V at 72 MHz, All IP Disabled and PLL Enabled, XTAL = 12 MHz
	I _{IDLE3}		28		mA	V _{DD} = 3V at 72 MHz, All IP and PLL Enabled, XTAL = 12 MHz
	I _{IDLE4}		13		mA	V _{DD} = 3V at 72 MHz, All IP Disabled and PLL Enabled, XTAL=12 MHz
Operating current Idle mode at 12 MHz	I _{IDLE5}		6		mA	V _{DD} = 5.5V at 12 MHz, All IP Enabled and PLL Disabled, XTAL = 12 MHz
	I _{IDLE6}		3		mA	V _{DD} = 5.5V at 12 MHz, All IP and PLL Disabled, XTAL = 12 MHz
	I _{IDLE7}		5		mA	V _{DD} = 3V at 12 MHz, All IP Enabled and PLL Disabled, XTAL = 12 MHz



PARAMETER	SYM	SPECIFICATIONS				TEST CONDITIONS
		MIN	TYP	MAX	UNIT	
	I _{IDLE8}		2		mA	V _{DD} = 3 V at 12 MHz, All IP and PLL Disabled, XTAL = 12 MHz
Operating current Idle mode at 4 MHz	I _{IDLE9}		3		mA	V _{DD} = 5V at 4 MHz, All IP Enabled and PLL Disabled, XTAL = 4 MHz
	I _{IDLE10}		2		mA	V _{DD} = 5V at 4 MHz, All IP and PLL Disabled, XTAL = 4 MHz
	I _{IDLE11}		2		mA	V _{DD} = 3V at 4 MHz, All IP Enabled and PLL Disabled, XTAL = 4 MHz
	I _{IDLE12}		1		mA	V _{DD} = 3V at 4 MHz, All IP and PLL Disabled, XTAL = 4 MHz
Operating current Idle mode at 10 kHz	I _{IDLE5}		131		μA	V _{DD} = 5.5V at 10 kHz, All IP Enabled and PLL Disabled, LIRC 10 kHz Enabled
	I _{IDLE6}		129		μA	V _{DD} = 5.5V at 10 kHz, All IP and PLL Disabled, LIRC 10 kHz Enabled
	I _{IDLE7}		125		μA	V _{DD} = 3V at 10 kHz, All IP Enabled and PLL Disabled, LIRC 10 kHz Enabled
	I _{IDLE8}		124		μA	V _{DD} = 3 V at 10 kHz, All IP and PLL Disabled, LIRC 10 kHz Enabled
Standby current Power-down mode	I _{PWD1}		12		μA	V _{DD} = 5.5V, No load when BOV function Disabled
	I _{PWD2}		9		μA	V _{DD} = 3.3V, No load when BOV function Disabled
Input Current PA, PB, PC, PD, PE, PF (Quasi- bidirectional mode)	I _{IN1}		-64		μA	V _{DD} = 5.5V, V _{IN} = 0V or V _{IN} = V _{DD}
Input Current at /RESET ^[1]	I _{IN2}	-55	-45	-30	μA	V _{DD} = 3.3V, V _{IN} = 0.45V
Input Leakage Current PA, PB, PC, PD, PE, PF	I _{LK}	-2	-	+2	μA	V _{DD} = 5.5V, 0 < V _{IN} < V _{DD}



PARAMETER	SYM	SPECIFICATIONS				TEST CONDITIONS
		MIN	TYP	MAX	UNIT	
Logic 1 to 0 Transition Current PA~PF (Quasi-bidirectional mode)	$I_{TL}^{[3]}$	-650	-	-200	μA	$V_{DD} = 5.5V, V_{IN} < 2.0V$
Input Low Voltage PA, PB, PC, PD, PE, PF (TTL input)	V_{IL1}	-0.3	-	0.8	V	$V_{DD} = 4.5V$
		-0.3	-	0.6		$V_{DD} = 2.5V$
Input High Voltage PA, PB, PC, PD, PE, PF (TTL input)	V_{IH1}	2.0	-	$V_{DD} + 0.2$	V	$V_{DD} = 5.5V$
		1.5	-	$V_{DD} + 0.2$		$V_{DD} = 3.0V$
Input Low Voltage PA, PB, PC, PD, PE, PF (Schmitt input)	V_{IL2}	-0.5	-	$0.35 V_{DD}$	V	
Input High Voltage PA, PB, PC, PD, PE, PF (Schmitt input)	V_{IH2}	$0.65 V_{DD}$	-	$V_{DD} + 0.5$	V	
Hysteresis voltage of PA~PE (Schmitt input)	V_{HY}		$0.2 V_{DD}$		V	
Input Low Voltage XT1 ^[*2]	V_{IL3}	0	-	0.8	V	$V_{DD} = 4.5V$
		0	-	0.4		$V_{DD} = 3.0V$
Input High Voltage XT1 ^[*2]	V_{IH3}	3.5	-	$V_{DD} + 0.2$	V	$V_{DD} = 5.5V$
		2.4	-	$V_{DD} + 0.2$		$V_{DD} = 3.0V$
Negative going threshold (Schmitt input), /RESET	V_{ILS}	-0.5	-	$0.2 V_{DD}$	V	
Positive going threshold (Schmitt input), /RESET	V_{IHS}	$0.6 V_{DD}$	-	$V_{DD} + 0.5$	V	
Source Current PA, PB, PC, PD, PE, PF (Quasi- bidirectional Mode)	I_{SR11}	-300	-370	-450	μA	$V_{DD} = 4.5V, V_S = 2.4V$
	I_{SR12}	-50	-70	-90	μA	$V_{DD} = 2.7V, V_S = 2.2V$
	I_{SR12}	-40	-60	-80	μA	$V_{DD} = 2.5V, V_S = 2.0V$
Source Current PA, PB, PC, PD, PE, PF (Push-pull Mode)	I_{SR21}	-20	-24	-28	mA	$V_{DD} = 4.5V, V_S = 2.4V$
	I_{SR22}	-4	-6	-8	mA	$V_{DD} = 2.7V, V_S = 2.2V$
	I_{SR22}	-3	-5	-7	mA	$V_{DD} = 2.5V, V_S = 2.0V$
Sink Current PA, PB, PC, PD, PE, PF (Quasi-bidirectional and Push-pull Mode)	I_{SK1}	10	16	20	mA	$V_{DD} = 4.5V, V_S = 0.45V$
	I_{SK1}	7	10	13	mA	$V_{DD} = 2.7V, V_S = 0.45V$
	I_{SK1}	6	9	12	mA	$V_{DD} = 2.5V, V_S = 0.45V$



PARAMETER	SYM	SPECIFICATIONS				TEST CONDITIONS
		MIN	TYP	MAX	UNIT	
Brown-out voltage with BOV_VL [1:0] =00b	V _{BO2.2}	2.1	2.2	2.3	V	
Brown-out voltage with BOV_VL [1:0] =01b	V _{BO2.7}	2.6	2.7	2.8	V	
Brown-out voltage with BOV_VL [1:0] =10b	V _{BO3.8}	3.7	3.8	3.9	V	
Brown-out voltage with BOV_VL [1:0] =11b	V _{BO4.5}	4.4	4.5	4.6	V	
Hysteresis range of BOD voltage	V _{BH}	30	-	150	mV	V _{DD} = 2.5V - 5.5V

Notes:

1. /RESET pin is a Schmitt trigger input.
2. Crystal Input is a CMOS input.
3. Pins of PA, PB, PC, PD and PE can source a transition current when they are being externally driven from 1 to 0. In the condition of V_{DD}=5.5 V, the transition current reaches its maximum value when V_{IN} approximates to 2V.



7.3 AC Electrical Characteristics

7.3.1 External 4~24 MHz High Speed Oscillator

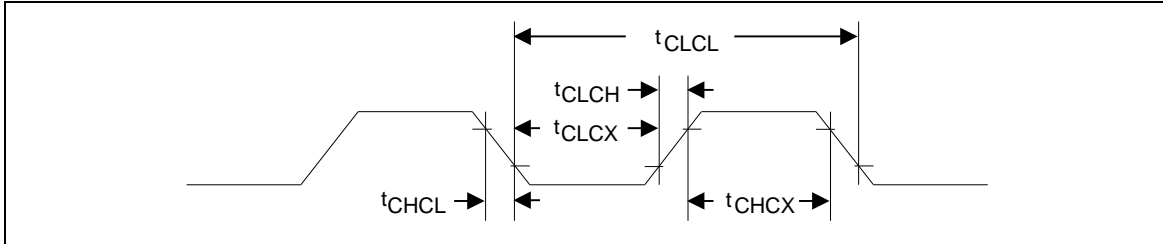

Note: Duty cycle is 50%.

SYMBOL	PARAMETER	CONDITIONS	MIN	TYP	MAX	UNIT
t _{CHCX}	Clock High Time		20	-	-	nS
t _{CLCX}	Clock Low Time		20	-	-	nS
t _{CLCH}	Clock Rise Time		-	-	10	nS
t _{CHCL}	Clock Fall Time		-	-	10	nS

7.3.2 External 4~24 MHz High Speed Crystal

PARAMETER	CONDITIONS	MIN	TYP	MAX	UNIT
Input clock frequency	External crystal	4	12	24	MHz
Temperature	-	-40	-	85	°C
VDD	-	2.5	5	5.5	V

7.3.2.1 Typical Crystal Application Circuits

CRYSTAL	C1	C2	R
4 MHz ~ 24 MHz	without	without	without

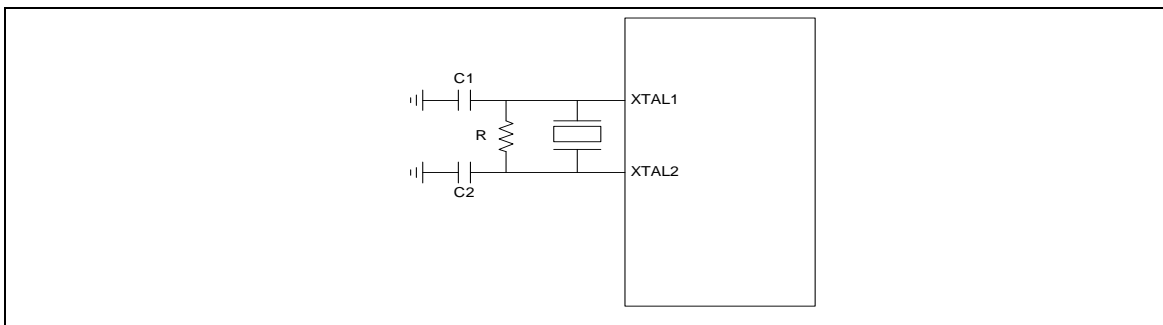

Figure 7-1 Typical Crystal Application Circuit



7.3.3 Internal 22.1184 MHz High Speed Oscillator

PARAMETER	CONDITIONS	MIN	TYP	MAX	UNIT
Supply voltage ^[1]	-	2.5	-	5.5	V
Center Frequency	-	-	22.1184	-	MHz
Calibrated Internal Oscillator Frequency	+25 C; V _{DD} =5 V	-1	-	+1	%
	-40 C~+85 C; V _{DD} =2.5 V~5.5 V	-3	-	+3	%
Operation Current	V _{DD} =5 V	-	500	-	uA

7.3.4 Internal 10 kHz Low Speed Oscillator

PARAMETER	CONDITIONS	MIN	TYP	MAX	UNIT
Supply voltage ^[1]	-	2.5	-	5.5	V
Center Frequency	-	-	10	-	kHz
Calibrated Internal Oscillator Frequency	+25 C; V _{DD} =5 V	-30	-	+30	%
	-40 C~+85 C; V _{DD} =2.5 V~5.5 V	-50	-	+50	%

Note: Internal operation voltage comes from LDO.



7.4 Analog Characteristics

7.4.1 10-bit SARADC Specifications

PARAMETER	SYM	SPECIFICATIONS				TEST CONDITIONS
		MIN	TYP	MAX	UNIT	
Operating Voltage	A_{VDD}	2.7		5.5	V	$A_{VDD} = V_{DD}$
Operating Current	I_{ADC}			1.5	mA	$A_{VDD} = V_{DD} = 5V$, $F_{SPS} = 150K$
Resolution	R_{ADC}			10	bit	
Reference Voltage	V_{REF}		A_{VDD}		V	V_{REF} Connected to A_{VDD} in Chip
ADC input Voltage	V_{IN}	0		A_{VDD}	V	
Sampling Rate	F_{SPS}	150K			Hz	$V_{DD} = 5V$, ADC Clock = 6MHz Free Running Conversion
Integral Non-linearity Error (INL)	INL			± 1	LSB	
Differential Non-linearity Error (DNL)	DNL			± 1	LSB	
Gain Error	E_G			± 2	LSB	
Offset Error	E_{OFFSET}		3		LSB	
Absolute Error	E_{ABS}		4		LSB	
ADC Clock Frequency	F_{ADC}	100K		6M	Hz	$V_{DD} = 5V$
Clock Cycle	AD_{CYC}	36			Cycle	
Bang-gap Voltage	V_{BG}	1.27	1.35	1.44	V	$-40^{\circ}C \sim +85^{\circ}C$



7.4.2 LDO and Power Management Specifications

PARAMETER	MIN	TYP	MAX	UNIT	NOTE
Input Voltage	2.7	5	5.5	V	V _{DD} input voltage
Output Voltage	-10%	2.5	+10%	V	V _{DD} > 2.7V
Temperature	-40	25	85	°C	
Quiescent Current (PD = 0)	-	100	-	uA	
Quiescent Current (PD = 1)	-	5	-	uA	
Iload (PD = 0)	-	-	100	mA	
Iload (PD = 1)	-	-	100	uA	
Cbp	-	1	-	uF	Resr = 1Ω

Notes:

1. It is recommended that a 10uF or higher capacitor and a 100nF bypass capacitor are connected between VDD and the closest VSS pin of the device.
2. To ensure power stability, a 1uF (Cbp) or higher capacitor must be connected between LDO pin and the closest VSS pin of the device.

7.4.3 Low Voltage Reset Specifications

PARAMETER	CONDITIONS	MIN	TYP	MAX	UNIT
Operation voltage	-	1.7	-	5.5	V
Quiescent current	VDD5V= 5.5 V	-	-	5	uA
Temperature	-	-40	25	85	°C
Threshold voltage	Temperature = 25°C	1.7	2.0	2.3	V
	Temperature = -40°C	-	2.4	-	V
	Temperature = 85°C	-	1.6	-	V
Hysteresis	-	0	0	0	V



7.4.4 Brown-out Detector Specifications

PARAMETER	CONDITIONS	MIN	TYP	MAX	UNIT
Operation voltage	-	2.5	-	5.5	V
Quiescent current	AVDD = 5.5 V	-	-	125	μA
Temperature	-	-40	25	85	°C
Brown-out voltage	BOV_VL[1:0] = 11	4.4	4.5	4.6	V
	BOV_VL [1:0] = 10	3.7	3.8	3.9	V
	BOV_VL [1:0] = 01	2.6	2.7	2.8	V
	BOV_VL [1:0] = 00	2.1	2.2	2.3	V
Hysteresis	-	30	-	150	mV

7.4.5 Power-On Reset (5V) Specifications

PARAMETER	CONDITIONS	MIN	TYP	MAX	UNIT
Temperature	-	-40	25	85	°C
Reset voltage	V+	-	2	-	V
Quiescent current	Vin>reset voltage	-	1	-	nA



7.4.6 USB PHY Specifications

7.4.6.1 USB DC Electrical Characteristics

SYMBOL	PARAMETER	CONDITIONS	MIN	TYP	MAX	UNIT
V _{IH}	Input high (driven)		2.0			V
V _{IL}	Input low				0.8	V
V _{DI}	Differential input sensitivity	PADP-PADM	0.2			V
V _{CM}	Differential common-mode range	Includes V _{DI} range	0.8		2.5	V
V _{SE}	Single-ended receiver threshold		0.8		2.0	V
	Receiver hysteresis			200		mV
V _{OL}	Output low (driven)		0		0.3	V
V _{OH}	Output high (driven)		2.8		3.6	V
V _{CRS}	Output signal cross voltage		1.3		2.0	V
R _{PU}	Pull-up resistor		1.425		1.575	kΩ
R _{PD}	Pull-down resistor		14.25		15.75	kΩ
V _{TRM}	Termination Voltage for upstream port pull up (RPU)		3.0		3.6	V
Z _{DRV}	Driver output resistance	Steady state drive*		10		Ω
C _{IN}	Transceiver capacitance	Pin to GND			20	pF

Note: Driver output resistance doesn't include series resistor resistance.

7.4.6.2 USB Full-Speed Driver Electrical Characteristics

SYMBOL	PARAMETER	CONDITIONS	MIN	TYP	MAX	UNIT
T _{FR}	Rising time	C _L = 50p	4		20	ns
T _{FF}	Falling time	C _L = 50p	4		20	ns
T _{FRFF}	Rising and falling time matching	T _{FRFF} = T _{FR} /T _{FF}	90		111.11	%

7.4.6.3 USB Power Dissipation

SYMBOL	PARAMETER	CONDITIONS	MIN	TYP	MAX	UNIT
I _{VDDREG} (Full speed)	V _{DDD} and V _{DDREG} supply current (steady state)	Standby		50		uA
		Input mode				uA
		Output mode				uA



7.5 SPI Dynamic Characteristics

SYMBOL	PARAMETER	MIN	TYP	MAX	UNIT
SPI Master mode (VDD = 4.5V ~ 5.5V, 30pF loading Capacitor)					
t_{DS}	Data setup time	TBD	TBD	-	ns
t_{DH}	Data hold time	TBD	-	-	ns
t_V	Data output valid time	-	TBD	TBD	ns
SPI Master mode (VDD = 3.0V ~ 3.6V, 30pF loading Capacitor)					
t_{DS}	Data setup time	TBD	TBD	-	ns
t_{DH}	Data hold time	TBD	-	-	ns
t_V	Data output valid time	-	TBD	TBD	ns
SPI Slave mode (VDD = 4.5V ~ 5.5V, 30pF loading Capacitor)					
t_{DS}	Data setup time	TBD	-	-	ns
t_{DH}	Data hold time	TBD	-	-	ns
t_V	Data output valid time	-	TBD	TBD	ns
SPI Slave mode (VDD = 3.0V ~ 3.6V, 30pF loading Capacitor)					
t_{DS}	Data setup time	TBD	-	-	ns
t_{DH}	Data hold time	TBD	-	-	ns
t_V	Data output valid time	-	TBD	TBD	ns

TBD: To be defined.

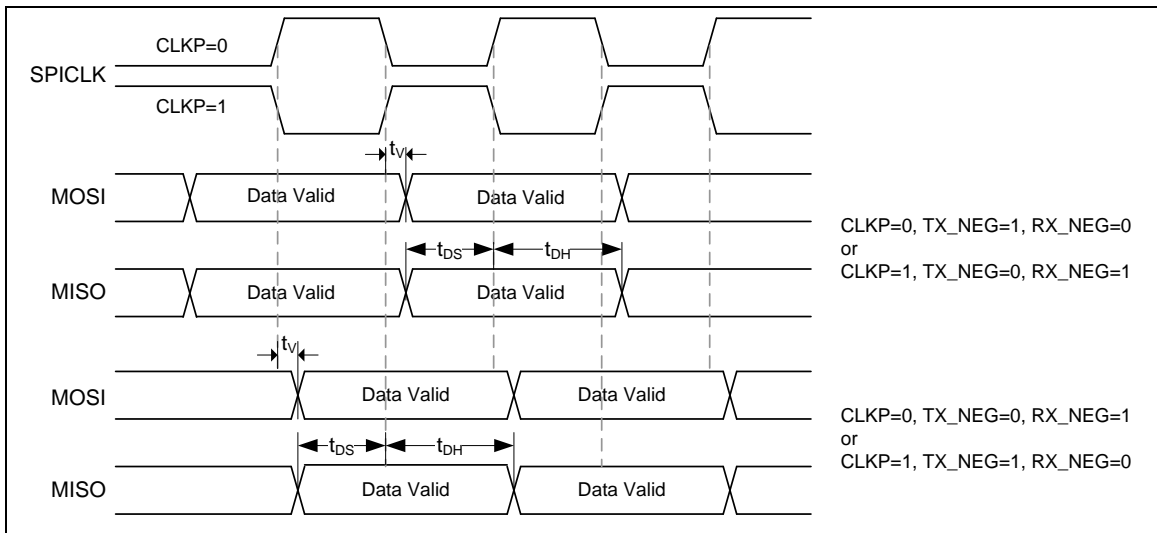

Figure 7-2 SPI Master Dynamic Characteristics Timing

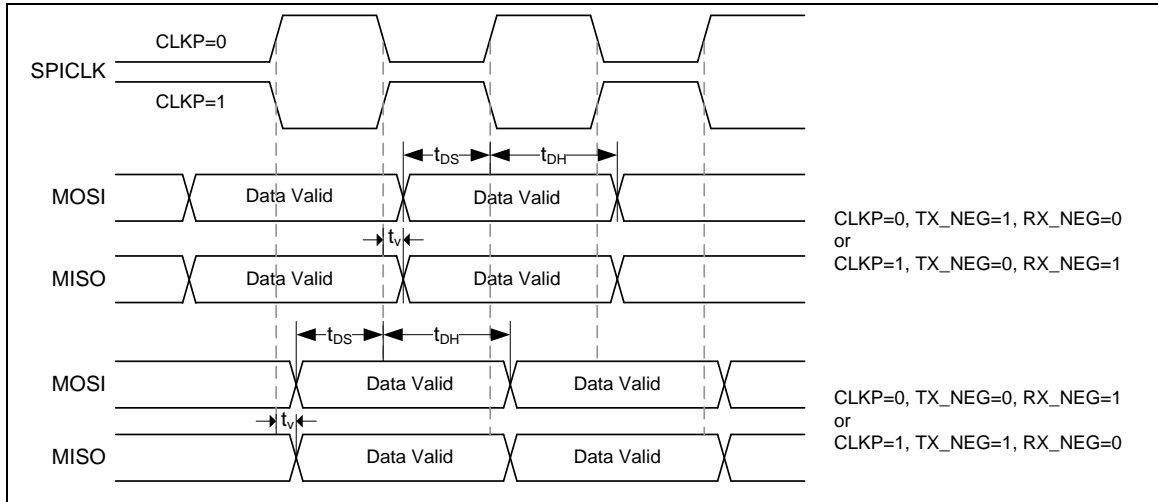
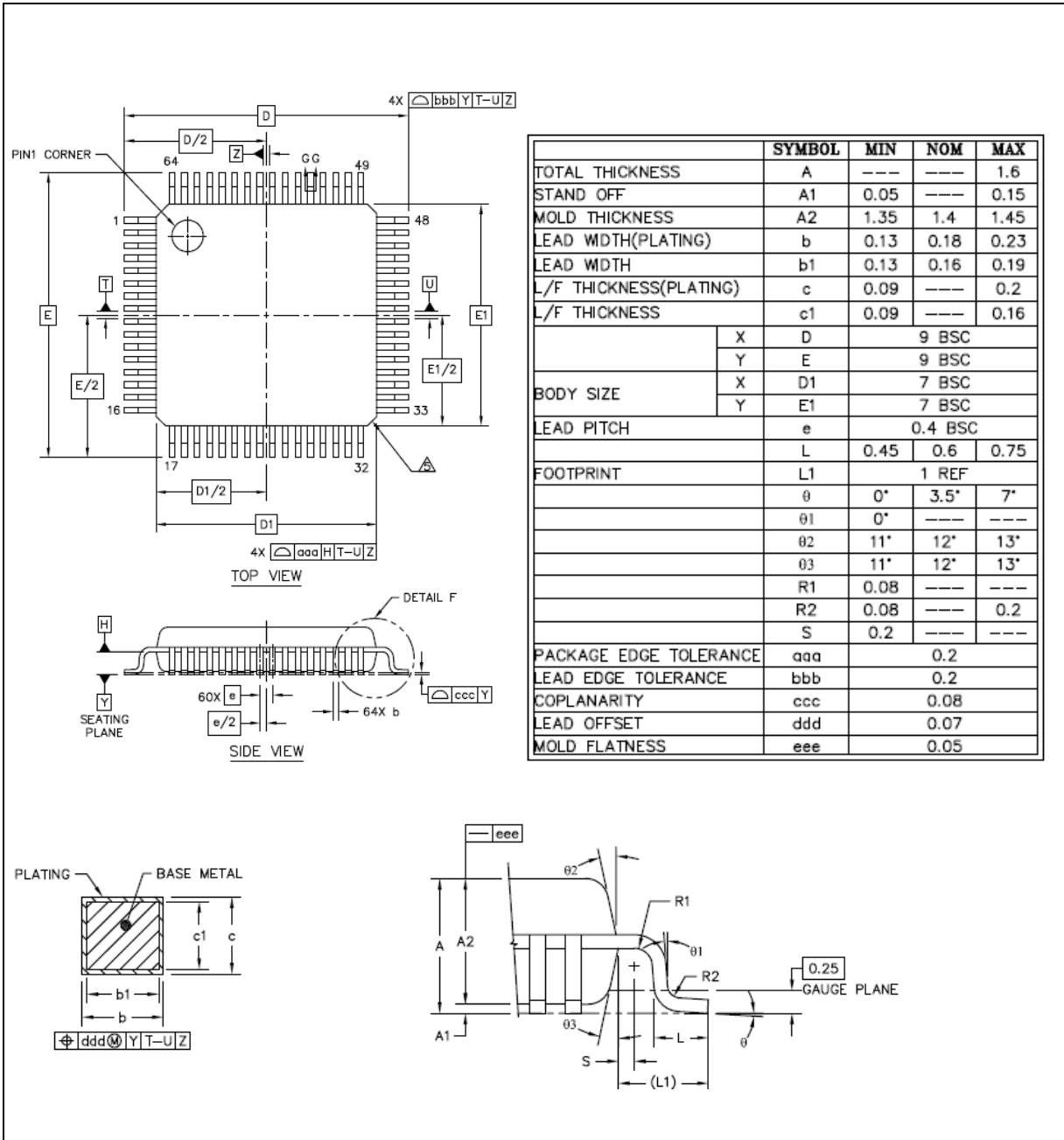

Figure 7-3 SPI Slave Dynamic Characteristics Timing



8 PACKAGE DIMENSIONS

8.1 64L LQFP (7x7x1.4 mm footprint 2.0 mm)





8.2 48L LQFP (7x7x1.4 mm footprint 2.0 mm)

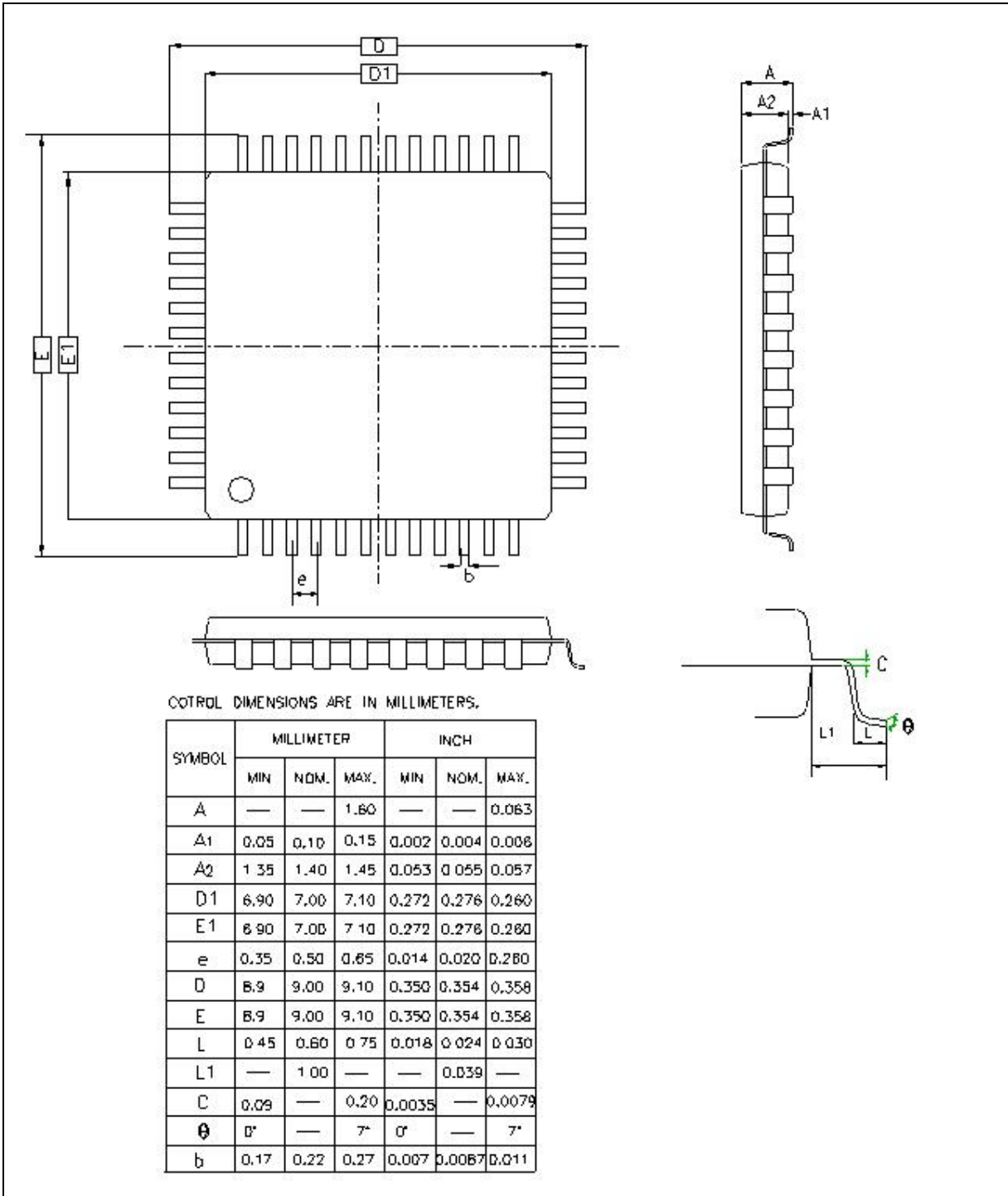



8.3 33L QFN (5x5x0.8 mm)

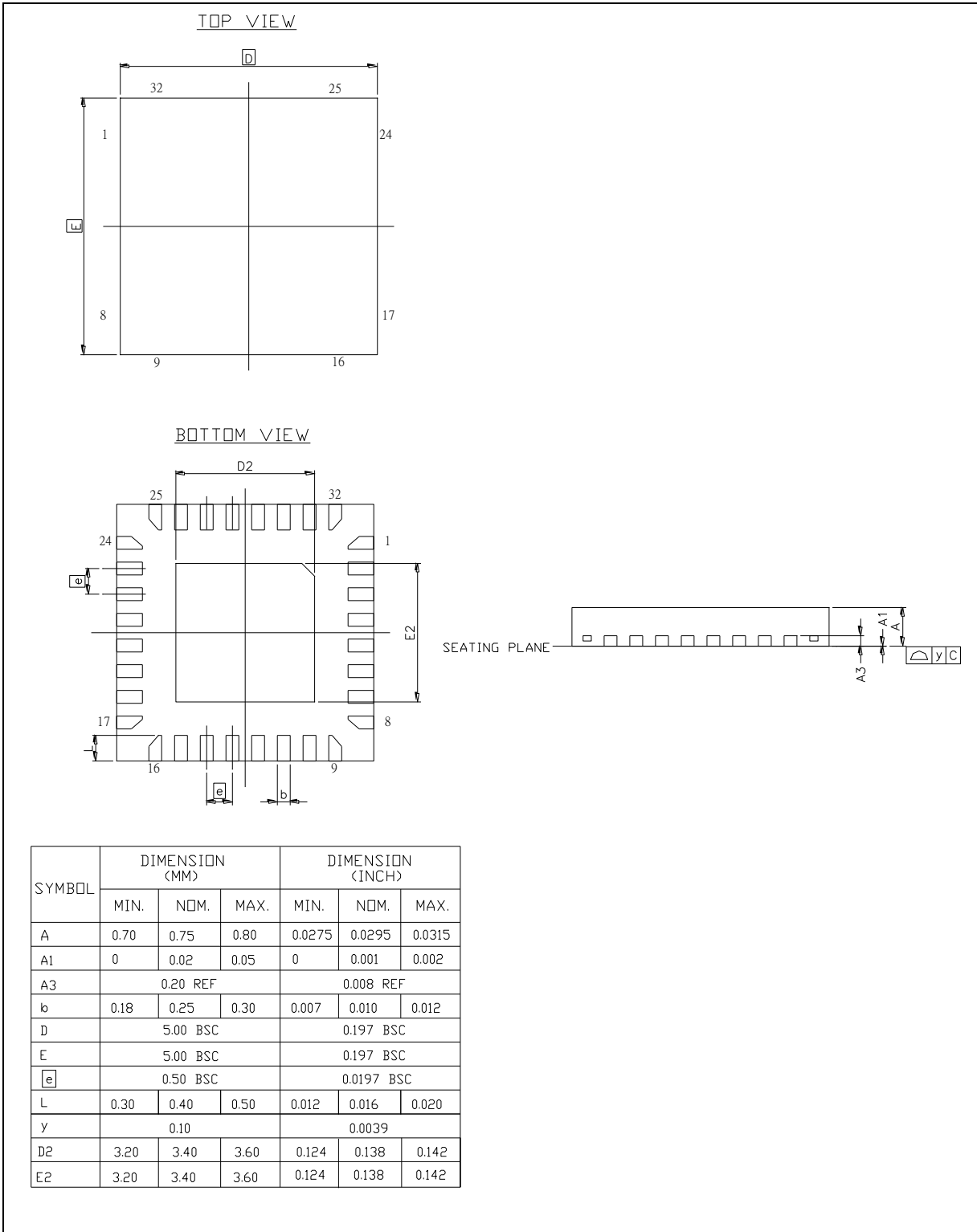



9 REVISION HISTORY

VERSION	DATE	PAGE/ CHAPTER	DESCRIPTION
V1.00	Mar 27, 2012	-	Preliminary issued version
V1.01	May 2, 2012	Chap. 7	Update Section 7.2 DC Electrical Characteristics
V1.02	May 7, 2012	Chap. 3	Update Figure 3-1 NuMicro™ NUC123 Series Selection Code
V1.03	May 14, 2012	Chap. 3	Modify the Pin Assignment and Pin Description for LQFP 64-pin and LQFP 48-pin
V1.04	May 30, 2012	Chap. 3	Modify the Pin Assignment and Pin Description for PC.12 pin.
V1.05	July 20, 2012	Chap. 5 Chap. 7	<p>Modify Overview and Features in Section 5.10 Serial Peripheral Interface (SPI).</p> <p>Remove 32.768kHz crystal characteristics in Section 7.3 AC Electrical Characteristics</p> <p>Modify the Overview and Features in Section 5.10 Serial Peripheral Interface (SPI)</p> <p>Modify the capacitor value from 10uF to 1uF for the LDO pin in Figure 5-1 NuMicro™ NUC123 Power Distribution Diagram and Section 7.4.2 LDO and Power Management Specifications.</p>
V1.06	Aug. 21, 2012	Chap. 2 Chap. 4 Chap. 5 Chap. 7	<p>Update the SPI item for “Master up to 32 MHz, and Slave up to 16 MHz” in Section 2.1 NuMicro™ NUC123 Features.</p> <p>Update the Packages item for “LQFP 64-pin” in Section 2.1 NuMicro™ NUC123 Features.</p> <p>Update Figure 4-1 NuMicro™ NUC123 Block Diagram.</p> <p>Update the maximum ADC clock to 6 MHz and ADC conversion rate to 150K SPS in Features of Section 5.17 Analog-to-Digital Converter (ADC).</p> <p>Update the 10-bit SARADC Specifications in Section 7.4 Analog Characteristics.</p>



Important Notice

Nuvoton Products are neither intended nor warranted for usage in systems or equipment, any malfunction or failure of which may cause loss of human life, bodily injury or severe property damage. Such applications are deemed, “Insecure Usage”.

Insecure usage includes, but is not limited to: equipment for surgical implementation, atomic energy control instruments, airplane or spaceship instruments, the control or operation of dynamic, brake or safety systems designed for vehicular use, traffic signal instruments, all types of safety devices, and other applications intended to support or sustain life.

All Insecure Usage shall be made at customer’s risk, and in the event that third parties lay claims to Nuvoton as a result of customer’s Insecure Usage, customer shall indemnify the damages and liabilities thus incurred by Nuvoton.

*Please note that all data and specifications are subject to change without notice.
All the trademarks of products and companies mentioned in this datasheet belong to their respective owners.*