

MC9S12A64

Target Applications

- > Instrumentation
- > Energy management
- > Industrial control
- > Robotics
- > Safety equipment
- > Security

Overview

The MC9S12A64 Flash microcontroller (MCU) is the next generation of the highly successful 68HC12 architecture. Utilizing Freescale's industry-leading 0.25µ Flash, the A64 is part of a pin-compatible family that is planned to scale from 32 KB to 512 KB of Flash memory. The MC9S12A64 provides an upward migration path from Freescale's 68HC08, 68HC11 and 68HC12 architectures for applications that need larger memory, more peripherals and higher performance.

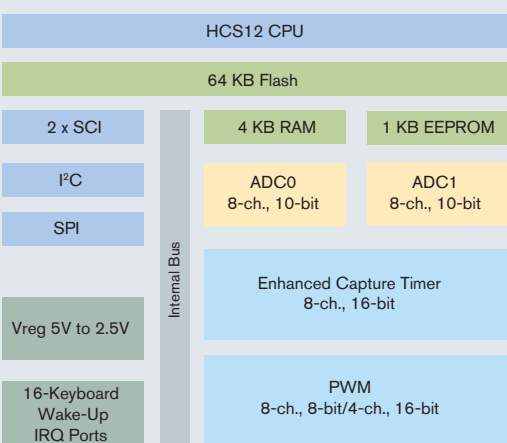

Features

Benefits

High-Performance 16-bit HCS12 CPU Core

- > 25 MHz bus operation at 5V for 40 ns minimum instruction cycle time

- > Opcode compatible with the 68HC11 and 68HC12

- > C-optimized architecture produces extremely compact code

On-Chip Debug Interface

- > Dedicated serial debug interface
- > On-chip breakpoints

- > Real-time in-circuit emulation and debug without expensive and cumbersome box emulators

- > Read/write memory and registers while running at full speed

Integrated Third-Generation Flash Memory

- > In-application reprogrammable
- > Self-timed, fast programming
 - Fast Flash page erase—20 ms (512 bytes)
 - Can program 16 bits in 20 µs while in burst mode
- > 5V Flash program/erase/read
- > Flash granularity—512 byte Flash erase/2 byte Flash program
- > Flexible block protection and security
- > Flexibility to change code in the field

- > Efficient end-of-line programming
- > Total program time for 164 KB code is less than 5s
- > Reduces production programming cost through ultra-fast programming
- > No external high voltage or charge pump required
- > Virtual EEPROM implementation, Flash array usable for EE extension

1 KB Integrated EEPROM

- > Flexible protection scheme for protection against accidental program or erase
- > EEPROM can be programmed in 46 µs

- > Can erase 4 bytes at a time and program 2 bytes at a time for calibration, security, personality and diagnostic information

10-bit Analog-to-Digital Converter (ADC)

- > Two eight-channel ADCs
- > 7 µs, 10-bit single conversion time, scan mode available

- > Fast, easy conversion from analog inputs, such as position sensors, analog meters and photovoltaic cells, to digital values for CPU processing

- > Can effectively have 3.5 µs conversion time by sampling same signal with both ADCs

Clock Generation Module with Phase-Lock Loop (PLL)

- > Clock monitor with limp home mode in case of no external clock
- > Programmable clock frequency with 1,024 options ranging from divide by 16 to multiply by 64 from base oscillator
- > Real-time interrupt
- > Watchdog

- > Reliable, robust operation
- > Provides high performance using low-cost reference crystals
- > Reduces generated noise
- > Reduces power consumption
- > Easily able to implement real-time clock

Features	Benefits
Enhanced Capture Timer	
> 8-channel, 16-bit with input capture, output compare and pulse accumulator	> Flexible, programmable timer system
> 16-bit modulus down counter	
8-bit or 16-bit Pulse-Width Modulation (PWM)	
> 8-channel, 8-bit or 4-channel, 16-bit PWM	> Efficiently implements motor control, battery charging or digital-to-analog functions
> PWM supports center-aligned operation	
Two Serial Communications Interfaces (SCIs)	
> 8192 prescaler options	> Asynchronous communication between the MCU and a terminal, computer or a network of microcontrollers
	> Exact baud rate matching
One Serial Peripheral Interface (SPI)	
> Up to 12.5 Mbps	> High-speed synchronous communication between multiple MCUs or between MCU and serial peripherals
Inter-IC (I²C) Bus	
> 256 clock-rate options	> Provides a simple, efficient method of data exchange between devices
	> Minimizes the need for large numbers of connections between devices and eliminates the need for an address decoder
Up to 91 Input/Output (I/O) Lines	
> Programmable pull-ups/pull-downs	> Reduce system cost
> Dual drive capability	> Able to tailor application for minimum EMC or high current loads

Application Notes and Engineering Bulletins

AN1284	Transporting M68HC11 Code to M68HC12 Devices
AN1716	Using M68HC12 Indexed Indirect Addressing
AN1775	Expanding Digital Input with an A/D Converter
AN1783	Determining MCU Oscillator Start-Up Parameters
AN2104	Using Background Debug Mode for the M68HC12 Family
AN2204	Fast NVM Programming for the MC9S12DP256
AN2216	MC9S12DP256 Software Development Using Metrowerks CodeWarrior™
AN2318	Using the I ² C Bus with HCS12 Microcontrollers
EB396	Use of OSC2/XTAL As a Clock Output on Motorola Microcontrollers

Learn More: For more information about Freescale products, please visit www.freescale.com.

Data Sheets

9S12DJ64DGV1	MC9S12DJ64 Device User Guide
S12DJ64PIMV1	PIM 9DJ64 Block Guide
S12BDMV4	Background Debug Module (BDM) V4
S12BKPV1	Breakpoint (BKP) Module V1 Block User Guide
S12INTV1	Interrupt (INT) Module V1
S12MMCV4	Module Mapping Control (MMC) V4
S12MEBIV3	Multiplexed External Bus Interface (MEBI) ModulV3 Block User Guide
S12CPUV2	S12CPUV2 Reference Manual
S12CRGV4	CRG Block User Guide
S12ECT16B8CV1	ECT 16B8C Block User Guide
S12ATD10B8CV2	ATD 10B8C Block User Guide
SC12IICV2	HCS12 Inter-Integrated Circuit (I ² C) Block Guide
S12SPIV2	SPI Block User Guide
S12SCIV2	HCS12 Serial Communications Interface (SCI) Block Guide
S12PWM8B8CV1	PWM 8B8C Block User Guide
S12EETS1KV1	EETS1K Block User Guide
S12FTS64KV1	FTS64K Block User Guide
S12BDLCV1	BDLC Block Guide
S12VREGV1	VREG Block User Guide
S12OSCV2	OSC Block User Guide

Development Tools

USBMULTILINKBDM	Universal HC12/HCS12 in-circuit emulator, debugger and Flash programming through BDM interface
M68KIT912DP256	Includes M68MULTILINK12 and an MC9S12DP256 evaluation board
M68CYCLONEPRO	HC08/HCS08/HC12/HCS12 stand-alone Flash programmer or in-circuit emulator, debugger and Flash programmer; USB, serial or Ethernet interface options
CWX-H12-SE:	CodeWarrior™ Development Studio for HCS12 with Processor Expert™ autocode generator, full-chip simulation, assembler, linker and C compiler (code size limited—compiler upgrades available)

Package Options

Part Number	Package	Temp Range
MC9S12A64CFU	80 QFP	-40°C to +85°C
MC9S12A64CPV	112 QFP	-40°C to +85°C

