

THIRD ANGLE PROJECTION

ITEM CODE	CAPACITANCE μF (*)	DIMENSIONS				
		L	T	H	H <sub>1</sub>	d
ECWFD2W104 () 4	0.1 (104)	12.6	4.5	8.9	30.9	0.6
" 2W124 () 4	0.12 (124)	"	4.6	9.0	31.0	"
" 2W154 () 4	0.15 (154)	"	4.6	9.1	31.1	"
" 2W184 () 4	0.18 (184)	"	4.8	9.3	31.3	"
" 2W224 () 4	0.22 (224)	"	5.0	9.6	31.6	"
" 2W274 () 4	0.27 (274)	"	5.3	10.0	32.0	"
" 2W334 () 4	0.33 (334)	"	5.6	10.4	32.4	"
" 2W394 () 4	0.39 (394)	"	6.0	10.7	32.7	"

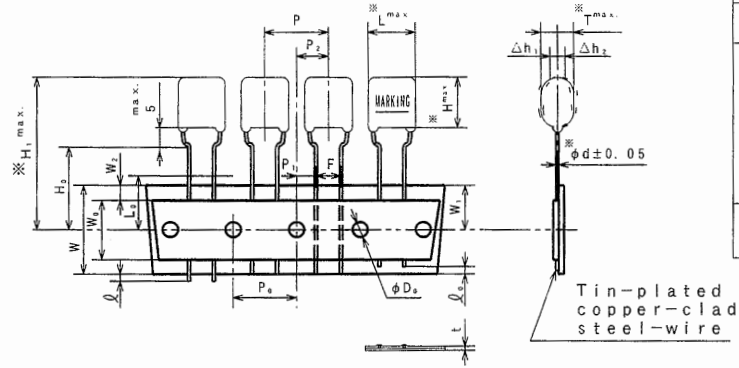

ALTERATION		
ISSUE	DESCRIPTION	DATE
△	Company name changed	Apr. 1 2013

ITEM CODE NUMBER STRUCTURE

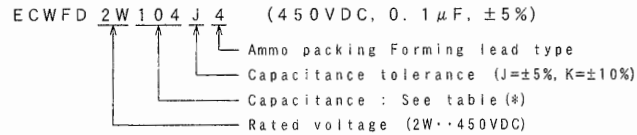

MARKING EXAMPLE

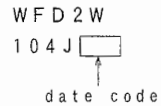

SYMBOL	ITEM	VALUE	TOLERANCE	REMARKS
P	Pitch of component	15.0	±1.0	Tilt of component and curvature of leads shall be included.
P <sub>0</sub>	Feed hole pitch	15.0	±0.2	
P <sub>1</sub>	Feed hole center to lead	3.75	±0.5	
P <sub>2</sub>	Hole center to comp. center	7.5	±1.3	Tilt of component due to curvature of leads shall be included.
F	Lead-to-lead distance	7.5	+0.8 -0.2	
Δh <sub>1,2</sub>	Component alignment	0~2.0		Tilt of component due to curvature of leads shall be included.
W	Paper backing width	18.0	±0.5	
W <sub>0</sub>	Adhesive tape width	12.5	min.	The hold down tape shall not protrude beyond the carrier tape.
W <sub>1</sub>	Hole position	9.0	±0.5	
W <sub>2</sub>	Hold-down tape position	0~3.0		
H <sub>0</sub>	Lead-wire clinch height	16.0	+1.0 0	
ℓ	Lead wire protrusion	0	max.	
ℓ <sub>0</sub>	Lead wire depression	7.0	max.	
φD <sub>0</sub>	Feed hole diameter	4.0	±0.2	
t	Total tape thickness	0.7	±0.2	Total thickness including the hold down tape.
L <sub>0</sub>	Length of snapped lead	11.0	max.	

CONSTRUCTION

The capacitor is of non-inductive construction, wound with metallized polypropylene film dielectric.  
 The capacitor is enclosed in non-combustible epoxy resin and has two leads.

MARKING

Marking comprises capacitance, capacitance tolerance, rated voltage and date code.

PROPERTIES

- \*Capacitance : See table at 1kHz.
- \*Capacitance tolerance : ±5% (J), ±10% (K) at 1kHz.
- \*Rated voltage : 450VDC  
 (Derating of rated voltage by 0.62%/°C at more than 85°C)
- \*Withstand voltage (terminal-terminal) : 450VDCX150% for 60s
- \*Insulation resistance : ≥30000MΩ (C≤0.33μF) at 100VDC, 20°C for 60s  
 : ≥10000MΩ·μF (C>0.33μF) at 100VDC, 20°C for 60s
- \*Dissipation factor : ≤0.1% at 1kHz, 20°C
- \*Category temperature range : From -40°C to +110°C  
 (including temperature rise on unit surface)

QUANTITY of MINIMUM ORDER

Capacitance range (μF)	Quantity (pcs.)
0.1 ~ 0.15	1400
0.18	1300
0.22~ 0.27	1200
0.33	1100
0.39	1000

Reference

DESIGN	<i>M. Mochizuki</i>
CHECKED	<i>N. Kosuga</i>
APPROVAL	<i>K. Takemitsu</i>
ESTABLISHMENT	Nov. 22, 2012
TYPE NAME	ECWFD2W*** () 4
NAME	METALLIZED POLYPROPYLENE CAPACITOR
DRAWING NAME	PRODUCT DRAWING
DRAWING No.	B088J-J-E (1/2)

Film Capacitor Division  
 Capacitor Business Division  
 Panasonic Corporation

THIRD ANGLE PROJECTION

- Note 1. No more than 3 consecutive missing is permitted.  
 Note 2. A tape conjunction and a tape discrepancy specify as follows.

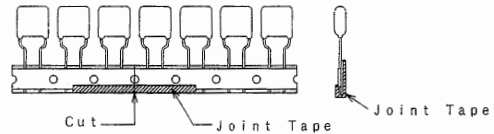

A tape sliding shall not exceed in an allowance of "P<sub>0</sub>" dimension.  
 A joint tape put on the back side of paper backing, and turn up the lower part to the front.

- Note 3. A tape trailer having at least 3 feed holes is required at the end of the tape.  
 Note 4. Marking on components may not be the same side.  
 Note 5. The tape adhesion is more than 3.92N(400gf)/25mm.

Packing specification

1. Case size (Ammo pack)

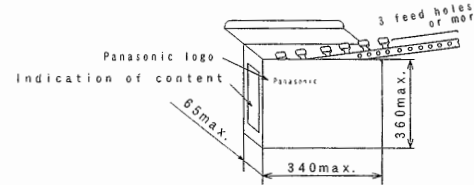

2. Packing quantity

Capacitance range (μF)	Quantity (pcs.)
0.1 ~ 0.15	1400
0.18	1300
0.22 ~ 0.27	1200
0.33	1100
0.39	1000

Handling notes

- 1) One package must be packed one product only.
- 2) The storage must be stacked 5 boxes or less.  
(Surface printed placing upward)  
(For prevention from displacement of capacitors and damage of lead crimping)
- 3) The packing box must be handled with care and never thrown out.

**Reference**

TYPE NAME	ECWFD2W*** () 4
DRAWING No.	B088J-J-E (2/2)

Film Capacitor Division  
 Capacitor Business Division  
 Panasonic Corporation

THIRD ANGLE PROJECTION

ITEM CODE	CAPACITANCE μF (*)	DIMENSIONS					VOLUME (mm <sup>3</sup> )
		L	T	H	H <sub>1</sub>	d	
ECWFD2W474 () 4	0.47 (474)	17.5	5.8	9.0	31.0	0.8	787
" 2W564 () 4	0.56 (564)	"	6.2	9.4	31.4	"	874
" 2W684 () 4	0.68 (684)	"	6.7	9.9	31.9	"	987
" 2W824 () 4	0.82 (824)	"	7.2	10.4	32.4	"	1116
" 2W105 () 4	1.0 (105)	"	7.8	11.0	33.0	"	1279
" 2W125 () 4	1.2 (125)	"	8.5	11.6	33.6	"	1457
" 2W155 () 4	1.5 (155)	"	9.3	12.5	34.5	"	1718
" 2W185 () 4	1.8 (185)	"	10.1	13.3	35.3	"	1975
" 2W225 () 4	2.2 (225)	"	11.1	14.3	36.3	"	2313

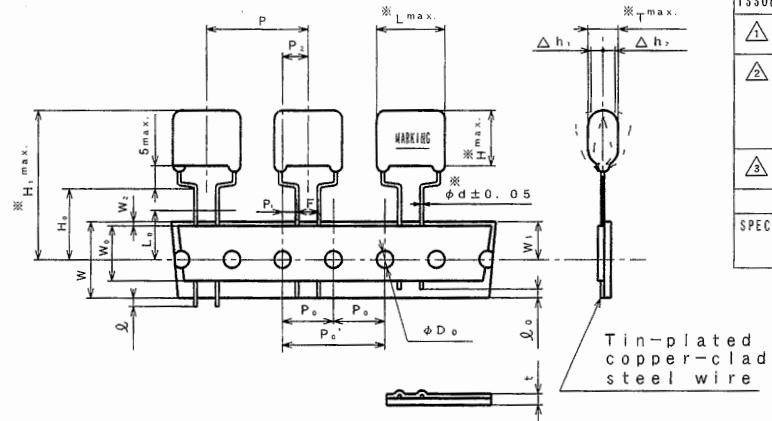

ALTERATION		
ISSUE	DESCRIPTION	DATE
△	Company name changed Correction	Apr. 1 2012
△	Change category temperature range (+105°C/+110°C) Derating of rated voltage (1.25%/°C=0.62%/°C)	Jul. 9 2012
△	Company name changed	Apr. 1 2013

SPECIFICATIONS No.

ITEM CODE NUMBER STRUCTURE

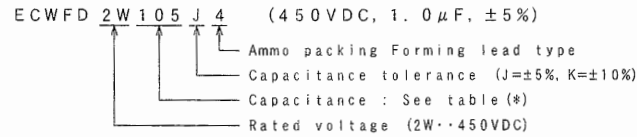

MARKING EXAMPLE

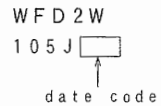

SYMBOL	ITEM	VALUE	TOLERANCE	REMARKS
P	Pitch of component	30.0	±1.0	Tilt of component and curvature of leads shall be included.
P <sub>0</sub>	Feed hole pitch	30.0	±0.2	
P <sub>1</sub>	Feed hole pitch	15.0	±0.2	
P <sub>2</sub>	Hole center to comp. center	7.5	±1.3	Tilt of component due to curvature of leads shall be included.
F	Lead-to-lead distance	7.5	+0.8 -0.2	
Δh <sub>1,2</sub>	Component alignment	0~2.0		Tilt of component due to curvature of leads shall be included.
W	Paper backing width	18.0	±0.5	
W <sub>0</sub>	Adhesive tape width	12.5	min.	The hold down tape shall not protrude beyond the carrier tape.
W <sub>1</sub>	Hole position	9.0	±0.5	
W <sub>2</sub>	Hold-down tape position	0~3.0		
H <sub>0</sub>	Lead-wire clinch height	16.0	+1.0	
Q	Lead wire protrusion	0	max.	
Q <sub>0</sub>	Lead wire depression	7.0	max.	
φD <sub>0</sub>	Feed hole diameter	4.0	±0.2	
t	Total tape thickness	0.7	±0.2	Total thickness including the hold down tape.
L <sub>0</sub>	Length of snapped lead	11.0	max.	

CONSTRUCTION

The capacitor is of non-inductive construction, wound with metallized polypropylene film dielectric.  
The capacitor is enclosed in non-combustible epoxy resin and has two leads.

MARKING

Marking comprises capacitance, capacitance tolerance, rated voltage and date code.

PROPERTIES

- \*Capacitance : See table at 1kHz.
- \*Capacitance tolerance : ±5% (J), ±10% (K) at 1kHz.
- \*Rated voltage : 450VDC
- △ (Derating of rated voltage by 0.62%/°C at more than 85°C)
- \*Withstand voltage (terminal-terminal) : 450VDCX150% for 60s
- \*Insulation resistance : ≥10000MΩ·μF at 100VDC, 20°C for 60s
- \*Dissipation factor : ≤0.1% at 1kHz, 20°C
- \*Category temperature range : △ From -40°C to +110°C (including temperature rise on unit surface)

QUANTITY of MINIMUM ORDER

Capacitance range (μF)	Quantity (pcs.)
0.47 ~ 0.56	500
0.68 ~ 1.0	400
1.2 ~ 1.8	300
2.2	200

Reference

DESIGN	M. Mochida	
CHECKED	M. Kosuga	
APPROVAL	K. Fukumoto	
ESTABLISHMENT	Mar. 19. 2012	
TYPE NAME	ECWFD2W*** () 4	
NAME	METALLIZED POLYPROPYLENE CAPACITOR	
DRAWING NAME	PRODUCT DRAWING	
DRAWING No.	B023J-J-E (1/2)	

Film Capacitor Division  
Capacitor Business Division  
Panasonic Corporation

THIRD ANGLE PROJECTION

- Note 1. No more than 2 consecutive missing is permitted.  
 Note 2. A tape conjunction and a tape discrepancy specify as follows.

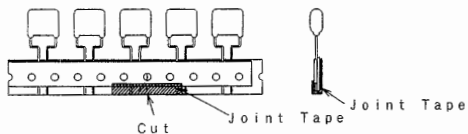

A tape sliding shall not exceed in an allowance of "P<sub>0</sub>" dimension.  
 A joint tape put on the back side of paper backing, and turn up the lower part to the front.

- Note 3. A tape trailer having at least 3 feed holes is required at the end of the tape.  
 Note 4. Marking on components may not be the same side.  
 Note 5. The tape adhesion is more than 3.92N (400gf) / 25mm.  
 Note 6. The lead clinch at the tape, shows as follows.

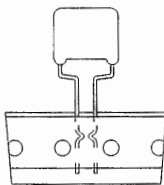

Packing specification

1. Case size (Ammo pack)

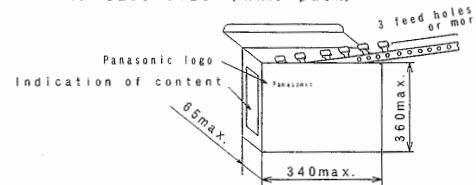

2. Packing quantity

Capacitance range (μF)	Quantity (pcs.)
0.47~0.56	500
0.68~1.0	400
1.2~1.8	300
2.2	200

Handling notes

- 1) One package must be packed one product only.
- 2) The storage must be stacked 5 boxes or less.  
 (Surface printed placing upward)  
 (For prevention from displacement of capacitors and damage of lead crimping)
- 3) The packing box must be handled with care and never thrown out.

**Reference**

TYPE NAME	ECWFD2W*** () 4
DRAWING No.	B023J-J-E (2/2)

Film Capacitor Division  
 Capacitor Business Division  
 Panasonic Corporation

ITEM CODE	CAPACITANCE μF (*)	DIMENSIONS					VOLUME (mm <sup>3</sup> )
		L	T	H	H <sub>1</sub>	d	
ECWFD2W474**	0.47 (474)	12.6	6.5	11.2	33.2	0.6	806
" 2W684**	0.68 (684)	"	7.7	12.4	34.2	"	1040
" 2W105**	1.0 (105)	"	9.2	13.9	35.9	"	1368

P4=±5% (J)  
Q4=±10% (K)

△  
△

MARKING EXAMPLE

WFD2W  
474J     
↑  
date code

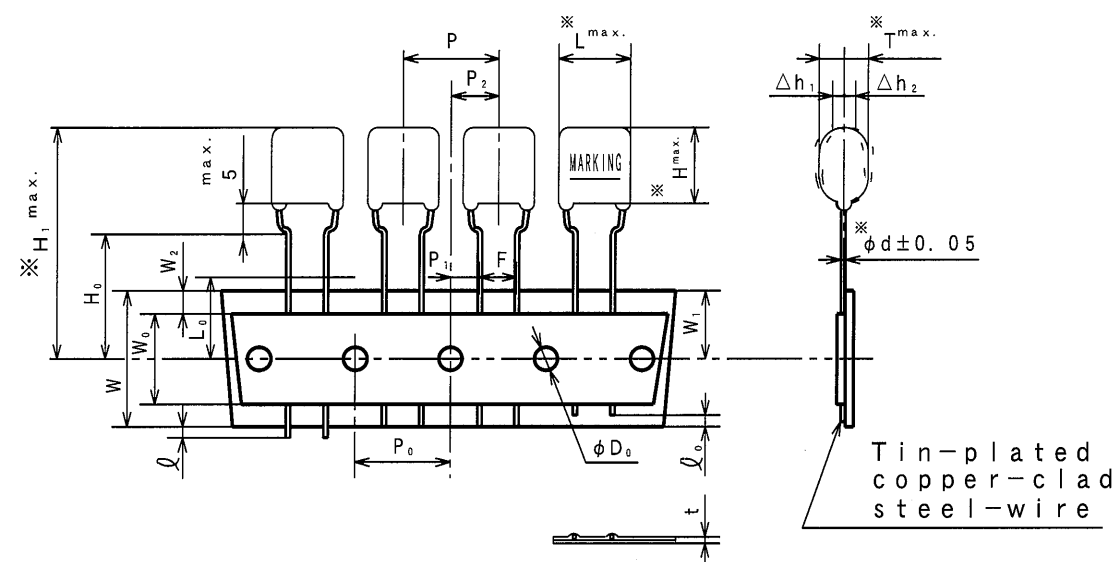

ALTERATION		
ISSUE	DESCRIPTION	DATE
△	Addition Capacitance (684, 105)	Oct. 10 2013
SPECIFICATIONS No.		

SYMBOL	ITEM	VALUE	TOLERANCE	REMARKS
P	Pitch of component	15.0	±1.0	Tilt of component and curvature of leads shall be included.
P <sub>0</sub>	Feed hole pitch	15.0	±0.2	
P <sub>1</sub>	Feed hole center to lead	3.75	±0.5	
P <sub>2</sub>	Hole center to comp. center	7.5	±1.3	Tilt of component due to curvature of leads shall be included.
F	Lead-to-lead distance	7.5	+0.8 -0.2	
Δh <sub>1,2</sub>	Component alignment	0~2.0		Tilt of component due to curvature of leads shall be included.
W	Paper backing width	18.0	±0.5	
W <sub>0</sub>	Adhesive tape width	12.5	min.	The hold down tape shall not protrude beyond the carrier tape.
W <sub>1</sub>	Hole position	9.0	±0.5	
W <sub>2</sub>	Hold-down tape position	0~3.0		
H <sub>0</sub>	Lead-wire clinch height	16.0	+1.0	
ℓ	Lead wire protrusion	0	max.	
ℓ <sub>0</sub>	Lead wire depression	7.0	max.	
φD <sub>0</sub>	Feed hole diameter	4.0	±0.2	
t	Total tape thickness	0.7	±0.2	Total thickness including the hold down tape.
L <sub>0</sub>	Length of snapped lead	11.0	max.	

CONSTRUCTION

The capacitor is of non-inductive construction, wound with metallized polypropylene film dielectric.

The capacitor is enclosed in non-combustible epoxy resin and has two leads.

MARKING

Marking comprises capacitance, capacitance tolerance, rated voltage and date code.

PROPERTIES

- \*Capacitance : See table at 1kHz.
- \*Capacitance tolerance : ±5% (J), ±10% (K) at 1kHz.
- \*Rated voltage : 450VDC  
(Derating of rated voltage by 0.62%/°C at more than 85°C)
- \*Withstand voltage (terminal-terminal) : 450VDC×150% for 60s
- \*Insulation resistance : ≥10000MΩ·μF at 100VDC, 20°C for 60s
- \*Dissipation factor : ≤0.1% at 1kHz, 20°C
- \*Category temperature range : From -40°C to +110°C  
(including temperature rise on unit surface)

QUANTITY of MINIMUM ORDER

Capacitance range (μF)	Quantity (pcs.)
0.47	900
0.68	700
1.0	600

△  
△

DESIGN	M. Mebada
CHECKED	M. Yamamoto
APPROVAL	K. Fukumitsu
ESTABLISHMENT	Jul. 19. 2013
TYPE NAME	ECWFD 2W***P4 ECWFD 2W***Q4
NAME	METALLIZED POLYPROPYLENE CAPACITOR
DRAWING NAME	PRODUCT DRAWING
DRAWING No.	B092J-J-E (1/2)

Film Capacitor Division  
Capacitor Business Division  
Panasonic Corporation

- Note 1. No more than 3 consecutive missing is permitted.  
 Note 2. A tape conjunction and a tape discrepancy specify as follows.

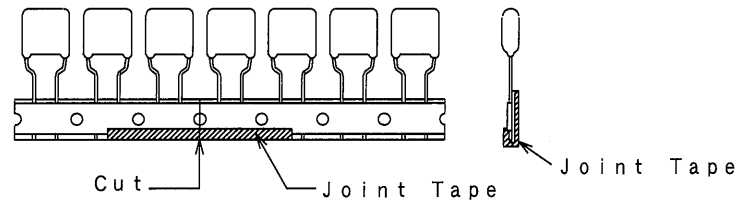

A tape sliding shall not exceed in an allowance of "P<sub>0</sub>" dimension.  
 A joint tape put on the back side of paper backing, and turn up the lower part to the front.

- Note 3. A tape trailer having at least 3 feed holes is required at the end of the tape.  
 Note 4. Marking on components may not be the same side.  
 Note 5. The tape adhesion is more than 3.92N (400gf) / 25mm.  
 Note 6. The lead clinch at the tape, shows as follows.

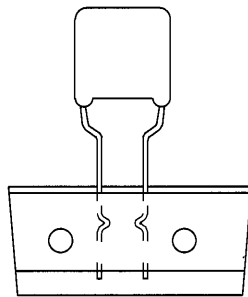

Packing specification

1. Case size (Ammo pack)

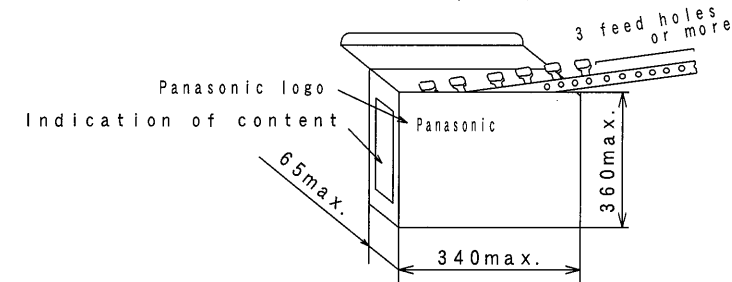

2. Packing quantity

	Capacitance range (μF)	Quantity (pcs.)
	0.47	900
△	0.68	700
△	1.0	600

Handling notes

- 1) One package must be packed one product only.
- 2) The storage must be stacked 5 boxes or less.  
 (Surface printed placing upward)  
 (For prevention from displacement of capacitors and damage of lead crimping)
- 3) The packing box must be handled with care and never thrown out.

TYPE NAME  
 ECWFD 2W\*\*\*P4  
 ECWFD 2W\*\*\*Q4

DRAWING No.  
 B092J-J-E (2/2)

Film Capacitor Division  
 Capacitor Business Division  
 Panasonic Corporation

ITEM CODE	CAPACITANCE		DIMENSIONS				
	$\mu F$	(*)	L	T	H	H <sub>1</sub>	d
ECWFD2W104 () 3	0.1	(104)	12.6	4.5	8.9	30.9	0.6
" 2W124 () 3	0.12	(124)	"	4.6	9.0	31.0	"
" 2W154 () 3	0.15	(154)	"	4.6	9.1	31.1	"
" 2W184 () 3	0.18	(184)	"	4.8	9.3	31.3	"
" 2W224 () 3	0.22	(224)	"	5.0	9.6	31.6	"
" 2W274 () 3	0.27	(274)	"	5.3	10.0	32.0	"
" 2W334 () 3	0.33	(334)	"	5.6	10.4	32.4	"
" 2W394 () 3	0.39	(394)	"	6.0	10.7	32.7	"

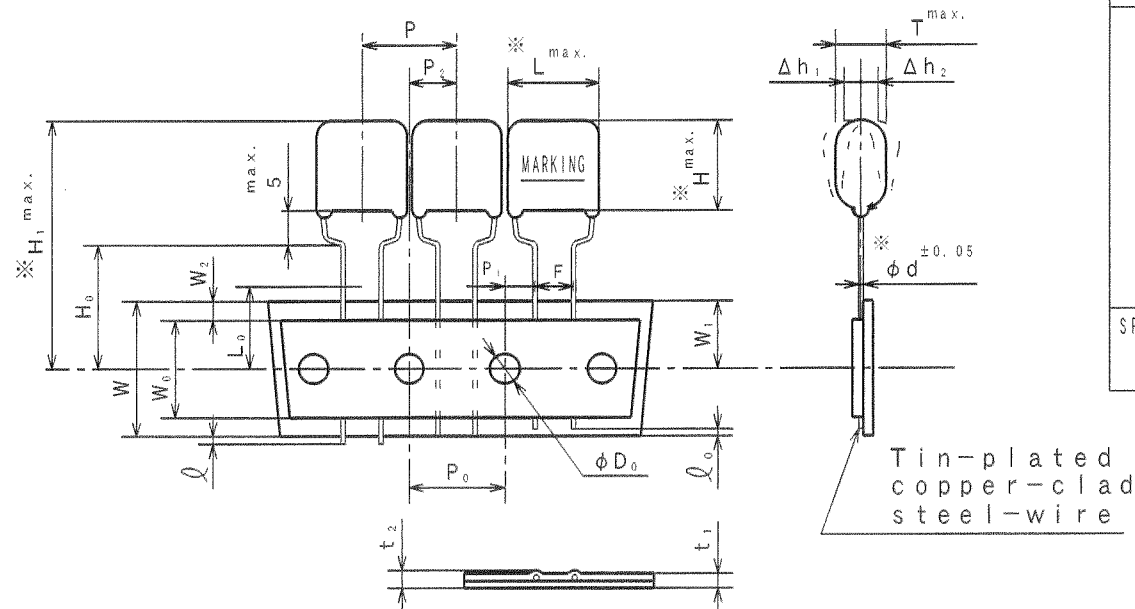

ALTERATION		
ISSUE	DESCRIPTION	DATE

SPECIFICATIONS No.

ITEM CODE NUMBER STRUCTURE

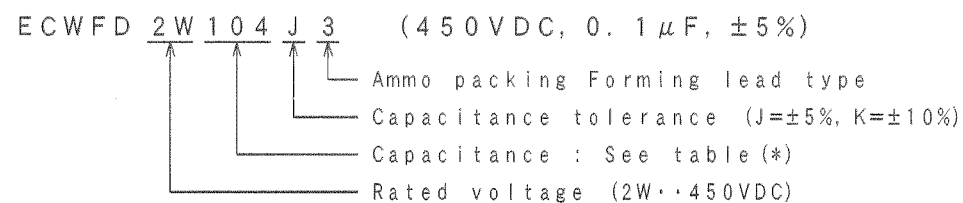

MARKING EXAMPLE

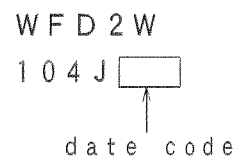

SYMBOL	ITEM	VALUE	TOLERANCE	REMARKS
P	Pitch of component	12.7	$\pm 1.0$	Tilt of component and curvature of leads shall be included.
P <sub>0</sub>	Feed hole pitch	12.7	$\pm 0.2$	
P <sub>1</sub>	Feed hole center to lead	3.85	$\pm 0.5$	
P <sub>2</sub>	Hole center to comp. center	6.35	$\pm 1.3$	Tilt of component due to curvature of leads shall be included.
F	Lead-to-lead distance	5.0	$\begin{matrix} +0.2 \\ -0.2 \end{matrix}$	
$\Delta h_{1,2}$	Component alignment	0~2.0		Tilt of component due to curvature of leads shall be included.
W	Paper backing width	18.0	$\pm 0.5$	
W <sub>0</sub>	Adhesive tape width	9.5	min.	The hold down tape shall not protrude beyond the carrier tape.
W <sub>1</sub>	Hole position	9.0	$\pm 0.5$	
W <sub>2</sub>	Hold-down tape position	0~3.0		
H <sub>0</sub>	Lead-wire clinch height	16.0	$+1.0$	
Q	Lead wire protrusion	0	max.	
Q <sub>0</sub>	Lead wire depression	7.0	max.	
$\phi D_0$	Feed hole diameter	4.0	$\pm 0.2$	
t <sub>1</sub>	Total tape thickness	0.7	$\pm 0.2$	Total thickness including the hold down tape.
t <sub>2</sub>	Total thickness	1.5	max.	
L <sub>0</sub>	Length of snapped lead	11.0	max.	

CONSTRUCTION

The capacitor is of non-inductive construction, wound with metallized polypropylene film dielectric.

The capacitor is enclosed in non-combustible epoxy resin and has two leads.

MARKING

Marking comprises capacitance, capacitance tolerance, rated voltage and date code.

PROPERTIES

- \*Capacitance : See table at 1kHz.
- \*Capacitance tolerance :  $\pm 5\%$  (J),  $\pm 10\%$  (K) at 1kHz.
- \*Rated voltage : 450VDC  
(Derating of rated voltage by 0.62%/°C at more than 85°C)
- \*Withstand voltage (terminal-terminal) : 450VDC $\times 150\%$  for 60s
- \*Insulation resistance :  $\geq 30000 M\Omega$  (C $\leq 0.33\mu F$ ) at 100VDC, 20°C for 60s  
:  $\geq 10000 M\Omega \cdot \mu F$  (C $> 0.33\mu F$ ) at 100VDC, 20°C for 60s
- \*Dissipation factor :  $\leq 0.1\%$  at 1kHz, 20°C
- \*Category temperature range : From -40°C to +110°C  
(including temperature rise on unit surface)

QUANTITY of MINIMUM ORDER

Capacitance range ( $\mu F$ )	Quantity (pcs.)
0.1 ~ 0.15	1500
0.18 ~ 0.22	1400
0.27	1300
0.33	1200
0.39	1100

DESIGN	M. Ikeda
CHECKED	M. Yamamoto
APPROVAL	K. Fukumitsu
ESTABLISHMENT	Sep. 26, 2013
TYPE NAME	
ECWFD2W*** () 3	
NAME METALLIZED POLYPROPYLENE CAPACITOR	
DRAWING NAME	
PRODUCT DRAWING	
DRAWING No.	
C014J-J-E (1/2)	

Film Capacitor Division  
Capacitor Business Division  
Panasonic Corporation

- Note 1. No more than 2 consecutive missing is permitted.  
 Note 2. A tape conjunction and a tape discrepancy specify as follows.

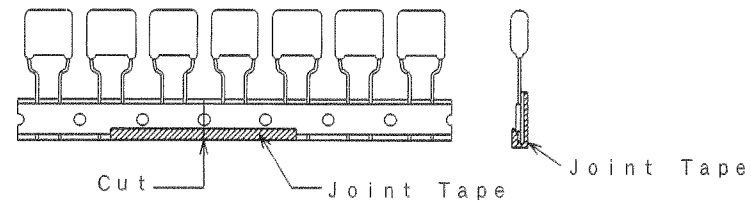

A tape sliding shall not exceed in an allowance of "P<sub>0</sub>" dimension.  
 A joint tape put on the back side of paper backing, and turn up the lower part to the front.

- Note 3. Marking on components may not be the same side.  
 Note 4. The tape adhesion is more than 3.92N (400gf) / 25mm.  
 Note 5. A tape trailer having at least 3 feed holes is required at the end of the tape.

Packing specification

1. Case size (Ammo pack)

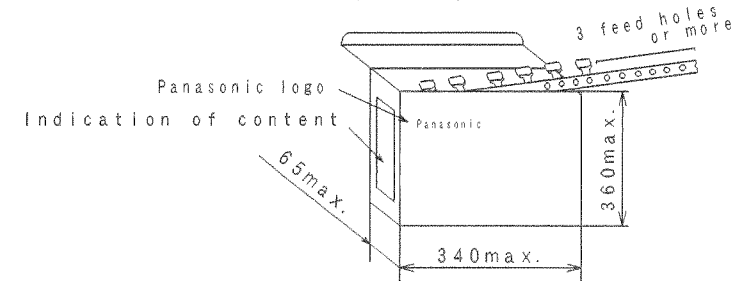

2. Packing quantity

Capacitance range (μF)	Quantity (pcs.)
0.1 ~ 0.15	1500
0.18 ~ 0.22	1400
0.27	1300
0.33	1200
0.39	1100

Handling notes

- 1) One package must be packed one product only.
- 2) The storage must be stacked 5 boxes or less.  
 (Surface printed placing upward)  
 (For prevention from displacement of capacitors and damage of lead crimping)
- 3) The packing box must be handled with care and never thrown out.

TYPE NAME  
 ECWFD2W\*\*\* () 3

DRAWING No.  
 C014J-J-E (2/2)

Film Capacitor Division  
 Capacitor Business Division  
 Panasonic Corporation



ITEM CODE	CAPACITANCE		DIMENSIONS					VOLUME (mm <sup>3</sup> )
	μF	(*)	L	T	H	H <sub>1</sub>	d	
ECWFD2W474**	0.47	(474)	12.6	6.5	11.2	33.2	0.6	806
" 2W684**	0.68	(684)	"	7.7	12.4	34.2	"	1040
" 2W105**	1.0	(105)	"	9.2	13.9	35.9	"	1368

P3=±5% (J)  
Q3=±10% (K)

△  
△

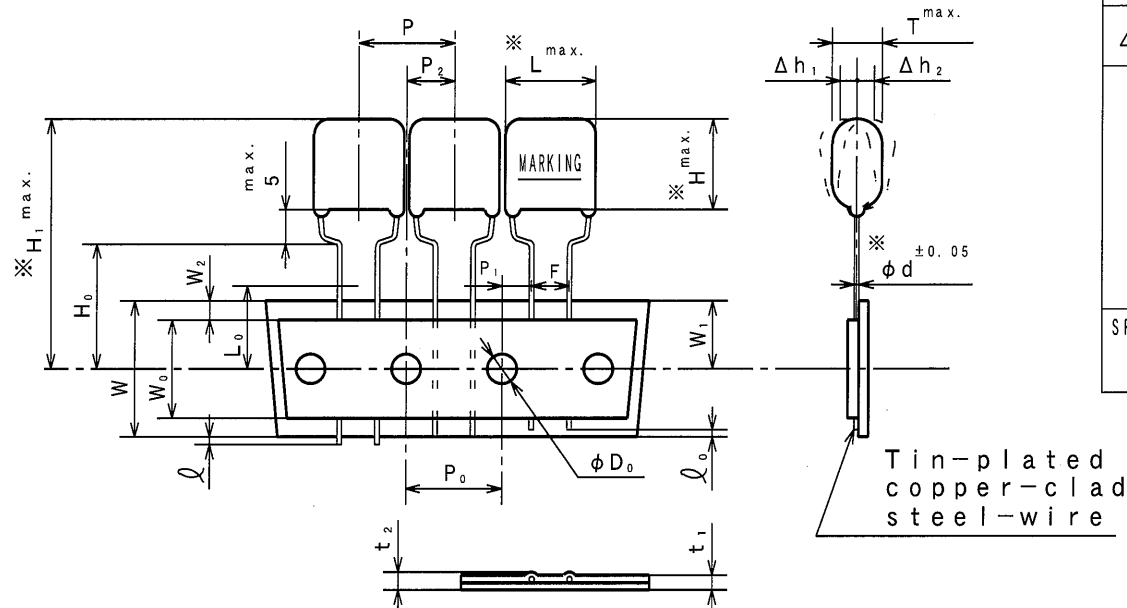

ALTERATION		
ISSUE	DESCRIPTION	DATE
△1	Addition Capacitance (684, 105)	Oct. 10 2013
SPECIFICATIONS No.		

MARKING EXAMPLE

WFD2W  
474J     
↑  
date code

SYMBOL	ITEM	VALUE	TOLERANCE	REMARKS
P	Pitch of component	12.7	±1.0	Tilt of component and curvature of leads shall be included.
P <sub>0</sub>	Feed hole pitch	12.7	±0.2	
P <sub>1</sub>	Feed hole center to lead	3.85	±0.5	
P <sub>2</sub>	Hole center to comp. center	6.35	±1.3	Tilt of component due to curvature of leads shall be included.
F	Lead-to-lead distance	5.0	+0.8 -0.2	
Δh <sub>1,2</sub>	Component alignment	0~2.0		Tilt of component due to curvature of leads shall be included.
W	Paper backing width	18.0	±0.5	
W <sub>0</sub>	Adhesive tape width	9.5	min.	The hold down tape shall not protrude beyond the carrier tape.
W <sub>1</sub>	Hole position	9.0	±0.5	
W <sub>2</sub>	Hold-down tape position	0~3.0		
H <sub>0</sub>	Lead-wire clinch height	16.0	+1.0 0	
Q	Lead wire protrusion	0	max.	
Q <sub>0</sub>	Lead wire depression	7.0	max.	
φD <sub>0</sub>	Feed hole diameter	4.0	±0.2	
t <sub>1</sub>	Total tape thickness	0.7	±0.2	Total thickness including the hold down tape.
t <sub>2</sub>	Total thickness	1.5	max.	
L <sub>0</sub>	Length of snapped lead	11.0	max.	

CONSTRUCTION

The capacitor is of non-inductive construction, wound with metallized polypropylene film dielectric.  
The capacitor is enclosed in non-combustible epoxy resin and has two leads.

MARKING

Marking comprises capacitance, capacitance tolerance, rated voltage and date code.

PROPERTIES

- \*Capacitance : See table at 1kHz.
- \*Capacitance tolerance : ±5% (J), ±10% (K) at 1kHz.
- \*Rated voltage : 450VDC  
(Derating of rated voltage by 0.62%/°C at more than 85°C)
- \*Withstand voltage (terminal-terminal) : 450VDC×150% for 60s
- \*Insulation resistance : ≥30000MΩ (C≤0.33μF) at 100VDC, 20°C for 60s  
: ≥10000MΩ·μF (C>0.33μF) at 100VDC, 20°C for 60s
- \*Dissipation factor : ≤0.1% at 1kHz, 20°C
- \*Category temperature range : From -40°C to +110°C  
(including temperature rise on unit surface)

QUANTITY of MINIMUM ORDER

Capacitance range (μF)	Quantity (pcs.)
0.47	900
0.68	700
1.0	600

△  
△

DESIGN	M. Mochida
CHECKED	M. Yanagimoto
APPROVAL	K. Fukumitsu
ESTABLISHMENT	Sep. 26, 2013
TYPE NAME	ECWFD 2W***P3 ECWFD 2W***Q3
NAME	METALLIZED POLYPROPYLENE CAPACITOR
DRAWING NAME	PRODUCT DRAWING
DRAWING No.	C019J-J-E (1/2)

Film Capacitor Division  
Capacitor Business Division  
Panasonic Corporation

- Note 1. No more than 2 consecutive missing is permitted.  
 Note 2. A tape conjunction and a tape discrepancy specify as follows.

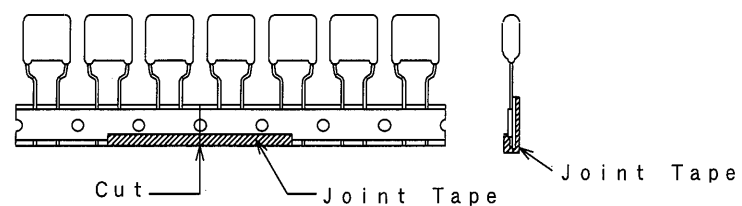

A tape sliding shall not exceed in an allowance of "P<sub>0</sub>" dimension.  
 A joint tape put on the back side of paper backing, and turn up the lower part to the front.

- Note 3. Marking on components may not be the same side.  
 Note 4. The tape adhesion is more than 3.92N (400gf)/25mm.  
 Note 5. A tape trailer having at least 3 feed holes is required at the end of the tape.

Packing specification

1. Case size (Ammo pack)

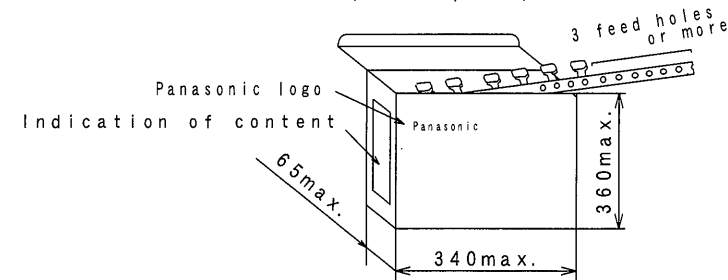

2. Packing quantity

Capacitance range (μF)	Quantity (pcs.)
0.47	1000
0.68	800
1.0	700

Handling notes

- 1) One package must be packed one product only.
- 2) The storage must be stacked 5 boxes or less.  
 (Surface printed placing upward)  
 (For prevention from displacement of capacitors and damage of lead crimping)
- 3) The packing box must be handled with care and never thrown out.

TYPE NAME ECWFD 2W***P3 ECWFD 2W***Q3
DRAWING No. C019J-J-E (2/2)

Film Capacitor Division  
 Capacitor Business Division  
 Panasonic Corporation