

SN75471 THRU SN75473 DUAL PERIPHERAL DRIVERS

SLRS024 – DECEMBER 1976 – REVISED MAY 1990

PERIPHERAL DRIVERS FOR HIGH-VOLTAGE HIGH-CURRENT DRIVER APPLICATIONS

- Characterized for Use to 300 mA
- High-Voltage Outputs
- No Output Latch-Up at 55 V (After Conducting 300 mA)
- Medium-Speed Switching
- Circuit Flexibility for Varied Applications and Choice of Logic Function
- TTL-Compatible Diode-Clamped Inputs
- Standard Supply Voltages
- Plastic DIP (P) With Copper Lead Frame Provides Cooler Operation and Improved Reliability

D OR P PACKAGE (TOP VIEW)

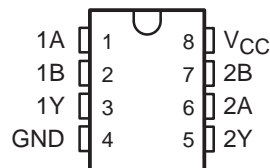

SUMMARY OF SERIES SN75471

DEVICE	LOGIC OF COMPLETE CIRCUIT	PACKAGES
SN75471	AND	D, P
SN75472	NAND	D, P
SN75473	OR	D, P

description

Series SN75471 dual peripheral drivers are functionally interchangeable with series SN75451B and series SN75461 peripheral drivers, but are designed for use in systems that require higher breakdown voltages than either of those series can provide at the expense of slightly slower switching speeds than series 75451B (limits are the same as series SN75461). Typical applications include high-speed logic buffers, power drivers, relay drivers, lamp drivers, MOS drivers, line drivers, and memory drivers.

The SN75471, SN75472, and SN75473 are dual peripheral AND, NAND, and OR drivers, respectively, (assuming positive logic), with the output of the logic gates internally connected to the bases of the npn output transistors.

Series SN75471 drivers are characterized for operation from 0°C to 70°C.

SN75471 THRU SN75473 DUAL PERIPHERAL DRIVERS

SLRS024 – DECEMBER 1976 – REVISED MAY 1990

absolute maximum ratings over operating free-air temperature range (unless otherwise noted)

Supply voltage, V_{CC} (see Note 1)	7 V
Input voltage, V_I	5.5 V
Inter-emitter voltage (see Note 2)	5.5 V
Off-state output voltage, V_O	70 V
Continuous collector or output current (see Note 3)	400 mA
Peak collector or output current ($t_w \leq 10$ ms, duty cycle $\leq 50\%$, see Note 3)	500 mA
Continuous total power dissipation	See Dissipation Rating Table
Operating free-air temperature range, T_A	0°C to 70°C
Storage temperature range, T_{stg}	-65°C to 150°C
Lead temperature 1,6 mm (1/16 inch) from case for 10 seconds	260°C

- NOTES: 1. Voltage values are with respect to the network GND, unless otherwise specified.
 2. This is the voltage between two emitters, A and B.
 3. Both halves of these dual circuits may conduct rated current simultaneously; however, power dissipation averaged over a short time interval must fall within the continuous dissipation rating.

DISSIPATION RATING TABLE

PACKAGE	$T_A \leq 25^\circ\text{C}$ POWER RATING	DERATING FACTOR ABOVE $T_A = 25^\circ\text{C}$	$T_A = 70^\circ\text{C}$ POWER RATING
D	725 mW	5.8 mW/°C	464 mW
P	1000 mW	8.0 mW/°C	640 mW

recommended operating conditions

	MIN	NOM	MAX	UNIT
Supply voltage, V_{CC}	4.75	5	5.25	V
High-level input voltage, V_{IH}	2			V
Low-level input voltage, V_{IL}			0.8	V
Operating free-air temperature, T_A	0		70	°C



SN75471 THRU SN75473 DUAL PERIPHERAL DRIVERS

SLRS024 – DECEMBER 1976 – REVISED MAY 1990

logic symbol†



† This symbol is in accordance with ANSI/IEEE Std 91-1984 and IEC Publication 617-12.

logic diagram (positive logic)

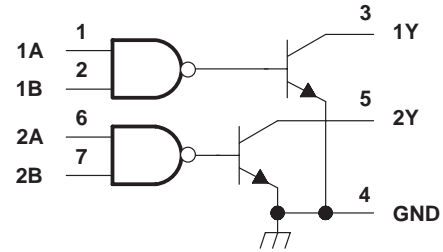

SN75471 FUNCTION TABLE
(each driver)

A	B	Y
L	L	L (on state)
L	H	L (on state)
H	L	L (on state)
H	H	H (off state)

positive logic:
 $Y = AB$ or $\bar{A} + \bar{B}$

SN75471 schematic (each driver)

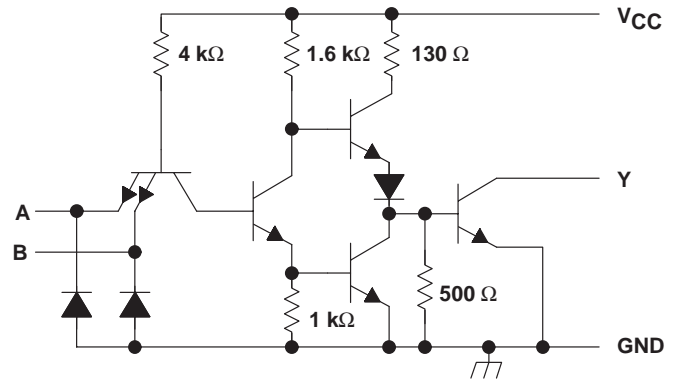

Resistor values shown are nominal.

electrical characteristics over recommended operating free-air temperature range

PARAMETER	TEST CONDITIONS	SN75471			UNIT
		MIN	TYP‡	MAX	
V_{IK} Input clamp voltage	$V_{CC} = 4.75$ V, $I_I = -12$ mA	-1.2	-1.5		V
I_{OH} High-level output current	$V_{CC} = 4.75$ V, $V_{IH} = 2$ V, $V_{OH} = 70$ V			100	μ A
V_{OL} Low-level output voltage	$V_{CC} = 4.75$ V, $V_{IL} = 0.8$ V, $I_{OL} = 100$ mA		0.25	0.4	V
	$V_{CC} = 4.75$ V, $V_{IL} = 0.8$ V, $I_{OL} = 300$ mA		0.5	0.7	
I_I Input current at maximum input voltage	$V_{CC} = 5.25$ V, $V_I = 5.5$ V			1	mA
I_{IH} High-level input current	$V_{CC} = 5.25$ V, $V_I = 2.4$ V			40	μ A
I_{IL} Low-level input current	$V_{CC} = 5.25$ V, $V_I = 0.4$ V		-1	-1.6	mA
I_{CCH} Supply current, outputs high	$V_{CC} = 5.25$ V, $V_I = 5$ V		7	11	mA
I_{CCL} Supply current, outputs low	$V_{CC} = 5.25$ V, $V_I = 0$		52	65	mA

‡ All typical values are at $V_{CC} = 5$ V, $T_A = 25^\circ\text{C}$.

switching characteristics, $V_{CC} = 5$ V, $T_A = 25^\circ\text{C}$

PARAMETER	TEST CONDITIONS	SN75471			UNIT
		MIN	TYP	MAX	
t_{PLH} Propagation delay time, low-to-high-level output	$I_O \approx 200$ mA, $C_L = 15$ pF, $R_L = 50$ Ω , See Figure 1		30	55	ns
t_{PHL} Propagation delay time, high-to-low-level output			25	40	
t_{TLH} Transition time, low-to-high-level output			8	20	
t_{THL} Transition time, high-to-low-level output			10	20	
V_{OH} High-level output voltage after switching	$V_S = 55$ V, $I_O \approx 300$ mA, See Figure 2	$V_S - 18$			mV

SN75471 THRU SN75473 DUAL PERIPHERAL DRIVERS

SLRS024 – DECEMBER 1976 – REVISED MAY 1990

logic symbol†



† This symbol is in accordance with ANSI/IEEE Std 91-1984 and IEC Publication 617-12.

logic diagram (positive logic)

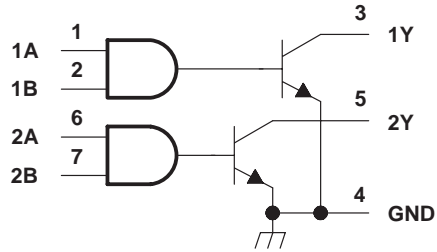

**SN75472 FUNCTION TABLE
(each driver)**

A	B	Y
L	L	H (off state)
L	H	H (off state)
H	L	H (off state)
H	H	L (on state)

positive logic:
 $Y = \overline{AB}$ or $\overline{A + B}$

SN75472 schematic (each driver)

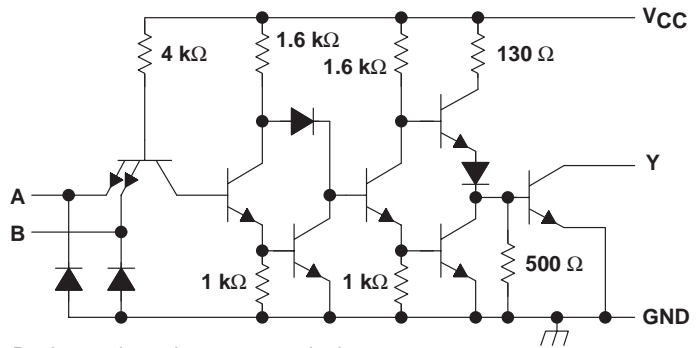

Resistor values shown are nominal.

electrical characteristics over recommended operating free-air temperature range

PARAMETER	TEST CONDITIONS	SN75472			UNIT	
		MIN	TYP‡	MAX		
V_{IK} Input clamp voltage	$V_{CC} = 4.75 \text{ V}$, $I_I = -12 \text{ mA}$	-1.2	-1.5		V	
I_{OH} High-level output current	$V_{CC} = 4.75 \text{ V}$, $V_{IH} = 2 \text{ V}$, $V_{OH} = 70 \text{ V}$			100	μA	
V_{OL} Low-level output voltage	$V_{CC} = 4.75 \text{ V}$, $V_{IL} = 0.8 \text{ V}$, $I_{OL} = 100 \text{ mA}$	0.25		0.4	V	
	$V_{CC} = 4.75 \text{ V}$, $V_{IL} = 0.8 \text{ V}$, $I_{OL} = 300 \text{ mA}$	0.5		0.7		
I_I Input current at maximum input voltage	$V_{CC} = 5.25 \text{ V}$, $V_I = 5.5 \text{ V}$			1	mA	
I_{IH} High-level input current	$V_{CC} = 5.25 \text{ V}$, $V_I = 2.4 \text{ V}$			40	μA	
I_{IL} Low-level input current	$V_{CC} = 5.25 \text{ V}$, $V_I = 0.4 \text{ V}$			-1	-1.6	mA
I_{CCH} Supply current, outputs high	$V_{CC} = 5.25 \text{ V}$, $V_I = 5 \text{ V}$			13	17	mA
I_{CCL} Supply current, outputs low	$V_{CC} = 5.25 \text{ V}$, $V_I = 0$			61	76	mA

‡ All typical values are at $V_{CC} = 5 \text{ V}$, $T_A = 25^\circ\text{C}$.

switching characteristics, $V_{CC} = 5 \text{ V}$, $T_A = 25^\circ\text{C}$

PARAMETER	TEST CONDITIONS	SN75472			UNIT
		MIN	TYP	MAX	
t_{PLH} Propagation delay time, low-to-high-level output	$I_O \approx 200 \text{ mA}$, $C_L = 15 \text{ pF}$, $R_L = 50 \Omega$, See Figure 1		45	65	ns
t_{PHL} Propagation delay time, high-to-low-level output			30	50	
t_{TLH} Transition time, low-to-high-level output			13	25	
t_{THL} Transition time, high-to-low-level output			10	20	
V_{OH} High-level output voltage after switching	$V_S = 55 \text{ V}$, See Figure 2	$I_O \approx 300 \text{ mA}$,	$V_S - 18$		mV

logic symbol†

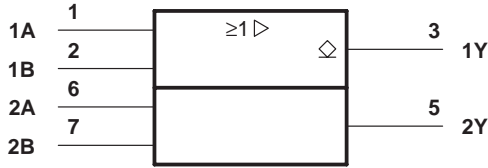

† This symbol is in accordance with ANSI/IEEE Std 91-1984 and IEC Publication 617-12.

logic diagram (positive logic)

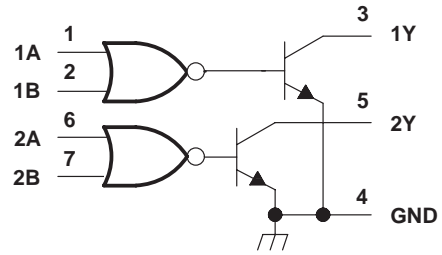

**FUNCTION TABLE
(each driver)**

A	B	Y
L	L	L (on state)
L	H	H (off state)
H	L	H (off state)
H	H	H (off state)

positive logic:
 $Y = A + B$ or $\overline{A} \overline{B}$

schematic (each driver)

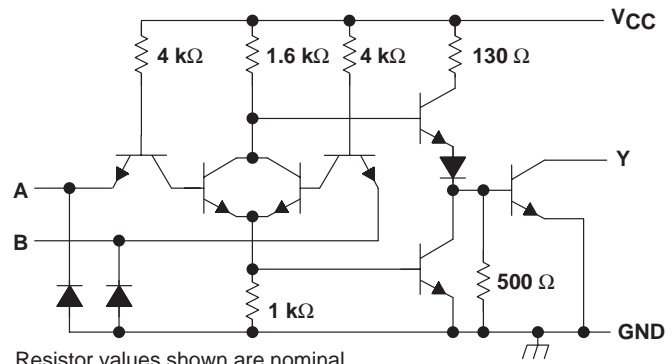

Resistor values shown are nominal.

electrical characteristics over recommended operating free-air temperature range

PARAMETER	TEST CONDITIONS	SN75473			UNIT
		MIN	TYP‡	MAX	
V_{IK} Input clamp voltage	$V_{CC} = 4.75 \text{ V}$, $I_I = -12 \text{ mA}$	-1.2	-1.5		V
I_{OH} High-level output current	$V_{CC} = 4.75 \text{ V}$, $V_{IH} = 2 \text{ V}$, $V_{OH} = 70 \text{ V}$			100	μA
V_{OL} Low-level output voltage	$V_{CC} = 4.75 \text{ V}$, $V_{IL} = 0.8 \text{ V}$, $I_{OL} = 100 \text{ mA}$	0.25	0.4		V
	$V_{CC} = 4.75 \text{ V}$, $V_{IL} = 0.8 \text{ V}$, $I_{OL} = 300 \text{ mA}$	0.5	0.7		
I_I Input current at maximum input voltage	$V_{CC} = 5.25 \text{ V}$, $V_I = 5.5 \text{ V}$			1	mA
I_{IH} High-level input current	$V_{CC} = 5.25 \text{ V}$, $V_I = 2.4 \text{ V}$			40	μA
I_{IL} Low-level input current	$V_{CC} = 5.25 \text{ V}$, $V_I = 0.4 \text{ V}$	-1	-1.6		mA
I_{CCH} Supply current, outputs high	$V_{CC} = 5.25 \text{ V}$, $V_I = 5 \text{ V}$	8	11		mA
I_{CCL} Supply current, outputs low	$V_{CC} = 5.25 \text{ V}$, $V_I = 0$	58	76		mA

‡ All typical values are at $V_{CC} = 5 \text{ V}$, $T_A = 25^\circ\text{C}$.

switching characteristics, $V_{CC} = 5 \text{ V}$, $T_A = 25^\circ\text{C}$

PARAMETER	TEST CONDITIONS	SN75473			UNIT
		MIN	TYP	MAX	
t_{PLH} Propagation delay time, low-to-high-level output	$I_O \approx 200 \text{ mA}$, $C_L = 15 \text{ pF}$, $R_L = 50 \Omega$, See Figure 1		30	55	ns
t_{PHL} Propagation delay time, high-to-low-level output			25	40	
t_{TLH} Transition time, low-to-high-level output			8	25	
t_{THL} Transition time, high-to-low-level output			10	25	
V_{OH} High-level output voltage after switching	$V_S = 55 \text{ V}$, See Figure 2	$I_O \approx 300 \text{ mA}$,	$V_S - 18$		mV

SN75471 THRU SN75473 DUAL PERIPHERAL DRIVERS

SLRS024 – DECEMBER 1976 – REVISED MAY 1990

PARAMETER MEASUREMENT INFORMATION

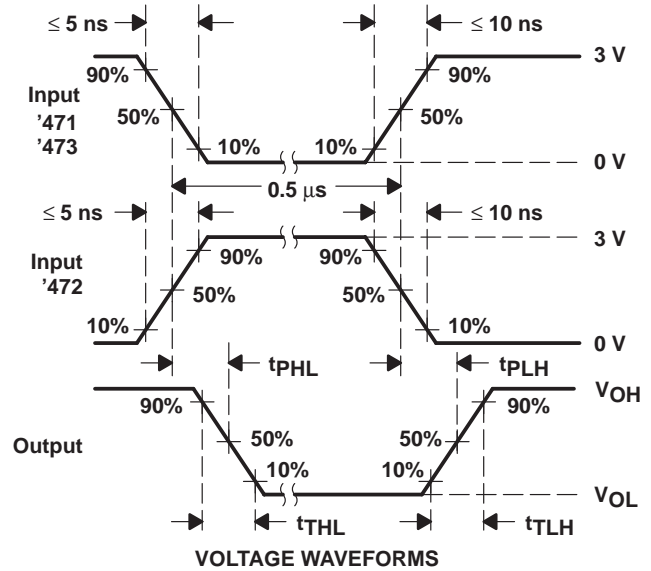
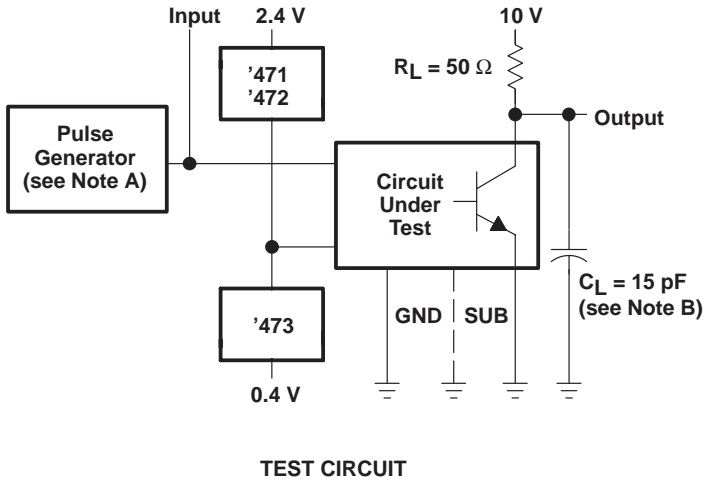

- NOTES: A. The pulse generator has the following characteristics: PRR \leq 1 MHz, $Z_O \approx 50 \Omega$.
 B. C_L includes probe and jig capacitance.

Figure 1. Switching Times

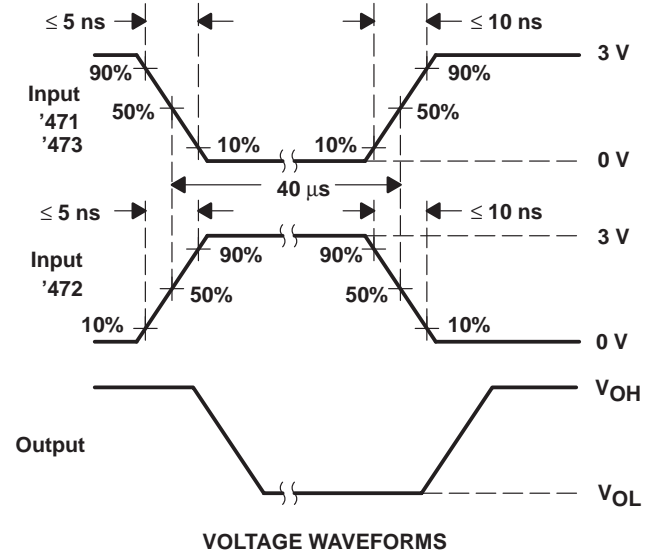
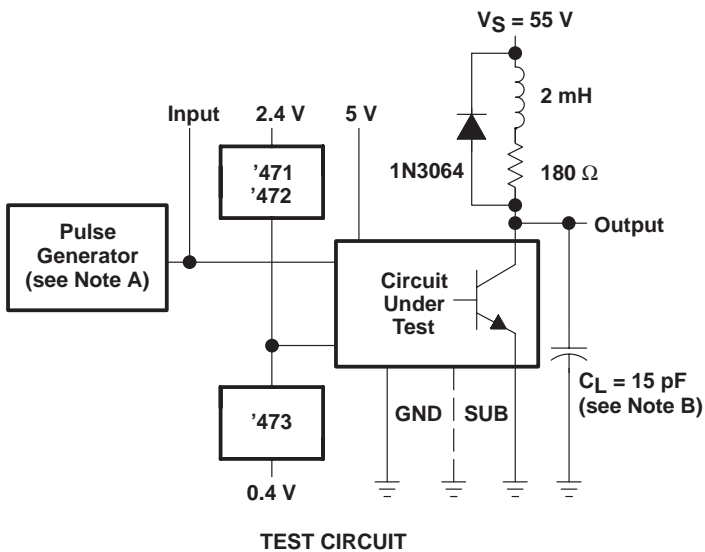

- NOTES: A. The pulse generator has the following characteristics: PRR \leq 12.5 kHz, $Z_O \approx 50 \Omega$.
 B. C_L includes probe and jig capacitance.

Figure 2. Latch-Up Test

PACKAGING INFORMATION

Orderable Device	Status (1)	Package Type	Package Drawing	Pins	Package Qty	Eco Plan (2)	Lead/Ball Finish (6)	MSL Peak Temp (3)	Op Temp (°C)	Device Marking (4/5)	Samples
SN75471D	ACTIVE	SOIC	D	8	75	Green (RoHS & no Sb/Br)	CU NIPDAU	Level-1-260C-UNLIM	0 to 70	75471	Samples
SN75471DR	ACTIVE	SOIC	D	8	2500	Green (RoHS & no Sb/Br)	CU NIPDAU	Level-1-260C-UNLIM	0 to 70	75471	Samples
SN75471P	ACTIVE	PDIP	P	8	50	Pb-Free (RoHS)	CU NIPDAU	N / A for Pkg Type	0 to 70	SN75471P	Samples
SN75472D	ACTIVE	SOIC	D	8	75	Green (RoHS & no Sb/Br)	CU NIPDAU	Level-1-260C-UNLIM	0 to 70	75472	Samples
SN75472DE4	ACTIVE	SOIC	D	8	75	Green (RoHS & no Sb/Br)	CU NIPDAU	Level-1-260C-UNLIM	0 to 70	75472	Samples
SN75472DG4	ACTIVE	SOIC	D	8	75	Green (RoHS & no Sb/Br)	CU NIPDAU	Level-1-260C-UNLIM	0 to 70	75472	Samples
SN75472P	ACTIVE	PDIP	P	8	50	Pb-Free (RoHS)	CU NIPDAU	N / A for Pkg Type	0 to 70	SN75472P	Samples
SN75472PE4	ACTIVE	PDIP	P	8	50	Pb-Free (RoHS)	CU NIPDAU	N / A for Pkg Type	0 to 70	SN75472P	Samples

(1) The marketing status values are defined as follows:

ACTIVE: Product device recommended for new designs.

LIFEBUY: TI has announced that the device will be discontinued, and a lifetime-buy period is in effect.

NRND: Not recommended for new designs. Device is in production to support existing customers, but TI does not recommend using this part in a new design.

PREVIEW: Device has been announced but is not in production. Samples may or may not be available.

OBSOLETE: TI has discontinued the production of the device.

(2) Eco Plan - The planned eco-friendly classification: Pb-Free (RoHS), Pb-Free (RoHS Exempt), or Green (RoHS & no Sb/Br) - please check <http://www.ti.com/productcontent> for the latest availability information and additional product content details.

TBD: The Pb-Free/Green conversion plan has not been defined.

Pb-Free (RoHS): TI's terms "Lead-Free" or "Pb-Free" mean semiconductor products that are compatible with the current RoHS requirements for all 6 substances, including the requirement that lead not exceed 0.1% by weight in homogeneous materials. Where designed to be soldered at high temperatures, TI Pb-Free products are suitable for use in specified lead-free processes.

Pb-Free (RoHS Exempt): This component has a RoHS exemption for either 1) lead-based flip-chip solder bumps used between the die and package, or 2) lead-based die adhesive used between the die and leadframe. The component is otherwise considered Pb-Free (RoHS compatible) as defined above.

Green (RoHS & no Sb/Br): TI defines "Green" to mean Pb-Free (RoHS compatible), and free of Bromine (Br) and Antimony (Sb) based flame retardants (Br or Sb do not exceed 0.1% by weight in homogeneous material)

(3) MSL, Peak Temp. - The Moisture Sensitivity Level rating according to the JEDEC industry standard classifications, and peak solder temperature.

(4) There may be additional marking, which relates to the logo, the lot trace code information, or the environmental category on the device.

(5) Multiple Device Markings will be inside parentheses. Only one Device Marking contained in parentheses and separated by a "~" will appear on a device. If a line is indented then it is a continuation of the previous line and the two combined represent the entire Device Marking for that device.

(6) Lead/Ball Finish - Orderable Devices may have multiple material finish options. Finish options are separated by a vertical ruled line. Lead/Ball Finish values may wrap to two lines if the finish value exceeds the maximum column width.

Important Information and Disclaimer:The information provided on this page represents TI's knowledge and belief as of the date that it is provided. TI bases its knowledge and belief on information provided by third parties, and makes no representation or warranty as to the accuracy of such information. Efforts are underway to better integrate information from third parties. TI has taken and continues to take reasonable steps to provide representative and accurate information but may not have conducted destructive testing or chemical analysis on incoming materials and chemicals. TI and TI suppliers consider certain information to be proprietary, and thus CAS numbers and other limited information may not be available for release.

In no event shall TI's liability arising out of such information exceed the total purchase price of the TI part(s) at issue in this document sold by TI to Customer on an annual basis.

TAPE AND REEL INFORMATION



QUADRANT ASSIGNMENTS FOR PIN 1 ORIENTATION IN TAPE



*All dimensions are nominal

Device	Package Type	Package Drawing	Pins	SPQ	Reel Diameter (mm)	Reel Width W1 (mm)	A0 (mm)	B0 (mm)	K0 (mm)	P1 (mm)	W (mm)	Pin1 Quadrant
SN75471DR	SOIC	D	8	2500	330.0	12.4	6.4	5.2	2.1	8.0	12.0	Q1

TAPE AND REEL BOX DIMENSIONS



*All dimensions are nominal

Device	Package Type	Package Drawing	Pins	SPQ	Length (mm)	Width (mm)	Height (mm)
SN75471DR	SOIC	D	8	2500	340.5	338.1	20.6

D (R-PDSO-G8)

PLASTIC SMALL OUTLINE



4040047-3/M 06/11

D (R-PDSO-G8)

PLASTIC SMALL OUTLINE



- NOTES:
- All linear dimensions are in millimeters.
 - This drawing is subject to change without notice.
 - Publication IPC-7351 is recommended for alternate designs.
 - Laser cutting apertures with trapezoidal walls and also rounding corners will offer better paste release. Customers should contact their board assembly site for stencil design recommendations. Refer to IPC-7525 for other stencil recommendations.
 - Customers should contact their board fabrication site for solder mask tolerances between and around signal pads.

P (R-PDIP-T8)

PLASTIC DUAL-IN-LINE PACKAGE



- NOTES:
- A. All linear dimensions are in inches (millimeters).
 - B. This drawing is subject to change without notice.
 - C. Falls within JEDEC MS-001 variation BA.

IMPORTANT NOTICE

Texas Instruments Incorporated (TI) reserves the right to make corrections, enhancements, improvements and other changes to its semiconductor products and services per JESD46, latest issue, and to discontinue any product or service per JESD48, latest issue. Buyers should obtain the latest relevant information before placing orders and should verify that such information is current and complete.

TI's published terms of sale for semiconductor products (<http://www.ti.com/sc/docs/stdterms.htm>) apply to the sale of packaged integrated circuit products that TI has qualified and released to market. Additional terms may apply to the use or sale of other types of TI products and services.

Reproduction of significant portions of TI information in TI data sheets is permissible only if reproduction is without alteration and is accompanied by all associated warranties, conditions, limitations, and notices. TI is not responsible or liable for such reproduced documentation. Information of third parties may be subject to additional restrictions. Resale of TI products or services with statements different from or beyond the parameters stated by TI for that product or service voids all express and any implied warranties for the associated TI product or service and is an unfair and deceptive business practice. TI is not responsible or liable for any such statements.

Buyers and others who are developing systems that incorporate TI products (collectively, "Designers") understand and agree that Designers remain responsible for using their independent analysis, evaluation and judgment in designing their applications and that Designers have full and exclusive responsibility to assure the safety of Designers' applications and compliance of their applications (and of all TI products used in or for Designers' applications) with all applicable regulations, laws and other applicable requirements. Designer represents that, with respect to their applications, Designer has all the necessary expertise to create and implement safeguards that (1) anticipate dangerous consequences of failures, (2) monitor failures and their consequences, and (3) lessen the likelihood of failures that might cause harm and take appropriate actions. Designer agrees that prior to using or distributing any applications that include TI products, Designer will thoroughly test such applications and the functionality of such TI products as used in such applications.

TI's provision of technical, application or other design advice, quality characterization, reliability data or other services or information, including, but not limited to, reference designs and materials relating to evaluation modules, (collectively, "TI Resources") are intended to assist designers who are developing applications that incorporate TI products; by downloading, accessing or using TI Resources in any way, Designer (individually or, if Designer is acting on behalf of a company, Designer's company) agrees to use any particular TI Resource solely for this purpose and subject to the terms of this Notice.

TI's provision of TI Resources does not expand or otherwise alter TI's applicable published warranties or warranty disclaimers for TI products, and no additional obligations or liabilities arise from TI providing such TI Resources. TI reserves the right to make corrections, enhancements, improvements and other changes to its TI Resources. TI has not conducted any testing other than that specifically described in the published documentation for a particular TI Resource.

Designer is authorized to use, copy and modify any individual TI Resource only in connection with the development of applications that include the TI product(s) identified in such TI Resource. NO OTHER LICENSE, EXPRESS OR IMPLIED, BY ESTOPPEL OR OTHERWISE TO ANY OTHER TI INTELLECTUAL PROPERTY RIGHT, AND NO LICENSE TO ANY TECHNOLOGY OR INTELLECTUAL PROPERTY RIGHT OF TI OR ANY THIRD PARTY IS GRANTED HEREIN, including but not limited to any patent right, copyright, mask work right, or other intellectual property right relating to any combination, machine, or process in which TI products or services are used. Information regarding or referencing third-party products or services does not constitute a license to use such products or services, or a warranty or endorsement thereof. Use of TI Resources may require a license from a third party under the patents or other intellectual property of the third party, or a license from TI under the patents or other intellectual property of TI.

TI RESOURCES ARE PROVIDED "AS IS" AND WITH ALL FAULTS. TI DISCLAIMS ALL OTHER WARRANTIES OR REPRESENTATIONS, EXPRESS OR IMPLIED, REGARDING RESOURCES OR USE THEREOF, INCLUDING BUT NOT LIMITED TO ACCURACY OR COMPLETENESS, TITLE, ANY EPIDEMIC FAILURE WARRANTY AND ANY IMPLIED WARRANTIES OF MERCHANTABILITY, FITNESS FOR A PARTICULAR PURPOSE, AND NON-INFRINGEMENT OF ANY THIRD PARTY INTELLECTUAL PROPERTY RIGHTS. TI SHALL NOT BE LIABLE FOR AND SHALL NOT DEFEND OR INDEMNIFY DESIGNER AGAINST ANY CLAIM, INCLUDING BUT NOT LIMITED TO ANY INFRINGEMENT CLAIM THAT RELATES TO OR IS BASED ON ANY COMBINATION OF PRODUCTS EVEN IF DESCRIBED IN TI RESOURCES OR OTHERWISE. IN NO EVENT SHALL TI BE LIABLE FOR ANY ACTUAL, DIRECT, SPECIAL, COLLATERAL, INDIRECT, PUNITIVE, INCIDENTAL, CONSEQUENTIAL OR EXEMPLARY DAMAGES IN CONNECTION WITH OR ARISING OUT OF TI RESOURCES OR USE THEREOF, AND REGARDLESS OF WHETHER TI HAS BEEN ADVISED OF THE POSSIBILITY OF SUCH DAMAGES.

Unless TI has explicitly designated an individual product as meeting the requirements of a particular industry standard (e.g., ISO/TS 16949 and ISO 26262), TI is not responsible for any failure to meet such industry standard requirements.

Where TI specifically promotes products as facilitating functional safety or as compliant with industry functional safety standards, such products are intended to help enable customers to design and create their own applications that meet applicable functional safety standards and requirements. Using products in an application does not by itself establish any safety features in the application. Designers must ensure compliance with safety-related requirements and standards applicable to their applications. Designer may not use any TI products in life-critical medical equipment unless authorized officers of the parties have executed a special contract specifically governing such use. Life-critical medical equipment is medical equipment where failure of such equipment would cause serious bodily injury or death (e.g., life support, pacemakers, defibrillators, heart pumps, neurostimulators, and implantables). Such equipment includes, without limitation, all medical devices identified by the U.S. Food and Drug Administration as Class III devices and equivalent classifications outside the U.S.

TI may expressly designate certain products as completing a particular qualification (e.g., Q100, Military Grade, or Enhanced Product). Designers agree that it has the necessary expertise to select the product with the appropriate qualification designation for their applications and that proper product selection is at Designers' own risk. Designers are solely responsible for compliance with all legal and regulatory requirements in connection with such selection.

Designer will fully indemnify TI and its representatives against any damages, costs, losses, and/or liabilities arising out of Designer's non-compliance with the terms and provisions of this Notice.