



KSZ8041NL/RNL

10BASE-T/100BASE-TX Physical Layer Transceiver

Highlights

- Single-Chip Ethernet Physical Layer Transceiver (PHY)
- HP Auto-MDIX Support

Target Applications

- Printer
- LOM
- Game Console
- IPTV
- IP Phone
- IP Set-Top Box

Key Benefits

- Single-Chip 10BASE-T/100BASE-TX Physical Layer Solution
- Fully Compliant To IEEE 802.3u Standard
- Low Power CMOS Design, Power Consumption Of <180 mW
- HP Auto MDI/MDI-X For Reliable Detection and Correction for Straight-Through and Crossover Cables with Disable and Enable Option
- Robust Operation Over Standard Cables
- Power Down and Power Saving Modes
- MII Interface Support (KSZ8041NL Only)
- RMII Interface Support with External 50 MHz System Clock (KSZ8041NL Only)
- RMII Interface Support With 25 MHz Crystal/ Clock Input and 50 MHz Reference Clock Output to MAC (KSZ8041RNL Only)
- MIIM (MDC/MDIO) Management Bus to 6.25 MHz for Rapid PHY Register Configuration
- Interrupt Pin Option
- Programmable LED Outputs for Link, Activity and Speed
- ESD Rating (6 kV)
- Single Power Supply (3.3V)
- Built-in 1.8V Regulator for Core
- Available In 32-pin 5 mm × 5 mm QFN Package

TO OUR VALUED CUSTOMERS

It is our intention to provide our valued customers with the best documentation possible to ensure successful use of your Microchip products. To this end, we will continue to improve our publications to better suit your needs. Our publications will be refined and enhanced as new volumes and updates are introduced.

If you have any questions or comments regarding this publication, please contact the Marketing Communications Department via E-mail at docerrors@microchip.com. We welcome your feedback.

Most Current Data Sheet

To obtain the most up-to-date version of this data sheet, please register at our Worldwide Web site at:

<http://www.microchip.com>

You can determine the version of a data sheet by examining its literature number found on the bottom outside corner of any page. The last character of the literature number is the version number, (e.g., DS30000000A is version A of document DS30000000).

Errata

An errata sheet, describing minor operational differences from the data sheet and recommended workarounds, may exist for current devices. As device/documentation issues become known to us, we will publish an errata sheet. The errata will specify the revision of silicon and revision of document to which it applies.

To determine if an errata sheet exists for a particular device, please check with one of the following:

- Microchip's Worldwide Web site; <http://www.microchip.com>
- Your local Microchip sales office (see last page)

When contacting a sales office, please specify which device, revision of silicon and data sheet (include -literature number) you are using.

Customer Notification System

Register on our web site at www.microchip.com to receive the most current information on all of our products.

Table of Contents

1.0 General Description	4
2.0 Pin Description and Configuration	6
3.0 Functional Description	17
4.0 Registers	29
5.0 Operational Characteristics	38
6.0 Electrical Characteristics	39
7.0 Timing Diagrams	40
8.0 Selection of Isolation Transformer	50
9.0 Selection of Reference Crystal	51
10.0 Package Outline & Recommended Land Pattern	52
Appendix A: Data Sheet Revision History	53
The Microchip Web Site	54
Customer Change Notification Service	54
Customer Support	54
Product Identification System	55

KSZ8041NL/RNL

1.0 GENERAL DESCRIPTION

The KSZ8041NL is a single supply 10BASE-T/100BASE-TX physical layer transceiver, which provides MII/RMII interfaces to transmit and receive data. A unique mixed signal design extends signaling distance while reducing power consumption.

HP Auto MDI/MDI-X provides the most robust solution for eliminating the need to differentiate between crossover and straight-through cables.

The KSZ8041NL represents a new level of features and performance and is an ideal choice of physical layer transceiver for 10BASE-T/100BASE-TX applications.

The KSZ8041RNL is an enhanced RMII version of the KSZ8041NL that does not require a 50 MHz system clock. It uses a 25 MHz crystal for its input reference clock and outputs a 50 MHz RMII reference clock to the MAC.

The KSZ8041NL and KSZ8041RNL are available in 32-pin, lead-free QFN packages (see [Product Identification System](#)).

FIGURE 1-1: KSZ8041NL FUNCTIONAL DIAGRAM

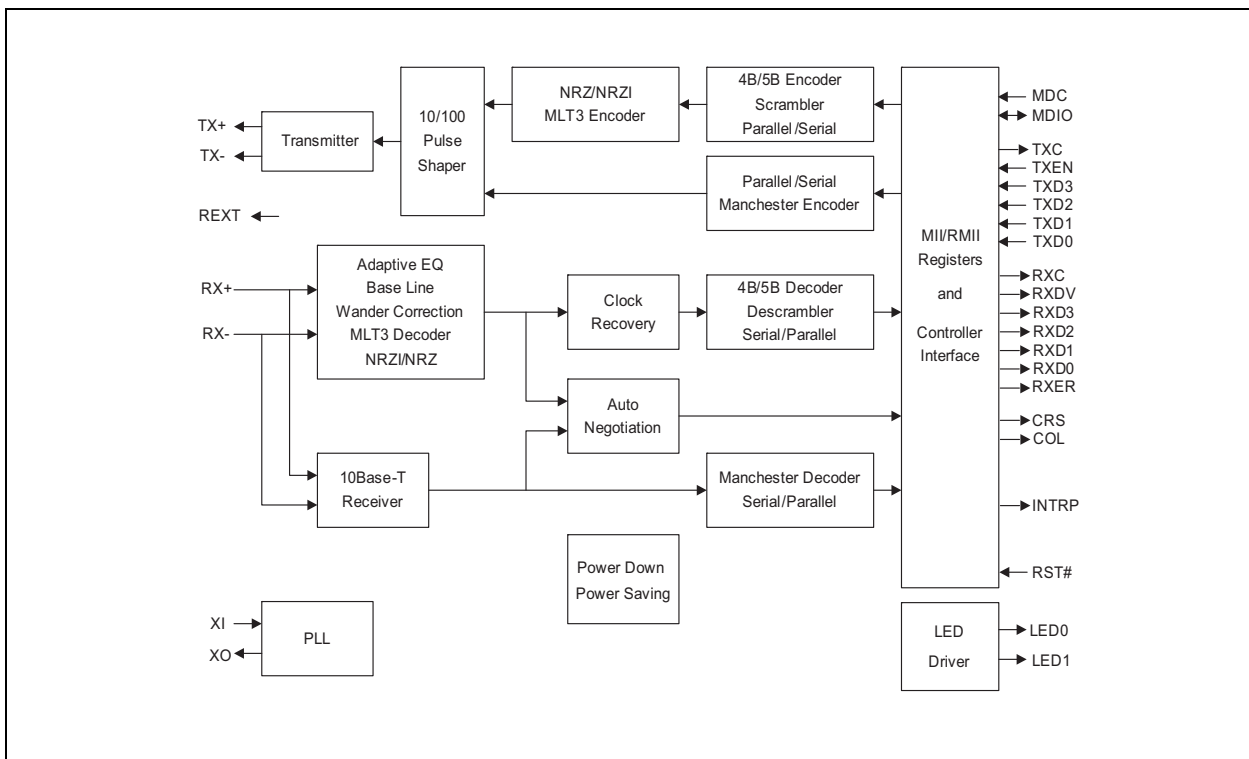
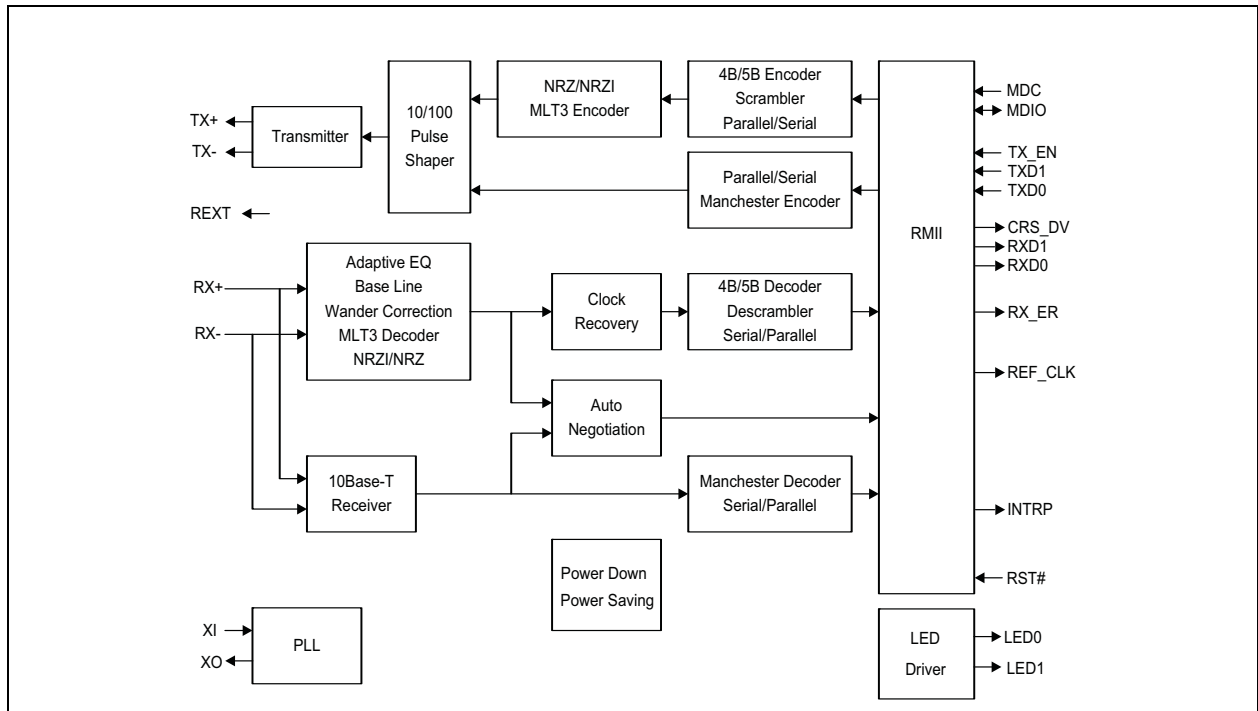

FIGURE 1-2: KSZ8041RNL FUNCTIONAL DIAGRAM



KSZ8041NL/RNL

2.0 PIN DESCRIPTION AND CONFIGURATION

2.1 KSZ8041NL Pin Description and Configuration

FIGURE 2-1: KSZ8041NL 32-QFN PIN ASSIGNMENT (TOP VIEW)

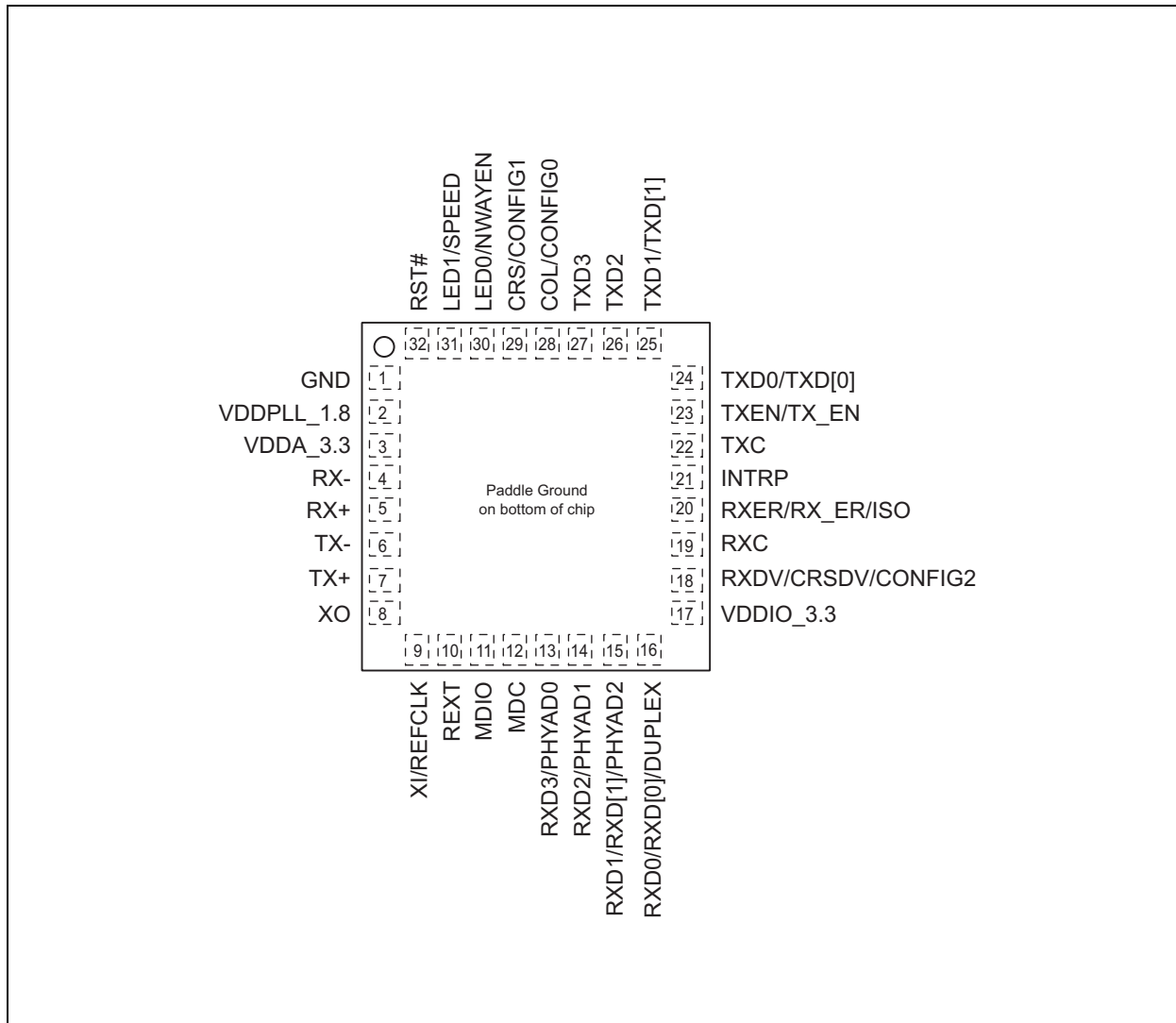

TABLE 2-1: KSZ8041NL PIN DESCRIPTION

Pin Number	Symbol	Buffer Type (Note 2-1)	Description
1	GND	Gnd	Ground.
2	VDDPLL_1.8	P	1.8V Analog V_{DD} Decouple with 1.0 μ F and 0.1 μ F capacitors to ground.
3	VDDA_3.3	P	3.3V Analog V_{DD} .
4	RX-	I/O	Physical receive or transmit signal (- differential).

TABLE 2-1: KSZ8041NL PIN DESCRIPTION

Pin Number	Symbol	Buffer Type (Note 2-1)	Description
5	RX+	I/O	Physical receive or transmit signal (+ differential).
6	TX-	I/O	Physical transmit or receive signal (- differential).
7	TX+	I/O	Physical transmit or receive signal (+ differential).
8	XO	O	Crystal Feedback. This pin is used only in MII mode when a 25 MHz crystal is used. This pin is a no connect if oscillator or external clock source is used, or if RMII mode is selected.
9	XI / REFCLK	I	Crystal / Oscillator / External Clock Input: MII Mode: 25 MHz \pm 50 ppm (crystal, oscillator, or external clock) RMII Mode: 50 MHz \pm 50 ppm (oscillator, or external clock only)
10	REXT	I/O	Set physical transmit output current. Connect a 6.49 K Ω resistor in parallel with a 100 pF capacitor to ground on this pin.
11	MDIO	I/O	Management Interface (MII) Data I/O This pin requires an external 4.7 K Ω pull-up resistor.
12	MDC	I	Management Interface (MII) Clock Input This pin is synchronous to the MDIO data interface.
13	RXD3 / PHYAD0	Ipu/O	MII Mode: Receive Data Output[3]. (Note 2-2) Config Mode: The pull-up/pull-down value is latched as PHY-ADDR[0] during power-up / reset. See “Strap-In option – KSZ8041NL” for details.
14	RXD2 / PHYAD1	Ipd/O	MII Mode: Receive Data Output[2]. (Note 2-2) Config Mode: The pull-up/pull-down value is latched as PHY-ADDR[1] during power-up / reset. See “Strap-In option – KSZ8041NL” for details.
15	RXD1 / RXD[1] / PHYAD2	Ipd/O	MII Mode: Receive Data Output[1]. (Note 2-2) RMII Mode: Receive Data Output[1]. (Note 2-3) Config Mode: The pull-up/pull-down value is latched as PHYADDR[2] during power-up / reset. See “Strap-In option – KSZ8041NL” for details.
16	RXD0 / RXD[0] / DUPLEX	Ipu/O	MII Mode: Receive Data Output[0]. (Note 2-2). RMII Mode: Receive Data Output[0]. (Note 2-3). Config Mode: Latched as DUPLEX (register 0h, bit 8) during power-up / reset. See “Strap-In option – KSZ8041NL” for details.
17	VDDIO_3.3	P	3.3V Digital V _{DD} .
18	RXDV / CRSDV / CONFIG2	Ipd/O	MII Mode: Receive Data Valid Output. RMII Mode: Carrier Sense/Receive Data Valid Output. Config Mode: The pull-up/pull-down value is latched as CONFIG2 during power-up / reset. See “Strap-In option – KSZ8041NL” for details.

KSZ8041NL/RNL

TABLE 2-1: KSZ8041NL PIN DESCRIPTION

Pin Number	Symbol	Buffer Type (Note 2-1)	Description
19	RXC	O	MII Mode: Receive Clock Output.
20	RXER / RX_ER / ISO	lpd/O	MII Mode: Receive Error Output. RMII Mode: Receive Error Output. Config Mode: The pull-up/pull-down value is latched as ISOLATE during power-up / reset. See “Strap-In option – KSZ8041NL” for details.
21	INTRP	Opu	Interrupt Output: Programmable Interrupt Output Register 1Bh is the Interrupt Control/Status Register for programming the interrupt conditions and reading the interrupt status. Register 1Fh bit 9 sets the interrupt output to active low (default) or active high.
22	TXC	O	MII Mode: Transmit Clock Output.
23	TXEN / TX_EN	I	MII Mode: Transmit Enable Input. RMII Mode: Transmit Enable Input.
24	TXD0 / TXD[0]	I	MII Mode: Transmit Data Input[0] (Note 2-4). RMII Mode: Transmit Data Input[0] (Note 2-5).
25	TXD1 / TXD[1]	I	MII Mode: Transmit Data Input[1] (Note 2-4). RMII Mode: Transmit Data Input[1] (Note 2-5).
26	TXD2	I	MII Mode: Transmit Data Input[2] (Note 2-4).
27	TXD3	I	MII Mode: Transmit Data Input[3] (Note 2-4).
28	COL/CONFIG0	lpd/O	MII Mode: Collision Detect Output. Config Mode: The pull-up/pull-down value is latched as CONFIG0 during power-up / reset. See “Strap-In option – KSZ8041NL” for details.
29	CRS/CONFIG1	lpd/O	MII Mode: Collision Sense Output. Config Mode: The pull-up/pull-down value is latched as CONFIG1 during power-up / reset. See “Strap-In option – KSZ8041NL” for details.

TABLE 2-1: KSZ8041NL PIN DESCRIPTION

Pin Number	Symbol	Buffer Type (Note 2-1)	Description																					
30	LED0 / NWAYEN	Ipu/O	<p>LED Output: Programmable LED0 Output / Config Mode: Latched as Auto-Negotiation Enable (register 0h, bit 12) during power-up / reset. See Strap-In option – KSZ8041NL for details. The LED0 pin is programmable via register 1Eh bits [15:14], and is defined as follows:</p> <p>LED Mode = [00]</p> <table border="1"> <thead> <tr> <th>Link/Activity</th> <th>Pin State</th> <th>LED Definition</th> </tr> </thead> <tbody> <tr> <td>No Link</td> <td>H</td> <td>OFF</td> </tr> <tr> <td>Link</td> <td>L</td> <td>ON</td> </tr> <tr> <td>Activity</td> <td>Toggle</td> <td>Blinking</td> </tr> </tbody> </table> <p>LED Mode = [01]</p> <table border="1"> <thead> <tr> <th>Link</th> <th>Pin State</th> <th>LED Definition</th> </tr> </thead> <tbody> <tr> <td>No Link</td> <td>H</td> <td>OFF</td> </tr> <tr> <td>Link</td> <td>L</td> <td>ON</td> </tr> </tbody> </table> <p>LED Mode = [10] Reserved</p> <p>LED Mode = [11] Reserved</p>	Link/Activity	Pin State	LED Definition	No Link	H	OFF	Link	L	ON	Activity	Toggle	Blinking	Link	Pin State	LED Definition	No Link	H	OFF	Link	L	ON
Link/Activity	Pin State	LED Definition																						
No Link	H	OFF																						
Link	L	ON																						
Activity	Toggle	Blinking																						
Link	Pin State	LED Definition																						
No Link	H	OFF																						
Link	L	ON																						

KSZ8041NL/RNL

TABLE 2-1: KSZ8041NL PIN DESCRIPTION

Pin Number	Symbol	Buffer Type (Note 2-1)	Description																								
31	LED1 / SPEED	Ipu/O	<p>LED Output: Programmable LED1 Output / Config Mode: Latched as SPEED (register 0h, bit 13) during power-up / reset. See Strap-In option – KSZ8041NL for details. The LED1 pin is programmable via register 1Eh bits [15:14], and is defined as follows:</p> <table border="1"> <thead> <tr> <th colspan="3">LED Mode = [00]</th> </tr> <tr> <th>Speed</th> <th>Pin State</th> <th>LED Definition</th> </tr> </thead> <tbody> <tr> <td>10BT</td> <td>H</td> <td>OFF</td> </tr> <tr> <td>100BT</td> <td>L</td> <td>ON</td> </tr> </tbody> </table> <table border="1"> <thead> <tr> <th colspan="3">LED Mode = [01]</th> </tr> <tr> <th>Activity</th> <th>Pin State</th> <th>LED Definition</th> </tr> </thead> <tbody> <tr> <td>No Activity</td> <td>H</td> <td>OFF</td> </tr> <tr> <td>Activity</td> <td>Toggle</td> <td>Blinking</td> </tr> </tbody> </table> <p>LED Mode = [10] Reserved.</p> <p>LED Mode = [11] Reserved.</p>	LED Mode = [00]			Speed	Pin State	LED Definition	10BT	H	OFF	100BT	L	ON	LED Mode = [01]			Activity	Pin State	LED Definition	No Activity	H	OFF	Activity	Toggle	Blinking
LED Mode = [00]																											
Speed	Pin State	LED Definition																									
10BT	H	OFF																									
100BT	L	ON																									
LED Mode = [01]																											
Activity	Pin State	LED Definition																									
No Activity	H	OFF																									
Activity	Toggle	Blinking																									
32	RST#	I	Chip Reset (active low).																								
PADDLE	GND	Gnd	Ground.																								

Note 2-1 P = Power supply.
Gnd = Ground.
I = Input.
O = Output.
I/O = Bi-directional.
Ipd = Input with internal pull-down (40K ±30%).
Ipu = Input with internal pull-up (40K ±30%).
Opu = Output with internal pull-up (40K ±30%).
Ipu/O = Input with internal pull-up (40K ±30%) during power-up/reset; output pin otherwise.
Ipd/O = Input with internal pull-down (40K ±30%) during power-up/reset; output pin otherwise.

Note 2-2 MII Rx Mode: The RXD[3:0] bits are synchronous with RXCLK. When RXDV is asserted, RXD[3:0] presents valid data to MAC through the MII. RXD[3:0] is invalid when RXDV is de-asserted.

Note 2-3 RMII Rx Mode: The RXD[1:0] bits are synchronous with REF_CLK. For each clock period in which CRS_DV is asserted, two bits of recovered data are sent from the PHY.

Note 2-4 MII Tx Mode: The TXD[3:0] bits are synchronous with TXCLK. When TXEN is asserted, TXD[3:0] presents valid data from the MAC through the MII. TXD[3..0] has no effect when TXEN is de-asserted.

Note 2-5 RMII Tx Mode: The TXD[1:0] bits are synchronous with REF_CLK. For each clock period in which TX_EN is asserted, two bits of data are received by the PHY from the MAC.

2.2 STRAP-IN OPTION – KSZ8041NL

Pin strap-ins are latched during power-up or reset. In some systems, the MAC receive input pins may drive high during power-up or reset, and consequently cause the PHY strap-in pins on the MII/RMII signals to be latched high. In this case, it is recommended to add 1K pull-downs on these PHY strap-in pins to ensure the PHY does not strap-in to ISO-LATE mode, or is not configured with an incorrect PHY Address.

TABLE 2-2: STRAP-IN OPTION – KSZ8041NL

Pin Number	Pin Name	Type (Note 2-1)	Pin Function																		
15	PHYAD2	lpd/O	The PHY Address is latched at power-up / reset and is configurable to any value from 1 to 7. The default PHY Address is 00001. PHY Address bits [4:3] are always set to '00'.																		
14	PHYAD1	lpd/O																			
13	PHYAD0	lpu/O																			
18	CONFIG2	lpd/O	The CONFIG[2:0] strap-in pins are latched at power-up / reset and are defined as follows:																		
29	CONFIG1	lpd/O																			
28	CONFIG0	lpd/O	<table border="1"> <thead> <tr> <th>CONFIG[2:0]</th> <th>Mode</th> </tr> </thead> <tbody> <tr> <td>000</td> <td>MII (default)</td> </tr> <tr> <td>001</td> <td>RMII</td> </tr> <tr> <td>010</td> <td>Reserved – not used</td> </tr> <tr> <td>011</td> <td>Reserved – not used</td> </tr> <tr> <td>100</td> <td>MII 100Mbps Preamble Restore</td> </tr> <tr> <td>101</td> <td>Reserved – not used</td> </tr> <tr> <td>110</td> <td>Reserved – not used</td> </tr> <tr> <td>111</td> <td>Reserved – not used</td> </tr> </tbody> </table>	CONFIG[2:0]	Mode	000	MII (default)	001	RMII	010	Reserved – not used	011	Reserved – not used	100	MII 100Mbps Preamble Restore	101	Reserved – not used	110	Reserved – not used	111	Reserved – not used
CONFIG[2:0]	Mode																				
000	MII (default)																				
001	RMII																				
010	Reserved – not used																				
011	Reserved – not used																				
100	MII 100Mbps Preamble Restore																				
101	Reserved – not used																				
110	Reserved – not used																				
111	Reserved – not used																				
20	ISO	lpd/O	ISOLATE Mode: Pull-up = Enable Pull-down (default) = Disable During power-up / reset, this pin value is latched into register 0h bit 10.																		
31	SPEED	lpu/O	SPEED Mode: Pull-up (default) = 100 Mbps Pull-down = 10 Mbps During power-up / reset, this pin value is latched into register 0h bit 13 as the Speed Select, and also is latched into register 4h (Auto-Negotiation Advertisement) as the Speed capability support.																		
16	DUPLEX	lpu/O	DUPLEX Mode: Pull-up (default) = Half Duplex Pull-down = Full Duplex During power-up / reset, this pin value is latched into register 0h bit 8 as the Duplex Mode.																		
30	NWAYEN	lpu/O	Nway Auto-Negotiation Enable: Pull-up (default) = Enable Auto-Negotiation Pull-down = Disable Auto-Negotiation During power-up / reset, this pin value is latched into register 0h bit 12.																		

Note 2-1 lpu/O = Input with internal pull-up (40K ±30%) during power-up/reset; output pin otherwise.
lpd/O = Input with internal pull-down (40K ±30%) during power-up/reset; output pin otherwise.

KSZ8041NL/RNL

2.3 KSZ8041RNL Pin Description and Configuration

FIGURE 2-2: KSZ8041RNL 32-QFN PIN ASSIGNMENT (TOP VIEW)

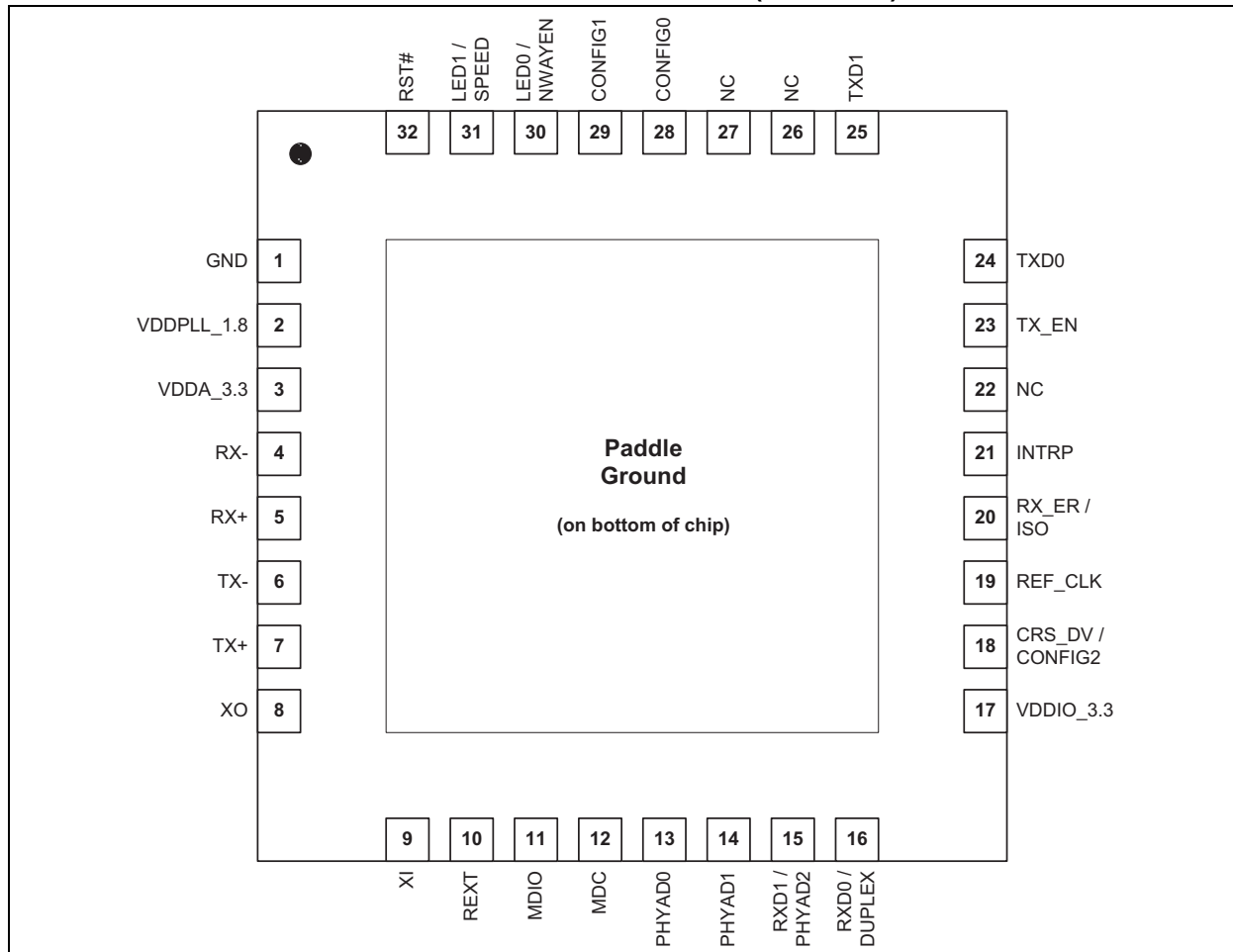

TABLE 2-3: KSZ8041RNL PIN DESCRIPTION

Pin Number	Pin Name	Type (Note 2-1)	Pin Function
1	GND	Gnd	Ground.
2	VDDPLL_1.8	P	1.8V Analog V_{DD} Decouple with 1.0 μ F and 0.1 μ F capacitors to ground.
3	VDDA_3.3	P	3.3V Analog V_{DD} .
4	RX-	I/O	Physical receive or transmit signal (- differential).
5	RX+	I/O	Physical receive or transmit signal (+ differential).
6	TX-	I/O	Physical transmit or receive signal (- differential).
7	TX+	I/O	Physical transmit or receive signal (+ differential).
8	XO	O	Crystal Feedback for 25 MHz Crystal. This pin is a no connect if oscillator or external clock source is used.
9	XI	I	Crystal / Oscillator / External Clock Input. 25 MHz \pm 50 ppm.
10	REXT	I/O	Set physical transmit output current. Connect a 6.49 k Ω resistor in parallel with a 100 pF capacitor to ground on this pin. See KSZ8041RNL reference schematics.

KSZ8041NL/RNL

TABLE 2-3: KSZ8041RNL PIN DESCRIPTION

Pin Number	Pin Name	Type (Note 2-1)	Pin Function
11	MDIO	I/O	Management Interface (MII) Data I/O This pin requires an external 4.7 kΩ pull-up resistor.
12	MDC	I	Management Interface (MII) Clock Input This pin is synchronous to the MDIO data interface.
13	PHYAD0	Ipu/O	The pull-up/pull-down value is latched as PHYADDR[0] during power-up / reset. See Strap-In option – KSZ8041RNL for details.
14	PHYAD1	Ipd/O	The pull-up/pull-down value is latched as PHYADDR[1] during power-up / reset. See Strap-In option – KSZ8041RNL for details.
15	RXD1 / PHYAD2	Ipd/O	RMII Mode: RMII Receive Data Output[1] (Note 2-2). Config Mode: The pull-up/pull-down value is latched as PHYADDR[2] during power-up / reset. See Strap-In option – KSZ8041RNL for details.
16	RXD0 / DUPLEX	Ipu/O	RMII Mode: RMII Receive Data Output[0] (Note 2-2). Config Mode: Latched as DUPLEX (register 0h, bit 8) during power-up / reset. See Strap-In option – KSZ8041RNL for details.
17	VDDIO_3.3	P	3.3V Digital V _{DD} .
18	CRSDV / CONFIG2	Ipd/O	RMII Mode: Carrier Sense/Receive Data Valid Output / Config Mode: The pull-up/pull-down value is latched as CONFIG2 during power-up / reset. See Strap-In option – KSZ8041RNL for details.
19	REF_CLK	O	50 MHz Clock Output. This pin provides the 50 MHz RMII reference clock output to the MAC.
20	RXER / RX_ER / ISO	Ipd/O	RMII Mode: Receive Error Output. Config Mode: The pull-up/pull-down value is latched as ISO-LATE during power-up / reset. See Strap-In option – KSZ8041RNL for details.
21	INTRP	Opu	Interrupt Output: Programmable Interrupt Output Register 1Bh is the Interrupt Control/Status Register for programming the interrupt conditions and reading the interrupt status. Register 1Fh bit 9 sets the interrupt output to active low (default) or active high.
22	NC	O	No Connect.
23	TX_EN	I	RMII Transmit Enable Input.
24	TXD0	I	RMII Transmit Data Input[0]. (Note 2-3)
25	TXD1	I	RMII Transmit Data Input[1]. (Note 2-3)
26	NC	I	No Connect.
27	NC	I	No Connect.
28	CONFIG0	Ipd/O	The pull-up/pull-down value is latched as CONFIG0 during power-up / reset. See Strap-In option – KSZ8041RNL for details.
29	CONFIG1	Ipd/O	The pull-up/pull-down value is latched as CONFIG1 during power-up / reset. See Strap-In option – KSZ8041RNL for details.

KSZ8041NL/RNL

TABLE 2-3: KSZ8041RNL PIN DESCRIPTION

Pin Number	Pin Name	Type (Note 2-1)	Pin Function																											
30	LED0 / NWAYEN	Ipu/O	<p>LED Output: Programmable LED0 Output / . Config Mode: Latched as Auto-Negotiation Enable (register 0h, bit 12) during power-up / reset. See Strap-In option – KSZ8041RNL for details. The LED0 pin is programmable via register 1Eh bits [15:14], and is defined as follows:</p> <table border="1"> <thead> <tr> <th colspan="3">LED Mode = [00]</th> </tr> <tr> <th>Link/Activity</th> <th>Pin State</th> <th>LED Definition</th> </tr> </thead> <tbody> <tr> <td>No Link</td> <td>H</td> <td>OFF</td> </tr> <tr> <td>Link</td> <td>L</td> <td>ON</td> </tr> <tr> <td>Activity</td> <td>Toggle</td> <td>Blinking</td> </tr> </tbody> </table> <table border="1"> <thead> <tr> <th colspan="3">LED Mode = [01]</th> </tr> <tr> <th>Link</th> <th>Pin State</th> <th>LED Definition</th> </tr> </thead> <tbody> <tr> <td>No Link</td> <td>H</td> <td>OFF</td> </tr> <tr> <td>Link</td> <td>L</td> <td>ON</td> </tr> </tbody> </table> <p>LED Mode = [10], [11] Reserved.</p>	LED Mode = [00]			Link/Activity	Pin State	LED Definition	No Link	H	OFF	Link	L	ON	Activity	Toggle	Blinking	LED Mode = [01]			Link	Pin State	LED Definition	No Link	H	OFF	Link	L	ON
LED Mode = [00]																														
Link/Activity	Pin State	LED Definition																												
No Link	H	OFF																												
Link	L	ON																												
Activity	Toggle	Blinking																												
LED Mode = [01]																														
Link	Pin State	LED Definition																												
No Link	H	OFF																												
Link	L	ON																												
31	LED1 / SPEED	Ipu/O	<p>LED Output: Programmable LED1 Output / . Config Mode: Latched as SPEED (register 0h, bit 13) during power-up / reset. See Strap-In option – KSZ8041RNL for details. The LED1 pin is programmable via register 1Eh bits [15:14], and is defined as follows:</p> <table border="1"> <thead> <tr> <th colspan="3">LED Mode = [00]</th> </tr> <tr> <th>Speed</th> <th>Pin State</th> <th>LED Definition</th> </tr> </thead> <tbody> <tr> <td>10BT</td> <td>H</td> <td>OFF</td> </tr> <tr> <td>100BT</td> <td>L</td> <td>ON</td> </tr> </tbody> </table> <table border="1"> <thead> <tr> <th colspan="3">LED Mode = [01]</th> </tr> <tr> <th>Activity</th> <th>Pin State</th> <th>LED Definition</th> </tr> </thead> <tbody> <tr> <td>No Activity</td> <td>H</td> <td>OFF</td> </tr> <tr> <td>Activity</td> <td>Toggle</td> <td>Blinking</td> </tr> </tbody> </table> <p>LED Mode = [10], [11] Reserved.</p>	LED Mode = [00]			Speed	Pin State	LED Definition	10BT	H	OFF	100BT	L	ON	LED Mode = [01]			Activity	Pin State	LED Definition	No Activity	H	OFF	Activity	Toggle	Blinking			
LED Mode = [00]																														
Speed	Pin State	LED Definition																												
10BT	H	OFF																												
100BT	L	ON																												
LED Mode = [01]																														
Activity	Pin State	LED Definition																												
No Activity	H	OFF																												
Activity	Toggle	Blinking																												
32	RST#	I	Chip Reset (active low).																											
PADDLE	GND	Gnd	Ground.																											

- Note 2-1** P = Power supply.
Gnd = Ground.
I = Input.
O = Output.
I/O = Bi-directional.
Opu = Output with internal pull-up (40K \pm 30%).
Ipu/O = Input with internal pull-up (40K \pm 30%) during power-up/reset; output pin otherwise.
Ipd/O = Input with internal pull-down (40K \pm 30%) during power-up/reset; output pin otherwise.
- Note 2-2** RMII Rx Mode: The RXD[1:0] bits are synchronous with REF_CLK. For each clock period in which CRS_DV is asserted, two bits of recovered data are sent from the PHY.
- Note 2-3** RMII Tx Mode: The TXD[1:0] bits are synchronous with REF_CLK. For each clock period in which TX_EN is asserted, two bits of data are received by the PHY from the MAC.

KSZ8041NL/RNL

2.4 STRAP-IN OPTION – KSZ8041RNL

Pin strap-ins are latched during power-up or reset. In some systems, the MAC receive input pins may drive high during power-up or reset, and consequently cause the PHY strap-in pins on the RMI signals to be latched high. In this case, it is recommended to add 1K pull-downs on these PHY strap-in pins to ensure the PHY does not strap-in to ISOLATE mode, or is not configured with an incorrect PHY Address.

TABLE 2-4: STRAP-IN OPTION – KSZ8041RNL

Pin Number	Pin Name	Type (Note 2-1)	Pin Function																		
15	PHYAD2	lpd/O	The PHY Address is latched at power-up / reset and is configurable to any value from 1 to 7. The default PHY Address is 00001. PHY Address bits [4:3] are always set to '00'.																		
14	PHYAD1	lpd/O																			
13	PHYAD0	lpu/O																			
18	CONFIG2	lpd/O	The CONFIG[2:0] strap-in pins are latched at power-up / reset and are defined as follows:																		
29	CONFIG1	lpd/O																			
28	CONFIG0	lpd/O	<table border="1"> <thead> <tr> <th>CONFIG[2:0]</th> <th>Mode</th> </tr> </thead> <tbody> <tr> <td>000</td> <td>Reserved – not used</td> </tr> <tr> <td>001</td> <td>RMI</td> </tr> <tr> <td>010</td> <td>Reserved – not used</td> </tr> <tr> <td>011</td> <td>Reserved – not used</td> </tr> <tr> <td>100</td> <td>Reserved – not used</td> </tr> <tr> <td>101</td> <td>Reserved – not used</td> </tr> <tr> <td>110</td> <td>Reserved – not used</td> </tr> <tr> <td>111</td> <td>Reserved – not used</td> </tr> </tbody> </table>	CONFIG[2:0]	Mode	000	Reserved – not used	001	RMI	010	Reserved – not used	011	Reserved – not used	100	Reserved – not used	101	Reserved – not used	110	Reserved – not used	111	Reserved – not used
			CONFIG[2:0]	Mode																	
			000	Reserved – not used																	
			001	RMI																	
			010	Reserved – not used																	
			011	Reserved – not used																	
			100	Reserved – not used																	
			101	Reserved – not used																	
			110	Reserved – not used																	
111	Reserved – not used																				
20	ISO	lpd/O	ISOLATE Mode: Pull-up = Enable Pull-down (default) = Disable During power-up / reset, this pin value is latched into register 0h bit 10.																		
31	SPEED	lpu/O	SPEED Mode: Pull-up (default) = 100 Mbps Pull-down = 10 Mbps During power-up / reset, this pin value is latched into register 0h bit 13 as the Speed Select, and also is latched into register 4h (Auto-Negotiation Advertisement) as the Speed capability support.																		
16	DUPLEX	lpu/O	DUPLEX Mode: Pull-up (default) = Half Duplex Pull-down = Full Duplex During power-up / reset, this pin value is latched into register 0h bit 8 as the Duplex Mode.																		
30	NWAYEN	lpu/O	Nway Auto-Negotiation Enable: Pull-up (default) = Enable Auto-Negotiation Pull-down = Disable Auto-Negotiation During power-up / reset, this pin value is latched into register 0h bit 12.																		

Note 2-1 lpu/O = Input with internal pull-up (40K ±30%) during power-up/reset; output pin otherwise.
lpd/O = Input with internal pull-down (40K ±30%) during power-up/reset; output pin otherwise.

3.0 FUNCTIONAL DESCRIPTION

The KSZ8041NL is a single 3.3V supply Fast Ethernet transceiver. It is fully compliant with the IEEE 802.3u Specification.

On the media side, the KSZ8041NL supports 10BASE-T and 100BASE-TX with HP auto MDI/MDI-X for reliable detection of and correction for straight-through and crossover cables.

The KSZ8041NL offers a choice of MII or RMII data interface connection with the MAC processor. The MII management bus option gives the MAC processor complete access to the KSZ8041NL control and status registers. Additionally, an interrupt pin eliminates the need for the processor to poll for PHY status change.

Physical signal transmission and reception are enhanced through the use of patented analog circuitries that make the design more efficient and allow for lower power consumption and smaller chip die size.

The KSZ8041RNL is an enhanced RMII version of the KSZ8041NL that does not require a 50 MHz system clock. It uses a 25 MHz crystal for its input reference clock and outputs a 50 MHz RMII reference clock to the MAC.

3.1 100BASE-TX Transmit

The 100BASE-TX transmit function performs parallel-to-serial conversion, 4B/5B coding, scrambling, NRZ-to-NRZI conversion, and MLT3 encoding and transmission.

The circuitry starts with a parallel-to-serial conversion, which converts the MII data from the MAC into a 125 MHz serial bit stream. The data and control stream is then converted into 4B/5B coding, followed by a scrambler. The serialized data is further converted from NRZ-to-NRZI format, and then transmitted in MLT3 current output.

The output current is set by an external 6.49 k Ω 1% resistor for the 1:1 transformer ratio. It has typical rise/fall times of 4 ns and complies with the ANSI TP-PMD standard regarding amplitude balance, overshoot and timing jitter. The wave-shaped 10BASE-T output drivers are also incorporated into the 100BASE-TX drivers.

3.2 100BASE-TX Receive

The 100BASE-TX receiver function performs adaptive equalization, DC restoration, MLT3-to-NRZI conversion, data and clock recovery, NRZI-to-NRZ conversion, de-scrambling, 4B/5B decoding, and serial-to-parallel conversion.

The receiving side starts with the equalization filter to compensate for inter-symbol interference (ISI) over the twisted pair cable. Since the amplitude loss and phase distortion is a function of the cable length, the equalizer must adjust its characteristics to optimize performance. In this design, the variable equalizer makes an initial estimation based on comparisons of incoming signal strength against some known cable characteristics, and then tunes itself for optimization. This is an ongoing process and self-adjusts against environmental changes such as temperature variations.

Next, the equalized signal goes through a DC restoration and data conversion block. The DC restoration circuit is used to compensate for the effect of baseline wander and to improve the dynamic range. The differential data conversion circuit converts the MLT3 format back to NRZI. The slicing threshold is also adaptive.

The clock recovery circuit extracts the 125 MHz clock from the edges of the NRZI signal. This recovered clock is then used to convert the NRZI signal into the NRZ format. This signal is sent through the de-scrambler followed by the 4B/5B decoder. Finally, the NRZ serial data is converted to the MII format and provided as the input data to the MAC.

3.3 PLL Clock Synthesizer

The KSZ8041NL/RNL generates 125 MHz, 25 MHz and 20 MHz clocks for system timing. Internal clocks are generated from an external 25 MHz crystal or oscillator. For the KSZ8041NL in RMII mode, these internal clocks are generated from an external 50 MHz oscillator or system clock.

3.4 Scrambler/De-Scrambler (100BASE-TX only)

The purpose of the scrambler is to spread the power spectrum of the signal in order to reduce EMI and baseline wander.

3.5 10BASE-T Transmit

The 10BASE-T drivers are incorporated with the 100BASE-TX drivers to allow for transmission using the same magnetic. The drivers also perform internal wave-shaping and pre-emphasize, and output 10BASE-T signals with a typical amplitude of 2.5V peak. The 10BASE-T signals have harmonic contents that are at least 27 dB below the fundamental frequency when driven by an all-ones Manchester-encoded signal.

KSZ8041NL/RNL

3.6 10BASE-T Receive

On the receive side, input buffer and level detecting squelch circuits are employed. A differential input receiver circuit and a PLL performs the decoding function. The Manchester-encoded data stream is separated into clock signal and NRZ data. A squelch circuit rejects signals with levels less than 400 mV or with short pulse widths to prevent noise at the RX+ and RX- inputs from falsely trigger the decoder. When the input exceeds the squelch limit, the PLL locks onto the incoming signal and the KSZ8041NL/RNL decodes a data frame. The receive clock is kept active during idle periods in between data reception.

3.7 SQE and Jabber Function (10BASE-T only)

In 10BASE-T operation, a short pulse is put out on the COL pin after each frame is transmitted. This SQE Test is required as a test of the 10BASE-T transmit/receive path. If transmit enable (TXEN) is high for more than 20 ms (jabbering), the 10BASE-T transmitter is disabled and COL is asserted high. If TXEN is then driven low for more than 250 ms, the 10BASE-T transmitter is re-enabled and COL is de-asserted (returns to low).

3.8 Auto-Negotiation

The KSZ8041NL/RNL conforms to the auto-negotiation protocol, defined in Clause 28 of the IEEE 802.3u specification. Auto-negotiation is enabled by either hardware pin strapping (pin 30) or software (register 0h bit 12).

Auto-negotiation allows unshielded twisted pair (UTP) link partners to select the highest common mode of operation. Link partners advertise their capabilities to each other, and then compare their own capabilities with those they received from their link partners. The highest speed and duplex setting that is common to the two link partners is selected as the mode of operation.

The following list shows the speed and duplex operation mode from highest to lowest.

- Priority 1: 100BASE-TX, full-duplex
- Priority 2: 100BASE-TX, half-duplex
- Priority 3: 10BASE-T, full-duplex
- Priority 4: 10BASE-T, half-duplex

If auto-negotiation is not supported or the KSZ8041NL/RNL link partner is forced to bypass auto-negotiation, the KSZ8041NL/RNL sets its operating mode by observing the signal at its receiver. This is known as parallel detection, and allows the KSZ8041NL/RNL to establish link by listening for a fixed signal protocol in the absence of auto-negotiation advertisement protocol.

The auto-negotiation link up process is shown in the flow chart illustrated as [Figure 3-1](#).

FIGURE 3-1: AUTO-NEGOTIATION FLOW CHART

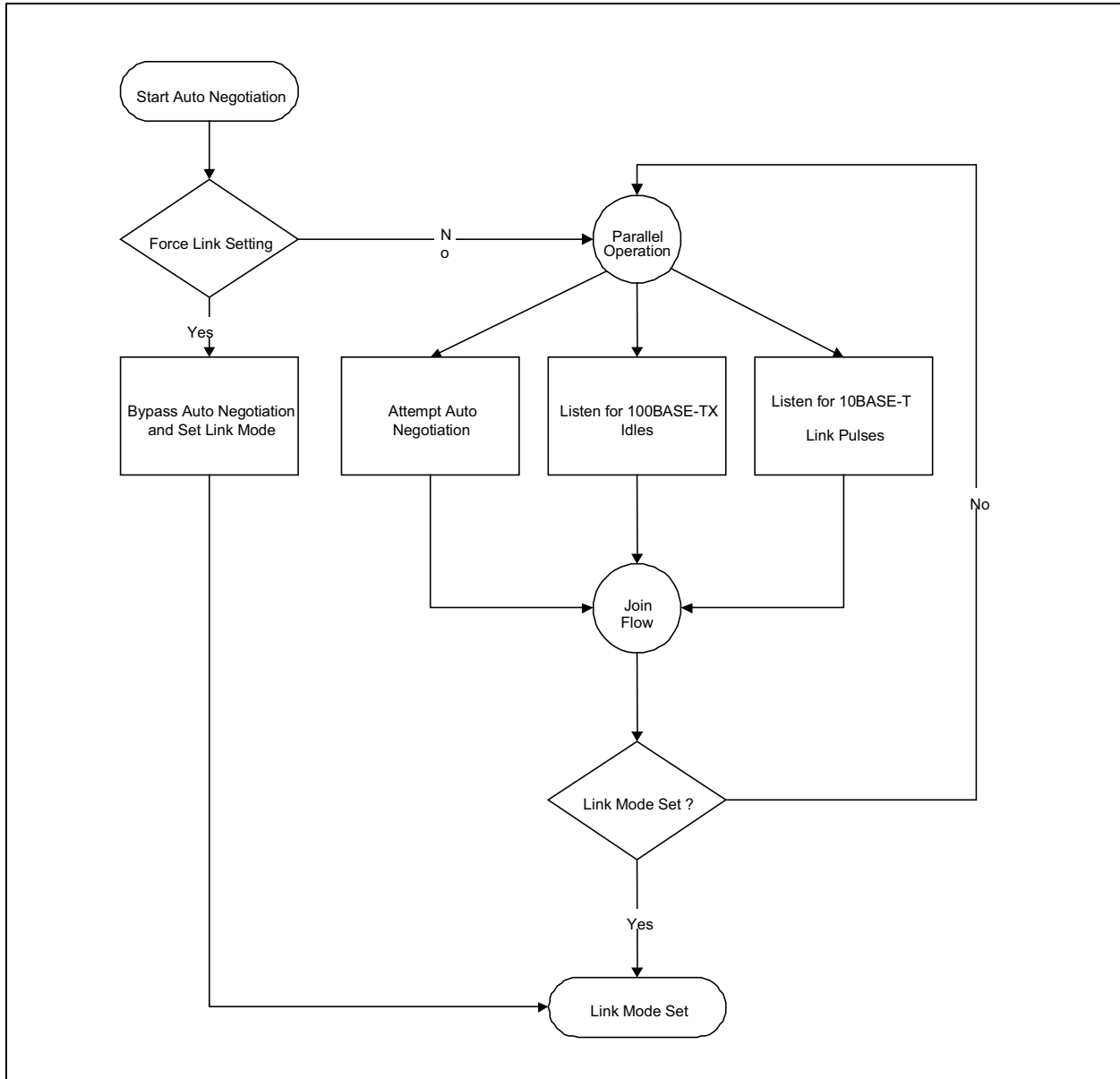

3.9 MII Management (MIIM) Interface

The KSZ8041NL/RNL supports the IEEE 802.3 MII Management Interface, also known as the Management Data Input / Output (MDIO) Interface. This interface allows upper-layer devices to monitor and control the state of the KSZ8041NL/RNL. An external device with MIIM capability is used to read the PHY status and/or configure the PHY settings. Further details on the MIIM interface can be found in Clause 22.2.4 of the IEEE 802.3 Specification.

The MIIM interface consists of the following:

- A physical connection that incorporates the clock line (MDC) and the data line (MDIO).
- A specific protocol that operates across the aforementioned physical connection that allows an external controller to communicate with one or more PHY devices. Each KSZ8041NL/RNL device is assigned a unique PHY address between 1 and 7 by its PHYAD[2:0] strapping pins. Also, every KSZ8041NL/RNL device supports the broadcast PHY address 0, as defined per the IEEE 802.3 Specification, which can be used to read/write to a single KSZ8041NL/RNL device, or write to multiple KSZ8041NL/RNL devices simultaneously.
- A set of 16-bit MDIO registers. Register [0:6] are required, and their functions are defined per the IEEE 802.3 Specification. The additional registers are provided for expanded functionality.

KSZ8041NL/RNL

Table 3-1 shows the MII Management frame format for the KSZ8041NL/RNL.

TABLE 3-1: MII MANAGEMENT FRAME FORMAT

	Preamble	Start of Frame	Read/Write OP Code	PHY Address Bits [4:0]	REG Address Bits [4:0]	TA	Data Bits [15:0]	Idle
Read	32 1's	01	10	00AAA	RRRRR	Z0	DDDDDDDD_DDDDDDDD	Z
Write	32 1's	01	01	00AAA	RRRRR	10	DDDDDDDD_DDDDDDDD	Z

3.10 Interrupt (INTRP)

INTRP (pin 21) is an optional interrupt signal that is used to inform the external controller that there has been a status update to the KSZ8041NL/RNL PHY register. Bits[15:8] of register 1Bh are the interrupt control bits, and are used to enable and disable the conditions for asserting the INTRP signal. Bits[7:0] of register 1Bh are the interrupt status bits, and are used to indicate which interrupt conditions have occurred. The interrupt status bits are cleared after reading register 1Bh.

Bit 9 of register 1Fh sets the interrupt level to active high or active low.

3.11 MII Data Interface (KSZ8041NL only)

The Media Independent Interface (MII) is specified in Clause 22 of the IEEE 802.3 Specification. It provides a common interface between physical layer and MAC layer devices, and has the following key characteristics:

- Supports 10 Mbps and 100 Mbps data rates.
- Uses a 25 MHz reference clock, sourced by the PHY.
- Provides independent 4-bit wide (nibble) transmit and receive data paths.
- Contains two distinct groups of signals: one for transmission and the other for reception.

By default, the KSZ8041NL is configured to MII mode after it is power-up or reset with the following:

- A 25 MHz crystal connected to XI, XO (pins 9, 8), or an external 25 MHz clock source (oscillator) connected to XI.
- CONFIG[2:0] (pins 18, 29, 28) set to '000' (default setting).

3.12 MII Signal Definition (KSZ8041NL only)

Table 3-2 describes the MII signals. Refer to Clause 22 of the IEEE 802.3 Specification for detailed information.

TABLE 3-2: MII SIGNAL DEFINITION

MII Signal Name	Direction (with respect to PHY, KSZ8041NL signal)	Direction (with respect to MAC)	Description
TXC	Output	Input	Transmit Clock (2.5 MHz for 10 Mbps; 25 MHz for 100 Mbps)
TXEN	Input	Output	Transmit Enable
TXD[3:0]	Input	Output	Transmit Data [3:0]
RXC	Output	Input	Receive Clock (2.5 MHz for 10 Mbps; 25 MHz for 100 Mbps)
RXDV	Output	Input	Receive Data Valid
RXD[3:0]	Output	Input	Receive Data [3:0]
RXER	Output	Input, or (not required)	Receive Error
CRS	Output	Input	Carrier Sense
COL	Output	Input	Collision Detection

3.12.1 TRANSMIT CLOCK (TXC)

TXC is sourced by the PHY. It is a continuous clock that provides the timing reference for TXEN and TXD[3:0]. TXC is 2.5 MHz for 10 Mbps operation and 25 MHz for 100 Mbps operation.

3.12.2 TRANSMIT ENABLE (TXEN)

TXEN indicates the MAC is presenting nibbles on TXD[3:0] for transmission. It is asserted synchronously with the first nibble of the preamble and remains asserted while all nibbles to be transmitted are presented on the MII, and is negated prior to the first TXC following the final nibble of a frame.

TXEN transitions synchronously with respect to TXC.

3.12.3 TRANSMIT DATA [3:0] (TXD[3:0])

TXD[3:0] transitions synchronously with respect to TXC. When TXEN is asserted, TXD[3:0] are accepted for transmission by the PHY. TXD[3:0] is "00" to indicate idle when TXEN is de-asserted. Values other than "00" on TXD[3:0] while TXEN is de-asserted are ignored by the PHY.

3.12.4 RECEIVE CLOCK (RXC)

RXC provides the timing reference for RXDV, RXD[3:0], and RXER.

- In 10 Mbps mode, RXC is recovered from the line while carrier is active. RXC is derived from the PHY's reference clock when the line is idle, or link is down.
- In 100 Mbps mode, RXC is continuously recovered from the line. If link is down, RXC is derived from the PHY's reference clock.

RXC is 2.5 MHz for 10 Mbps operation and 25 MHz for 100 Mbps operation.

3.12.5 RECEIVE DATA VALID (RXDV)

RXDV is driven by the PHY to indicate that the PHY is presenting recovered and decoded nibbles on RXD[3:0].

- In 10 Mbps mode, RXDV is asserted with the first nibble of the SFD (Start of Frame Delimiter), "5D", and remains asserted until the end of the frame.
- In 100 Mbps mode, RXDV is asserted from the first nibble of the preamble to the last nibble of the frame.

RXDV transitions synchronously with respect to RXC.

3.12.6 RECEIVE DATA [3:0] (RXD[3:0])

RXD[3:0] transitions synchronously with respect to RXC. For each clock period in which RXDV is asserted, RXD[3:0] transfers a nibble of recovered data from the PHY.

3.12.7 RECEIVE ERROR (RXER)

RXER is asserted for one or more RXC periods to indicate that a Symbol Error (e.g. a coding error that a PHY is capable of detecting, and that may otherwise be undetectable by the MAC sub-layer) was detected somewhere in the frame presently being transferred from the PHY.

RXER transitions synchronously with respect to RXC. While RXDV is de-asserted, RXER has no effect on the MAC.

3.12.8 CARRIER SENSE (CRS)

CRS is asserted and de-asserted as follows:

- In 10 Mbps mode, CRS assertion is based on the reception of valid preambles. CRS de-assertion is based on the reception of an end-of-frame (EOF) marker.
- In 100 Mbps mode, CRS is asserted when a start-of-stream delimiter, or /J/K symbol pair is detected. CRS is de-asserted when an end-of-stream delimiter, or /T/R symbol pair is detected. Additionally, the PMA layer de-asserts CRS if IDLE symbols are received without /T/R.

3.12.9 COLLISION (COL)

COL is asserted in half-duplex mode whenever the transmitter and receiver are simultaneously active on the line. This is used to inform the MAC that a collision has occurred during its transmission to the PHY.

COL transitions asynchronously with respect to TXC and RXC.

KSZ8041NL/RNL

3.13 Reduced MII (RMII) Data Interface

The Reduced Media Independent Interface (RMII) specifies a low pin count Media Independent Interface (MII). It provides a common interface between physical layer and MAC layer devices, and has the following key characteristics:

- Supports 10 Mbps and 100 Mbps data rates.
- Uses a 50 MHz reference clock.
- Provides independent 2-bit wide (di-bit) transmit and receive data paths.
- Contains two distinct groups of signals: one for transmission and the other for reception.

The KSZ8041NL is configured in RMII mode after it is power-up or reset with the following:

- A 50 MHz reference clock connected to REFCLK (pin 9).
- CONFIG[2:0] (pins 18, 29, 28) set to '001'.

The KSZ8041RNL is configured in RMII mode and outputs the 50 MHz RMII reference clock to the MAC on REF_CLK (pin 19) after it is power-up or reset with the following:

- A 25 MHz crystal connected to XI (pin 9) and XO (pin 8), or a 25MHz reference clock connected to XI (pin 9).
- CONFIG[2:0] (pins 18, 29, 28) set to '001'.

In RMII mode, unused MII signals, TXD[3:2] (pins 27, 26), are tied to ground.

3.14 RMII Signal Definition

[Table 3-3](#) and [Table 3-4](#) describe the RMII signals for KSZ8041NL and KSZ8041RNL. Refer to RMII Specification for detailed information.

TABLE 3-3: RMII SIGNAL DESCRIPTION – KSZ8041NL

RMII Signal Name	Direction (with respect to PHY, KSZ8041NL signal)	Direction (with respect to MAC)	Description
REF_CLK	Input	Input or Output	Synchronous 50 MHz clock reference for receive, transmit and control interface
TX_EN	Input	Output	Transmit Enable
TXD[1:0]	Input	Output	Transmit Data [1:0]
CRS_DV	Output	Input	Carrier Sense/Receive Data Valid
RXD[1:0]	Output	Input	Receive Data [1:0]
RX_ER	Output	Input, or (not required)	Receive Error

TABLE 3-4: RMII SIGNAL DESCRIPTION – KSZ8041RNL

RMII Signal Name	Direction (with respect to PHY, KSZ8041RNL signal)	Direction (with respect to MAC)	Description
REF_CLK	Output	Input	Synchronous 50 MHz clock reference for receive, transmit and control interface
TX_EN	Input	Output	Transmit Enable
TXD[1:0]	Input	Output	Transmit Data [1:0]
CRS_DV	Output	Input	Carrier Sense/Receive Data Valid
RXD[1:0]	Output	Input	Receive Data [1:0]
RX_ER	Output	Input, or (not required)	Receive Error

3.14.1 REFERENCE CLOCK (REF_CLK)

REF_CLK is a continuous 50 MHz clock that provides the timing reference for TX_EN, TXD[1:0], CRS_DV, RXD[1:0], and RX_ER.

The KSZ8041NL inputs the 50 MHz REF_CLK from the MAC or system board.

The KSZ8041RNL generates the 50 MHz RMII REF_CLK and outputs it to the MAC.

3.14.2 TRANSMIT ENABLE (TX_EN)

TX_EN indicates that the MAC is presenting di-bits on TXD[1:0] for transmission. It is asserted synchronously with the first nibble of the preamble and remains asserted while all di-bits to be transmitted are presented on the RMII, and is negated prior to the first REF_CLK following the final di-bit of a frame.

TX_EN transitions synchronously with respect to REF_CLK.

3.14.3 TRANSMIT DATA [1:0] (TXD[1:0])

TXD[1:0] transitions synchronously with respect to REF_CLK. When TX_EN is asserted, TXD[1:0] are accepted for transmission by the PHY. TXD[1:0] is "00" to indicate idle when TX_EN is de-asserted. Values other than "00" on TXD[1:0] while TX_EN is de-asserted are ignored by the PHY.

3.14.4 CARRIER SENSE/RECEIVE DATA VALID (CRS_DV)

CRS_DV is asserted by the PHY when the receive medium is non-idle. It is asserted asynchronously on detection of carrier. This is when squelch is passed in 10 Mbps mode, and when 2 non-contiguous zeroes in 10 bits are detected in 100 Mbps mode. Loss of carrier results in the de-assertion of CRS_DV.

So long as carrier detection criteria are met, CRS_DV remains asserted continuously from the first recovered di-bit of the frame through the final recovered di-bit, and it is negated prior to the first REF_CLK that follows the final di-bit. The data on RXD[1:0] is considered valid once CRS_DV is asserted. However, since the assertion of CRS_DV is asynchronous relative to REF_CLK, the data on RXD[1:0] is "00" until proper receive signal decoding takes place.

3.14.5 RECEIVE DATA [1:0] (RXD[1:0])

RXD[1:0] transitions synchronously to REF_CLK. For each clock period in which CRS_DV is asserted, RXD[1:0] transfers two bits of recovered data from the PHY. RXD[1:0] is "00" to indicate idle when CRS_DV is de-asserted. Values other than "00" on RXD[1:0] while CRS_DV is de-asserted are ignored by the MAC.

3.14.6 RECEIVE ERROR (RX_ER)

RX_ER is asserted for one or more REF_CLK periods to indicate that a Symbol Error (e.g. a coding error that a PHY is capable of detecting, and that may otherwise be undetectable by the MAC sub-layer) was detected somewhere in the frame presently being transferred from the PHY.

RX_ER transitions synchronously with respect to REF_CLK. While CRS_DV is de-asserted, RX_ER has no effect on the MAC.

3.14.7 COLLISION DETECTION

The MAC regenerates the COL signal of the MII from TX_EN and CRS_DV.

KSZ8041NL/RNL

3.15 RMII Signal Diagram

The KSZ8041NL RMII pin connections to the MAC are shown in [Figure 3-2](#).

FIGURE 3-2: KSZ8041NL RMII INTERFACE

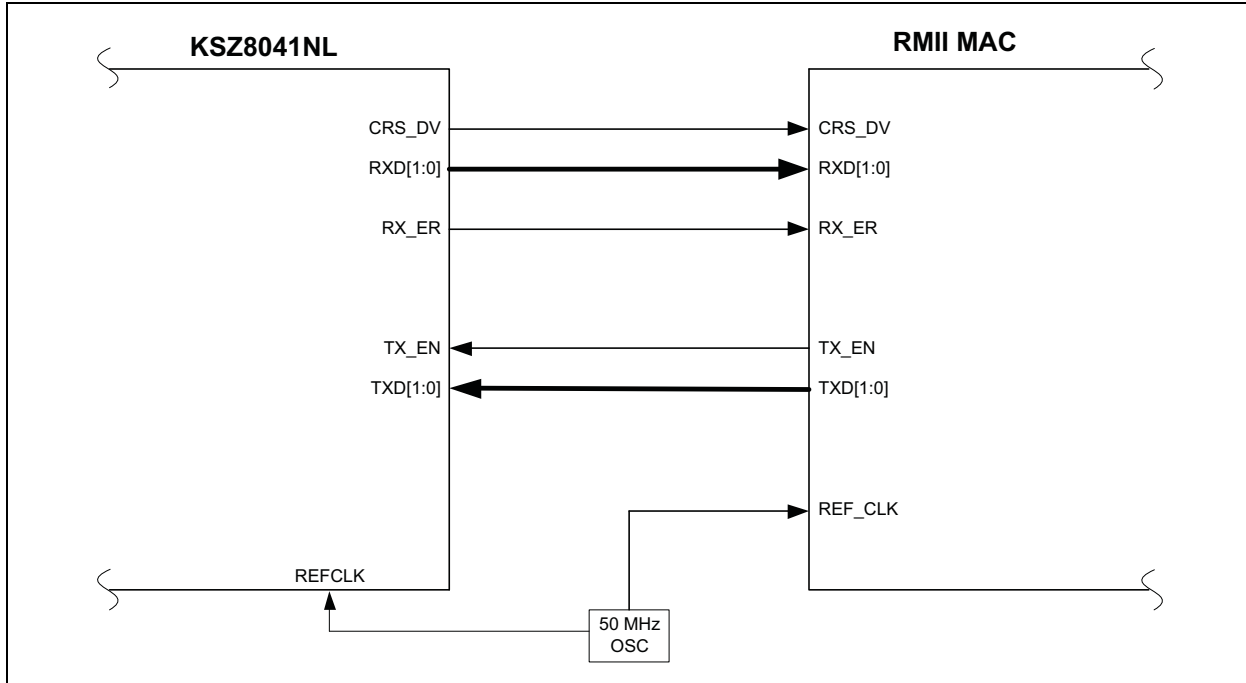
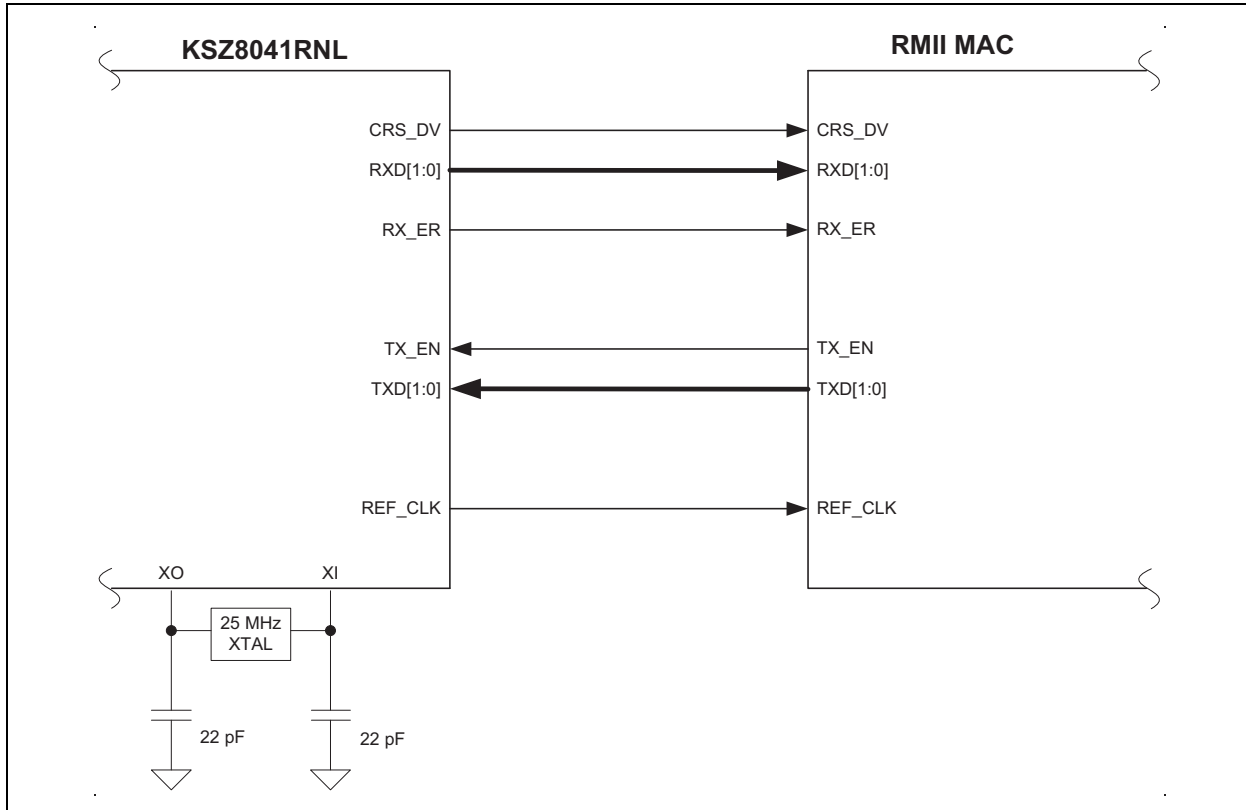

FIGURE 3-3: KSZ8041RNL RMII INTERFACE



3.16 HP Auto MDI/MDI-X

HP Auto MDI/MDI-X configuration eliminates the confusion of whether to use a straight cable or a crossover cable between the KSZ8041NL/RNL and its link partner. This feature allows the KSZ8041NL/RNL to use either type of cable to connect with a link partner that is in either MDI or MDI-X mode. The auto-sense function detects transmit and receive pairs from the link partner, and then assigns transmit and receive pairs of the KSZ8041NL/RNL accordingly.

HP Auto MDI/MDI-X is enabled by default. It is disabled by writing a one to register 1F bit 13. MDI and MDI-X mode is selected by register 1F bit 14 if HP Auto MDI/MDI-X is disabled.

An isolation transformer with symmetrical transmit and receive data paths is recommended to support auto MDI/MDI-X. The IEEE 802.3 Standard MDI and MDI-X is defined in [Table 3-5](#).

TABLE 3-5: MDI/MDI-X PIN DESCRIPTION

MDI		MDI-X	
RJ-45 Pin	Signal	RJ-45 Pin	Signal
1	TD+	1	RD+
2	TD-	2	RD-
3	RD+	3	TD+
6	RD-	6	TD-

KSZ8041NL/RNL

3.16.1 STRAIGHT CABLE

A straight cable connects a MDI device to a MDI-X device, or a MDI-X device to a MDI device. [Figure 3-4](#) depicts a typical straight cable connection between a NIC card (MDI) and a switch, or hub (MDI-X).

FIGURE 3-4: TYPICAL STRAIGHT CABLE CONNECTION

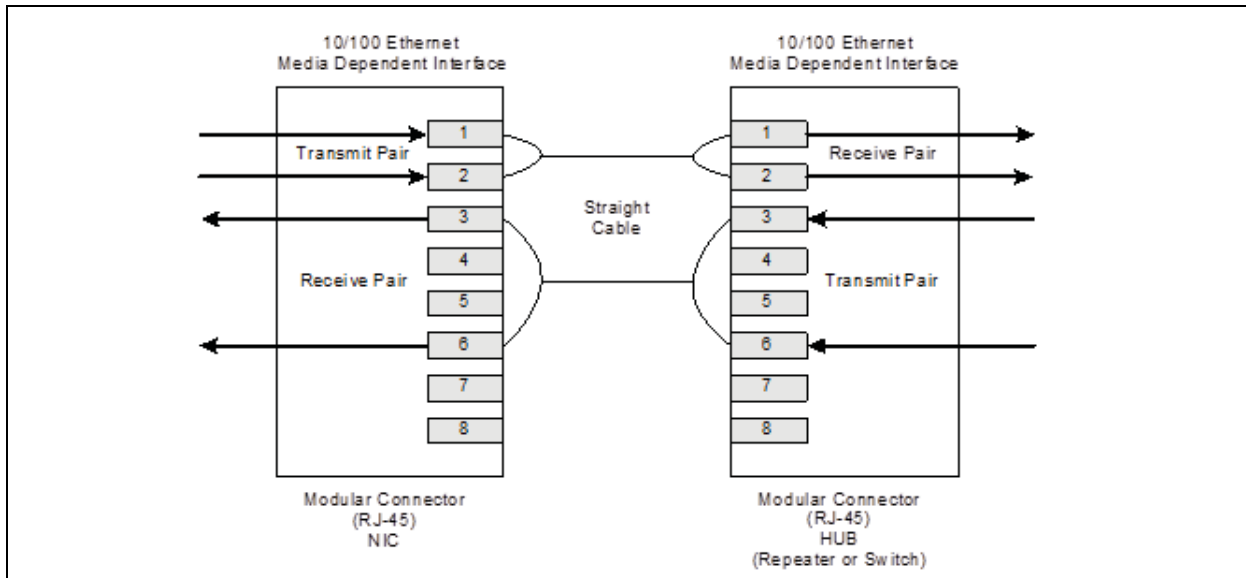

3.16.2 CROSSOVER CABLE

A crossover cable connects a MDI device to another MDI device, or a MDI-X device to another MDI-X device. [Table 3-4](#) depicts a typical crossover cable connection between two switches or hubs (two MDI-X devices).

FIGURE 3-5: TYPICAL CROSSOVER CABLE CONNECTION

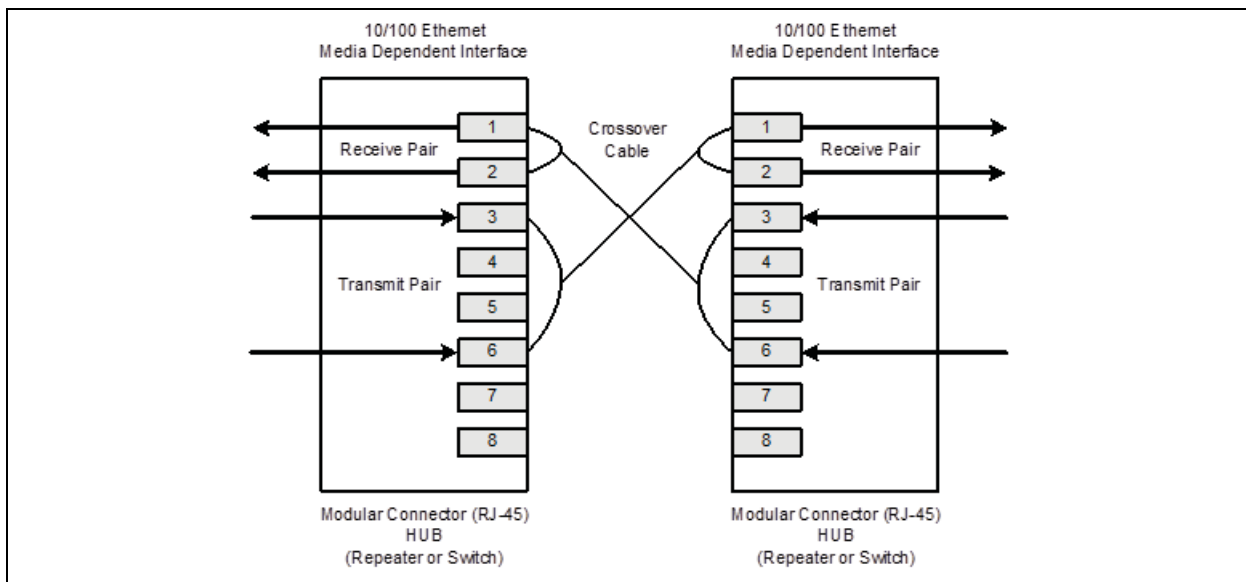

3.17 Power Management

The KSZ8041NL/RNL offers the following two power management modes:

- **Power Saving Mode**
This mode is used to reduce power consumption when the cable is unplugged. It is in effect when auto-negotiation mode is enabled, cable is disconnected, and register 1F bit 10 is set to 1. Under power saving mode, the KSZ8041NL/RNL shuts down all transceiver blocks, except for transmitter, energy detect and PLL circuits. Additionally, for the KSZ8041NL in MII mode, the RXC clock output is disabled. RXC clock is enabled after the cable is connected and link is established.
Power-saving mode is disabled by writing a zero to register 1F bit 10.
- **Power-Down Mode**
This mode is used to power down the entire KSZ8041NL/RNL device when it is not in use. Power down mode is enabled by writing a one to register 0 bit 11. In the power down state, the KSZ8041NL/RNL disables all internal functions, except for the MII management interface.

3.18 Reference Clock Connection Options

A crystal or clock source, such as an oscillator, is used to provide the reference clock for the KSZ8041NL/RNL.

Figure 3-6 illustrates how to connect the 25 MHz crystal and oscillator reference clock.

FIGURE 3-6: 25 MHz CRYSTAL/OSCILLATOR REFERENCE CLOCK

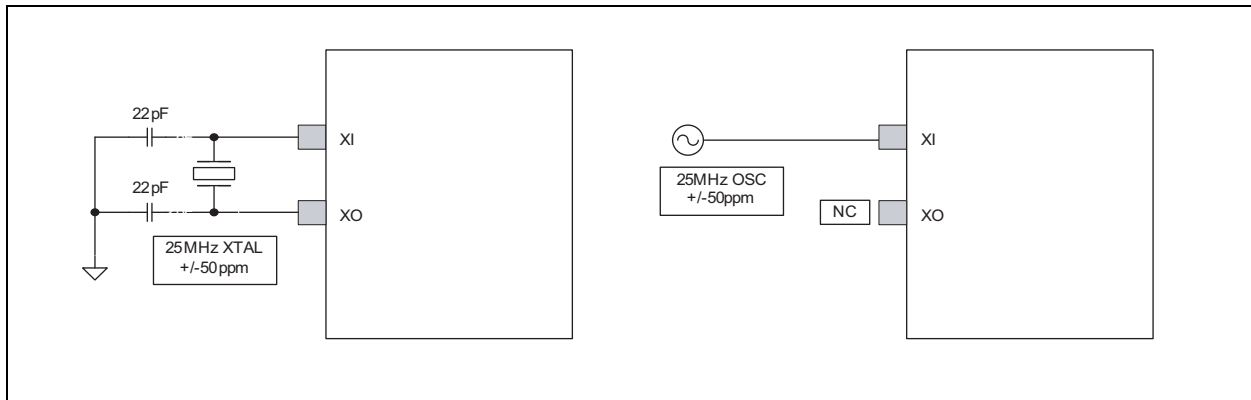

For the KSZ8041NL, Figure 3-7 illustrates how to connect the 50 MHz oscillator reference clock for RMII mode.

FIGURE 3-7: 50 MHz OSCILLATOR REFERENCE CLOCK FOR KSZ8041NL RMII MODE

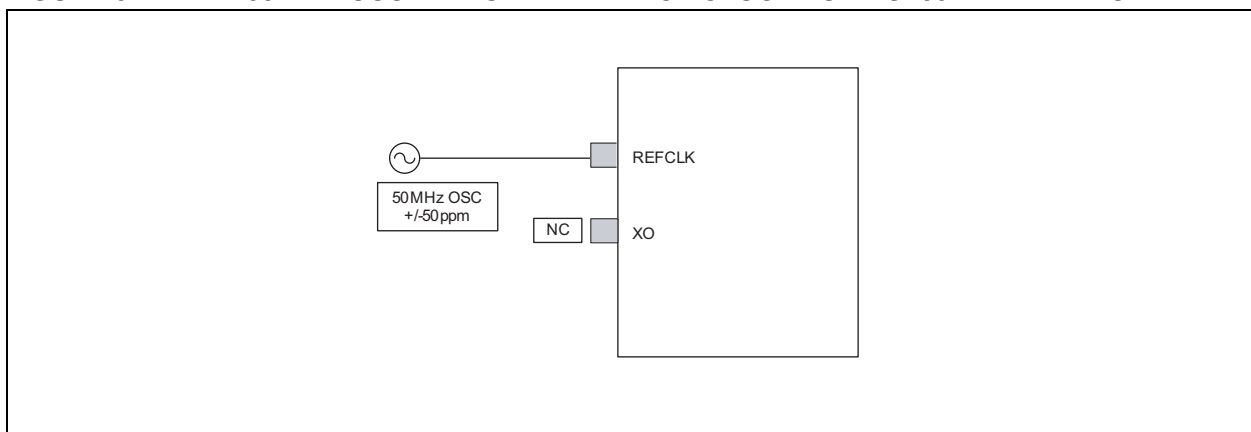

3.19 Reference Circuit for Power and Ground Connections

The KSZ8041NL/RNL is a single 3.3V supply device with a built-in 1.8V low-noise regulator. The power and ground connections are shown in Figure 3-8 and Table 3-6.

KSZ8041NL/RNL

FIGURE 3-8: KSZ8041NL/RNL POWER AND GROUND CONNECTIONS

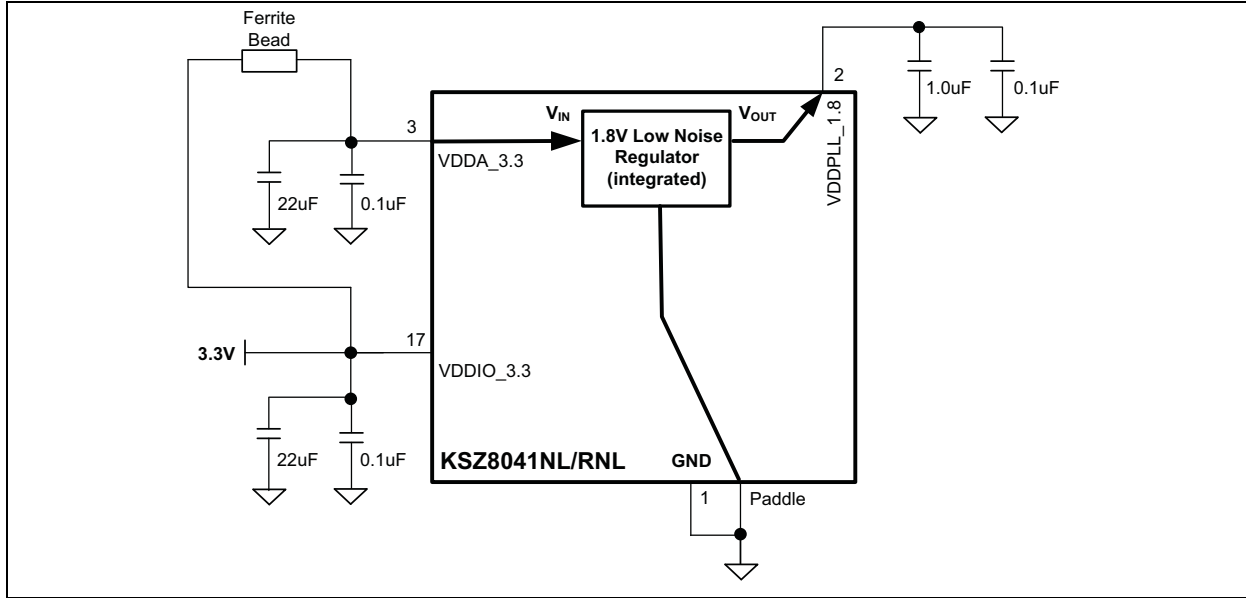

TABLE 3-6: KSZ8041NL/RNL POWER PIN DESCRIPTION

Power Pin	Pin Number	Description
VDDPLL_1.8	2	Decouple with 1.0 µF and 0.1 µF capacitors to ground.
VDDA_3.3	3	Connect to board's 3.3V supply through ferrite bead.
VDDIO_3.3	17	Connect to board's 3.3V supply.

4.0 REGISTERS

4.1 Register Map

Table 4-1 summarizes the register map.

TABLE 4-1: REGISTER MAP

Register Number (Hex)	Description
0h	Basic Control
1h	Basic Status
2h	PHY Identifier 1
3h	PHY Identifier 2
4h	Auto-Negotiation Advertisement
5h	Auto-Negotiation Link Partner Ability
6h	Auto-Negotiation Expansion
7h	Auto-Negotiation Next Page
8h	Link Partner Next Page Ability
9h – 13h	Reserved
14h	MII Control
15h	RXER Counter
16h – 1Ah	Reserved
1Bh	Interrupt Control/Status
1Ch – 1Dh	Reserved
1Eh	PHY Control 1
1Fh	PHY Control 2

KSZ8041NL/RNL

4.2 Register Descriptions

Table 4-2 provides a list of supported registers and their descriptions.

TABLE 4-2: REGISTER DESCRIPTIONS

Address	Name	Description	Mode (Note 4-1)	Default
Register 0h – Basic Control				
0.15	Reset	1 = Software reset 0 = Normal operation This bit is self-cleared after a '1' is written to it.	RW/SC	0
0.14	Loop-Back	1 = Loop-back mode 0 = Normal operation	RW	0
0.13	Speed Select (LSB)	1 = 100 Mbps 0 = 10 Mbps This bit is ignored if auto-negotiation is enabled (register 0.12 = 1).	RW	Set by SPEED strapping pin. See Table 2-2 and Table 2-4 for details.
0.12	Auto-Negotiation Enable	1 = Enable auto-negotiation process 0 = Disable auto-negotiation process If enabled, auto-negotiation result overrides settings in register 0.13 and 0.8.	RW	Set by NWAYEN strapping pin. See Table 2-2 and Table 2-4 for details.
0.11	Power Down	1 = Power-down mode 0 = Normal operation	RW	0
0.10	Isolate	1 = Electrical isolation of PHY from MII and TX+/TX- 0 = Normal operation	RW	Set by ISO strapping pin. See Table 2-2 and Table 2-4 for details.
0.9	Restart Auto-Negotiation	1 = Restart auto-negotiation process 0 = Normal operation. This bit is self-cleared after a '1' is written to it.	RW/SC	0
0.8	Duplex Mode	1 = Full-duplex 0 = Half-duplex	RW	Inverse of DUPLEX strapping pin value. See Table 2-2 and Table 2-4 for details.
0.7	Collision Test	1 = Enable COL test 0 = Disable COL test	RW	0
0.6:1	Reserved		RO	000_000
0.0	Disable Transmitter	0 = Enable transmitter 1 = Disable transmitter	RW	0
Register 1h – Basic Status				
1.15	100BASE-T4	1 = T4 capable 0 = Not T4 capable	RO	0
1.14	100BASE-TX Full Duplex	1 = Capable of 100 Mbps full-duplex 0 = Not capable of 100 Mbps full-duplex	RO	1

TABLE 4-2: REGISTER DESCRIPTIONS

Address	Name	Description	Mode (Note 4-1)	Default
1.13	100BASE-TX Half Duplex	1 = Capable of 100 Mbps half-duplex 0 = Not capable of 100 Mbps half-duplex	RO	1
1.12	10BASE-T Full Duplex	1 = Capable of 10 Mbps full-duplex 0 = Not capable of 10 Mbps full-duplex	RO	1
1.11	10BASE-T Half Duplex	1 = Capable of 10 Mbps half-duplex 0 = Not capable of 10 Mbps half-duplex	RO	1
1.10:7	Reserved	—	RO	0000
1.6	No Preamble	1 = Preamble suppression 0 = Normal preamble	RO	1
1.5	Auto-Negotiation Complete	1 = Auto-negotiation process completed 0 = Auto-negotiation process not completed	RO	0
1.4	Remote Fault	1 = Remote fault 0 = No remote fault	RO/LH	0
1.3	Auto-Negotiation Ability	1 = Capable to perform auto-negotiation 0 = Not capable to perform auto-negotiation	RO	1
1.2	Link Status	1 = Link is up 0 = Link is down	RO/LL	0
1.1	Jabber Detect	1 = Jabber detected 0 = Jabber not detected (default is low)	RO/LH	0
1.0	Extended Capability	1 = Supports extended capabilities registers	RO	1
Register 2h – PHY Identifier 1				
2.15:0	PHY ID Number	Assigned to the 3rd through 18th bits of the Organizationally Unique Identifier (OUI). Kendin Communication's OUI is 0010A1 (hex)	RO	0022h
Register 3h – PHY Identifier 2				
3.15:10	PHY ID Number	Assigned to the 19th through 24th bits of the Organizationally Unique Identifier (OUI). Kendin Communication's OUI is 0010A1 (hex)	RO	0001_01
3.9:4	Model Number	Six bit manufacturer's model number	RO	01_0001
3.3:0	Revision Number	Four bit manufacturer's revision number	RO	Indicates silicon revision

KSZ8041NL/RNL

TABLE 4-2: REGISTER DESCRIPTIONS

Address	Name	Description	Mode (Note 4-1)	Default
Register 4h – Auto-Negotiation Advertisement				
4.15	Next Page	1 = Next page capable 0 = No next page capability.	RW	0
4.14	Reserved		RO	0
4.13	Remote Fault	1 = Remote fault supported 0 = No remote fault	RW	0
4.12	Reserved		RO	0
4.11:10	Pause	[00] = No PAUSE [10] = Asymmetric PAUSE [01] = Symmetric PAUSE [11] = Asymmetric & Symmetric PAUSE	RW	00
4.9	100BASE-T4	1 = T4 capable 0 = No T4 capability	RO	0
4.8	100BASE-TX Full-Duplex	1 = 100 Mbps full-duplex capable 0 = No 100 Mbps full-duplex capability	RW	Set by SPEED strapping pin. See Table 2-2 and Table 2-4 for details.
4.7	100BASE-TX Half-Duplex	1 = 100 Mbps half-duplex capable 0 = No 100 Mbps half-duplex capability	RW	Set by SPEED strapping pin. See Table 2-2 and Table 2-4 for details.
4.6	10BASE-T Full-Duplex	1 = 10 Mbps full-duplex capable 0 = No 10 Mbps full-duplex capability	RW	1
4.5	10BASE-T Half-Duplex	1 = 10 Mbps half-duplex capable 0 = No 10 Mbps half-duplex capability	RW	1
4.4:0	Selector Field	[00001] = IEEE 802.3	RW	0_0001
Register 5h – Auto-Negotiation Link Partner Ability				
5.15	Next Page	1 = Next page capable 0 = No next page capability	RO	0
5.14	Acknowledge	1 = Link code word received from partner 0 = Link code word not yet received	RO	0
5.13	Remote Fault	1 = Remote fault detected 0 = No remote fault	RO	0
5.12	Reserved	—	RO	0
5.11:10	Pause	[00] = No PAUSE [10] = Asymmetric PAUSE [01] = Symmetric PAUSE [11] = Asymmetric & Symmetric PAUSE	RO	00
5.9	100BASE-T4	1 = T4 capable 0 = No T4 capability	RO	0

TABLE 4-2: REGISTER DESCRIPTIONS

Address	Name	Description	Mode (Note 4-1)	Default
5.8	100BASE-TX Full-Duplex	1 = 100 Mbps full-duplex capable 0 = No 100 Mbps full-duplex capability	RO	0
5.7	100BASE-TX Half-Duplex	1 = 100 Mbps half-duplex capable 0 = No 100 Mbps half-duplex capability	RO	0
5.6	10BASE-T Full-Duplex	1 = 10 Mbps full-duplex capable 0 = No 10 Mbps full-duplex capability	RO	0
5.5	10BASE-T Half-Duplex	1 = 10 Mbps half-duplex capable 0 = No 10 Mbps half-duplex capability	RO	0
5.4:0	Selector Field	[00001] = IEEE 802.3	RO	0_0001
Register 6h – Auto-Negotiation Expansion				
6.15:5	Reserved		RO	0000_0000_000
6.4	Parallel Detection Fault	1 = Fault detected by parallel detection 0 = No fault detected by parallel detection.	RO/LH	0
6.3	Link Partner Next Page Able	1 = Link partner has next page capability 0 = Link partner does not have next page capability	RO	0
6.2	Next Page Able	1 = Local device has next page capability 0 = Local device does not have next page capability	RO	1
6.1	Page Received	1 = New page received 0 = New page not received yet	RO/LH	0
6.0	Link Partner Auto-Negotiation Able	1 = Link partner has auto-negotiation capability 0 = Link partner does not have auto-negotiation capability	RO	0
Register 7h – Auto-Negotiation Next Page				
7.15	Next Page	1 = Additional next page(s) will follow 0 = Last page	RW	0
7.14	Reserved	—	RO	0
7.13	Message Page	1 = Message page 0 = Unformatted page	RW	1
7.12	Acknowledge2	1 = Will comply with message 0 = Cannot comply with message	RW	0

KSZ8041NL/RNL

TABLE 4-2: REGISTER DESCRIPTIONS

Address	Name	Description	Mode (Note 4-1)	Default
7.11	Toggle	1 = Previous value of the transmitted link code word equaled logic one 0 = Logic zero	RO	0
7.10:0	Message Field	11-bit wide field to encode 2048 messages	RW	000_0000_0001
Register 8h – Link Partner Next Page Ability				
8.15	Next Page	1 = Additional Next Page(s) will follow 0 = Last page	RO	0
8.14	Acknowledge	1 = Successful receipt of link word 0 = No successful receipt of link word	RO	0
8.13	Message Page	1 = Message page 0 = Unformatted page	RO	0
8.12	Acknowledge2	1 = Able to act on the information 0 = Not able to act on the information	RO	0
8.11	Toggle	1 = Previous value of transmitted link code word equal to logic zero 0 = Previous value of transmitted link code word equal to logic one	RO	0
8.10:0	Message Field	—	RO	000_0000_0000
Register 14h – MII Control				
14.15:8	Reserved	—	RO	0000_0000
14.7	100BASE-TX Preamble Restore	1 = Restore received preamble to MII output (random latency) 0 = Consume 1-byte preamble before sending frame to MII output for fixed latency	RW	0 or 1 (if CONFIG[2:0] = 100) See Table 2-2 and Table 2-4 for details.
14.6	10BASE-T Preamble Restore	1 = Restore received preamble to MII output 0 = Remove all 7-bytes of preamble before sending frame (starting with SFD) to MII output	RW	0
14.5:0	Reserved	—	RO	00_0001
Register 15h – RXER Counter				
15.15:0	RXER Counter	Receive error counter for Symbol Error frames	RO/SC	000h
Register 1Bh – Interrupt Control/Status				
1b.15	Jabber Interrupt Enable	1 = Enable Jabber Interrupt 0 = Disable Jabber Interrupt	RW	0

TABLE 4-2: REGISTER DESCRIPTIONS

Address	Name	Description	Mode (Note 4-1)	Default
1b.14	Receive Error Interrupt Enable	1 = Enable Receive Error Interrupt 0 = Disable Receive Error Interrupt	RW	0
1b.13	Page Received Interrupt Enable	1 = Enable Page Received Interrupt 0 = Disable Page Received Interrupt	RW	0
1b.12	Parallel Detect Fault Interrupt Enable	1 = Enable Parallel Detect Fault Interrupt 0 = Disable Parallel Detect Fault Interrupt	RW	0
1b.11	Link Partner Acknowledge Interrupt Enable	1 = Enable Link Partner Acknowledge Interrupt 0 = Disable Link Partner Acknowledge Interrupt	RW	0
1b.10	Link Down Interrupt Enable	1 = Enable Link Down Interrupt 0 = Disable Link Down Interrupt	RW	0
1b.9	Remote Fault Interrupt Enable	1 = Enable Remote Fault Interrupt 0 = Disable Remote Fault Interrupt	RW	0
1b.8	Link Up Interrupt Enable	1 = Enable Link Up Interrupt 0 = Disable Link Up Interrupt	RW	0
1b.7	Jabber Interrupt	1 = Jabber occurred 0 = Jabber did not occurred	RO/SC	0
1b.6	Receive Error Interrupt	1 = Receive Error occurred 0 = Receive Error did not occurred	RO/SC	0
1b.5	Page Receive Interrupt	1 = Page Receive occurred 0 = Page Receive did not occurred	RO/SC	0
1b.4	Parallel Detect Fault Interrupt	1 = Parallel Detect Fault occurred 0 = Parallel Detect Fault did not occurred	RO/SC	0
1b.3	Link Partner Acknowledge Interrupt	1 = Link Partner Acknowledge occurred 0 = Link Partner Acknowledge did not occurred	RO/SC	0
1b.2	Link Down Interrupt	1 = Link Down occurred 0 = Link Down did not occurred	RO/SC	0
1b.1	Remote Fault Interrupt	1 = Remote Fault occurred 0 = Remote Fault did not occurred	RO/SC	0
1b.0	Link Up Interrupt	1 = Link Up occurred 0 = Link Up did not occurred	RO/SC	0

KSZ8041NL/RNL

TABLE 4-2: REGISTER DESCRIPTIONS

Address	Name	Description	Mode (Note 4-1)	Default
Register 1Eh – PHY Control 1				
1e:15:14	LED mode	[00] = LED1 : Speed LED0 : Link/Activity [01] = LED1 : Activity LED0 : Link [10], [11] = Reserved	RW	00
1e:13	Polarity	0 = Polarity is not reversed 1 = Polarity is reversed	RO	—
1e:12	Reserved	—	RO	0
1e:11	MDI/MDI-X State	0 = MDI 1 = MDI-X	RO	—
1e:10:8	Reserved	—	—	—
1e:7	Remote loopback	0 = Normal mode 1 = Remote (analog) loop back is enable	RW	0
1e:6:0	Reserved	—	—	—
Register 1Fh – PHY Control 2				
1f:15	HP_MDIX	0 = Auto MDI/MDI-X mode 1 = HP Auto MDI/MDI-X mode	RW	1
1f:14	MDI/MDI-X Select	When Auto MDI/MDI-X is disabled, 0 = MDI Mode Transmit on TX+/- (pins 7, 6) and Receive on RX+/- (pins 5, 4) 1 = MDI-X Mode Transmit on RX+/- (pins 5,4) and Receive on TX+/- (pins 7, 6)	RW	0
1f:13	Pair Swap Disable	1 = Disable auto MDI/MDI-X 0 = Enable auto MDI/MDI-X	RW	0
1f:12	Energy Detect	1 = Presence of signal on RX+/- analog wire pair 0 = No signal detected on RX+/-	RO	0
1f:11	Force Link	1 = Force link pass 0 = Normal link operation This bit bypasses the control logic and allow transmitter to send pattern even if there is no link.	RW	0

TABLE 4-2: REGISTER DESCRIPTIONS

Address	Name	Description	Mode (Note 4-1)	Default
Register 1Fh – PHY Control 2 (Continued)				
1f.10	Power Saving	1 = Enable power saving 0 = Disable power saving If power saving mode is enabled and the cable is disconnected, the RXC clock output (in MII mode) is disabled. RXC clock is enabled after the cable is connected and link is established.	RW	0
1f.9	Interrupt Level	1 = Interrupt pin active high 0 = Interrupt pin active low	RW	0
1f.8	Enable Jabber	1 = Enable jabber counter 0 = Disable jabber counter	RW	1
1f.7	Auto-Negotiation Complete	1 = Auto-negotiation process completed 0 = Auto-negotiation process not completed	RW	0
1f.6	Enable Pause (Flow Control)	1 = Flow control capable 0 = No flow control capability	RO	0
1f.5	PHY Isolate	1 = PHY in isolate mode 0 = PHY in normal operation	RO	0
1f.4:2	Operation Mode Indication	[000] = still in auto-negotiation [001] = 10 BASE-T half-duplex [010] = 100 BASE-TX half-duplex [011] = reserved [101] = 10 BASE-T full-duplex [110] = 100 BASE-TX full-duplex [111] = reserved	RO	000
1f.1	Enable SQE test	1 = Enable SQE test 0 = Disable SQE test	RW	0
1f.0	Disable Data Scrambling	1 = Disable scrambler 0 = Enable scrambler	RW	0

Note 4-1 RW = Read/Write.
RO = Read only.
SC = Self-cleared.
LH = Latch high.
LL = Latch low.

KSZ8041NL/RNL

5.0 OPERATIONAL CHARACTERISTICS

5.1 Absolute Maximum Ratings (Note 5-1)

Supply Voltage ($V_{DDPLL_1.8}$).....	-0.5V to +2.4V
Supply Voltage ($V_{DDPLL_3.3}$, $V_{DDPLL_3.3}$)	-0.5V to +4.0V
Input Voltage (all inputs).....	-0.5V to +4.0V
Output Voltage (all outputs).....	-0.5V to +4.0V
Storage Temperature (T_S).....	-55°C to +150°C
ESD Performance Rating (Note 5-2).....	+6 kV

5.2 Operating Ratings (Note 5-3)

Supply Voltage ($V_{DDIO_3.3}$, $V_{DDA_3.3}$).....	+3.135V to +3.465V
Ambient Temperature	
(T_A , Commercial).....	0°C to +70°C
(T_A , Industrial).....	-40°C to +85°C
(T_A , Automotive Qualified).....	-40°C to +85°C
Maximum Junction Temperature (T_J maximum)	+125°C
Thermal Resistance (θ_{JA}).....	34°C/W
Thermal Resistance (θ_{JC}).....	6°C/W

Note 5-1 Exceeding the absolute maximum rating may damage the device. Stresses greater than the absolute maximum rating may cause permanent damage to the device. Operation of the device at these or any other conditions above those specified in the operating sections of this specification is not implied. Maximum conditions for extended periods may affect reliability.

Note 5-2 Devices are ESD sensitive. Handling precautions recommended. Human body model, 1.5 k Ω in series with 100 pF.

Note 5-3 The device is not guaranteed to function outside its operating rating.

6.0 ELECTRICAL CHARACTERISTICS (Note 6-1, Note 6-2)

Symbol	Parameter	Condition	Min.	Typ.	Max.	Units
Supply Current						
I_{DD1}	100BASE-TX	Chip only (no transformer); Full-duplex traffic @ 100% utilization	—	53.0	—	mA
I_{DD2}	10BASE-T	Chip only (no transformer); Full-duplex traffic @ 100% utilization	—	38.0	—	mA
I_{DD3}	Power-Saving Mode	Ethernet cable disconnected (reg. 1F.10 = 1)	—	32.0	—	mA
I_{DD4}	Power-Down Mode	Software power-down (reg. 0.11 = 1)	—	4.0	—	mA
TTL Inputs						
V_{IH}	Input High Voltage	—	2.0	—	—	V
V_{IL}	Input Low Voltage	—	—	—	0.8	V
I_{IN}	Input Current	$V_{IN} = \text{GND} \sim \text{VDDIO}$	—	-10	10	μA
TTL Outputs						
V_{OH}	Output High Voltage	$I_{OH} = -4 \text{ mA}$	2.4	—	—	V
V_{OL}	Output Low Voltage	$I_{OL} = 4 \text{ mA}$	—	—	0.4	V
$ I_{OZ} $	Output Tri-State Leakage	—	—	—	10	μA
LED Outputs						
I_{LED}	Output Drive Current	Each LED pin (LED0, LED1)	—	8	—	mA
100BASE-TX Transmit (measured differentially after 1:1 transformer)						
V_O	Peak Differential Output Voltage	100 Ω termination across differential output	0.95	—	1.05	V
V_{IMB}	Output Voltage Imbalance	100 Ω termination across differential output	—	—	2	%
t_r, t_f	Rise/Fall Time	—	3	—	5	ns
	Rise/Fall Time Imbalance	—	0	—	0.5	ns
	Duty Cycle Distortion	—	—	—	± 0.25	ns
	Overshoot	—	—	—	5	%
V_{SET}	Reference Voltage of ISET	—	—	0.65	—	V
—	Output Jitter	Peak-to-peak	—	0.7	1.4	ns
10BASE-T Transmit (measured differentially after 1:1 transformer)						
V_P	Peak Differential Output Voltage	100 Ω termination across differential output	2.2	—	2.8	V
—	Jitter Added	Peak-to-peak	—	—	3.5	ns
t_r, t_f	Rise/Fall Time	—	—	25	—	ns
10BASE-T Receive						
V_{SQ}	Squelch Threshold	5 MHz square wave	—	400	—	mV

Note 6-1 Current consumption is for the single 3.3V supply KSZ8041NL/RNL device only, and includes the 1.8V supply voltage (VDDPLL_1.8) that is provided by the KSZ8041NL/RNL. The PHY port's transformer consumes an additional 45 mA @ 3.3V for 100BASE-TX and 70 mA @ 3.3V for 10BASE-T.

Note 6-2 $T_A = 25^\circ\text{C}$. Specification for packaged product only.

KSZ8041NL/RNL

7.0 TIMING DIAGRAMS

7.1 MII SQE Timing

FIGURE 7-1: MII SQE TIMING (10BASE-T)

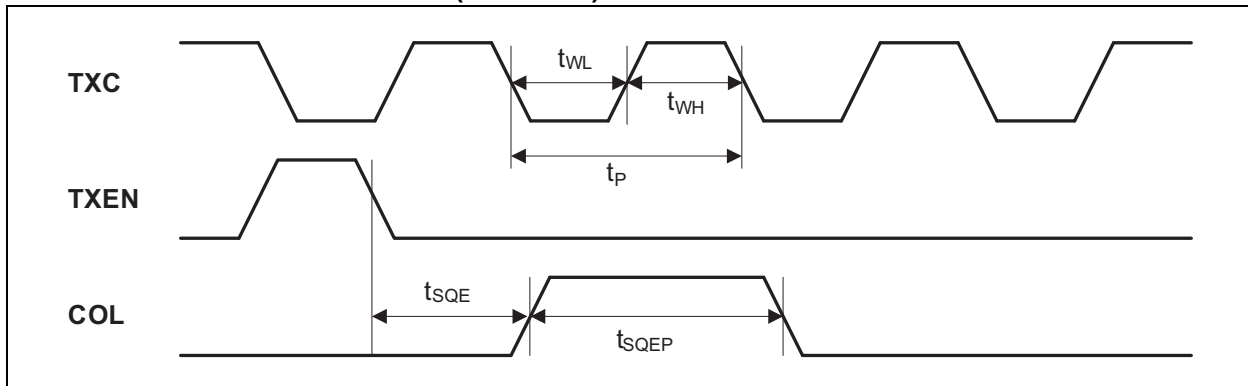

TABLE 7-1: MII SQE TIMING (10BASE-T) PARAMETERS

Timing Parameter	Description	Min.	Typ.	Max.	Unit
t_P	TXC Period	—	400	—	ns
t_{WL}	TXC Pulse Width Low	—	200	—	ns
t_{WH}	TXC Pulse Width High	—	200	—	ns
t_{SQE}	COL (SQE) Delay After TXEN De-Asserted	—	2.5	—	us
t_{SQEP}	COL (SQE) Pulse Duration	—	1.0	—	us

7.2 MII Transmit Timing (10BASE-T)

FIGURE 7-2: MII TRANSMIT TIMING (10BASE-T)

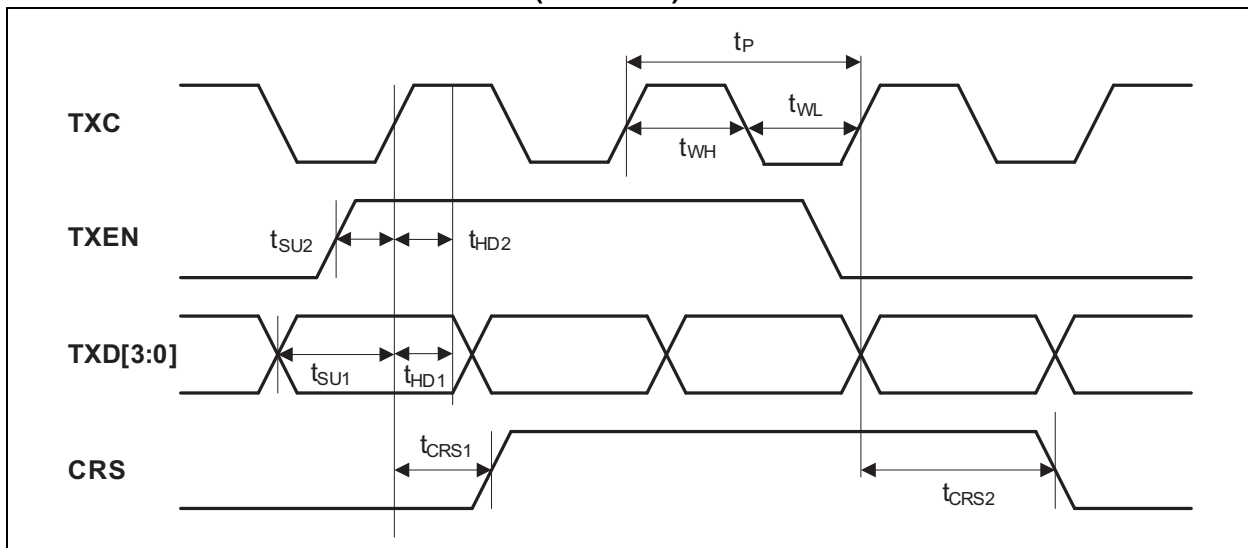

TABLE 7-2: MII TRANSMIT TIMING (10BASE-T) PARAMETERS

Timing Parameter	Description	Min.	Typ.	Max.	Units
t_p	TXC Period	—	400	—	ns
t_{WL}	TXC Pulse Width Low	—	200	—	ns
t_{WH}	TXC Pulse Width High	—	200	—	ns
t_{SU1}	TXD[3:0] Setup to Rising Edge of TXC	10	—	—	ns
t_{SU2}	TXEN Setup to Rising Edge of TXC	10	—	—	ns
t_{HD1}	TXD[3:0] Hold from Rising Edge of TXC	0	—	—	ns
t_{HD2}	TXEN Hold from Rising Edge of TXC	0	—	—	ns
t_{CRS1}	TXEN High to CRS Asserted Latency	—	160	—	ns
t_{CRS2}	TXEN Low to CRS De-Asserted Latency	—	510	—	ns

7.3 MII Receive Timing (10BASE-T)

FIGURE 7-3: MII RECEIVE TIMING (10BASE-T)

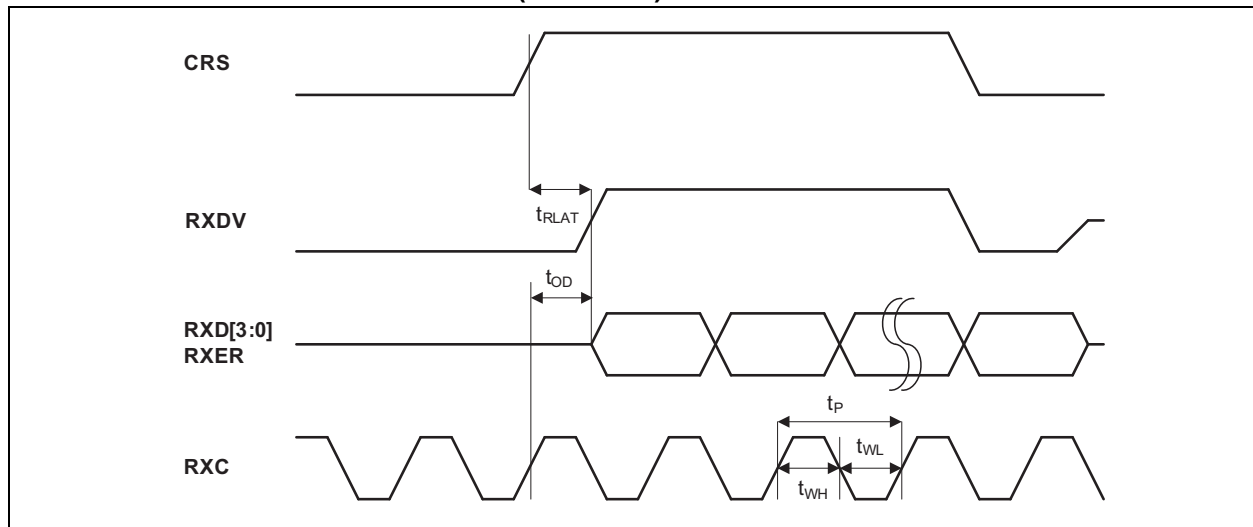

TABLE 7-3: MII RECEIVE TIMING (10BASE-T) PARAMETERS

Timing Parameter	Description	Min.	Typ.	Max.	Unit
t_p	RXC Period	—	400	—	ns
t_{WL}	RXC Pulse Width Low	—	200	—	ns
t_{WH}	RXC Pulse Width High	—	200	—	ns
t_{OD}	(RXD[3:0], RXER, RXDV) Output Delay from Rising Edge of RXC	182	—	225	ns
t_{RLAT}	CRS to (RXD[3:0], RXER, RXDV) Latency	—	6.5	—	μ s

KSZ8041NL/RNL

7.4 MII Transmit Timing (100BASE-TX)

FIGURE 7-4: MII TRANSMIT TIMING (100BASE-TX)

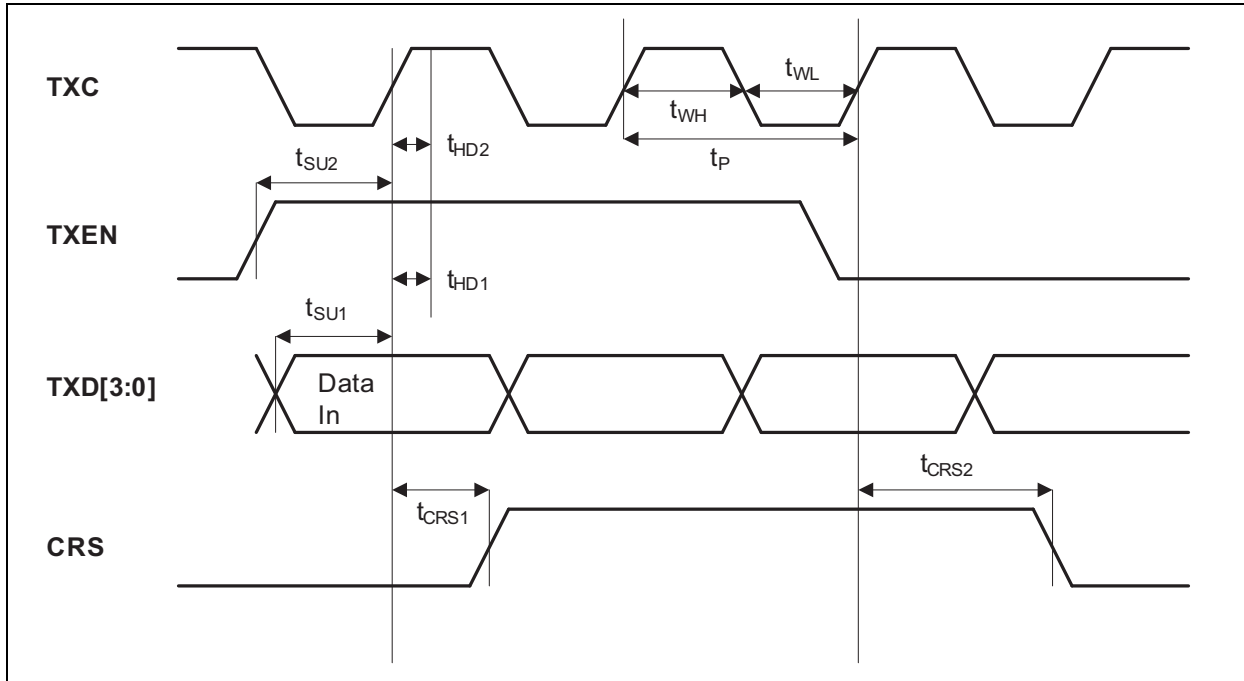

TABLE 7-4: MII TRANSMIT TIMING (100BASE-TX) PARAMETERS

Timing Parameter	Description	Min.	Typ.	Max.	Unit
t_p	TXC Period	—	40	—	ns
t_{WL}	TXC Pulse Width Low	—	20	—	ns
t_{WH}	TXC Pulse Width High	—	20	—	ns
t_{SU1}	TXD[3:0] Setup to Rising Edge of TXC	10	—	—	ns
t_{SU2}	TXEN Setup to Rising Edge of TXC	10	—	—	ns
t_{HD1}	TXD[3:0] Hold from Rising Edge of TXC	0	—	—	ns
t_{HD2}	TXEN Hold from Rising Edge of TXC	0	—	—	ns
t_{CRS1}	TXEN High to CRS Asserted Latency	—	34	—	ns
t_{CRS2}	TXEN Low to CRS De-Asserted Latency	—	33	—	ns

7.5 MII Receive Timing (100BASE-TX)

FIGURE 7-5: MII RECEIVE TIMING (100BASE-TX)

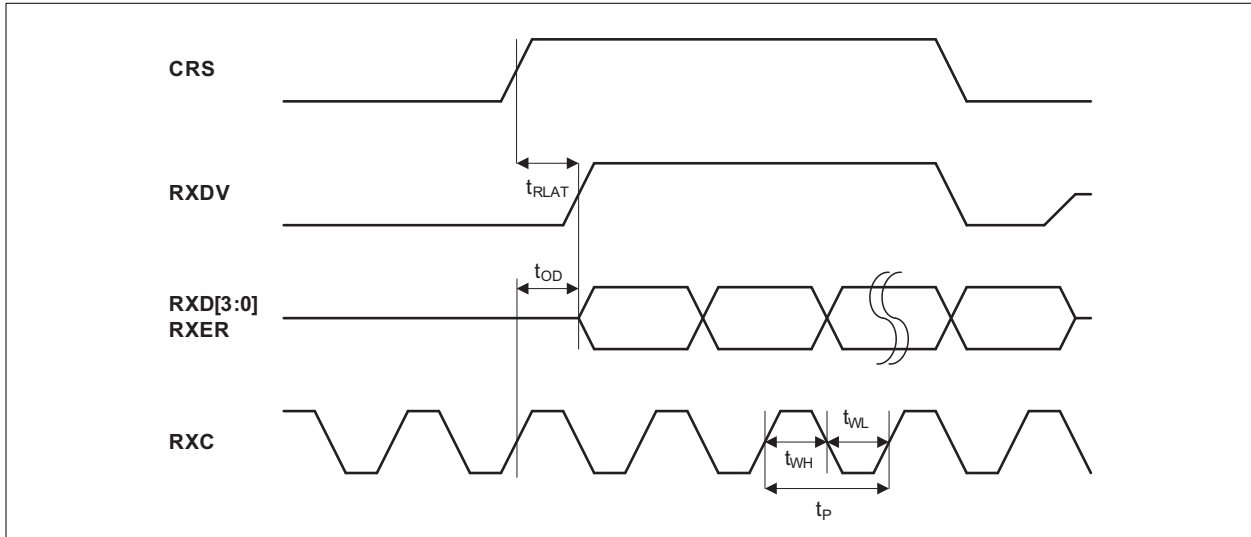

TABLE 7-5: MII RECEIVE TIMING (100BASE-TX) PARAMETERS

Timing Parameter	Description	Min.	Typ	Max.	Units
t_p	RXC Period	—	40	—	ns
t_{WL}	RXC Pulse Width Low	—	20	—	ns
t_{WH}	RXC Pulse Width High	—	20	—	ns
t_{OD}	(RXD[3:0], RXER, RXDV) Output Delay from Rising Edge of RXC	19	—	25	ns
t_{RLAT}	CRS to RXDV Latency	—	140	—	ns
	CRS to RXD[3:0] Latency	—	52	—	ns
	CRS to RXER Latency	—	60	—	ns

KSZ8041NL/RNL

7.6 RMI Timing

FIGURE 7-6: RMI TIMING – DATA RECEIVED FROM RMI

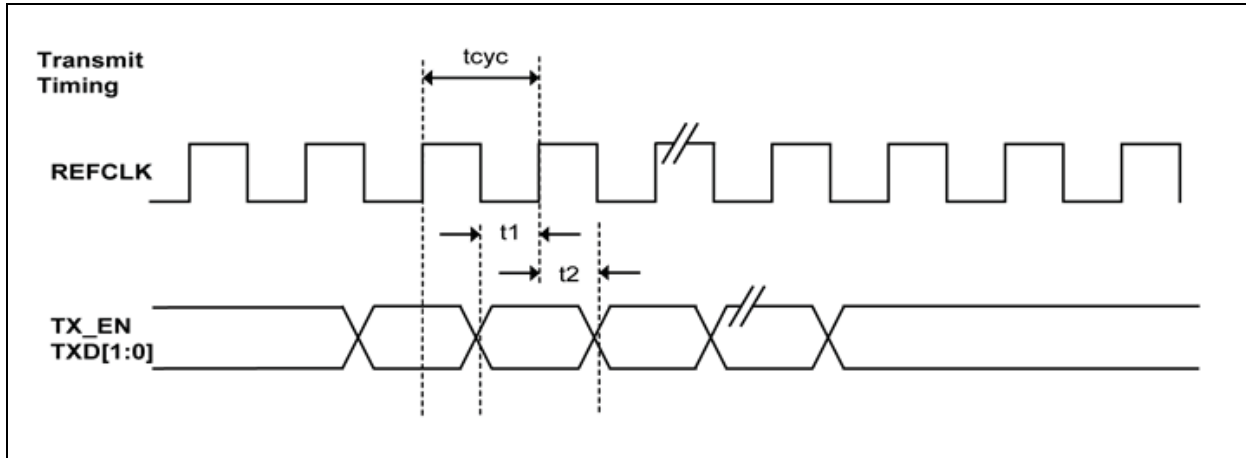

FIGURE 7-7: RMI TIMING – DATA INPUT TO RMI

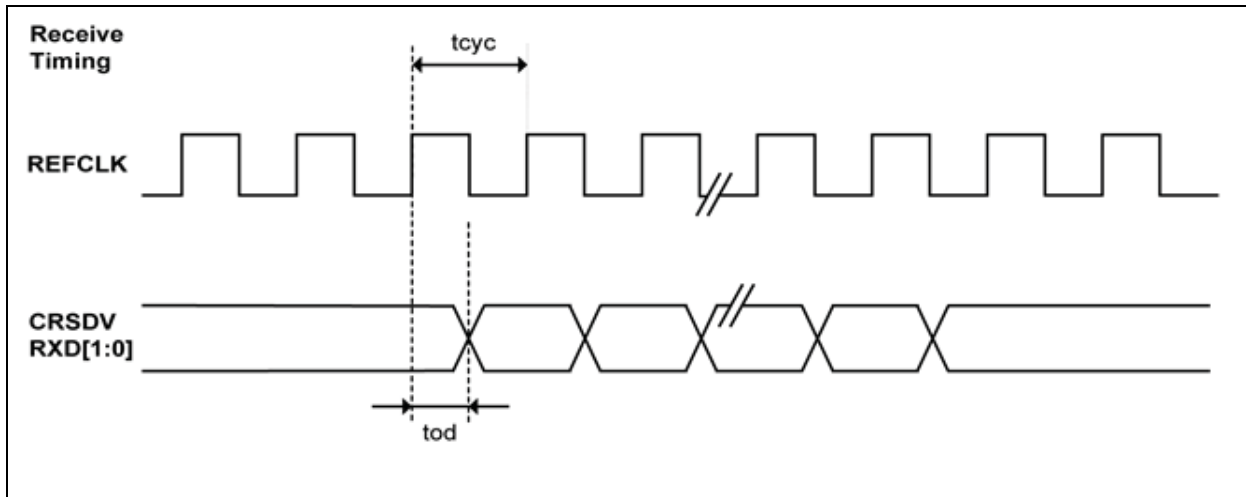

TABLE 7-6: RMI TIMING PARAMETERS – KSZ8041NL

Timing Parameter	Description	Min.	Typ	Max.	Units
t_{cyc}	Clock Cycle	—	20	—	ns
t_1	Setup Time	4	—	—	ns
t_2	Hold Time	2	—	—	ns
t_{od}	Output Delay	3	—	9	ns

TABLE 7-7: RMI TIMING PARAMETERS – KSZ8041RNL

Timing Parameter	Description	Min.	Typ	Max.	Units
t_{cyc}	Clock Cycle	—	20	—	ns
t_1	Setup Time	4	—	—	ns
t_2	Hold Time	1	—	—	ns
t_{od}	Output Delay	9	11	13	ns

7.7 Auto-Negotiation Timing

FIGURE 7-8: AUTO-NEGOTIATION FAST LINK PULSE (FLP) TIMING

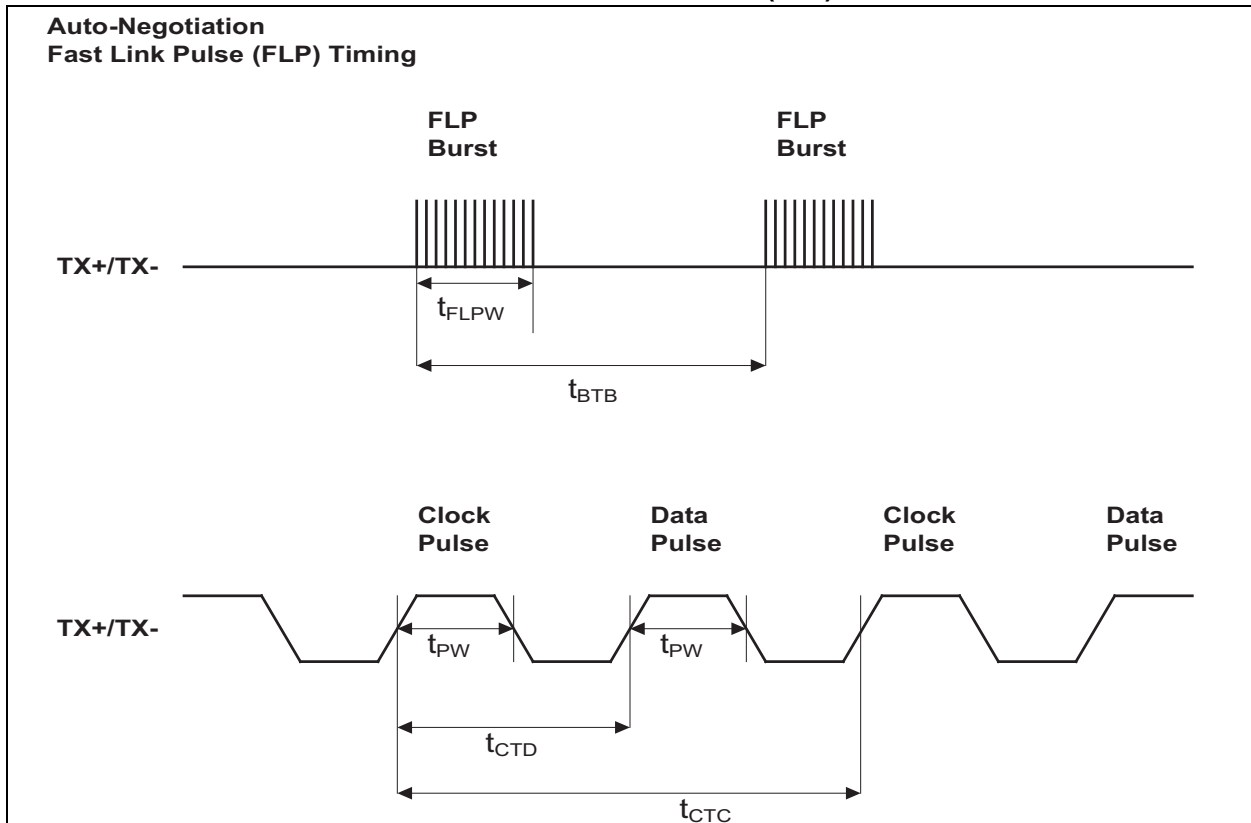

TABLE 7-8: AUTO-NEGOTIATION FAST LINK PULSE (FLP) TIMING PARAMETERS

Timing Parameter	Description	Min.	Typ	Max.	Units
t_{BTB}	FLP Burst to FLP Burst	8	16	24	ms
t_{FLPW}	FLP Burst Width	—	2	—	ms
t_{PW}	Clock/Data Pulse Width	—	100	—	ns
t_{CTD}	Clock Pulse to Data Pulse	55.5	64	69.5	μ s
t_{CTC}	Clock Pulse to Clock Pulse	111	128	139	μ s
—	Number of Clock/Data Pulse per FLP Burst	17	—	33	—

KSZ8041NL/RNL

7.8 MDC/MDIO Timing

FIGURE 7-9: MDC/MDIO TIMING

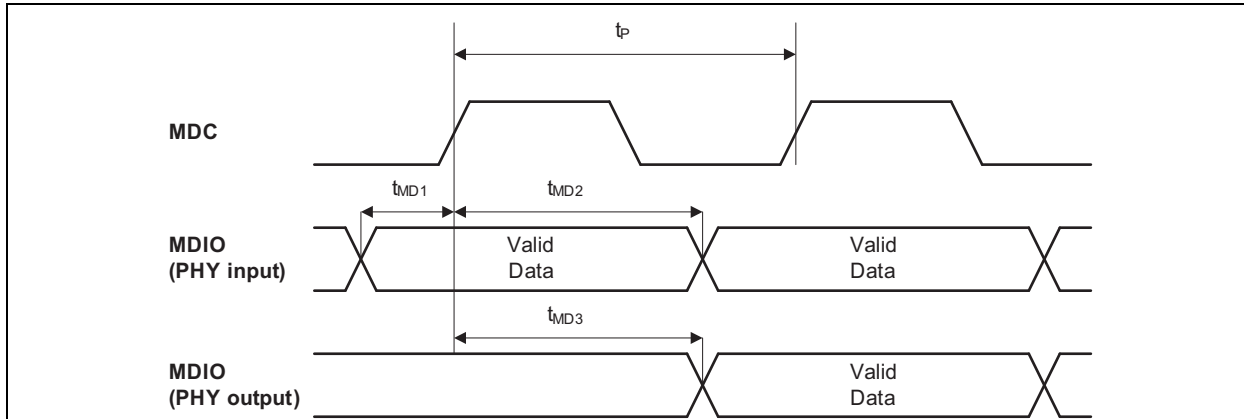

TABLE 7-9: MDC/MDIO TIMING PARAMETERS

Timing Parameter	Description	Min.	Typ.	Max.	Unit
t_p	MDC Period	—	400	—	ns
t_{1MD1}	MDIO (PHY Input) Setup to Rising Edge of MDC	10	—	—	ns
t_{MD2}	MDIO (PHY Input) Hold from Rising Edge of MDC	4	—	—	ns
t_{MD3}	MDIO (PHY Output) Delay from Rising Edge of MDC	—	222	—	ns

7.9 Power-Up/Reset Timing

The KSZ8041NL/RNL reset timing requirement is summarized in [Figure 7-10](#) and [Figure 7-10](#).

FIGURE 7-10: POWER-UP/RESET TIMING

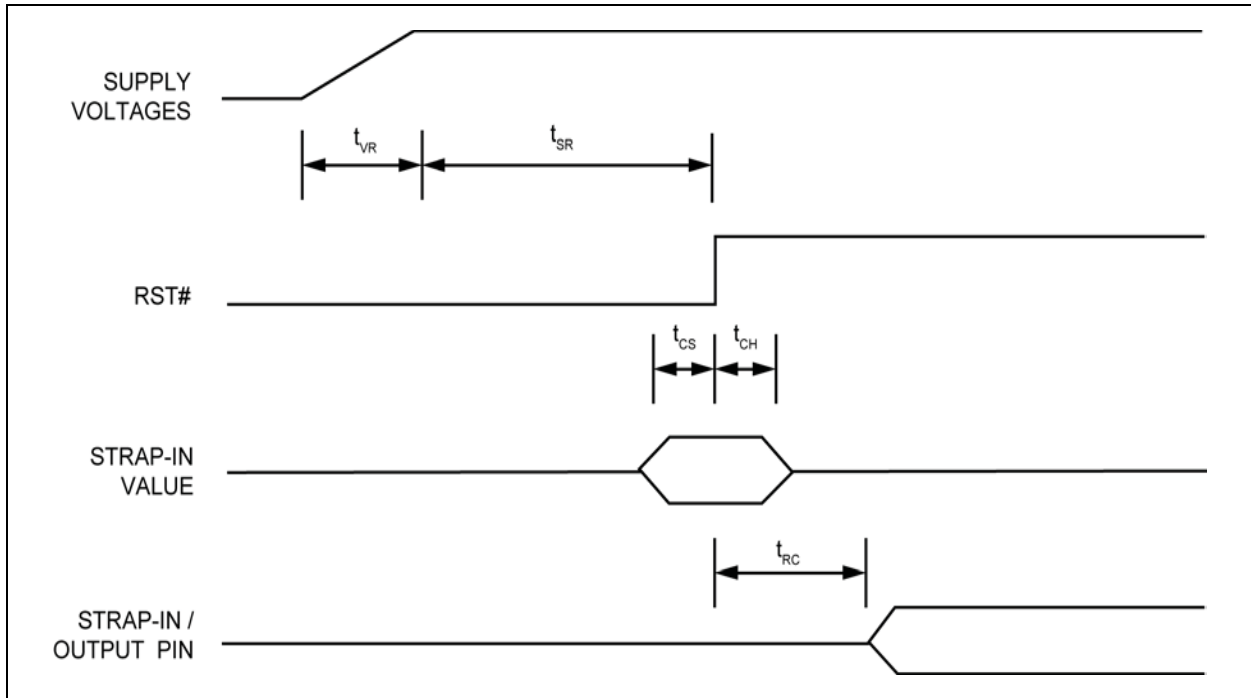

TABLE 7-10: POWER-UP/RESET TIMING PARAMETERS

Parameters	Description	Min	Max	Units
t_{VR}	Supply Voltage ($V_{DDIO_3.3}$, $V_{DDA_3.3}$) Rise Time	250	—	μs
t_{SR}	Stable Supply Voltage to Reset High	10	—	ms
t_{CS}	Configuration Setup Time	5	—	ns
t_{CH}	Configuration Hold Time	5	—	ns
t_{RC}	Reset to Strap-In Pin Output	6	—	ns

The supply voltage ($V_{DDIO_3.3}$ and $V_{DDA_3.3}$) power-up waveform should be monotonic. The 250 μs minimum rise time is from 10% to 90%.

After the de-assertion of reset, it is recommended to wait a minimum of 100 μs before starting programming on the MIIM (MDC/MDIO) Interface.

KSZ8041NL/RNL

7.10 Reset Circuit

The reset circuit in [Figure 7-11](#) is recommended for powering up the KSZ8041NL/RNL if reset is triggered by the power supply.

FIGURE 7-11: RECOMMENDED RESET CIRCUIT

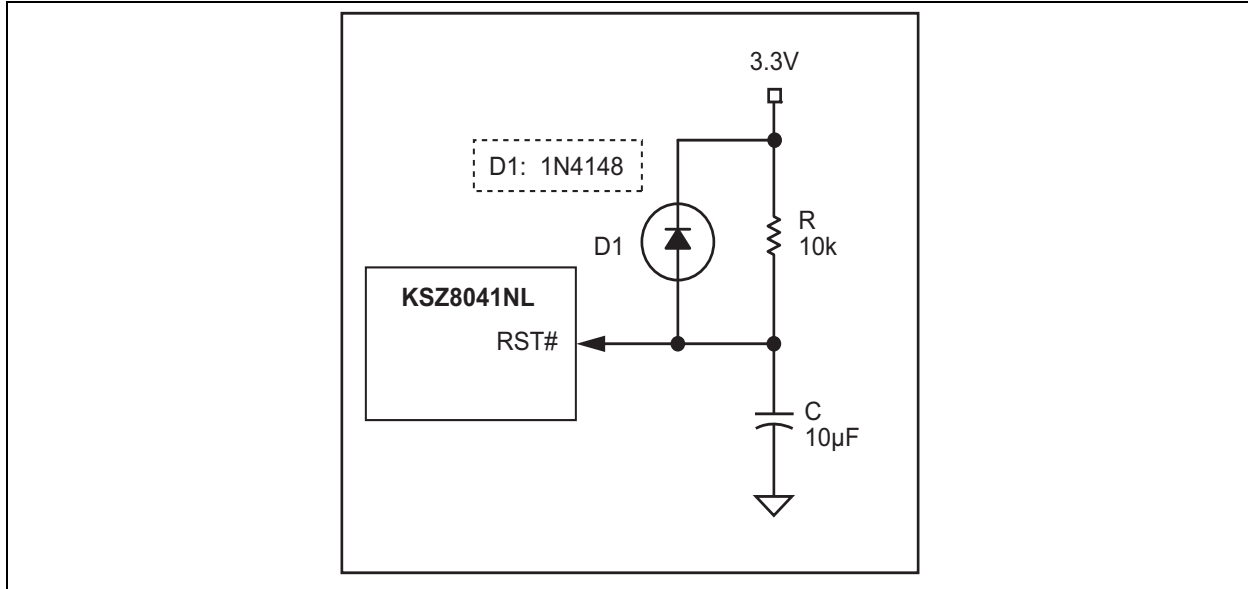

[Figure 7-12](#) shows a reset circuit recommended for applications where reset is driven by another device (for example, the CPU or an FPGA). The reset out RST_OUT_n from CPU/FPGA provides the warm reset after power up reset. D2 is required if using different V_{DDIO} voltage between switch and CPU/FPGA. Diode D2 should be selected to provide maximum 0.3V V_F (Forward Voltage), for example, VISHAY BAT54, MSS1P2L. Alternatively, a level shifter device can also be used. D2 is not required if PHY and CPU/FPGA use same V_{DDIO} voltage.

FIGURE 7-12: RECOMMENDED RESET CIRCUIT FOR INTERFACING WITH CPU/FPGA RESET OUTPUT

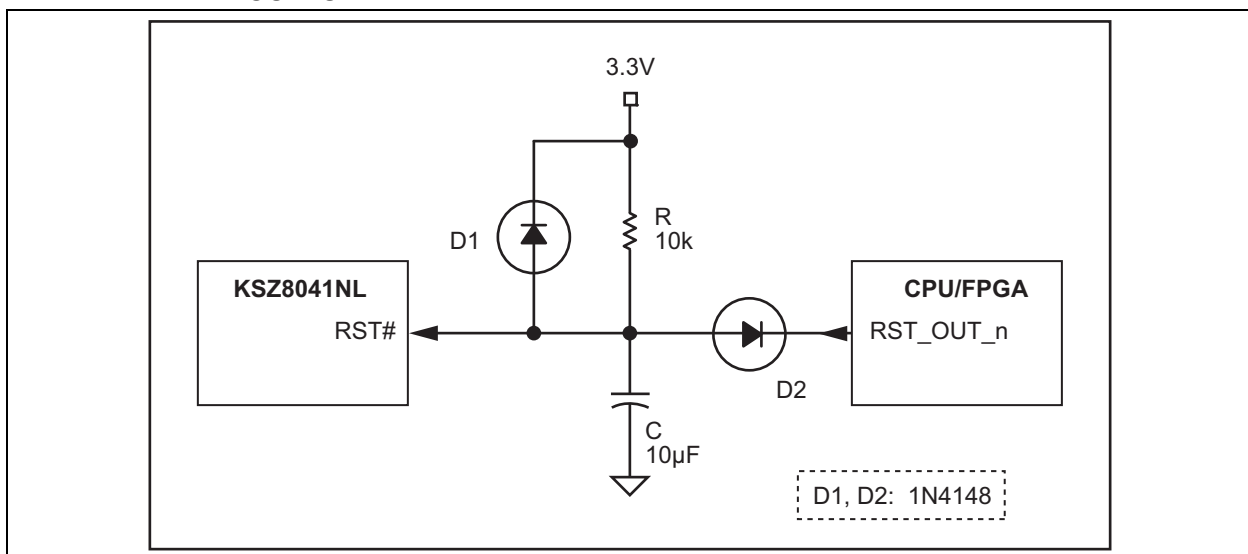

7.11 Reference Circuits for LED Strapping Pins

The [Figure 7-13](#) shows the reference circuits for pull-up, float and pull-down on the LED1 and LED0 strapping pins.

FIGURE 7-13: REFERENCE CIRCUITS FOR LED STRAPPING PINS

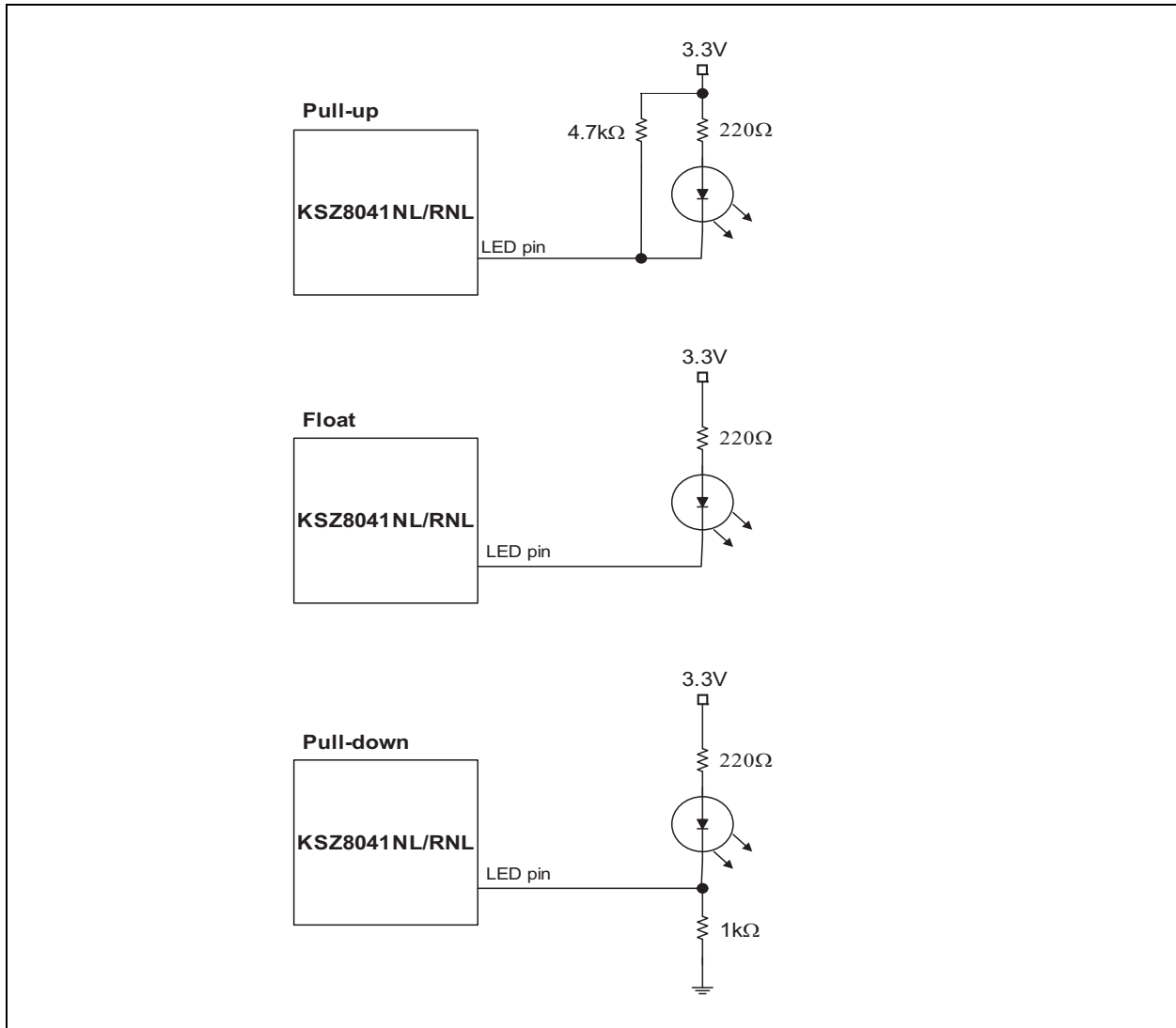

KSZ8041NL/RNL

8.0 SELECTION OF ISOLATION TRANSFORMER

A 1:1 isolation transformer is required at the line interface. An isolation transformer with integrated common-mode chokes is recommended for exceeding FCC requirements.

Table 8-1 gives recommended transformer characteristics.

TABLE 8-1: TRANSFORMER SELECTION CRITERIA

Parameter	Value	Test Condition
Turns Ratio	1 CT : 1 CT	—
Open-Circuit Inductance (minimum)	350 μ H	100 mV, 100 kHz, 8 mA
Leakage Inductance (maximum)	0.4 μ H	1 MHz (minimum)
Inter-Winding Capacitance (typical)	12 pF	—
DC Resistance (typical)	0.9 Ω	—
Insertion Loss (maximum)	-1.0 dB	0 MHz – 65 MHz
HIPOT (minimum)	1500 V _{RMS}	—

TABLE 8-2: QUALIFIED SINGLE PORT MAGNETICS

Magnetic Manufacturer	Part Number	Auto MDI-X	Number of Ports
Bel Fuse	S558-5999-U7	Yes	1
Bel Fuse (Mag Jack)	SI-46001	Yes	1
Bel Fuse (Mag Jack)	SI-50170	Yes	1
Delta	LF8505	Yes	1
LanKom	LF-H41S	Yes	1
Pulse	H1102	Yes	1
Pulse (low cost)	H1260	Yes	1
Transpower	HB726	Yes	1
TDK (Mag Jack)	TLA-6T718	Yes	1

9.0 SELECTION OF REFERENCE CRYSTAL

TABLE 9-1: TYPICAL REFERENCE CRYSTAL CHARACTERISTICS

Characteristics	Value	Units
Frequency	25	MHz
Frequency Tolerance (maximum)	±50	ppm
Load Capacitance	20	pF
Series Resistance	40	Ω

KSZ8041NL/RNL

10.0 PACKAGE OUTLINE & RECOMMENDED LAND PATTERN

FIGURE 10-1: 32-LEAD QFN 5X5 PACKAGE

TITLE

32 LEAD QFN 5x5mm PACKAGE OUTLINE & RECOMMENDED LAND PATTERN

DRAWING #	QFN55-32LD-PL-2	UNIT	MM
-----------	-----------------	------	----

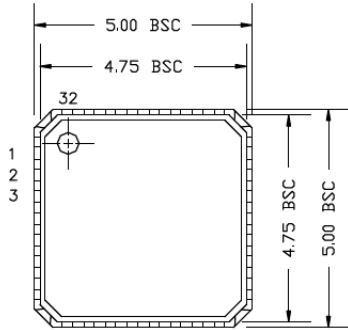

TOP VIEW

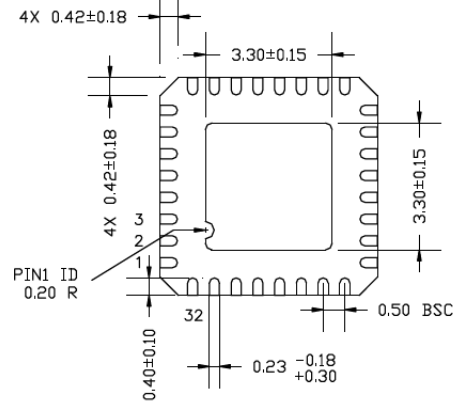

BOTTOM VIEW

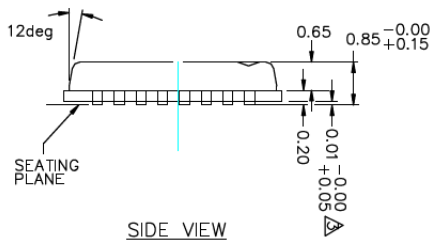

SIDE VIEW

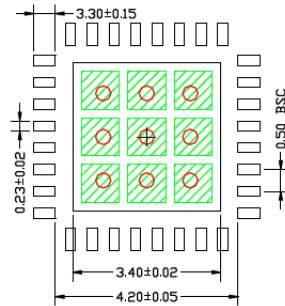

RECOMMENDED LAND PATTERN
NOTE 4, 5

- NOTES:
1. THE PIN1 IDENTIFIER MUST EXIST ON THE TOP SURFACE OF PACKAGE USING IDENTIFICATION MARK OR OTHER FEATURE OF PACKAGE BODY.
 2. PACKAGE WRAPAGE MAX 0.05MM.
 3. APPLIES TO EXPOSED PAD AND TERMINALS.
 4. RED CIRCLE IN LAND PATTERN INDICATE THERMAL VIA. SIZE SHOULD BE 0.30-0.3M IN DIAMETER AND SHOULD BE CONNECTED TO GND FOR MAX THERMAL PERFORMANCE
 5. GREEN RECTANGLES (SHADED AREA) INDICATE SOLDER STENCIL OPENING ON EXPOSED PAD AREA. SIZE SHOULD BE 0.87x0.87 MM IN SIZE, 1.07 MM PITCH.

Note: For the most current package drawings, please see the Microchip Packaging Specification located at <http://www.microchip.com/packaging>.

APPENDIX A: DATA SHEET REVISION HISTORY

TABLE A-1: REVISION HISTORY

Revision	Section/Figure/E0try	Correction
DS00002245A (05-02-17)	ALL	KSZ8041NL/RNL Datasheet initial conversion to Microchip DS00002245A.

THE MICROCHIP WEB SITE

Microchip provides online support via our WWW site at www.microchip.com. This web site is used as a means to make files and information easily available to customers. Accessible by using your favorite Internet browser, the web site contains the following information:

- **Product Support** – Data sheets and errata, application notes and sample programs, design resources, user's guides and hardware support documents, latest software releases and archived software
- **General Technical Support** – Frequently Asked Questions (FAQ), technical support requests, online discussion groups, Microchip consultant program member listing
- **Business of Microchip** – Product selector and ordering guides, latest Microchip press releases, listing of seminars and events, listings of Microchip sales offices, distributors and factory representatives

CUSTOMER CHANGE NOTIFICATION SERVICE

Microchip's customer notification service helps keep customers current on Microchip products. Subscribers will receive e-mail notification whenever there are changes, updates, revisions or errata related to a specified product family or development tool of interest.

To register, access the Microchip web site at www.microchip.com. Under "Support", click on "Customer Change Notification" and follow the registration instructions.

CUSTOMER SUPPORT

Users of Microchip products can receive assistance through several channels:

- Distributor or Representative
- Local Sales Office
- Field Application Engineer (FAE)
- Technical Support

Customers should contact their distributor, representative or field application engineer (FAE) for support. Local sales offices are also available to help customers. A listing of sales offices and locations is included in the back of this document.

Technical support is available through the web site at: <http://microchip.com/support>

PRODUCT IDENTIFICATION SYSTEM

To order or obtain information, e.g., on pricing or delivery, refer to the factory or the listed sales office.

<u>PART NO.</u>	X	X	X	X
Device	Interface	Package	Power	Temperature Option
Device: Interface: Package: Power Option: Temperature:	KSZ8041 – 10BASE-T/100BASE-TX Physical Layer Transceiver Blank = MII/RMII R = RMII	N = 32-pin QFN	L = Integrated LDO/LDO Controller/Regulator	Blank = Commercial (0°C to +70°C) I = Industrial (–40°C to +85°C) U = Automotive Grade 3 (–40°C to +85°C) (RMII Versions Only) AM = Automotive Grade 3 (–40°C to +85°C) (MII/RMII Version Only)

Examples:

- a) KSZ8041NL – 10BASE-T/100BASE-TX Physical Layer Transceiver, MII/RMII, 32-pin QFN Commercial temperature
- b) KSZ8041NLI – 10BASE-T/100BASE-TX Physical Layer Transceiver, MII/RMII, 32-pin QFN, Industrial Temperature
- c) KSZ8041NL-AM – 10BASE-T/100BASE-TX Physical Layer Transceiver, MII/RMII, 32-pin QFN Industrial temperature, Automotive Grade 3
- d) KSZ8041RNLU – 10BASE-T/100BASE-TX Physical Layer Transceiver, RMII, 32-pin QFN Automotive Grade 3
- e) KSZ8041RNL – 10BASE-T/100BASE-TX Physical Layer Transceiver, RMII, 32-pin QFN, Commercial temperature
- f) KSZ8041RNLI – 10BASE-T/100BASE-TX Physical Layer Transceiver, RMII, 32-pin QFN, Industrial temperature

KSZ8041NL/RNL

Note the following details of the code protection feature on Microchip devices:

- Microchip products meet the specification contained in their particular Microchip Data Sheet.
- Microchip believes that its family of products is one of the most secure families of its kind on the market today, when used in the intended manner and under normal conditions.
- There are dishonest and possibly illegal methods used to breach the code protection feature. All of these methods, to our knowledge, require using the Microchip products in a manner outside the operating specifications contained in Microchip's Data Sheets. Most likely, the person doing so is engaged in theft of intellectual property.
- Microchip is willing to work with the customer who is concerned about the integrity of their code.
- Neither Microchip nor any other semiconductor manufacturer can guarantee the security of their code. Code protection does not mean that we are guaranteeing the product as “unbreakable.”

Code protection is constantly evolving. We at Microchip are committed to continuously improving the code protection features of our products. Attempts to break Microchip's code protection feature may be a violation of the Digital Millennium Copyright Act. If such acts allow unauthorized access to your software or other copyrighted work, you may have a right to sue for relief under that Act.

Information contained in this publication regarding device applications and the like is provided only for your convenience and may be superseded by updates. It is your responsibility to ensure that your application meets with your specifications. MICROCHIP MAKES NO REPRESENTATIONS OR WARRANTIES OF ANY KIND WHETHER EXPRESS OR IMPLIED, WRITTEN OR ORAL, STATUTORY OR OTHERWISE, RELATED TO THE INFORMATION, INCLUDING BUT NOT LIMITED TO ITS CONDITION, QUALITY, PERFORMANCE, MERCHANTABILITY OR FITNESS FOR PURPOSE. Microchip disclaims all liability arising from this information and its use. Use of Microchip devices in life support and/or safety applications is entirely at the buyer's risk, and the buyer agrees to defend, indemnify and hold harmless Microchip from any and all damages, claims, suits, or expenses resulting from such use. No licenses are conveyed, implicitly or otherwise, under any Microchip intellectual property rights unless otherwise stated.

Trademarks

The Microchip name and logo, the Microchip logo, AnyRate, AVR, AVR logo, AVR Freaks, BeaconThings, BitCloud, CryptoMemory, CryptoRF, dsPIC, FlashFlex, flexPWR, Helder, JukeBlox, KEELOQ, KEELOQ logo, Kieer, LANCheck, LINK MD, maXStylus, maXTouch, MediaLB, megaAVR, MOST, MOST logo, MPLAB, OptoLyzer, PIC, picoPower, PICSTART, PIC32 logo, Prochip Designer, QTouch, RightTouch, SAM-BA, SpyNIC, SST, SST Logo, SuperFlash, tinyAVR, UNI/O, and XMEGA are registered trademarks of Microchip Technology Incorporated in the U.S.A. and other countries.

ClockWorks, The Embedded Control Solutions Company, EtherSynch, Hyper Speed Control, HyperLight Load, IntelliMOS, mTouch, Precision Edge, and Quiet-Wire are registered trademarks of Microchip Technology Incorporated in the U.S.A.

Adjacent Key Suppression, AKS, Analog-for-the-Digital Age, Any Capacitor, AnyIn, AnyOut, BodyCom, chipKIT, chipKIT logo, CodeGuard, CryptoAuthentication, CryptoCompanion, CryptoController, dsPICDEM, dsPICDEM.net, Dynamic Average Matching, DAM, ECAN, EtherGREEN, In-Circuit Serial Programming, ICSP, Inter-Chip Connectivity, JitterBlocker, KleerNet, KleerNet logo, Mindi, MiWi, motorBench, MPASM, MPF, MPLAB Certified logo, MPLIB, MPLINK, MultiTRAK, NetDetach, Omniscient Code Generation, PICDEM, PICDEM.net, PICkit, PICtail, PureSilicon, QMatrix, RightTouch logo, REAL ICE, Ripple Blocker, SAM-ICE, Serial Quad I/O, SMART-I.S., SQI, SuperSwitcher, SuperSwitcher II, Total Endurance, TSHARC, USBCheck, VariSense, ViewSpan, WiperLock, Wireless DNA, and ZENA are trademarks of Microchip Technology Incorporated in the U.S.A. and other countries.

SQTP is a service mark of Microchip Technology Incorporated in the U.S.A.

Silicon Storage Technology is a registered trademark of Microchip Technology Inc. in other countries.

GestIC is a registered trademark of Microchip Technology Germany II GmbH & Co. KG, a subsidiary of Microchip Technology Inc., in other countries.

All other trademarks mentioned herein are property of their respective companies.

© 2016, Microchip Technology Incorporated, All Rights Reserved.

ISBN: 978-1-5224-1691-3

QUALITY MANAGEMENT SYSTEM
CERTIFIED BY DNV
== ISO/TS 16949 ==

Microchip received ISO/TS-16949:2009 certification for its worldwide headquarters, design and wafer fabrication facilities in Chandler and Tempe, Arizona; Gresham, Oregon and design centers in California and India. The Company's quality system processes and procedures are for its PIC® MCUs and dsPIC® DSCs, KEELOQ® code hopping devices, Serial EEPROMs, microperipherals, nonvolatile memory and analog products. In addition, Microchip's quality system for the design and manufacture of development systems is ISO 9001:2000 certified.



MICROCHIP

Worldwide Sales and Service

AMERICAS

Corporate Office
2355 West Chandler Blvd.
Chandler, AZ 85224-6199
Tel: 480-792-7200
Fax: 480-792-7277
Technical Support:
<http://www.microchip.com/support>
Web Address:
www.microchip.com

Atlanta
Duluth, GA
Tel: 678-957-9614
Fax: 678-957-1455

Austin, TX
Tel: 512-257-3370

Boston
Westborough, MA
Tel: 774-760-0087
Fax: 774-760-0088

Chicago
Itasca, IL
Tel: 630-285-0071
Fax: 630-285-0075

Dallas
Addison, TX
Tel: 972-818-7423
Fax: 972-818-2924

Detroit
Novi, MI
Tel: 248-848-4000

Houston, TX
Tel: 281-894-5983

Indianapolis
Noblesville, IN
Tel: 317-773-8323
Fax: 317-773-5453
Tel: 317-536-2380

Los Angeles
Mission Viejo, CA
Tel: 949-462-9523
Fax: 949-462-9608
Tel: 951-273-7800

Raleigh, NC
Tel: 919-844-7510

New York, NY
Tel: 631-435-6000

San Jose, CA
Tel: 408-735-9110
Tel: 408-436-4270

Canada - Toronto
Tel: 905-695-1980
Fax: 905-695-2078

ASIA/PACIFIC

Asia Pacific Office
Suites 3707-14, 37th Floor
Tower 6, The Gateway
Harbour City, Kowloon

Hong Kong
Tel: 852-2943-5100
Fax: 852-2401-3431

Australia - Sydney
Tel: 61-2-9868-6733
Fax: 61-2-9868-6755

China - Beijing
Tel: 86-10-8569-7000
Fax: 86-10-8528-2104

China - Chengdu
Tel: 86-28-8665-5511
Fax: 86-28-8665-7889

China - Chongqing
Tel: 86-23-8980-9588
Fax: 86-23-8980-9500

China - Dongguan
Tel: 86-769-8702-9880

China - Guangzhou
Tel: 86-20-8755-8029

China - Hangzhou
Tel: 86-571-8792-8115
Fax: 86-571-8792-8116

China - Hong Kong SAR
Tel: 852-2943-5100
Fax: 852-2401-3431

China - Nanjing
Tel: 86-25-8473-2460
Fax: 86-25-8473-2470

China - Qingdao
Tel: 86-532-8502-7355
Fax: 86-532-8502-7205

China - Shanghai
Tel: 86-21-3326-8000
Fax: 86-21-3326-8021

China - Shenyang
Tel: 86-24-2334-2829
Fax: 86-24-2334-2393

China - Shenzhen
Tel: 86-755-8864-2200
Fax: 86-755-8203-1760

China - Wuhan
Tel: 86-27-5980-5300
Fax: 86-27-5980-5118

China - Xian
Tel: 86-29-8833-7252
Fax: 86-29-8833-7256

ASIA/PACIFIC

China - Xiamen
Tel: 86-592-2388138
Fax: 86-592-2388130

China - Zhuhai
Tel: 86-756-3210040
Fax: 86-756-3210049

India - Bangalore
Tel: 91-80-3090-4444
Fax: 91-80-3090-4123

India - New Delhi
Tel: 91-11-4160-8631
Fax: 91-11-4160-8632

India - Pune
Tel: 91-20-3019-1500

Japan - Osaka
Tel: 81-6-6152-7160
Fax: 81-6-6152-9310

Japan - Tokyo
Tel: 81-3-6880-3770
Fax: 81-3-6880-3771

Korea - Daegu
Tel: 82-53-744-4301
Fax: 82-53-744-4302

Korea - Seoul
Tel: 82-2-554-7200
Fax: 82-2-558-5932 or
82-2-558-5934

Malaysia - Kuala Lumpur
Tel: 60-3-6201-9857
Fax: 60-3-6201-9859

Malaysia - Penang
Tel: 60-4-227-8870
Fax: 60-4-227-4068

Philippines - Manila
Tel: 63-2-634-9065
Fax: 63-2-634-9069

Singapore
Tel: 65-6334-8870
Fax: 65-6334-8850

Taiwan - Hsin Chu
Tel: 886-3-5778-366
Fax: 886-3-5770-955

Taiwan - Kaohsiung
Tel: 886-7-213-7830

Taiwan - Taipei
Tel: 886-2-2508-8600
Fax: 886-2-2508-0102

Thailand - Bangkok
Tel: 66-2-694-1351
Fax: 66-2-694-1350

EUROPE

Austria - Wels
Tel: 43-7242-2244-39
Fax: 43-7242-2244-393

Denmark - Copenhagen
Tel: 45-4450-2828
Fax: 45-4485-2829

Finland - Espoo
Tel: 358-9-4520-820

France - Paris
Tel: 33-1-69-53-63-20
Fax: 33-1-69-30-90-79

France - Saint Cloud
Tel: 33-1-30-60-70-00

Germany - Garching
Tel: 49-8931-9700

Germany - Haan
Tel: 49-2129-3766400

Germany - Heilbronn
Tel: 49-7131-67-3636

Germany - Karlsruhe
Tel: 49-721-625370

Germany - Munich
Tel: 49-89-627-144-0
Fax: 49-89-627-144-44

Germany - Rosenheim
Tel: 49-8031-354-560

Israel - Ra'anana
Tel: 972-9-744-7705

Italy - Milan
Tel: 39-0331-742611
Fax: 39-0331-466781

Italy - Padova
Tel: 39-049-7625286

Netherlands - Drunen
Tel: 31-416-690399
Fax: 31-416-690340

Norway - Trondheim
Tel: 47-7289-7561

Poland - Warsaw
Tel: 48-22-3325737

Romania - Bucharest
Tel: 40-21-407-87-50

Spain - Madrid
Tel: 34-91-708-08-90
Fax: 34-91-708-08-91

Sweden - Gothenberg
Tel: 46-31-704-60-40

Sweden - Stockholm
Tel: 46-8-5090-4654

UK - Wokingham
Tel: 44-118-921-5800
Fax: 44-118-921-5820