

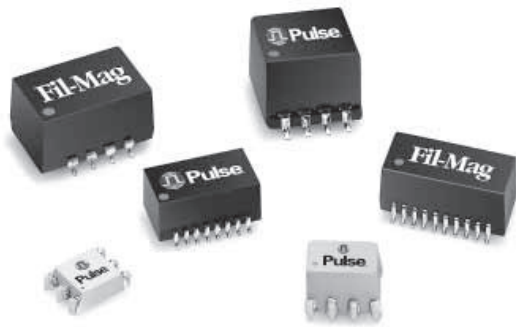



SURFACE MOUNT COMMON MODE CHOKES

Suited for LAN and Telecom Applications



-  Reduces radiated EMI emissions
-  Filters common mode noise for EMI reduction
-  Common mode attenuation from 100 kHz to 1 GHz
-  Tape & Reel packaging available for surface mount parts*

Electrical Specifications @ 25°C

| Part Number | No. of Ports | Primary Inductance OCL (μH MIN) | Common Mode Attenuation (db TYP) | | | | | | | | | DCR (Ω MAX) | Page Number Mech & Schem |
|-------------|--------------|---------------------------------|----------------------------------|-------|-------|-------|-------|--------|--------|--------|-------|-------------|--------------------------|
| | | | 100KHz | 1 MHz | 10MHz | 30MHz | 50MHz | 100MHz | 300MHz | 500MHz | 1 GHz | | |
| PE-68624 | 2 | 47 | 11 | 27 | 40 | 44 | 42 | 36 | 26 | 17 | — | 0.40 | 2 |
| PE-65855 | 2 | 4700 | 41 | 43 | 49 | 39 | 34 | 26 | 20 | 20 | 12 | 1.0 | 4 |
| B2013 | 2 | 6300 | 46 | 47 | 43 | 32 | 25 | 29 | 21 | 14 | 16 | 1.0 | 3 |
| B4003 | 2 | 4700 | 42 | 41 | 48 | 38 | 33 | 21 | 22 | 23 | 17 | 1.0 | 6 |
| 23Z87SM | 3 | 69 | 9 | 24 | 31 | 30 | 29 | 27 | 21 | 16 | — | 0.20 | 4 |
| PE-65857 | 4 | 22.5 | 7 | 20 | 30 | 37 | 38 | 34 | 24 | 13 | — | 0.22 | 4 |
| PE-68627 | 4 | 24 | 8 | 21 | 32 | 36 | 37 | 36 | 30 | 20 | — | 0.25 | 4 |
| T8003 | 4 | 33 | 9 | 13 | 32 | 32 | 30 | 27 | 16 | 17 | 13 | 0.20 | 6 |
| 23Z400SM | 4 | 36 | 7 | 23 | 35 | 38 | 38 | 36 | 29 | 24 | — | 0.50 | 5 |
| PE-65854 | 4 | 47 | 3 | 19 | 32 | 36 | 35 | 29 | 12 | 6 | — | 0.40 | 3 |
| 23Z104SM | 4 | 68 | 8 | 22 | 28 | 28 | 27 | 25 | 20 | 15 | — | 0.20 | 5 |
| PE-67540 | 4 | 100 | 14 | 33 | 44 | 48 | 49 | 44 | 34 | 29 | 20 | 0.60 | 4 |
| PE-65853 | 4 | 4700 | 40 | 51 | 38 | 30 | 25 | 20 | 14 | 13 | — | 1.20 | 3 |
| 23Z106SM | 6 | 68 | 8 | 22 | 29 | 30 | 30 | 29 | 24 | 19 | — | 0.20 | 5 |
| PE-68011 | 8 | 36 | 8 | 24 | 36 | 39 | 35 | 29 | 18 | 11 | — | 0.35 | 3 |
| 23Z105SM | 8 | 68 | 8 | 24 | 30 | 29 | 27 | 24 | 16 | 11 | — | 0.20 | 5 |
| 23Z109SM | 10 | 7.5 | 4 | 9 | 20 | 25 | 26 | 24 | 16 | 11 | — | 0.20 | 5 |
| T8008 | 16 | 47 | 7 | 27 | 40 | 44 | 42 | 36 | 26 | — | — | 0.40 | 6 |

* When ordering Tape & Reel packaging, add a "T" at the end of the part number (i.e. PE-65738T or 23Z106SM T).

NOTE: Additional common mode chokes are available. Please contact Applications Engineering.

Mechanical

Schematic

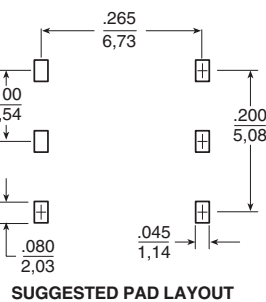
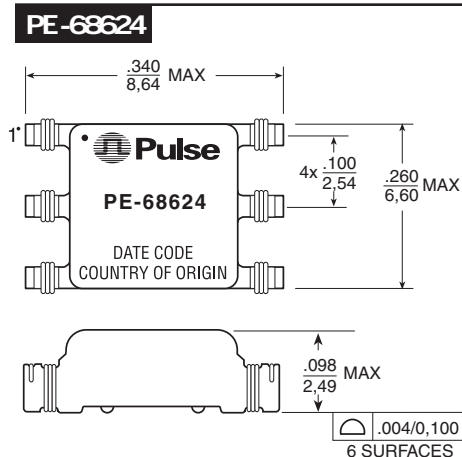

Weight 0.17 grams
Tape & Reel 1500/reel
Tube 85/tube

SURFACE MOUNT COMMON MODE CHOKES

Suited for LAN and Telecom Applications



Mechanical

Schematic

PE-69011

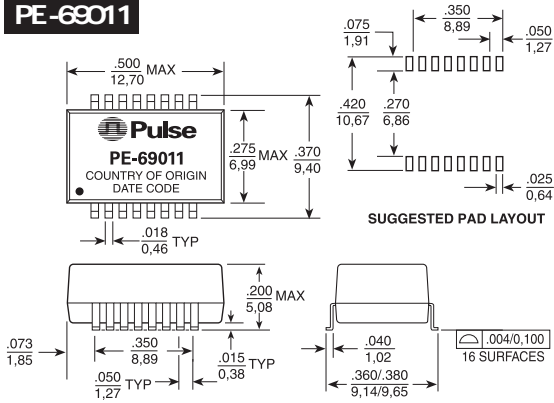

Dimensions: $\frac{\text{Inches}}{\text{mm}}$

Unless otherwise specified,
all tolerances are $\pm .010$
 $0,25$

Weight 0.83 grams

Tape & Reel 900/reel

Tube 40/tube

PE-69011

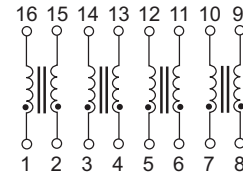

PE-65853

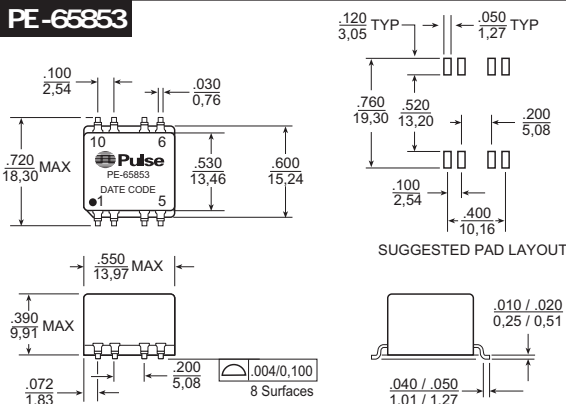

Dimensions: $\frac{\text{Inches}}{\text{mm}}$

Unless otherwise specified,
all tolerances are $\pm .010$
 $0,25$

Weight 4.0 grams

Tape & Reel 150/reel

Tube 35/tube

PE-65853

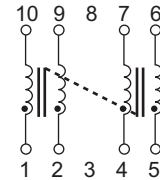

B2013

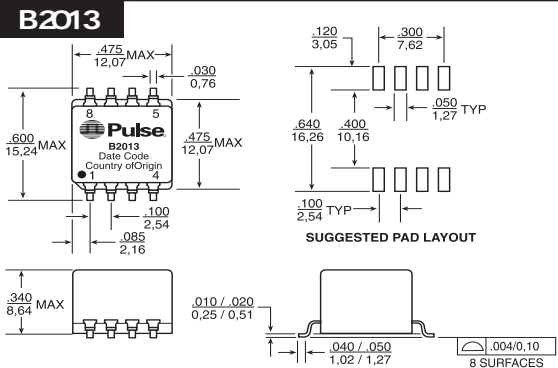

Dimensions: $\frac{\text{Inches}}{\text{mm}}$

Unless otherwise specified,
all tolerances are $\pm .010$
 $0,25$

Weight 9.5 grams

Tray 30/tray

B2013



PE-65854

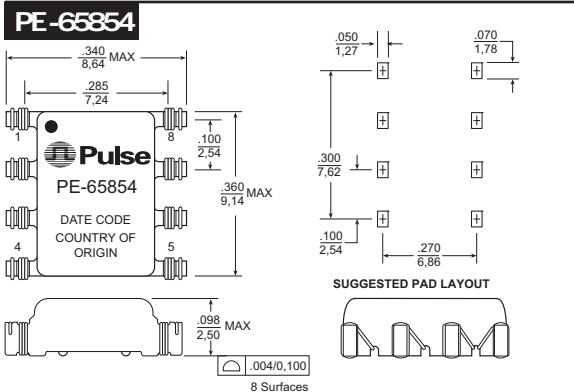

Dimensions: $\frac{\text{Inches}}{\text{mm}}$

Unless otherwise specified,
all tolerances are $\pm .010$
 $0,25$

Weight 0.3 grams

Tape & Reel 1500/reel

Tube 60/tube

PE-65854

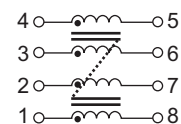

SURFACE MOUNT COMMON MODE CHOKES

Suited for LAN and Telecom Applications



Mechanical

Schematic

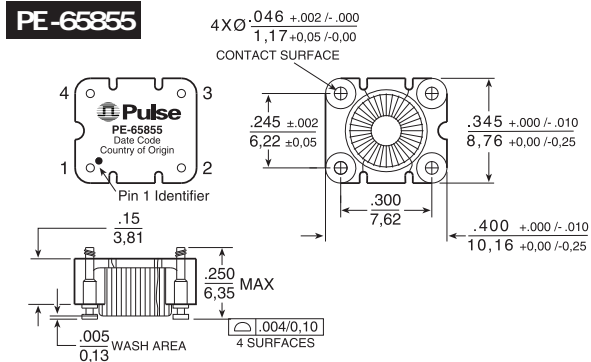

Dimensions: Inches
mm

Unless otherwise specified,
all tolerances are $\pm .010$
0,25

Weight 0.69 grams
Tape & Reel 800/reel
Tube 40/tube

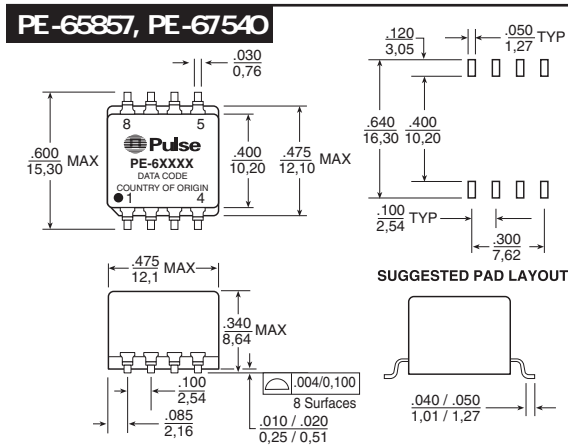
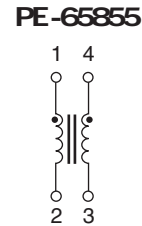

Dimensions: Inches
mm

Unless otherwise specified,
all tolerances are $\pm .010$
0,25

Weight 2.0 grams
Tape & Reel 250/reel
Tube 40/tube

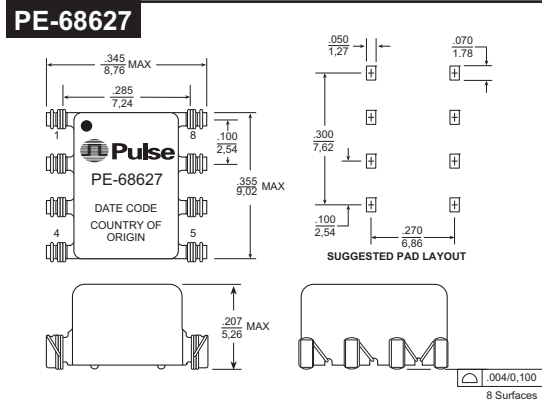
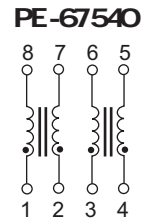
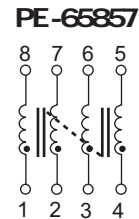

Dimensions: Inches
mm

Unless otherwise specified,
all tolerances are $\pm .010$
0,25

Weight 0.3 grams
Tape & Reel 1500/reel
Tube 55/tube

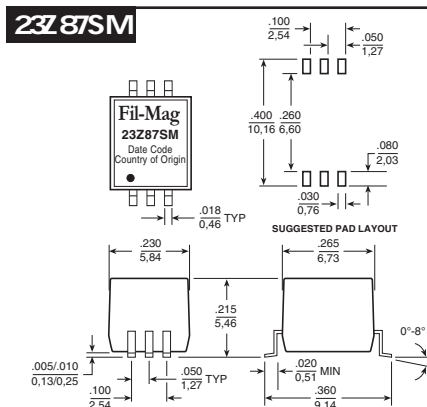
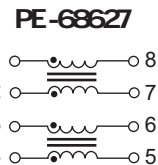

Dimensions: Inches
mm

Unless otherwise specified,
all tolerances are $\pm .005$
0,13

Weight 0.5 grams
Tape & Reel 750/reel
Tube 100/tube

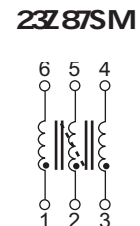

SURFACE MOUNT COMMON MODE CHOKES

Suited for LAN and Telecom Applications



Mechanical

Schematic

23Z104SM

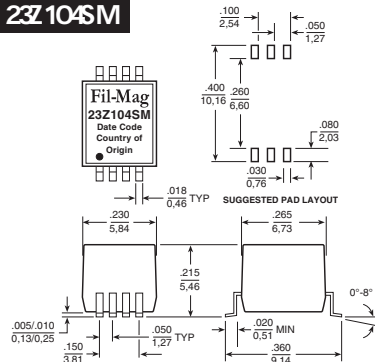

Dimensions: Inches
mm

Unless otherwise specified,
all tolerances are $\pm .005$
0,13

Weight 0.5 grams
Tape & Reel 750/reel
Tube 100/tube

23Z104SM

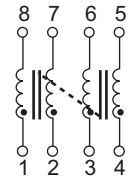

23Z105SM, 23Z106SM

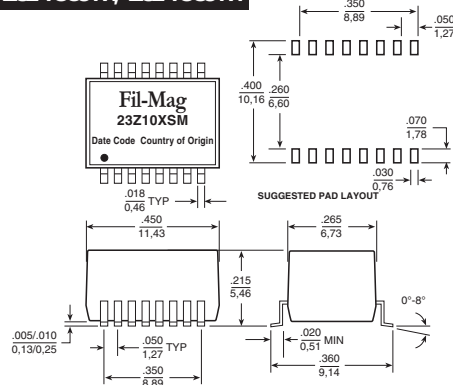

Dimensions: Inches
mm

Unless otherwise specified,
all tolerances are $\pm .005$
0,13

23Z105SM 23Z106SM
Weight 0.8 grams 1.0 grams
Tape & Reel 750/reel 750/reel
Tube 50/tube 50/tube

23Z105SM

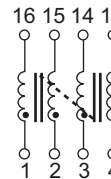

23Z106SM

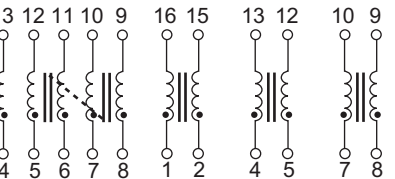

23Z109SM

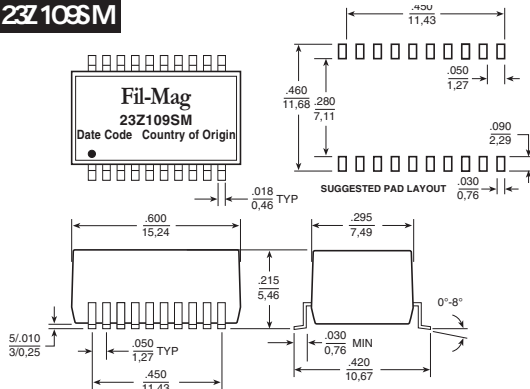

Dimensions: Inches
mm

Unless otherwise specified,
all tolerances are $\pm .005$
0,13

Weight 1.3 grams
Tape & Reel 500/reel
Tube 38/tube

23Z109SM

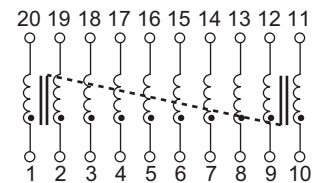

23Z4006MD

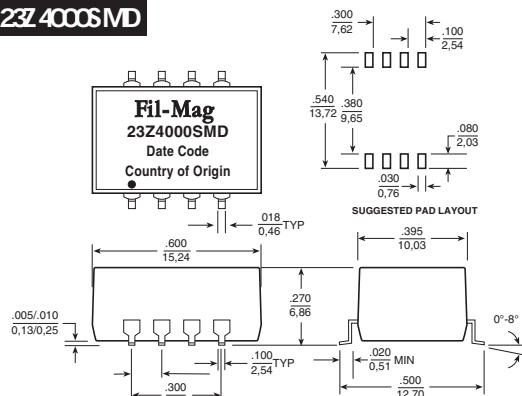

Dimensions: Inches
mm

Unless otherwise specified,
all tolerances are $\pm .005$
0,13

Weight 2.1 grams
Tape & Reel 350/reel
Tube 38/tube

23Z4006MD

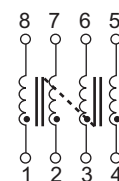

SURFACE MOUNT COMMON MODE CHOKES

Suited for LAN and Telecom Applications



Mechanical

Schematic

T8003

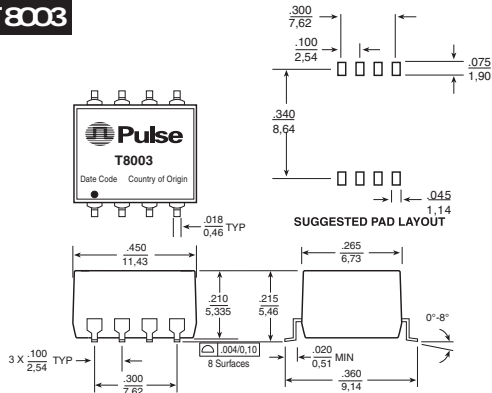

Dimensions: $\frac{\text{Inches}}{\text{mm}}$

Unless otherwise specified,
all tolerances are $\pm .005$ -
0,13

Weight 0.84 grams
Tape & Reel 750/reel
Tube 100/tube

T8003

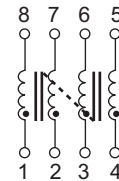

T8055

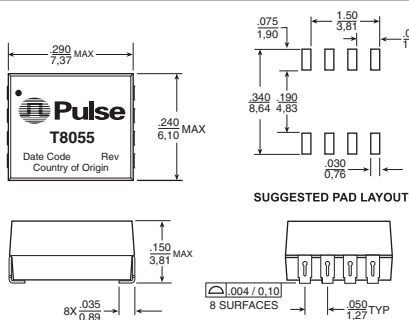

Dimensions: $\frac{\text{Inches}}{\text{mm}}$

Unless otherwise specified,
all tolerances are $\pm .010$ -
0,25

Weight 0.2 grams
Tape & Reel 1750/reel
Tube 80/tube

T8055

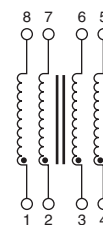

B4003

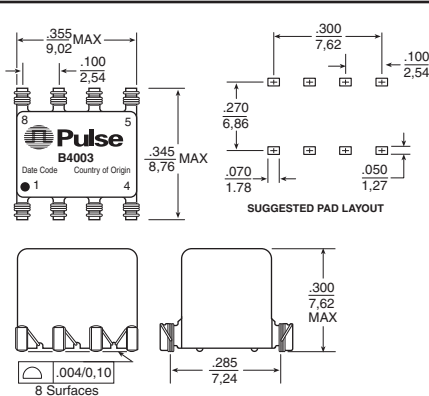

Dimensions: $\frac{\text{Inches}}{\text{mm}}$

Unless otherwise specified,
all tolerances are $\pm .010$ -
0,25

Weight 1.0 grams
Tape & Reel 425/reel
Tube 50/tube

B4003

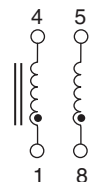

T8008

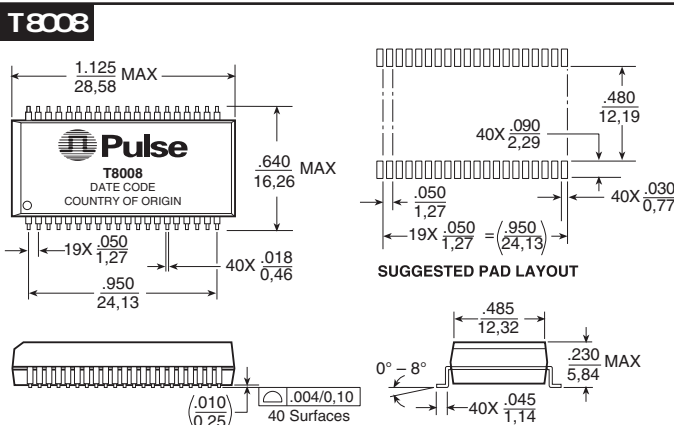

Dimensions: $\frac{\text{Inches}}{\text{mm}}$

Unless otherwise specified,
all tolerances are $\pm .010$ -
0,25

Weight 4.0 grams
Tape & Reel 250/reel
Tube 15/tube

T8008

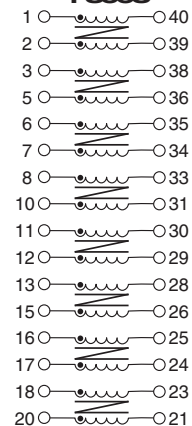

NOTE: The common mode test circuit for surface mount is the same as for through hole and is on the back page.