

Applications

- Usable Bandwidth of 69 MHz (CH1-11)
- High-power WLAN Access Points and Small Cells
- Band-edge filtering of WiFi signal emissions at 2390 MHz and 2483.5 MHz
- WiFi bandpass filter that enables the coexistence of 4G (LTE/TD-LTE) & WiFi signals
- ISM band applications such as Smart Meters
- Portable Hotspots and Mobile Routers

Product Features

- Industry leading small size: 1.70 x 1.30 x 0.46 mm
- Performance over -40 to +95° C
- High Rejection at 2390 MHz, 2483.5 MHz, B38/B40/B7/B41
- Ceramic chip-scale Package (CSP)
- Hermetically sealed
- RoHS compliant, Pb-free 

General Description

The 885070 is a high-performance, high power Bulk Acoustic Wave (BAW) band-pass filter with extremely steep skirts, simultaneously exhibiting low loss in the WiFi band and high rejection in the band-edge and adjacent LTE /TD-LTE bands.

The 885070 enables coexistence of WiFi and LTE signals within the same device or in close proximity to one another. Its unique power handling capability allows for implementation into high performance high power access points and small cell base stations.

The 885070 uses common module packaging techniques to achieve the industry standard 1.7 x 1.32 x 0.46 mm footprint. The filter exhibits industry leading power handling capabilities up to 1 W.

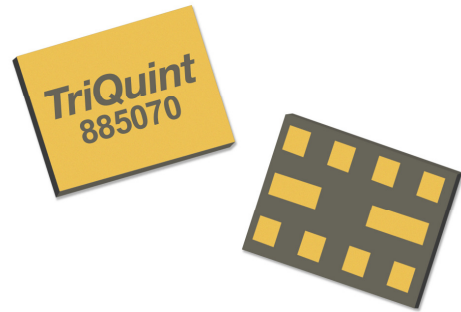

CSP-1713 package: 1.70 x 1.30 x 0.46 mm

Functional Block Diagram

Top View

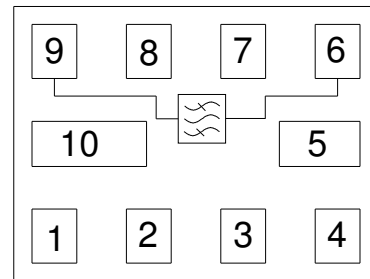

Pin Configuration

Pin No.	Label
9	Input
6	Output
1,2,3,4,5,7,8,10	Case Ground

Ordering Information

Part No.	Description
885070	Packaged part
885070-EVB	Evaluation board

Standard T/R size = 15,000 units/reef

Absolute Maximum Ratings

Parameter	Rating
Storage Temperature ⁽¹⁾	-55 to +125°C
Operable Temperature	-40 to +95°C

1. Operation of this device outside the parameter ranges given may cause permanent damage.
2. Input power with WLAN OFDM signal applied.

MTTF

Input Power ⁽²⁾	+70 °C	+85 °C	+95 °C
+24 dBm	> 1 B Hours	> 1 B Hours	> 1 B Hours
+26 dBm	724 M hours	183 M hours	73 M Hours
+28 dBm	3.01 M Hours	0.76 M Hours	0.31 M Hours

Electrical Specifications ⁽¹⁾

Conditions unless otherwise noted: Device Temperature = -40°C to +95°C.

Parameter ⁽²⁾	Conditions	Min	Typ ⁽³⁾	Max	Units
Insertion Loss ⁽⁴⁾	2402.5 – 2421.5 MHz (WiFi Ch.1)		1.2	1.7	dB
	2407.5 – 2426.5 MHz (WiFi Ch.2)		1.0	1.2	
	2412.5 – 2461.5 MHz (WiFi Ch.3-9)	-	0.8	1.1	
	2447.5 – 2466.5 MHz (WiFi Ch.10)		0.9	1.2	
	2452.5 – 2471.5 MHz (WiFi Ch.11)		1.0	1.7	
Amplitude Variation	2402.5 – 2421.5 MHz (WiFi Ch.1)		1.5	3.0	dB
	2407.5 – 2426.5 MHz (WiFi Ch.2)		0.8	1.2	
	2412.5 – 2461.5 MHz (WiFi Ch.3-9)	-	0.5	1.0	
	2447.5 – 2466.5 MHz (WiFi Ch.10)		0.5	1.2	
	2452.5 – 2471.5 MHz (WiFi Ch.11)		1.0	3.5	
Input/Output VSWR	2402.5 – 2471.5 MHz	-	1.5 ⁽⁶⁾	2.1 ⁽⁶⁾	-
Attenuation	100 – 2300 MHz	20	23	-	dB
	2300 – 2370 MHz ⁽⁵⁾	20	25	-	dB
	2370 – 2390 MHz ⁽⁵⁾	15	19	-	dB
	2483.5 – 2500 MHz ⁽⁵⁾	15	24	-	dB
	2500 – 2520 MHz ⁽⁵⁾	25	38	-	dB
	2520 – 2570 MHz ⁽⁵⁾	28	31	-	dB
	2570 – 2620 MHz ⁽⁵⁾	25	28	-	dB
	2620 – 2690 MHz ⁽⁵⁾	25	27	-	dB
4800 – 5000 MHz	25	29	-	dB	
Source/Load Impedance ⁽⁷⁾		-	50	-	Ω

Notes:

1. In production, devices will be tested at room temperature to a guard-banded specification to ensure electrical compliance over temperature.
2. Electrical margin has been built into the design to account for the variations due to temperature drift and manufacturing tolerances.
3. Only at 25°C.
4. Data is the integrated value of the linear s-parameter over a 19 MHz range in the indicated band at the specified temperature.
5. Data is the integrated value of the linear s-parameter over a 5 MHz range at the specified temperature.
6. An external impedance matching network with ±2 % tolerance will be necessary to achieve the stated specifications.
7. This is the optimum impedance in order to achieve the performance shown.

Electrical Specifications ⁽¹⁾

Conditions unless otherwise noted: Device Temperature = -30°C to +85°C.

Parameter ⁽²⁾	Conditions	Min	Typ ⁽³⁾	Max	Units
Insertion Loss ⁽⁴⁾	2402.5 – 2421.5 MHz (WiFi Ch.1)		1.2	1.6	dB
	2407.5 – 2426.5 MHz (WiFi Ch.2)		1.0	1.2	
	2412.5 – 2461.5 MHz (WiFi Ch.3-9)	-	0.8	1.1	
	2447.5 – 2466.5 MHz (WiFi Ch.10)		0.9	1.2	
	2452.5 – 2471.5 MHz (WiFi Ch.11)		1.0	1.6	
Amplitude Variation	2402.5 – 2421.5 MHz (WiFi Ch.1)		1.5	2.8	dB
	2407.5 – 2426.5 MHz (WiFi Ch.2)		0.8	1.2	
	2412.5 – 2461.5 MHz (WiFi Ch.3-9)	-	0.5	1.0	
	2447.5 – 2466.5 MHz (WiFi Ch.10)		0.5	1.2	
	2452.5 – 2471.5 MHz (WiFi Ch.11)		1.0	3.0	
Input/Output VSWR	2402.5 – 2471.5 MHz	-	1.5 ⁽⁶⁾	1.8 ⁽⁶⁾	-
Attenuation	100 – 2300 MHz	20	23	-	dB
	2300 – 2370 MHz ⁽⁵⁾	20	25	-	dB
	2370 – 2390 MHz ⁽⁵⁾	15	19	-	dB
	2483.5 – 2500 MHz ⁽⁵⁾	15	24	-	dB
	2500 – 2520 MHz ⁽⁵⁾	25	38	-	dB
	2520 – 2570 MHz ⁽⁵⁾	28	31	-	dB
	2570 – 2620 MHz ⁽⁵⁾	25	28	-	dB
	2620 – 2690 MHz ⁽⁵⁾	25	27	-	dB
4800 – 5000 MHz	25	29	-	dB	
Source/Load Impedance ⁽⁷⁾		-	50	-	Ω

Notes:

1. In production, devices will be tested at room temperature to a guard-banded specification to ensure electrical compliance over temperature.
2. Electrical margin has been built into the design to account for the variations due to temperature drift and manufacturing tolerances.
3. Only at 25°C.
4. Data is the integrated value of the linear s-parameter over a 19 MHz range in the indicated band at the specified temperature.
5. Data is the integrated value of the linear s-parameter over a 5 MHz range at the specified temperature.
6. An external impedance matching network with ±2 % tolerance will be necessary to achieve the stated specifications.
7. This is the optimum impedance in order to achieve the performance shown.

Electrical Specifications ⁽¹⁾

Conditions unless otherwise noted: Device Temperature = 0°C to +70°C.

Parameter ⁽²⁾	Conditions	Min	Typ ⁽³⁾	Max	Units
Insertion Loss ⁽⁴⁾	2402.5 – 2421.5 MHz (WiFi Ch.1)		1.2	1.5	dB
	2407.5 – 2426.5 MHz (WiFi Ch.2)		1.0	1.2	
	2412.5 – 2461.5 MHz (WiFi Ch.3-9)		0.8	1.1	
	2447.5 – 2466.5 MHz (WiFi Ch.10)		0.9	1.2	
	2452.5 – 2471.5 MHz (WiFi Ch.11)		1.0	1.5	
Amplitude Variation	2402.5 – 2421.5 MHz (WiFi Ch.1)		1.5	2.5	dB
	2407.5 – 2426.5 MHz (WiFi Ch.2)		0.8	1.1	
	2412.5 – 2461.5 MHz (WiFi Ch.3-9)		0.5	1.0	
	2447.5 – 2466.5 MHz (WiFi Ch.10)		0.5	1.1	
	2452.5 – 2471.5 MHz (WiFi Ch.11)		1.0	2.8	
Input/Output VSWR	2402.5 – 2471.5 MHz	-	1.5 ⁽⁶⁾	1.8 ⁽⁶⁾	-
Attenuation	100 – 2300 MHz	20	23	-	dB
	2300 – 2370 MHz ⁽⁵⁾	20	25	-	dB
	2370 – 2390 MHz ⁽⁵⁾	15	19	-	dB
	2483.5 – 2500 MHz ⁽⁵⁾	15	24	-	dB
	2500 – 2520 MHz ⁽⁵⁾	25	38	-	dB
	2520 – 2570 MHz ⁽⁵⁾	28	31	-	dB
	2570 – 2620 MHz ⁽⁵⁾	25	28	-	dB
	2620 – 2690 MHz ⁽⁵⁾	25	27	-	dB
4800 – 5000 MHz	25	29	-	dB	
Source/Load Impedance ⁽⁷⁾		-	50	-	Ω

Notes:

- In production, devices will be tested at room temperature to a guard-banded specification to ensure electrical compliance over temperature.
- Electrical margin has been built into the design to account for the variations due to temperature drift and manufacturing tolerances.
- Only at +25°C.
- Data is the integrated value of the linear s-parameter over a 19 MHz range in the indicated band at the specified temperature.
- Data is the integrated value of the linear s-parameter over a 5 MHz range at the specified temperature.
- An external impedance matching network with $\pm 2\%$ tolerance will be necessary to achieve the stated specifications.
- This is the optimum impedance in order to achieve the performance shown.

Evaluation Board

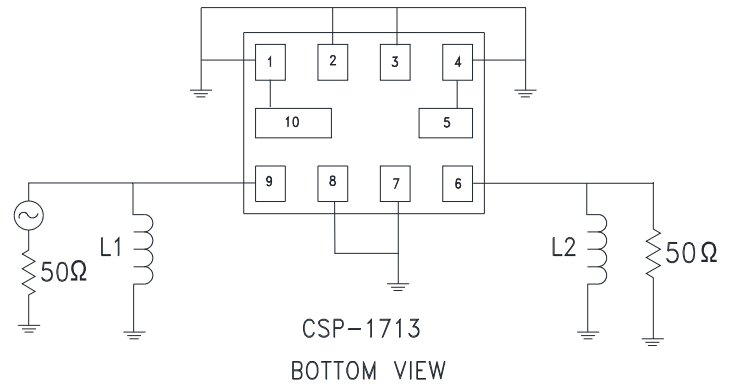
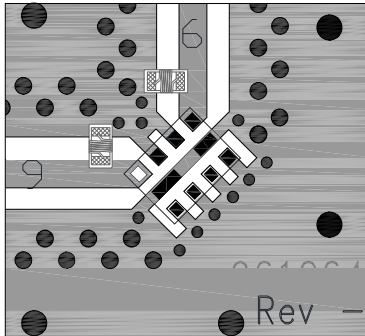

Notes:

1. Matching component values shown are for the specified TriQuint evaluation board. Value adjustment may be required in end user product circuits depending on component manufacturer and PCB material.
2. PCB: .500 x.500 x .062; Construction: 1/2 oz Cu Top Layer; TLY-5A (.0075) 1/2 oz Cu Middle Layer, FR4; 1/2 oz Cu Bottom Layer. (dimensions are in inches)

Bill of Material

Reference Des.	Value	Description	Manuf.	Part Number
L1	20 nH	Chip Inductor, 0402, +/- 3 %	Murata	LQW15AN20NG00
L2	20 nH	Chip Inductor, 0402, +/- 3 %	Murata	LQW15AN20NG00
SMA	N/A	SMA connector	Radiall USA	9602-1111-018
PCB	N/A	3-layer	Multiple	961064

PCB Mounting Pattern

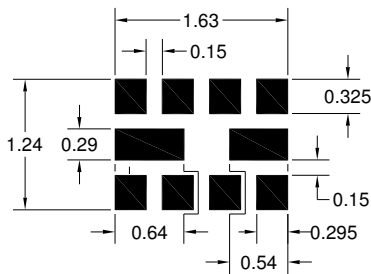

Notes:

1. All dimensions are in millimeters. Angles are in degrees.
2. This drawing specifies the mounting pattern used on the TriQuint evaluation board for this product. Some modification may be necessary to suit end user assembly materials and processes.

Performance Plots

Test conditions unless otherwise noted: Temp= +25°C

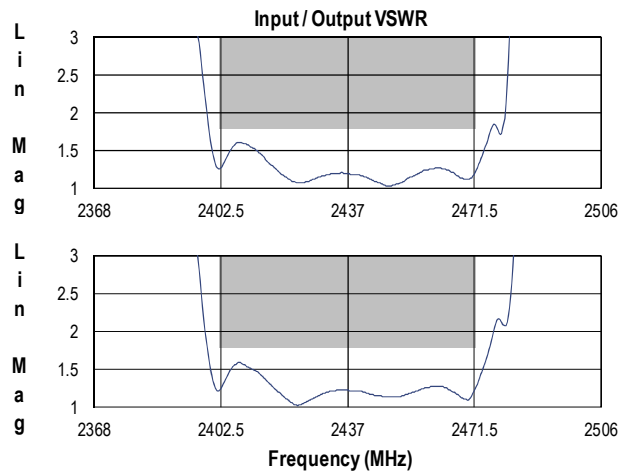
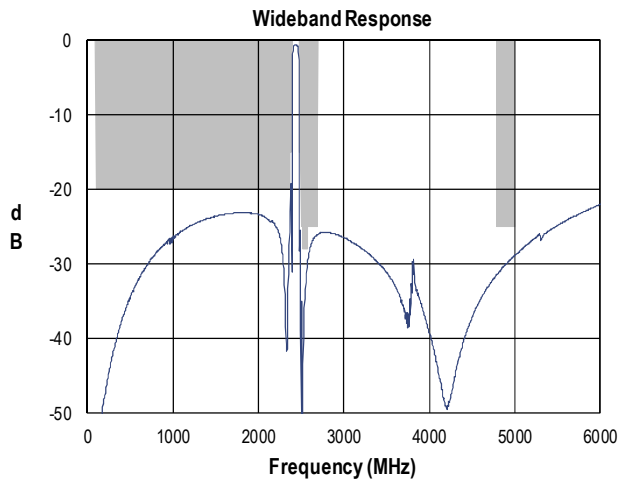
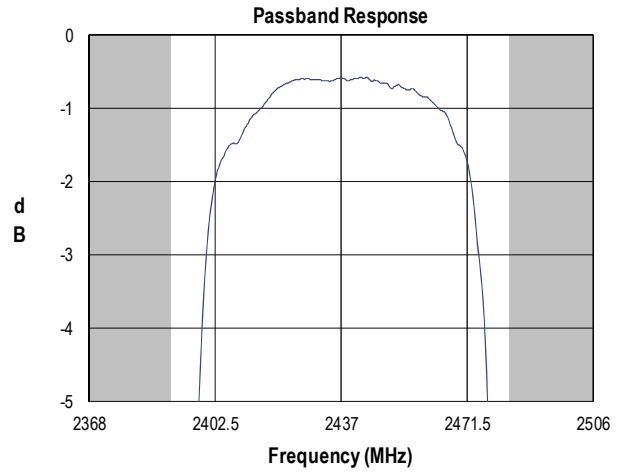
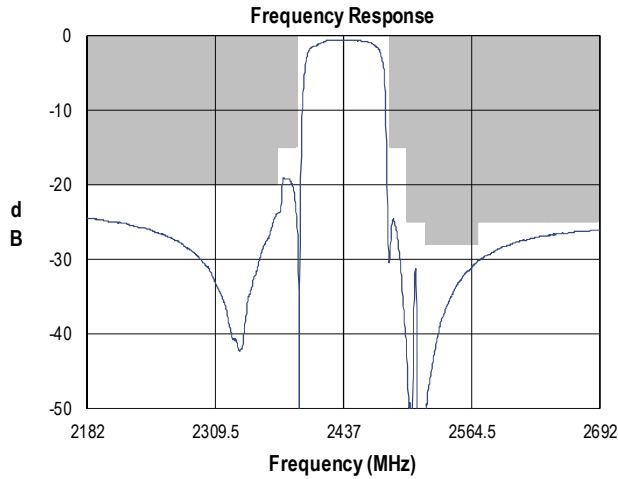

Input Smith Chart

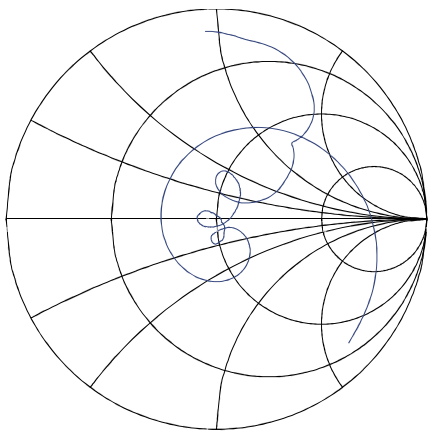

Output Smith Chart

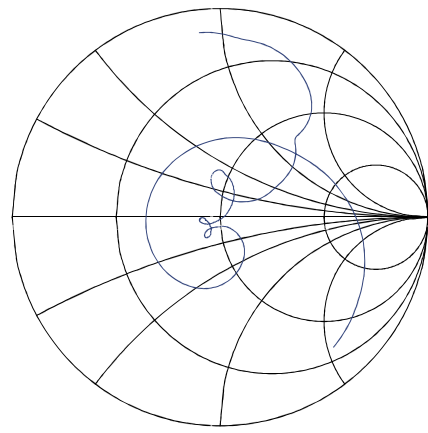

Package Information, Marking and Dimensions

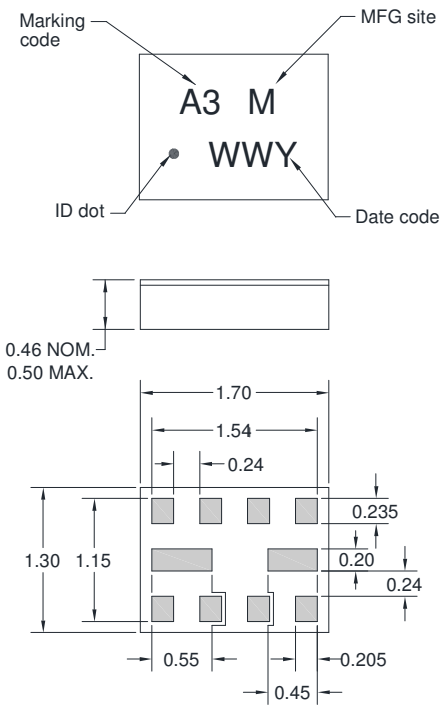

Package Style: CSP-1713
 Dimensions: 1.7 x 1.3 x 0.50 mm

Package for Surface Mount Technology
 Terminations: Au plating 0.5 - 1.0 μm , over a 2-6 μm Ni Plating.
 Approximate weight 3.96 mg

The Marking Code is correlated with the Part Number
 M=Manufacturing Site Code (Blank for Apopka, C for Costa Rica)
 The Date Code consists of: WW = 2 digit week, Y=The last digit of the year.

- Notes:
1. All dimensions shown are typical in millimeters.
 2. Unless otherwise specified all tolerances are $\pm 0.05\text{mm}$ except length and width that are specified as $\pm 0.1\text{mm}$.
 3. An asterisk (*) in front of the marking code indicates prototype.

Tape and Reel information

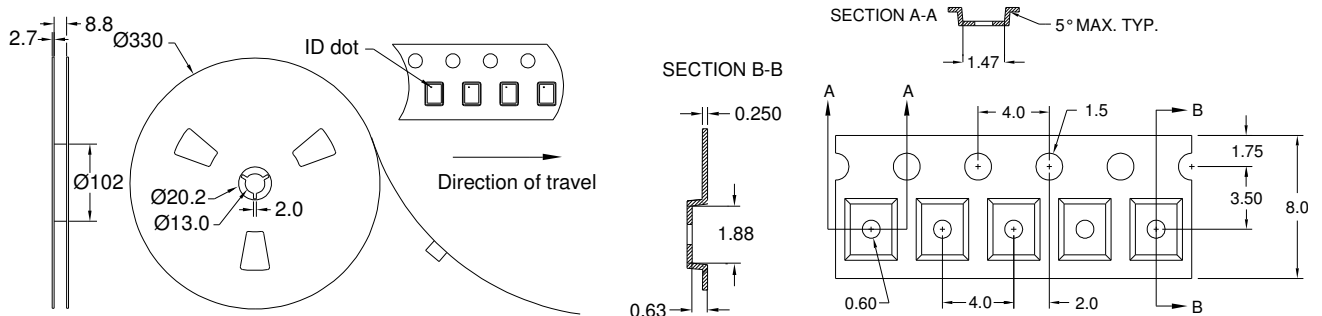

Standard T/R size=15,000 units/reel. All dimensions are in millimeters.

Product Compliance Information

ESD Sensitivity Ratings



Caution! ESD-Sensitive Device

ESD Rating: 2
Test: Human Body Model (HBM)
Standard: ESDA/JEDEC JS-001-2012

ESD Rating: C
Test: Machine Model (MM)
Standard: JEDEC Standard JESD22-A115

MSL Rating

Not applicable. Hermetic package.
Test: 260 °C convection reflow
Standard: JEDEC Standard IPC/JEDEC J-STD-020

Solderability

Compatible with the latest version of J-STD-020, lead free solder, 260 °C

Refer to [Soldering Profile](#) for recommended guidelines.

RoHS Compliance

This part is compliant with EU 2002/95/EC RoHS directive (Restrictions on the Use of Certain Hazardous Substances in Electrical and Electronic Equipment).

This product also has the following attributes:

- Halogen Free (Chlorine, Bromine)
- Antimony Free
- TBBP-A (C₁₅H₁₂Br₄O₂) Free
- PFOS Free
- SVHC Free

Contact Information

For the latest specifications, additional product information, worldwide sales and distribution locations:

Web: www.triquint.com **Tel:** **Tel: 877-800-8584**
Email: customer.support@qorvo.com

For information about the merger of RFMD and TriQuint as Qorvo:

Web: www.qorvo.com

For technical questions and application information: **Email:** fapplication.engineering@tqs.com

Important Notice

The information contained herein is believed to be reliable. TriQuint makes no warranties regarding the information contained herein. TriQuint assumes no responsibility or liability whatsoever for any of the information contained herein. TriQuint assumes no responsibility or liability whatsoever for the use of the information contained herein. The information contained herein is provided "AS IS, WHERE IS" and with all faults, and the entire risk associated with such information is entirely with the user. All information contained herein is subject to change without notice. Customers should obtain and verify the latest relevant information before placing orders for TriQuint products. The information contained herein or any use of such information does not grant, explicitly or implicitly, to any party any patent rights, licenses, or any other intellectual property rights, whether with regard to such information itself or anything described by such information.

TriQuint products are not warranted or authorized for use as critical components in medical, life-saving, or life-sustaining applications, or other applications where a failure would reasonably be expected to cause severe personal injury or death.