



SAW components

SAW Rx filter LTE band 3

Series/type:	B8812
Ordering code:	B39182B8812P810
Date:	February 12, 2016
Version:	2.2

SAW components	B8812
SAW Rx filter	1842.5 MHz

Data sheet

Table of contents

1 Application	3
2 Features	3
3 Package	4
4 Pin configuration	4
5 Matching circuit	5
6 Characteristics	6
7 Maximum ratings	7
8 Transmission coefficient	8
9 Reflection coefficients	9
10 Packing material	10
11 Marking	13
12 Soldering profile	15
13 Annotations	16
14 Cautions and warnings	17
Important notes	18

Data sheet

1 Application

- Low-loss RF filter for mobile telephone LTE and WCDMA Band 3 receive path (RX)
- Usable pass band: 75 MHz
- Impedance at input and output 50Ω
- Unbalanced to unbalanced operation

2 Features

- Package size 1.1±0.1 mm × 0.9±0.1 mm
- Package height 0.45 mm (max.)
- Approximate weight 0.001 g
- RoHS compatible
- Package for Surface Mount Technology (SMT)
- Ni/Au-plated terminals
- Electrostatic Sensitive Device (ESD)
- Moisture Sensitivity Level 3 (MSL3)

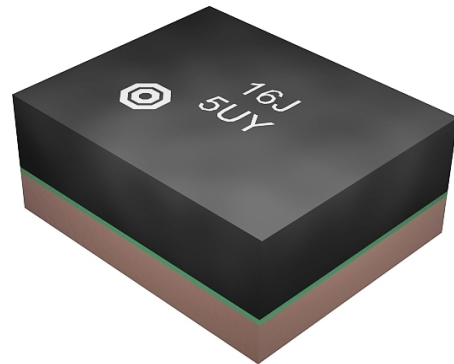
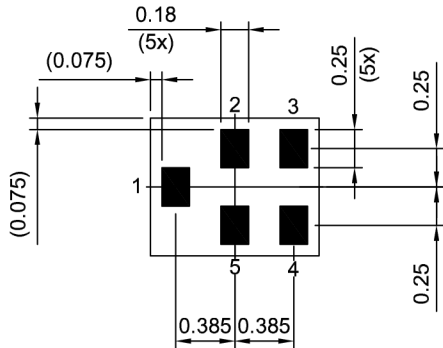

Figure 1: Picture of component with example of product marking.

Data sheet

3 Package

BOTTOM VIEW



Pad and pitch tolerance ±0.05

4 Pin configuration

- 1 Input
- 4 Output
- 2, 3, 5 Ground

SIDE VIEW

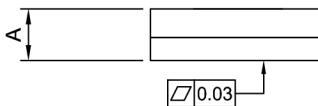

TOP VIEW

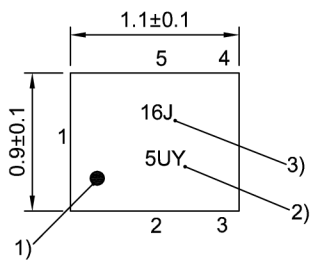

- 1) Marking for pad number 1
- 2) Example of encoded lot number
- 3) Example of encoded filter type number

Land pattern THRU VIEW

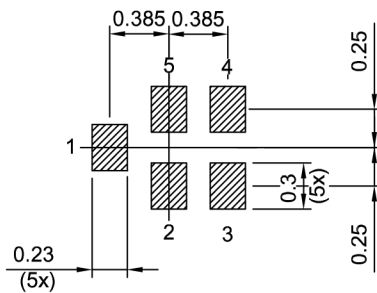

Landing pad tolerance -0.02

Figure 2: Drawing of package with package height A = 0.45 mm (max.). See Simplified drawings (p. 17).

Data sheet

5 Matching circuit

■ $L_{s1} = 2.0 \text{ nH}$

■ $L_{s4} = 2.0 \text{ nH}$

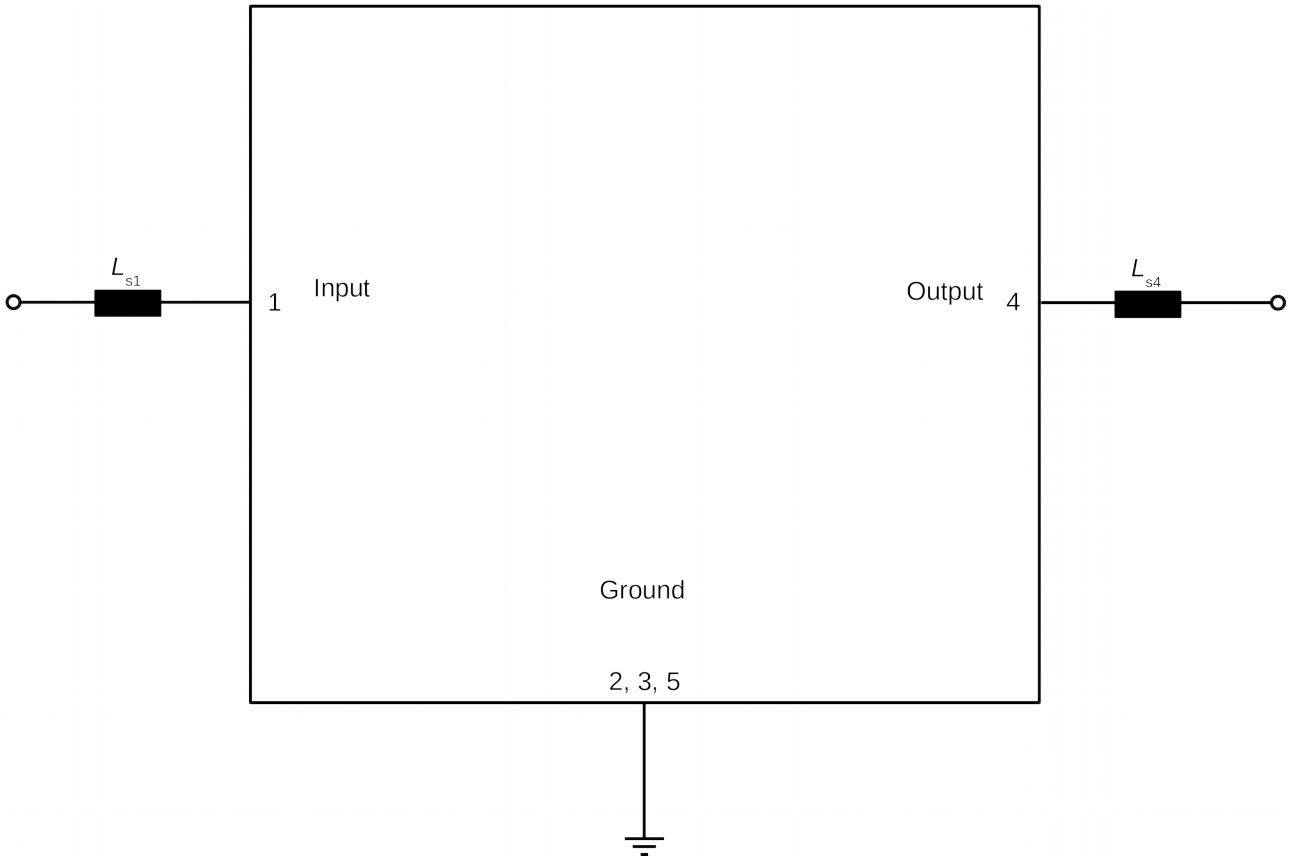

Figure 3: Schematic of matching circuit.

Data sheet

6 Characteristics

Temperature range for specification

 $T = -20\text{ °C} \dots +85\text{ °C}$

Input terminating impedance

 $Z_{\text{Input}} = 50\ \Omega$ with ser. 2.0 nH¹⁾

Output terminating impedance

 $Z_{\text{Output}} = 50\ \Omega$ with ser. 2.0 nH¹⁾

Characteristics					min.	typ. @+25 °C	max.	
Center frequency				f_c	—	1842.5	—	MHz
Maximum insertion attenuation								
		1805... 1880	MHz	α_{max}	—	2.0	3.0	dB
	@ f_{carrier}	1807.4... 1877.6	MHz	$\alpha_{\text{WCDMA,max}}^{2)}$	—	1.7	2.4	dB
Amplitude ripple (p-p)				$\Delta\alpha$				
		1805... 1880	MHz		—	1.1	2.1	dB
Maximum VSWR				VSWR _{max}				
	@ Input port	1805... 1880	MHz		—	1.6	2.0	
	@ Output port	1805... 1880	MHz		—	1.6	2.0	
Minimum attenuation								
		10... 824	MHz	α_{min}	32	36	—	dB
		824... 849	MHz	α_{min}	32	36	—	dB
		832... 862	MHz	α_{min}	32	36	—	dB
		880... 915	MHz	α_{min}	32	36	—	dB
		915... 1710	MHz	α_{min}	32	35	—	dB
		1710... 1785	MHz	α_{min}	32	42	—	dB
	@ f_{carrier}	1712.4... 1782.6	MHz	$\alpha_{\text{WCDMA,min}}^{2)}$	38	42	—	dB
		1940... 2400	MHz	α_{min}	30	35	—	dB
		2400... 2500	MHz	α_{min}	30	35	—	dB
		2500... 2570	MHz	α_{min}	30	35	—	dB
		2570... 4900	MHz	α_{min}	25	32	—	dB
		4900... 5415	MHz	α_{min}	25	29	—	dB
		5415... 5640	MHz	α_{min}	25	29	—	dB
		5640... 5950	MHz	α_{min}	25	30	—	dB

¹⁾ See Matching circuit (p. 5).

²⁾ Attenuation of WCDMA signal ("power transfer function"). Please refer to definition of Power Transfer Function (PTF) of WCDMA signal (p. 16).

SAW components	B8812
SAW Rx filter	1842.5 MHz

Data sheet

7 Maximum ratings

Storage temperature	$T_{STG} = -40\text{ °C} \dots +85\text{ °C}^{1)}$	
DC voltage	$V_{DC} = 5.0\text{ V (max.)}^{2)}$	
ESD voltage		
	$V_{ESD}^{3)}$ 50 V (max.)	Machine model.
	$V_{ESD}^{4)}$ 200 V (max.)	Human body model.
	$V_{ESD}^{5)}$ 600 V (max.)	Charged device model.
Input power @ Input port: 1710 ... 1785 MHz	$P_{IN} = 12\text{ dBm}$	Continuous wave for 2000 h @ 55 °C.

¹⁾ Extended upper limit: 96h@125°C acc. to IEC 60068-2-2 Bb.

²⁾ 168h Damp Heat Steady State acc. IEC 60068-2-67 Cy.

³⁾ According to JESD22-A115B (MM – Machine Model), 10 negative & 10 positive pulses.

⁴⁾ According to JESD22-A114F (HBM – Human Body Model), 1 negative & 1 positive pulse.

⁵⁾ According to JESD22-C101C (CDM – Field Induced Charged Device Model), 3 negative & 3 positive pulses.

Data sheet

8 Transmission coefficient

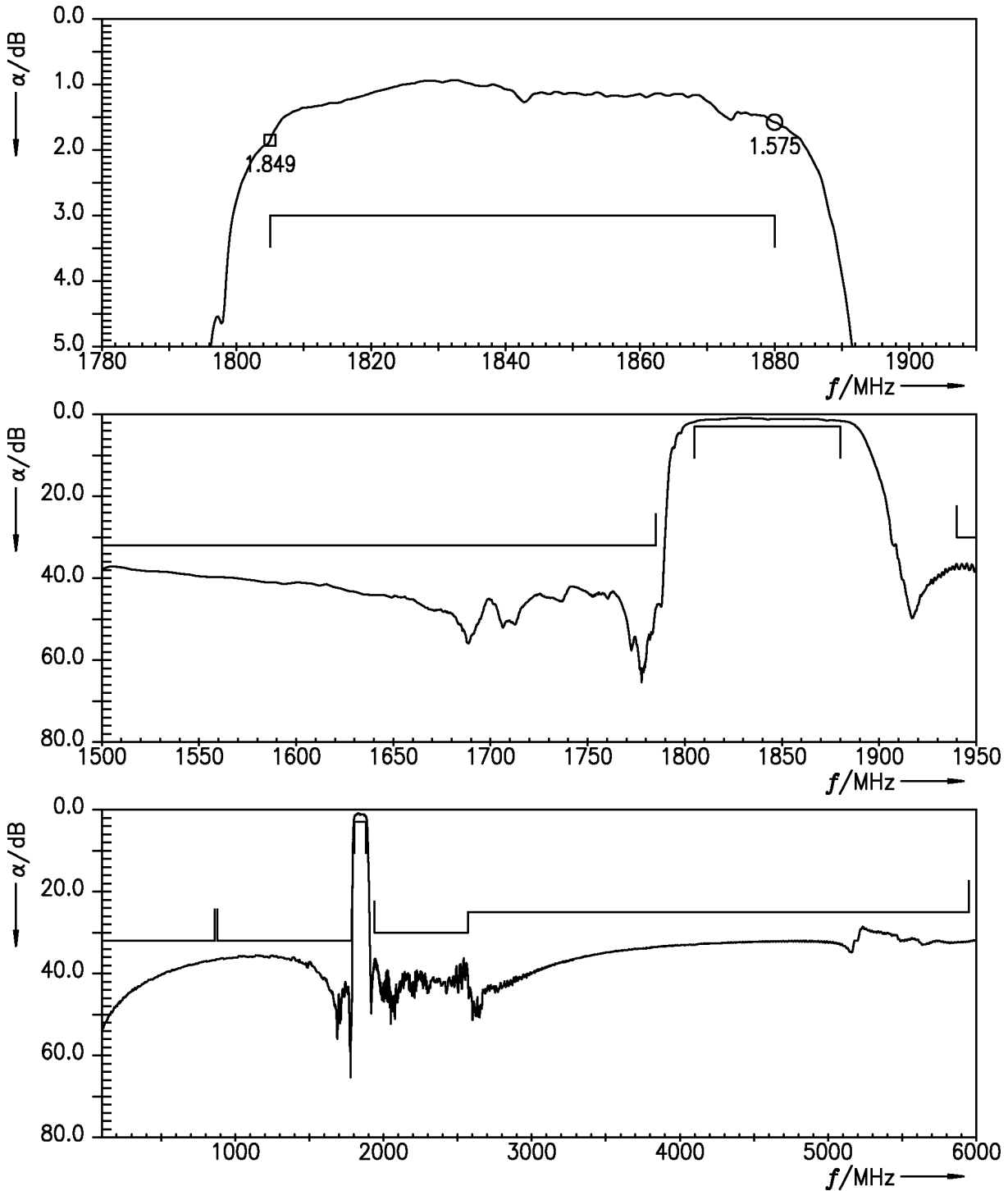

Figure 4: Attenuation.

Data sheet

9 Reflection coefficients

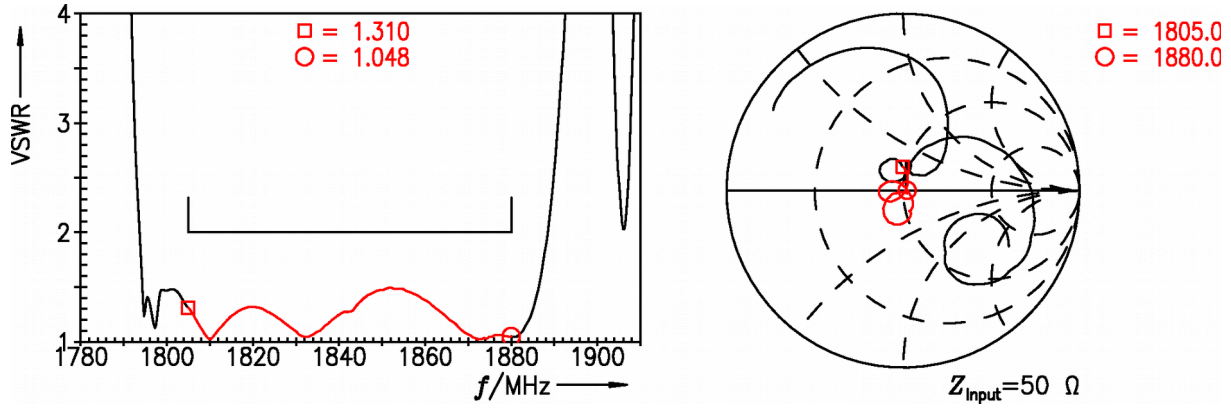

Figure 5: Reflection coefficient at IN port.

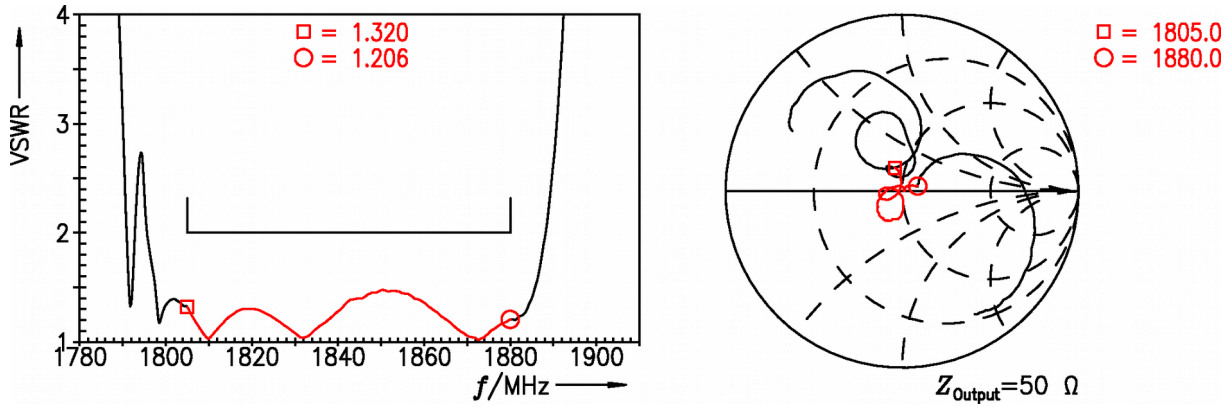

Figure 6: Reflection coefficient at OUT port.

Data sheet

10 Packing material

10.1 Tape

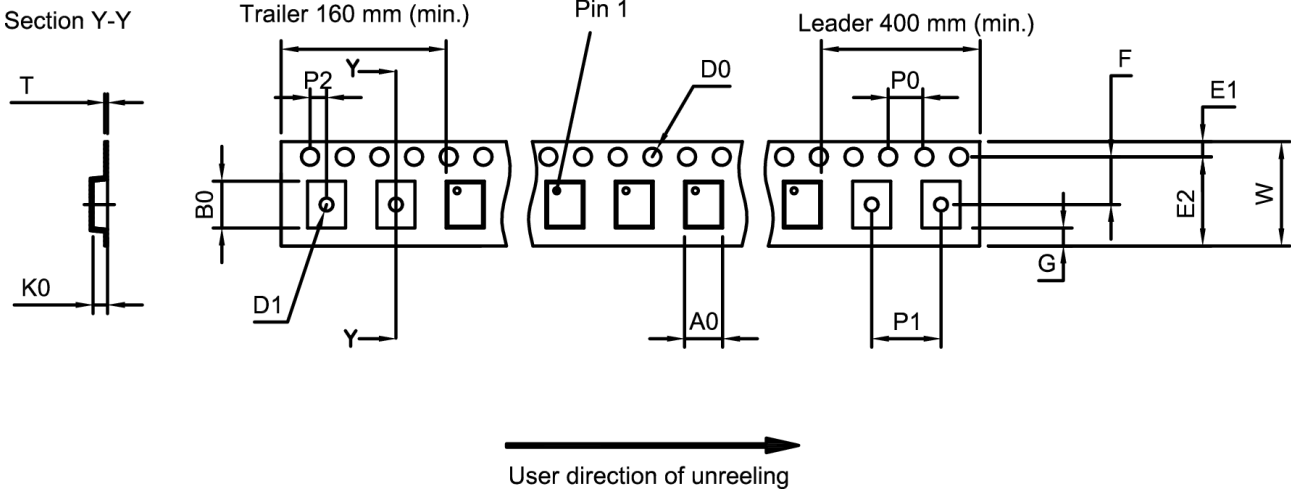

Figure 7: Drawing of tape (first-angle projection) with tape dimensions according to Table 1.

A ₀	1.02±0.05 mm	E ₂	6.25 mm (min.)	P ₁	2.0±0.1 mm
B ₀	1.22±0.05 mm	F	3.5±0.05 mm	P ₂	2.0±0.05 mm
D ₀	1.55±0.05 mm	G	–	T	0.25±0.03 mm
D ₁	0.55±0.1 mm	K ₀	0.6±0.05 mm	W	8.0+0.3/-0.1 mm
E ₁	1.75±0.1 mm	P ₀	4.0±0.1 mm		

Table 1: Tape dimensions.

10.2 Reel with diameter of 180 mm

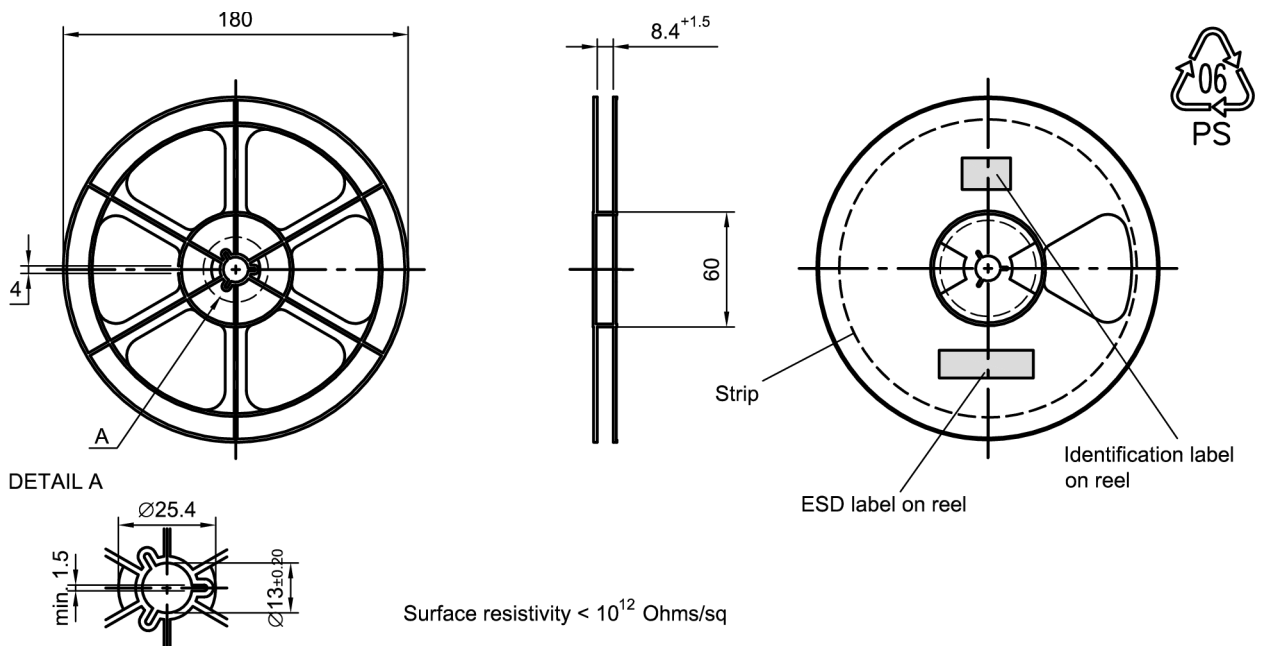

Figure 8: Drawing of reel (first-angle projection) with diameter of 180 mm.

Data sheet

Dimensions [mm]
 X = 220±5
 Y = 235±5
 Sealing area 10±3

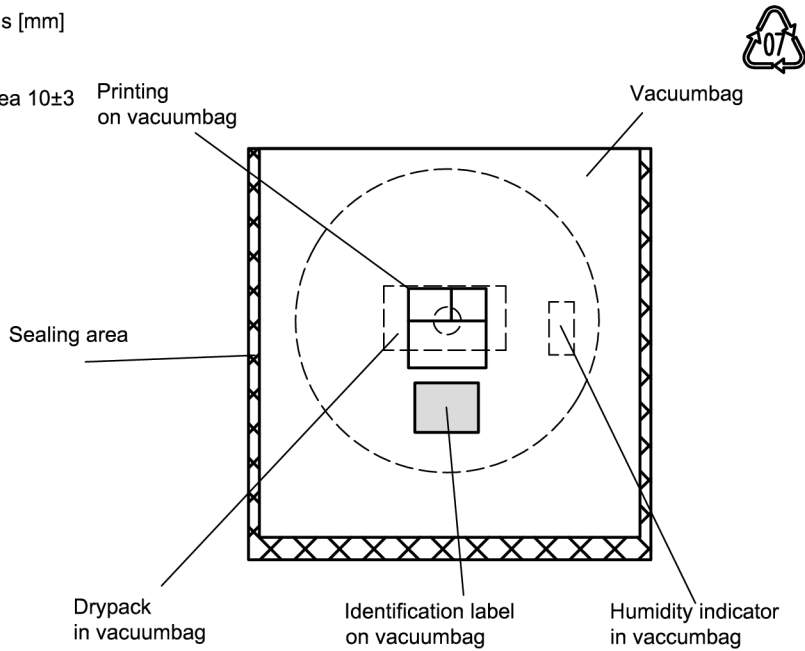

Figure 9: Drawing of moisture barrier bag (MBB) for reel with diameter of 180 mm.

Dimensions [mm]
 L = 188
 B = 188
 H = 30
 Tolerance ±5

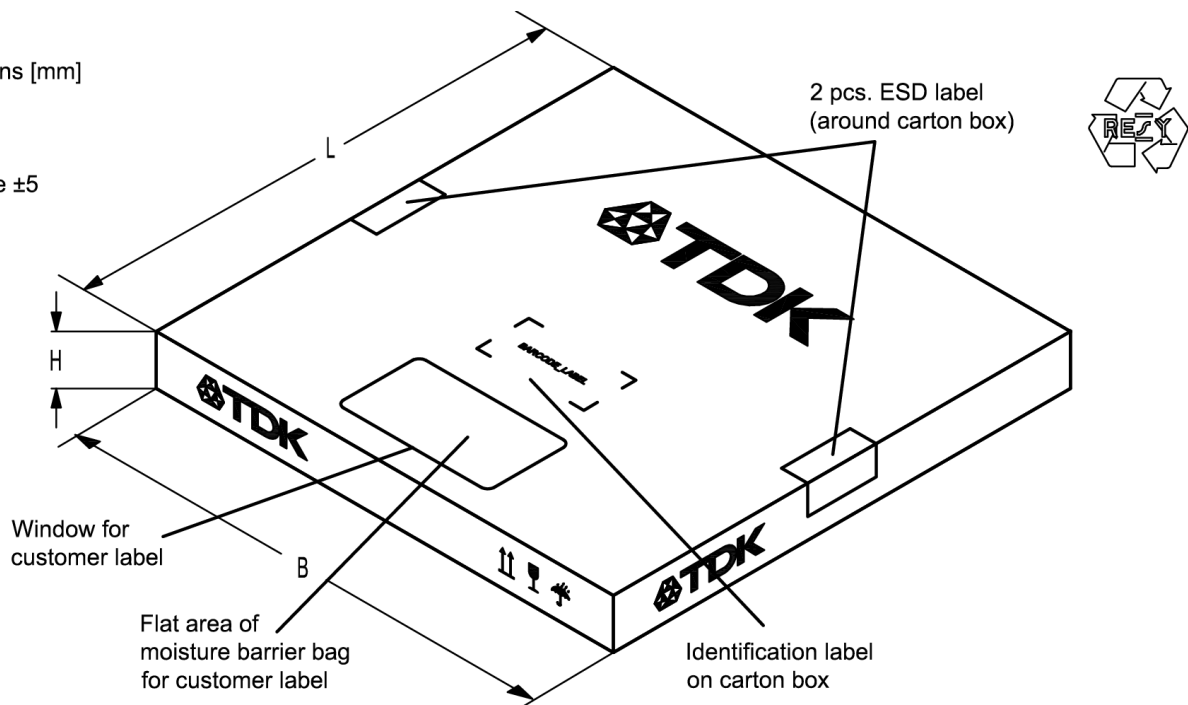

Figure 10: Drawing of folding box for reel with diameter of 180 mm.

Data sheet

10.3 Reel with diameter of 330 mm

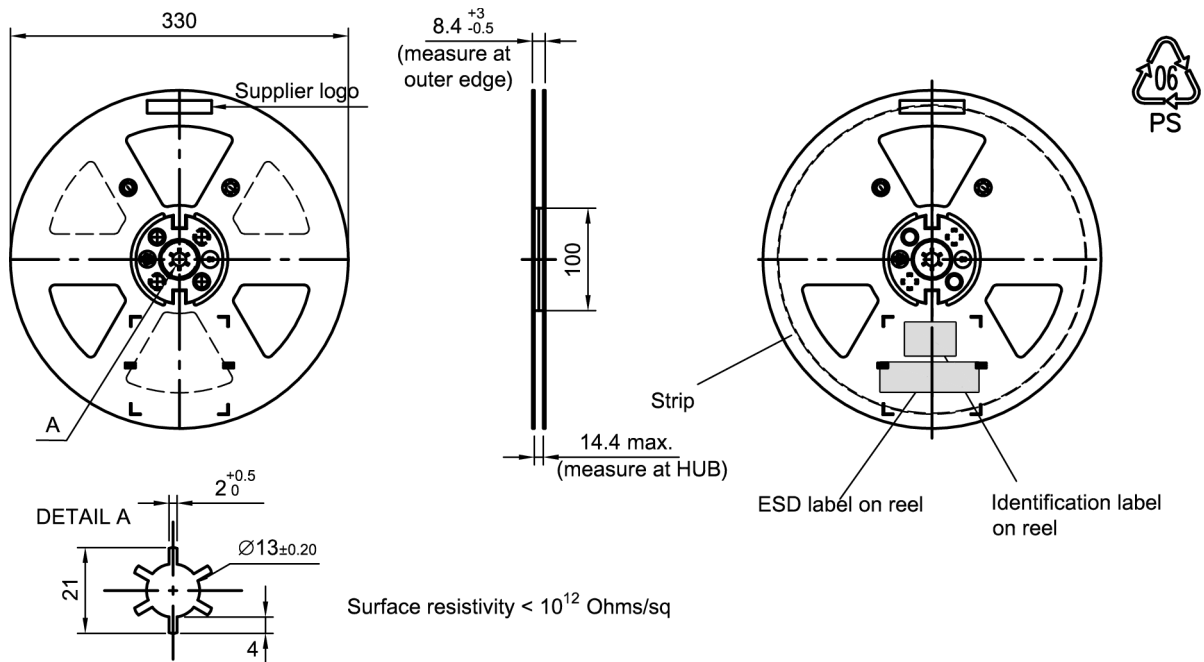

Figure 11: Drawing of reel (first-angle projection) with diameter of 330 mm.

Dimensions [mm]
 X = 400+5
 Y = 418+5
 Sealing area 10±3

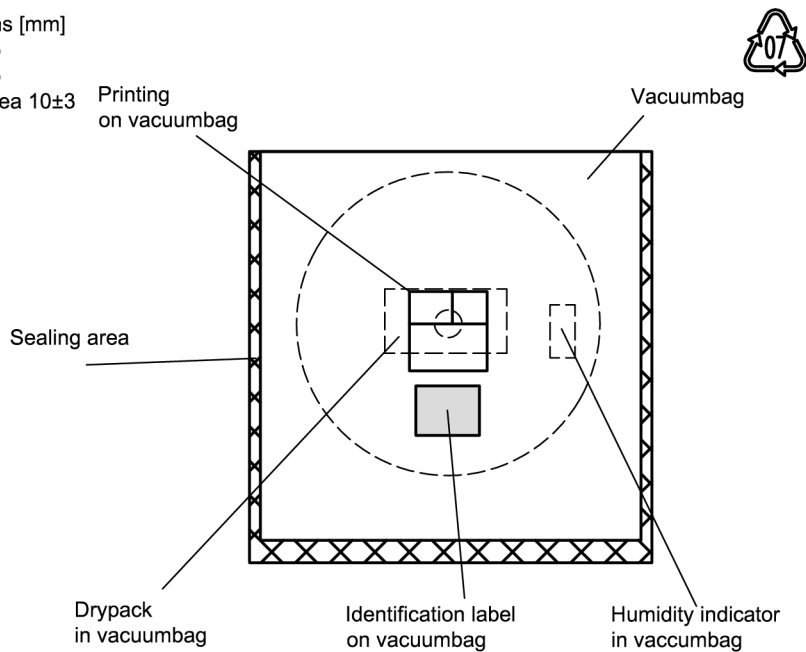

Figure 12: Drawing of moisture barrier bag (MBB) for reel with diameter of 330 mm.

Data sheet

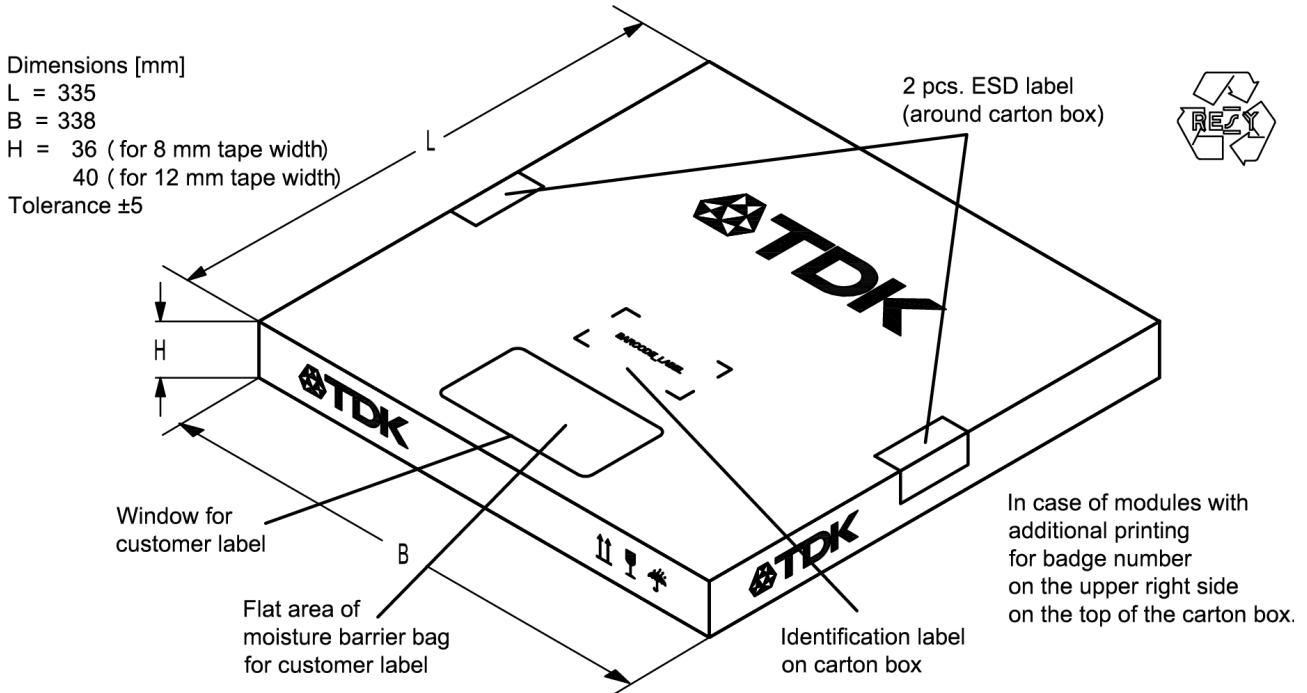

Figure 13: Drawing of folding box for reel with diameter of 330 mm.

11 Marking

Products are marked with product type number and lot number encoded according to Table 2:

■ Type number:

The 4 digit type number of the ordering code, e.g., B3xxxxB**1234**xxxx,
is encoded by a special BASE32 code into a 3 digit marking.

Example of decoding type number marking on device in decimal code.
 $16J \Rightarrow 1234$
 $1 \times 32^2 + 6 \times 32^1 + 18 (=J) \times 32^0 = 1234$

The BASE32 code for product type B8812 is 8KC.

■ Lot number:

The last 5 digits of the lot number, e.g., **12345**,
are encoded based on a special BASE47 code into a 3 digit marking.

Example of decoding lot number marking on device in decimal code.
 $5UY \Rightarrow 12345$
 $5 \times 47^2 + 27 (=U) \times 47^1 + 31 (=Y) \times 47^0 = 12345$

Data sheet

Adopted BASE32 code for type number			
Decimal value	Base32 code	Decimal value	Base32 code
0	0	16	G
1	1	17	H
2	2	18	J
3	3	19	K
4	4	20	M
5	5	21	N
6	6	22	P
7	7	23	Q
8	8	24	R
9	9	25	S
10	A	26	T
11	B	27	V
12	C	28	W
13	D	29	X
14	E	30	Y
15	F	31	Z

Adopted BASE47 code for lot number			
Decimal value	Base47 code	Decimal value	Base47 code
0	0	24	R
1	1	25	S
2	2	26	T
3	3	27	U
4	4	28	V
5	5	29	W
6	6	30	X
7	7	31	Y
8	8	32	Z
9	9	33	b
10	A	34	d
11	B	35	f
12	C	36	h
13	D	37	n
14	E	38	r
15	F	39	t
16	G	40	v
17	H	41	\
18	J	42	?
19	K	43	{
20	L	44	}
21	M	45	<
22	N	46	>
23	P		

Table 2: Lists for encoding and decoding of marking.

SAW components	B8812
SAW Rx filter	1842.5 MHz

Data sheet

12 Soldering profile

The recommended soldering process is in accordance with IEC 60068-2-58 – 3rd edit and IPC/JEDEC J-STD-020B.

ramp rate	≤ 3 K/s
preheat	125 °C to 220 °C, 150 s to 210 s, 0.4 K/s to 1.0 K/s
$T > 220\text{ °C}$	30 s to 70 s
$T > 230\text{ °C}$	min. 10 s
$T > 245\text{ °C}$	max. 20 s
$T \geq 255\text{ °C}$	–
peak temperature T_{peak}	250 °C +0/-5 °C
wetting temperature T_{min}	230 °C +5/-0 °C for 10 s ± 1 s
cooling rate	≤ 3 K/s
soldering temperature T	measured at solder pads

Table 3: Characteristics of recommended soldering profile for lead-free solder (Sn95.5Ag3.8Cu0.7).

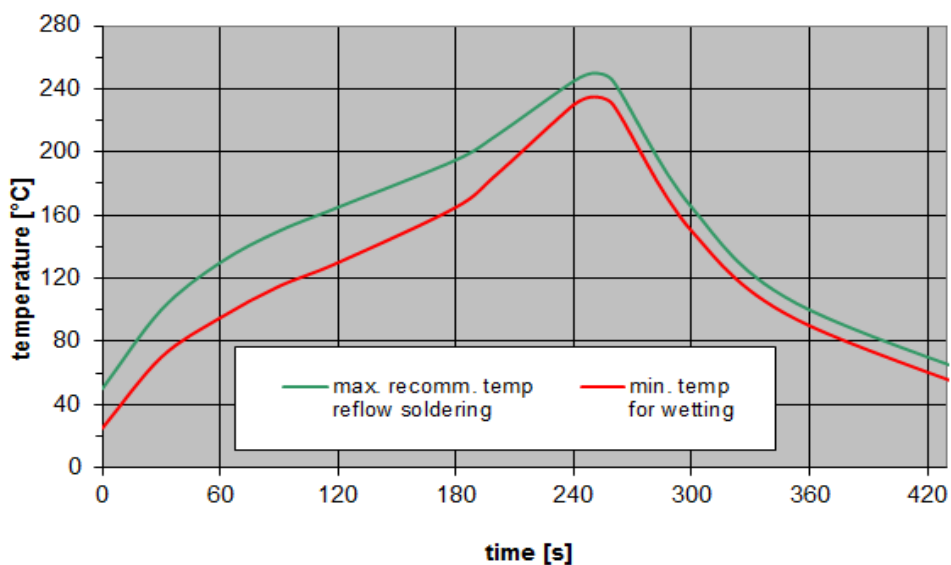

Figure 14: Recommended reflow profile for convection and infrared soldering – lead-free solder.

SAW components	B8812
SAW Rx filter	1842.5 MHz

Data sheet

13 Annotations

13.1 Matching coils

See TDK inductor pdf-catalog <http://www.tdk.co.jp/tefe02/coil.htm#aname1> and Data Library for circuit simulation <http://www.tdk.co.jp/etvcl/index.htm>.

13.2 Power Transfer Function (PTF) of WCDMA signal

Attenuation of WCDMA signal, α_{WCDMA} , is defined by

$$\alpha_{\text{WCDMA}}(f_{\text{carrier}}) = 10 \log_{10} \left| \frac{1}{\text{PTF}(f_{\text{carrier}})} \right| \text{dB}$$

and

$$\text{PTF}(f_{\text{carrier}}) = \int_{-\infty}^{+\infty} |S_{21}(f) H_{\text{RRC}}(f - f_{\text{carrier}})|^2 df$$

with f_{carrier} according to 3GPP TS 25.101 (e.g., for the WCDMA B8 pass band, f_{carrier} ranges from 882.4 MHz to 912.6 MHz which correspond to the lowest and highest TX channels, respectively). $H_{\text{RRC}}(f)$ is the transfer function of the root-raised cosine transmit pulse shaping filter according to 3GPP TS 25.101 using the normalization

$$\int_{-\infty}^{+\infty} |H_{\text{RRC}}(f)|^2 df = 1 \quad .$$

13.3 RoHS compatibility

ROHS-compatible means that products are compatible with the requirements according to Art. 4 (substance restrictions) of Directive 2011/65/EU of the European Parliament and of the Council of June 8th, 2011, on the restriction of the use of certain hazardous substances in electrical and electronic equipment ("Directive") with due regard to the application of exemptions as per Annex III of the Directive in certain cases.

13.4 Scattering parameters (S-parameters)

The pin/port assignment is available in the headers of the S-parameter files. Please contact your local EPCOS sales office.

13.5 Ordering codes and packing units

Ordering code	Packing unit
B39182B8812P810	15000 pcs
B39182B8812P810S 5	5000 pcs

Table 4: Ordering codes and packing units.

Data sheet

14 Cautions and warnings

14.1 Display of ordering codes for EPCOS products

The ordering code for one and the same product can be represented differently in data sheets, data books, other publications and the website of EPCOS, or in order-related documents such as shipping notes, order confirmations and product labels. The varying representations of the ordering codes are due to different processes employed and do not affect the specifications of the respective products. Detailed information can be found on the Internet under www.epcos.com/orderingcodes.

14.2 Material information

Due to technical requirements components may contain dangerous substances. For information on the type in question please also contact one of our sales offices.

14.3 Moldability

Before using in overmolding environment, please contact your local EPCOS sales office.

14.4 Simplified drawings

Landing area

The printed circuit board (PCB) land pattern (landing area) shown is based on EPCOS internal development and empirical data and illustrated for example purposes, only. As customers' SMD assembly processes may have a plenty of variants and influence factors which are not under control or knowledge of EPCOS, additional careful process development on customer side is necessary and strongly recommended in order to achieve best soldering results tailored to the particular customer needs.

Dimensions

Unless otherwise specified all dimensions are understood using unit millimeter (mm).

Projection method

Unless otherwise specified first-angle projection is applied.

Important notes

The following applies to all products named in this publication:

1. Some parts of this publication contain **statements about the suitability of our products for certain areas of application**. These statements are based on our knowledge of typical requirements that are often placed on our products in the areas of application concerned. We nevertheless expressly point out **that such statements cannot be regarded as binding statements about the suitability of our products for a particular customer application**. As a rule, EPCOS is either unfamiliar with individual customer applications or less familiar with them than the customers themselves. For these reasons, it is always ultimately incumbent on the customer to check and decide whether an EPCOS product with the properties described in the product specification is suitable for use in a particular customer application.
2. We also point out that **in individual cases, a malfunction of electronic components or failure before the end of their usual service life cannot be completely ruled out in the current state of the art, even if they are operated as specified**. In customer applications requiring a very high level of operational safety and especially in customer applications in which the malfunction or failure of an electronic component could endanger human life or health (e.g. in accident prevention or life-saving systems), it must therefore be ensured by means of suitable design of the customer application or other action taken by the customer (e.g. installation of protective circuitry or redundancy) that no injury or damage is sustained by third parties in the event of malfunction or failure of an electronic component.
3. **The warnings, cautions and product-specific notes must be observed.**
4. In order to satisfy certain technical requirements, **some of the products described in this publication may contain substances subject to restrictions in certain jurisdictions (e.g. because they are classed as hazardous)**. Useful information on this will be found in our Material Data Sheets on the Internet (www.epcos.com/material). Should you have any more detailed questions, please contact our sales offices.
5. We constantly strive to improve our products. Consequently, **the products described in this publication may change from time to time**. The same is true of the corresponding product specifications. Please check therefore to what extent product descriptions and specifications contained in this publication are still applicable before or when you place an order. We also **reserve the right to discontinue production and delivery of products**. Consequently, we cannot guarantee that all products named in this publication will always be available.
The aforementioned does not apply in the case of individual agreements deviating from the foregoing for customer-specific products.
6. Unless otherwise agreed in individual contracts, **all orders are subject to the current version of the “General Terms of Delivery for Products and Services in the Electrical Industry” published by the German Electrical and Electronics Industry Association (ZVEI)**.
7. The trade names EPCOS, Alu-X, CeraDiode, CeraLink, CeraPad, CeraPlas, CSMP, CSSP, CTVS, DeltaCap, DigiSiMic, DSSP, ExoCore, FilterCap, FormFit, LeaXield, MiniBlue, MiniCell, MKD, MKK, MotorCap, PCC, PhaseCap, PhaseCube, PhaseMod, PhiCap, PQSine, SIFERRIT, SIFI, SIKOREL, SilverCap, SIMDAD, SiMic, SIMID, SineFormer, SIOV, SIP5D, SIP5K, TFAP, ThermoFuse, WindCap are **trademarks registered or pending** in Europe and in other countries. Further information will be found on the Internet at www.epcos.com/trademarks.