



SAW components

BAW/SAW duplexer for small cell LTE band 7

Series/type:	B8032
Ordering code:	B39262B8032P810
Date:	March 23, 2016
Version:	2.1

© EPCOS AG 2016. Reproduction, publication and dissemination of this data sheet, enclosures hereto and the information contained therein without EPCOS' prior express consent is prohibited.

EPCOS AG is a TDK Group Company.

Data sheet

Table of contents

1 Application	3
2 Features	3
3 Package	4
4 Pin configuration	4
5 Matching circuit	5
6 Characteristics	6
7 Maximum ratings	9
8 Transmission coefficients	10
9 Reflection coefficients	13
10 EVMS	14
11 Packing material	16
12 Marking	19
13 Soldering profile	21
14 Annotations	22
15 Cautions and warnings	23
Important notes	24

Data sheet

1 Application

- Low-loss BAW/SAW hybrid duplexer for LTE smallcell systems (Band 7)
- Low insertion attenuation
- High power durability
- Industrial qualification
- Usable pass band 70 MHz
- Rx = Uplink = 2500-2570 MHz
- Tx = Downlink = 2620-2690 MHz

2 Features

- Package size 2.5±0.1 mm × 2.0±0.1 mm
- Package height 0.5 mm (max.)
- Approximate weight 8 mg
- RoHS compatible
- Package for Surface Mount Technology (SMT)
- Ni/Au-plated terminals
- Electrostatic Sensitive Device (ESD)
- Moisture Sensitivity Level 2a (MSL2a)

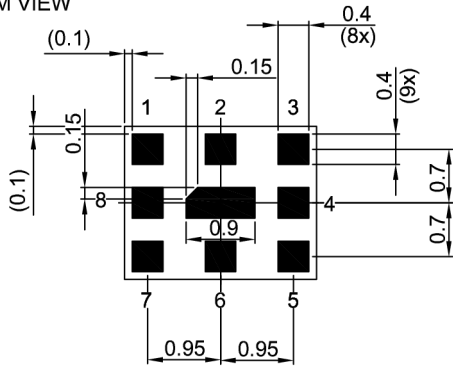

Figure 1: Picture of component with example of product marking.

Data sheet

3 Package

BOTTOM VIEW



Pad and pitch tolerance ±0.05

SIDE VIEW

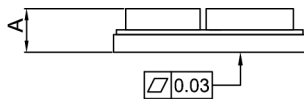

TOP VIEW

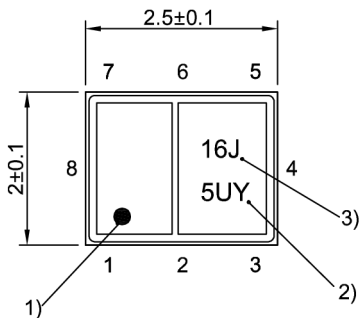

- 1) Marking for pad number 1
- 2) Example of encoded lot number
- 3) Example of encoded filter type number

Land pattern THRU VIEW

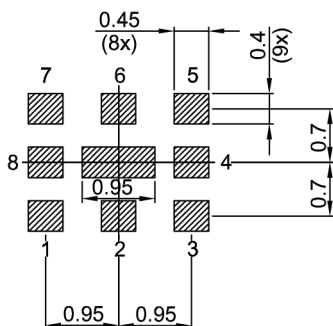

Landing pad tolerance -0.02

Figure 2: Drawing of package with package height A = 0.5 mm (max.). See Sec. Package information (p. 23).

4 Pin configuration

- 1 TX
- 3 RX
- 6 ANT
- 2, Ground
- 4, 5,
- 7, 8, 9

Data sheet

5 Matching circuit

- $L_{p1} = 4.7 \text{ nH}$
- $L_{p3} = 4.3 \text{ nH}$

- $L_{p6} = 2.2 \text{ nH}$

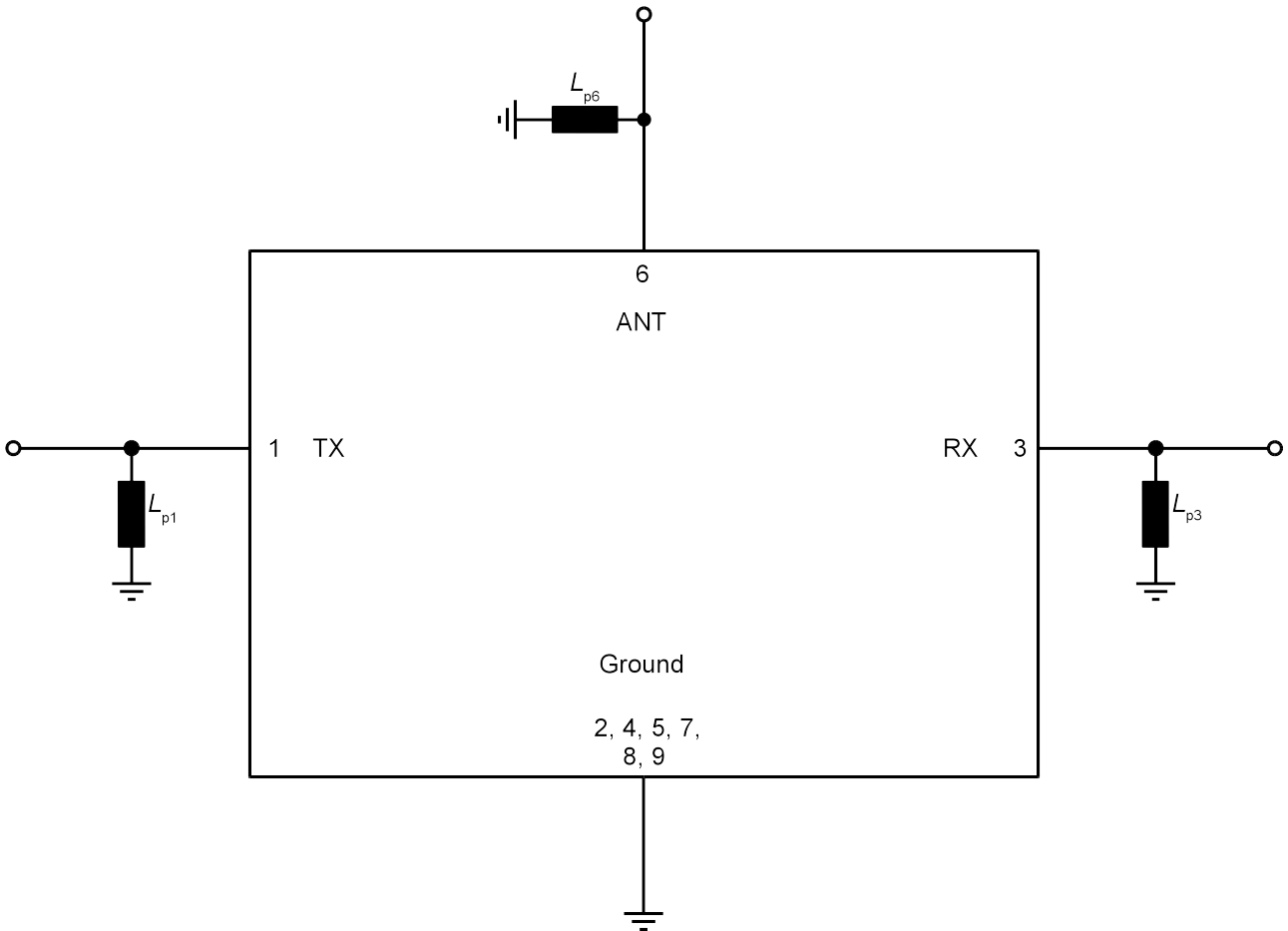

Figure 3: Schematic of matching circuit.

Data sheet

6 Characteristics

6.1 TX – ANT

Temperature range for specification	T_{SPEC}	= -10 °C ... +85 °C
TX terminating impedance	Z_{TX}	= 50 Ω with par. 4.7 nH ¹⁾
ANT terminating impedance	Z_{ANT}	= 50 Ω with par. 2.2 nH ¹⁾
RX terminating impedance	Z_{RX}	= 50 Ω with par. 4.3 nH ¹⁾

Characteristics TX – ANT				min. for T_{SPEC}	typ. @+25 °C	max. for T_{SPEC}	
Center frequency			f_C	—	2655	—	MHz
Maximum insertion attenuation	2620... 2690	MHz	α_{max}	—	2.0	3.0	dB
Amplitude ripple (p-p)	2620... 2690	MHz	$\Delta\alpha$	—	0.4	1.5	dB
Maximum VSWR			VSWR _{max}				
@ TX port	2620... 2690	MHz		—	1.4	2.0	
@ ANT port	2620... 2690	MHz		—	1.4	2.0	
Average error vector magnitude	2622.4... 2687.6	MHz	EVM _{avg} ²⁾	—	1.1	2.0	%
Minimum attenuation			α_{min}				
	10... 1710	MHz		30	38	—	dB
	1710... 1785	MHz		35	37	—	dB
	1920... 1980	MHz		35	38	—	dB
	2270... 2300	MHz		35	38	—	dB
	2300... 2400	MHz		35	39	—	dB
	2400... 2500	MHz		35	44	—	dB
	2500... 2570	MHz		38	43	—	dB
	2770... 3200	MHz		38	43	—	dB
	3200... 4350	MHz		40	45	—	dB
	4350... 6000	MHz		35	40	—	dB

¹⁾ See Sec. Matching circuit (p. 5).

²⁾ Error Vector Magnitude (EVM) based on definition given in 3GPP TS 25.141.

Data sheet

6.2 ANT – RX

Temperature range for specification	T_{SPEC}	= -10 °C ... +85 °C
TX terminating impedance	Z_{TX}	= 50 Ω with par. 4.7 nH ¹⁾
ANT terminating impedance	Z_{ANT}	= 50 Ω with par. 2.2 nH ¹⁾
RX terminating impedance	Z_{RX}	= 50 Ω with par. 4.3 nH ¹⁾

Characteristics ANT – RX	min. for T_{SPEC}	typ. @+25 °C	max. for T_{SPEC}	
Center frequency	—	2535	—	MHz
Maximum insertion attenuation	—	3.0 ²⁾	4.0 ²⁾	dB
	—	3.0	4.5	dB
Amplitude ripple (p-p)	—	1.4 ²⁾	2.5 ²⁾	dB
	—	1.4	3.0	dB
Maximum VSWR	—	1.7 ²⁾	2.2 ²⁾	dB
@ ANT port	—	1.7	2.3	dB
@ RX port	—	1.3	2.0	dB
Average error vector magnitude	—	2.1	3.0	%
Minimum attenuation	30	36	—	dB
	30	35	—	dB
	30	35	—	dB
	30	36	—	dB
	30	36	—	dB
	30	40	—	dB
Channel 1-10	35	40	—	dB
Channel 11	25 ⁴⁾	43 ⁴⁾	—	dB
	48	54	—	dB
	25	33	—	dB
	20	25	—	dB
	25	30	—	dB
	26	30	—	dB
	22	26	—	dB
	29	32	—	dB

1) See Sec. Matching circuit (p. 5).
 2) Over temperature range +25°C to +85°C.
 3) Error Vector Magnitude (EVM) based on definition given in 3GPP TS 25.141.
 4) Average attenuation in WLAN channel 11 by integration over 18MHz from 2453 MHz to 2471 MHz.

Data sheet

6.3 TX – RX

Temperature range for specification	T_{SPEC}	= -10 °C ... +85 °C
TX terminating impedance	Z_{TX}	= 50 Ω with par. 4.7 nH ¹⁾
ANT terminating impedance	Z_{ANT}	= 50 Ω with par. 2.2 nH ¹⁾
RX terminating impedance	Z_{RX}	= 50 Ω with par. 4.3 nH ¹⁾

Characteristics TX – RX			min. for T_{SPEC}	typ. @+25 °C	max. for T_{SPEC}	
Minimum isolation	α_{min}	2500... 2570 MHz	38	43	—	dB
		2570... 2620 MHz	15	20	—	dB
		2620... 2690 MHz	48	58	—	dB

¹⁾ See Sec. Matching circuit (p. 5).

Data sheet

7 Maximum ratings

Storage temperature	$T_{STG} = -40\text{ °C} \dots +85\text{ °C}$	
DC voltage	$V_{DC} = 0\text{ V (max.)}$	
ESD voltage	$V_{ESD} = 50\text{ V (max.)}^{1)}$	
Input power	P_{IN}	
@ TX port: 2620 ... 2690 MHz	26 dBm	Source and load impedance 50Ω. LTE 5MHz downlink. T=55°C, 100.000hrs. ²⁾
@ TX port: other frequency range(s)	10 dBm	Source and load impedance 50Ω.
Operating lifetime with output power at antenna	P_{OUT}	
@ ANT port: 2620 ... 2690 MHz	22.5 dBm	Continuous wave T= 55 °C, 100.000 hrs. ³⁾

¹⁾ According to JESD22-A115A (machine model), 1 negative and 1 positive pulses.

²⁾ Time to failure (TTF) according to accelerated power durability tests, and wear out models.

³⁾ According to accelerated high temperature operating life (HOTL) test.

Data sheet

8 Transmission coefficients

8.1 TX – ANT

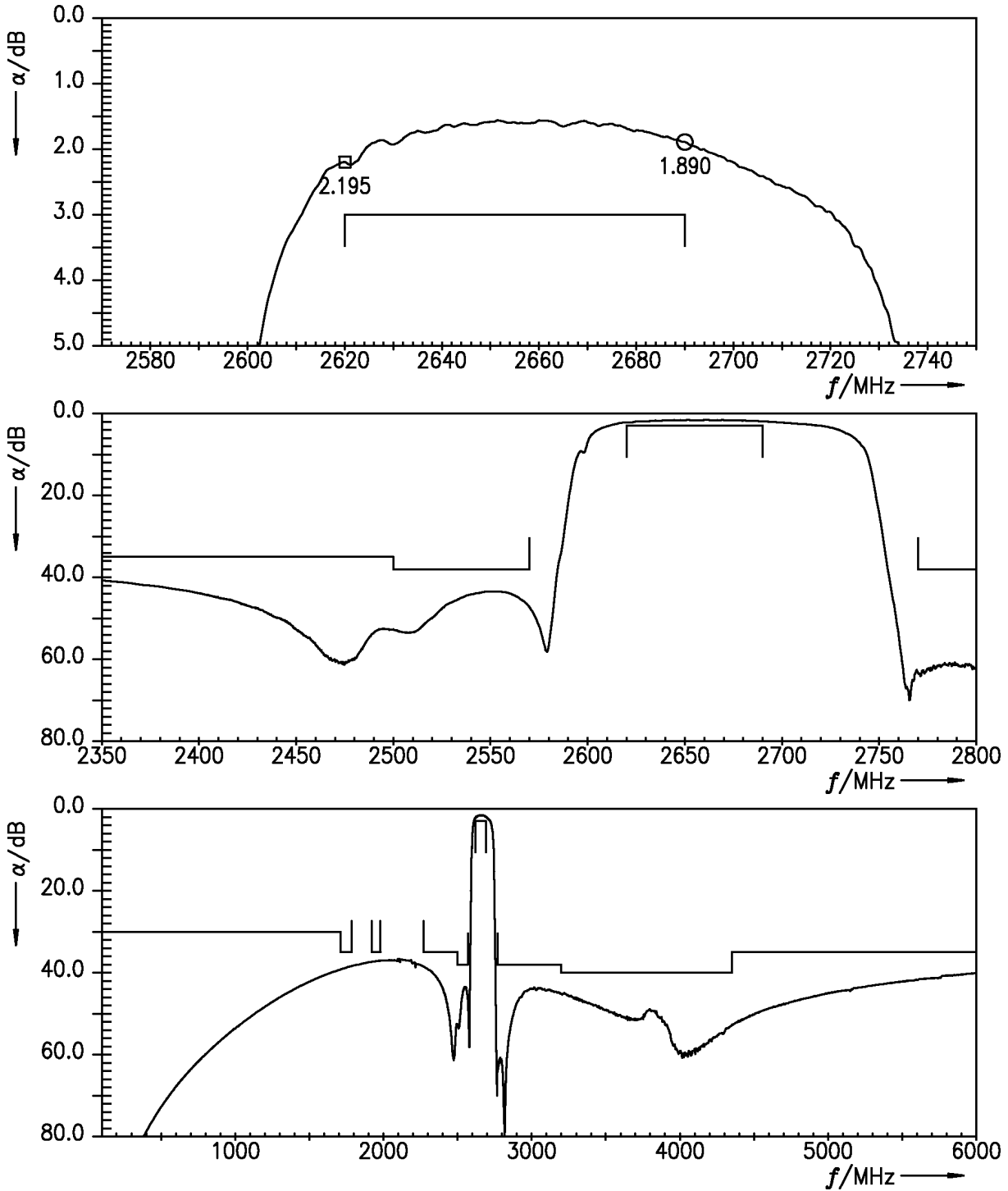

Figure 4: Attenuation TX – ANT.

Data sheet

8.2 ANT – RX

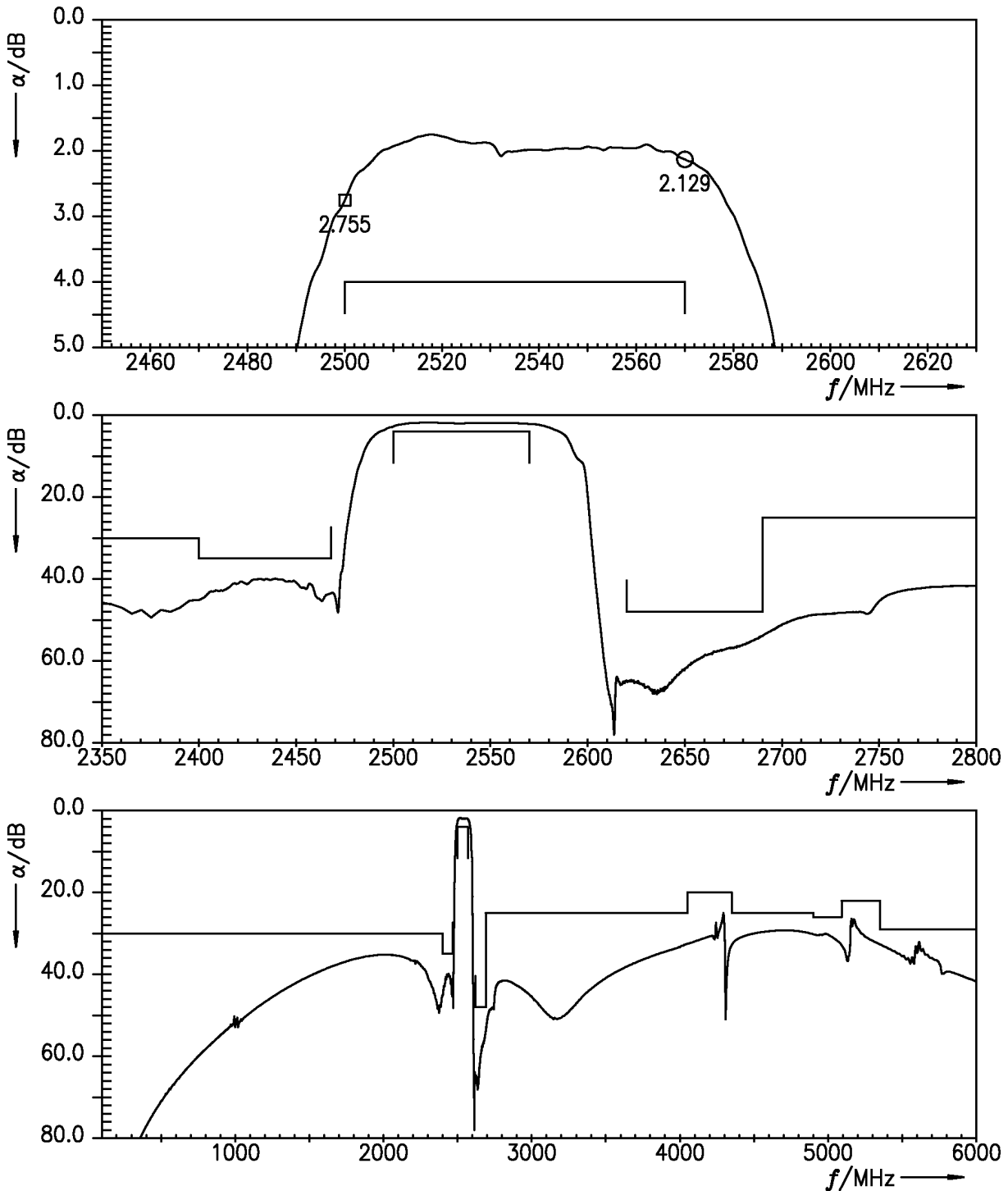

Figure 5: Attenuation ANT – RX.

Data sheet

8.3 TX – RX

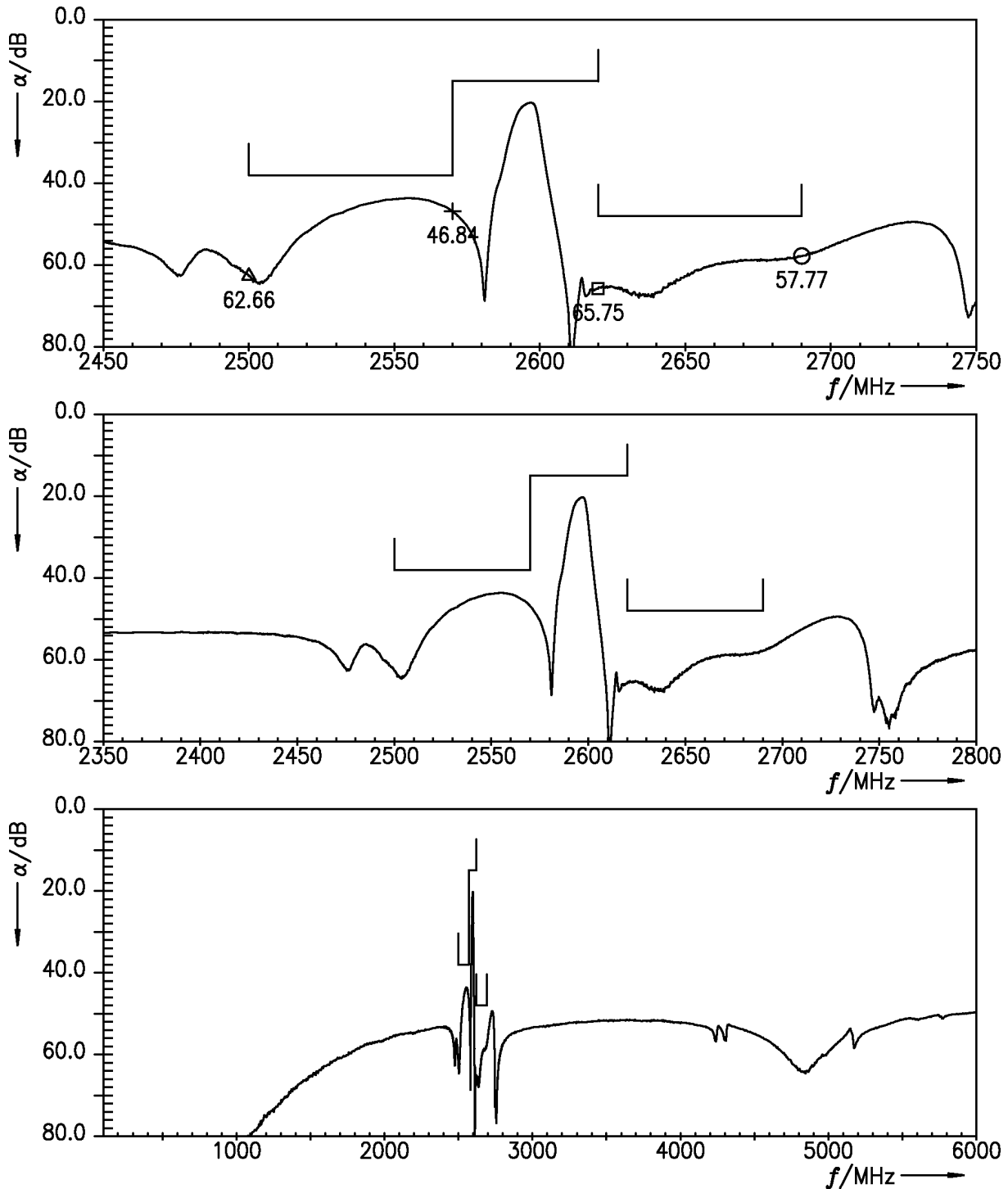

Figure 6: Isolation TX – RX.

Data sheet

9 Reflection coefficients

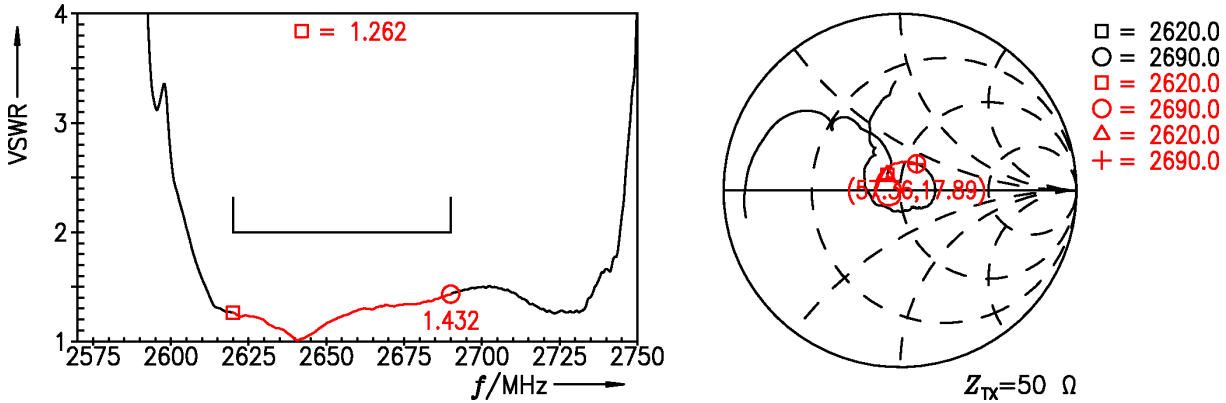

Figure 7: Reflection coefficient at TX port.

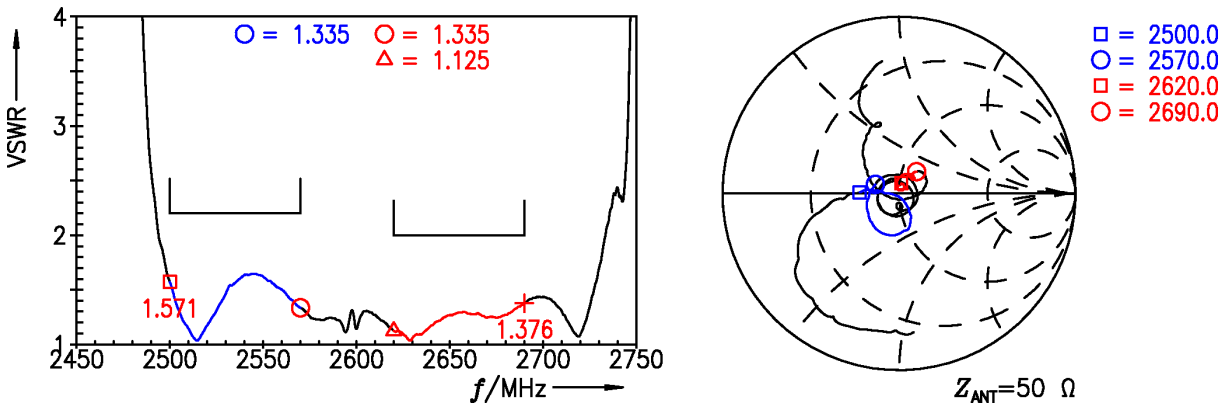

Figure 8: Reflection coefficient at ANT port (TX and RX frequencies).

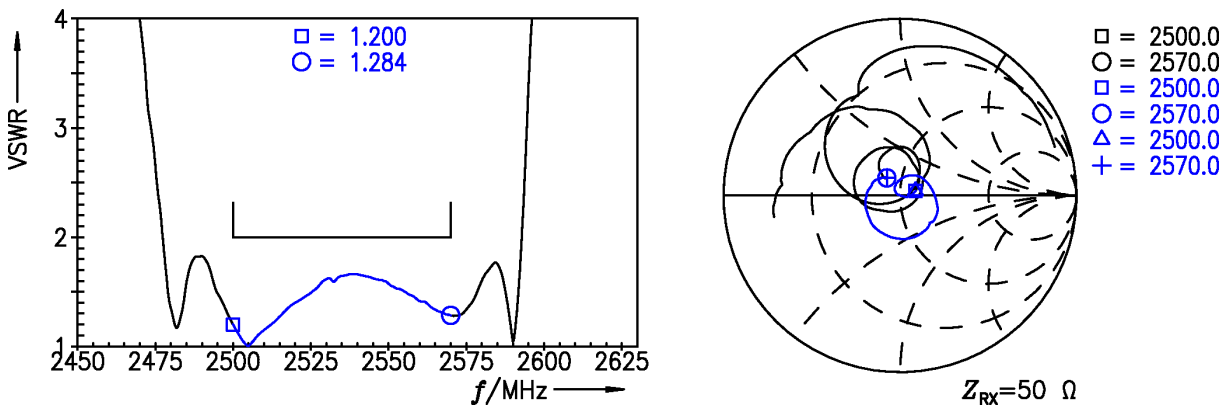

Figure 9: Reflection coefficient at RX port.

Data sheet

10 EVMs

10.1 TX – ANT

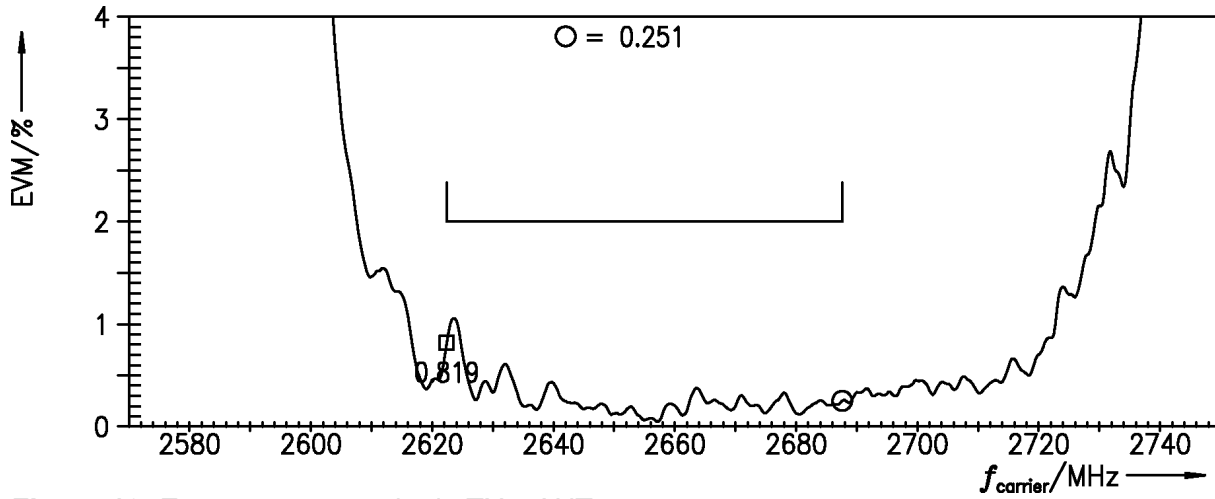

Figure 10: Error vector magnitude TX – ANT.

Data sheet

10.2 ANT – RX

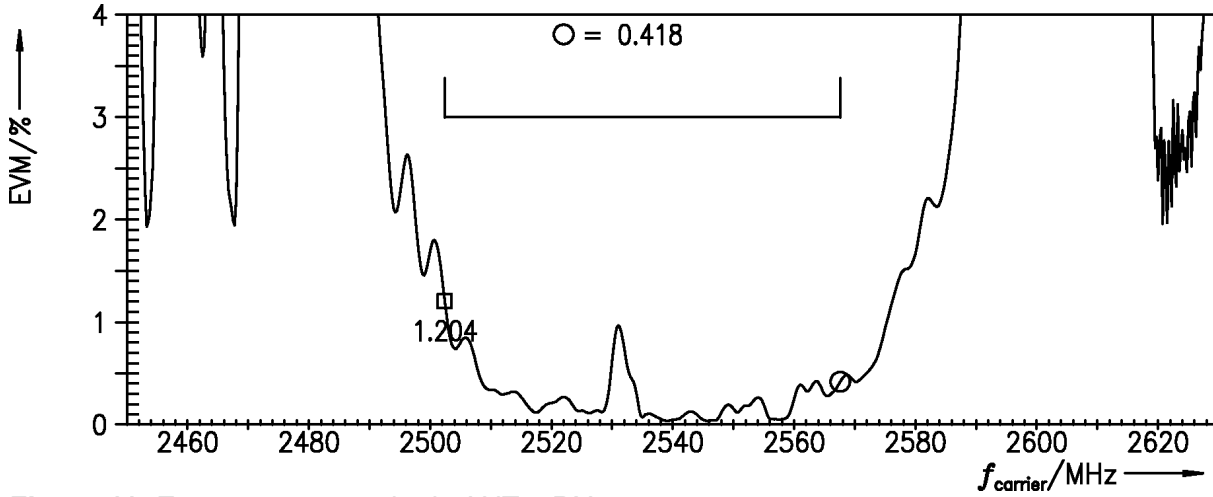

Figure 11: Error vector magnitude ANT – RX.

Data sheet

11 Packing material

11.1 Tape

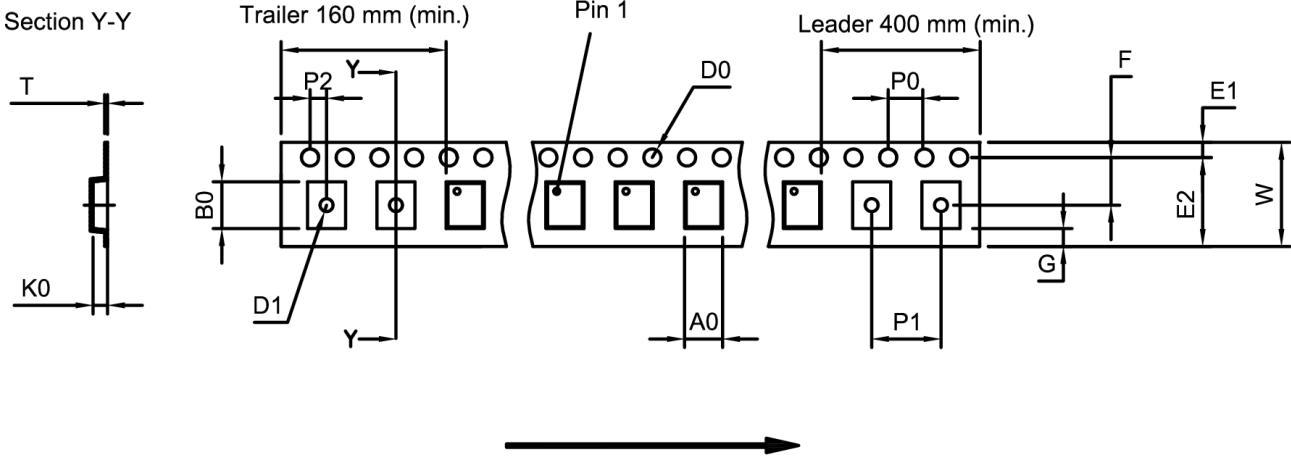

Figure 12: Drawing of tape (first-angle projection) with tape dimensions according to Table 1.

A ₀	2.25±0.05 mm	E ₂	6.25 mm (min.)	P ₁	4.0±0.1 mm
B ₀	2.75±0.05 mm	F	3.5±0.05 mm	P ₂	2.0±0.05 mm
D ₀	1.5+0.1/-0 mm	G	0.75 mm (min.)	T	0.25±0.03 mm
D ₁	1.0 mm (min.)	K ₀	0.6±0.05 mm	W	8.0+0.3/-0.1 mm
E ₁	1.75±0.1 mm	P ₀	4.0±0.1 mm		

Table 1: Tape dimensions.

11.2 Reel with diameter of 180 mm

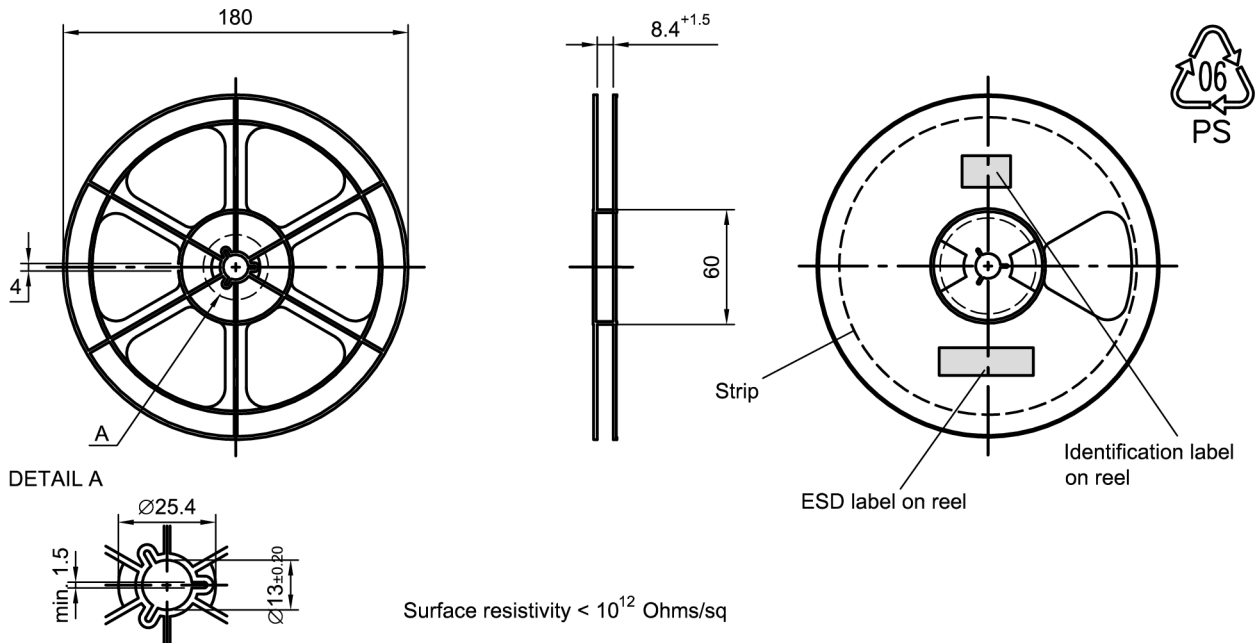

Figure 13: Drawing of reel (first-angle projection) with diameter of 180 mm.

Data sheet

Dimensions [mm]

X = 220+5

Y = 235+5

Sealing area 10±3

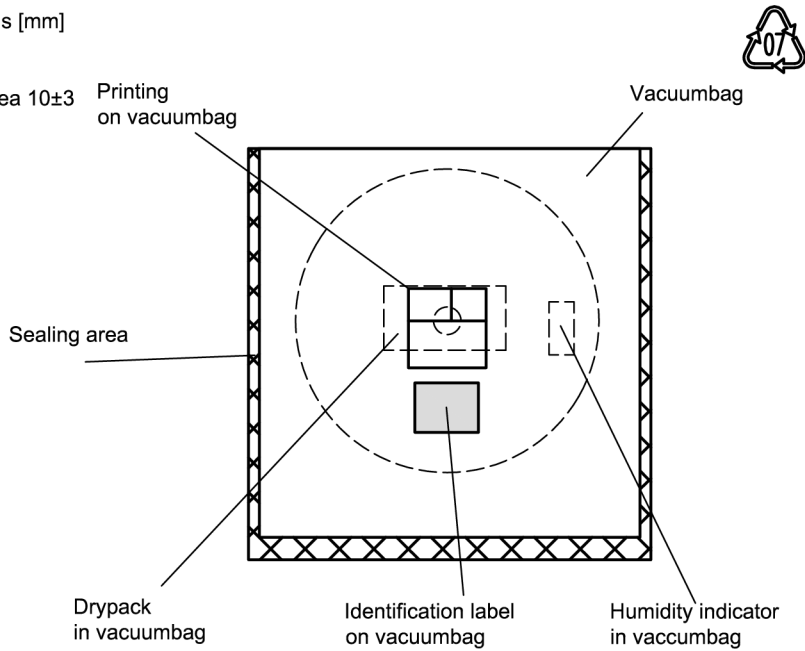

Figure 14: Drawing of moisture barrier bag (MBB) for reel with diameter of 180 mm.

Dimensions [mm]

L = 188

B = 188

H = 30

Tolerance ±5

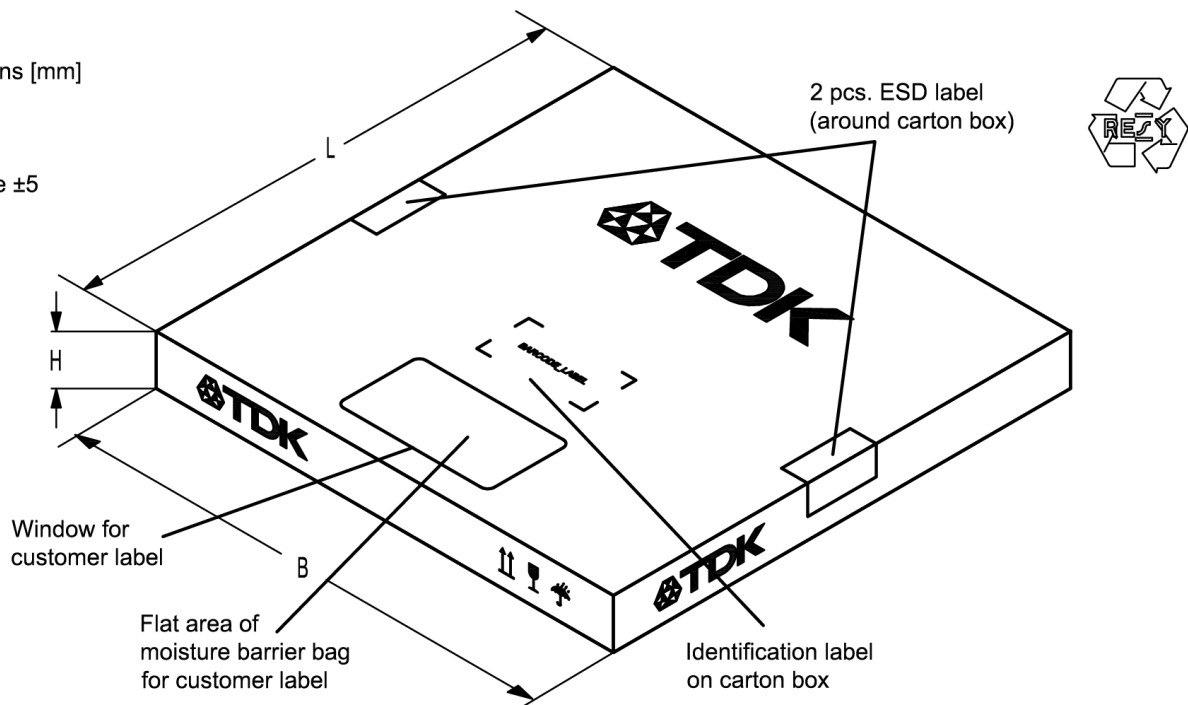

Figure 15: Drawing of folding box for reel with diameter of 180 mm.

Data sheet

11.3 Reel with diameter of 330 mm

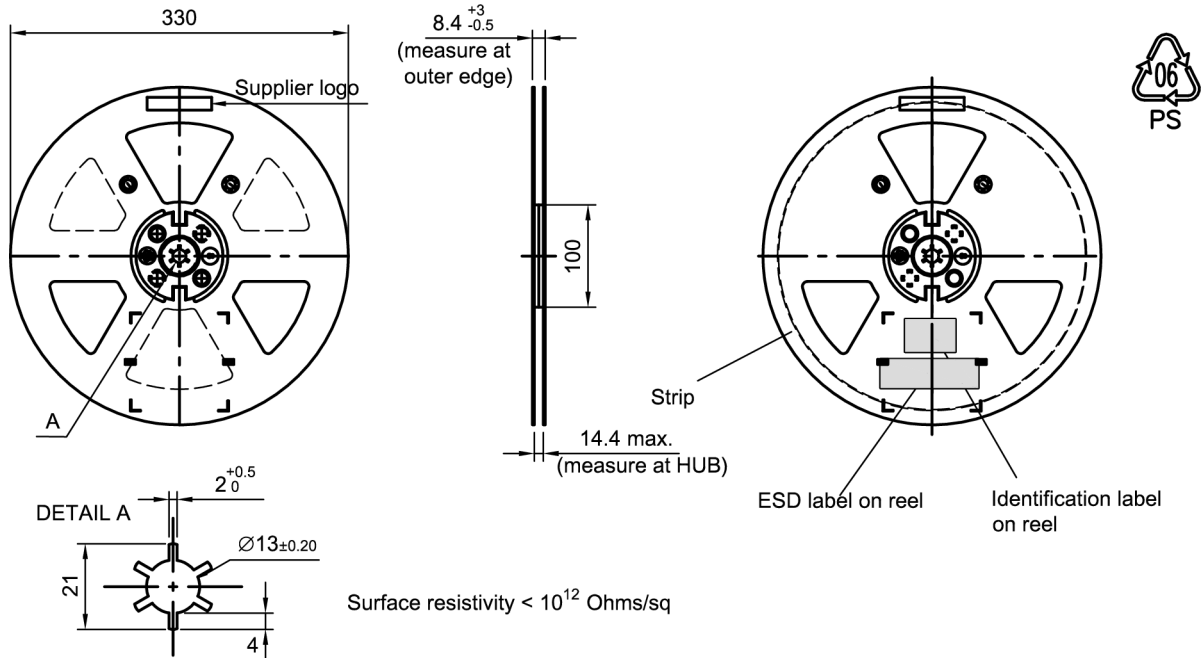

Figure 16: Drawing of reel (first-angle projection) with diameter of 330 mm.

Dimensions [mm]
 X = 400±5
 Y = 418±5
 Sealing area 10±3

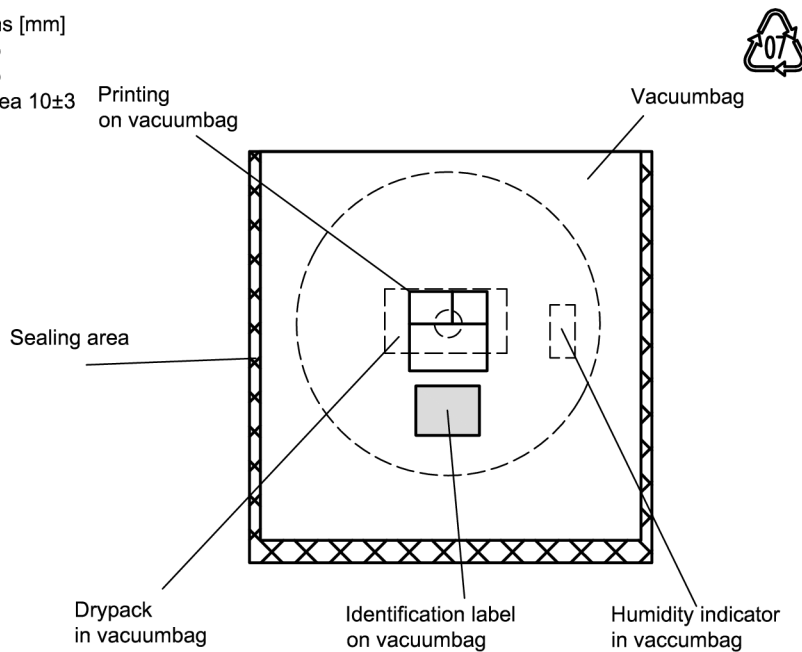

Figure 17: Drawing of moisture barrier bag (MBB) for reel with diameter of 330 mm.

Data sheet

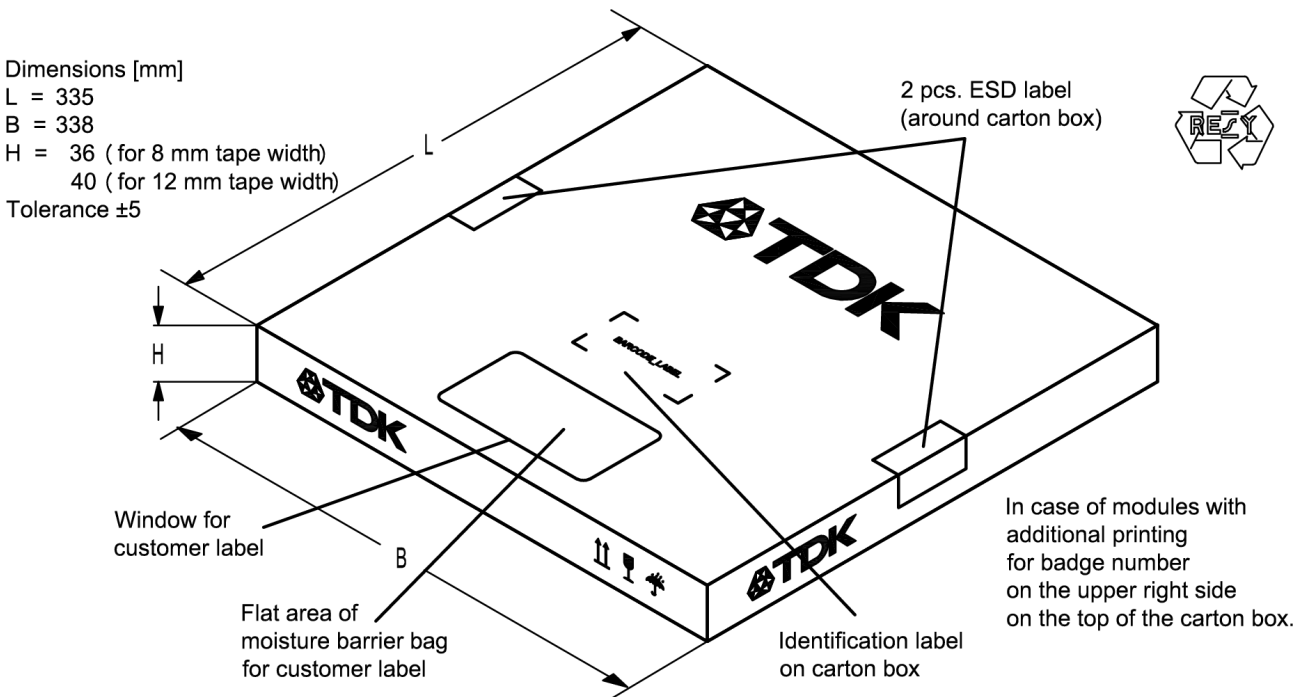

Figure 18: Drawing of folding box for reel with diameter of 330 mm.

12 Marking

Products are marked with product type number and lot number encoded according to Table 2:

■ Type number:

The 4 digit type number of the ordering code, e.g., B3xxxxB**1234**xxxx,
is encoded by a special BASE32 code into a 3 digit marking.

Example of decoding type number marking on device in decimal code.
 $16J \Rightarrow 1234$
 $1 \times 32^2 + 6 \times 32^1 + 18 (=J) \times 32^0 = 1234$

The BASE32 code for product type B8032 is 7V0.

■ Lot number:

The last 5 digits of the lot number, e.g., **12345**,
are encoded based on a special BASE47 code into a 3 digit marking.

Example of decoding lot number marking on device in decimal code.
 $5UY \Rightarrow 12345$
 $5 \times 47^2 + 27 (=U) \times 47^1 + 31 (=Y) \times 47^0 = 12345$

Data sheet

Adopted BASE32 code for type number			
Decimal value	Base32 code	Decimal value	Base32 code
0	0	16	G
1	1	17	H
2	2	18	J
3	3	19	K
4	4	20	M
5	5	21	N
6	6	22	P
7	7	23	Q
8	8	24	R
9	9	25	S
10	A	26	T
11	B	27	V
12	C	28	W
13	D	29	X
14	E	30	Y
15	F	31	Z

Adopted BASE47 code for lot number			
Decimal value	Base47 code	Decimal value	Base47 code
0	0	24	R
1	1	25	S
2	2	26	T
3	3	27	U
4	4	28	V
5	5	29	W
6	6	30	X
7	7	31	Y
8	8	32	Z
9	9	33	b
10	A	34	d
11	B	35	f
12	C	36	h
13	D	37	n
14	E	38	r
15	F	39	t
16	G	40	v
17	H	41	\
18	J	42	?
19	K	43	{
20	L	44	}
21	M	45	<
22	N	46	>
23	P		

Table 2: Lists for encoding and decoding of marking.

Data sheet

13 Soldering profile

The recommended soldering process is in accordance with IEC 60068-2-58 – 3rd edit and IPC/JEDEC J-STD-020B.

ramp rate	≤ 3 K/s
preheat	125 °C to 220 °C, 150 s to 210 s, 0.4 K/s to 1.0 K/s
$T > 220\text{ °C}$	30 s to 70 s
$T > 230\text{ °C}$	min. 10 s
$T > 245\text{ °C}$	max. 20 s
$T \geq 255\text{ °C}$	–
peak temperature T_{peak}	250 °C +0/-5 °C
wetting temperature T_{min}	230 °C +5/-0 °C for 10 s ± 1 s
cooling rate	≤ 3 K/s
soldering temperature T	measured at solder pads

Table 3: Characteristics of recommended soldering profile for lead-free solder (Sn95.5Ag3.8Cu0.7).

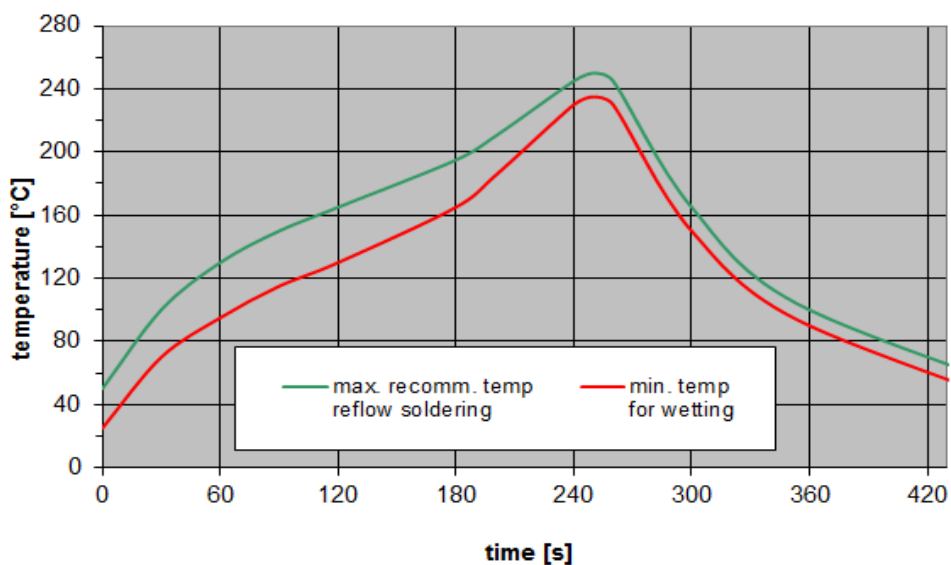

Figure 19: Recommended reflow profile for convection and infrared soldering – lead-free solder.

SAW components	B8032
BAW/SAW duplexer for small cell	2535/ 2655 MHz

Data sheet

14 Annotations

14.1 Matching coils

See TDK inductor pdf-catalog <http://www.tdk.co.jp/tefe02/coil.htm#aname1> and Data Library for circuit simulation <http://www.tdk.co.jp/etvcl/index.htm>.

14.2 RoHS compatibility

ROHS-compatible means that products are compatible with the requirements according to Art. 4 (substance restrictions) of Directive 2011/65/EU of the European Parliament and of the Council of June 8th, 2011, on the restriction of the use of certain hazardous substances in electrical and electronic equipment ("Directive") with due regard to the application of exemptions as per Annex III of the Directive in certain cases.

14.3 Scattering parameters (S-parameters)

The pin/port assignment is available in the headers of the S-parameter files. Please contact your local EPCOS sales office.

14.4 Ordering codes and packing units

Ordering code	Packing unit
B39262B8032P810	5000 pcs

Table 4: Ordering codes and packing units.

Data sheet

15 Cautions and warnings

15.1 Display of ordering codes for EPCOS products

The ordering code for one and the same product can be represented differently in data sheets, data books, other publications and the website of EPCOS, or in order-related documents such as shipping notes, order confirmations and product labels. The varying representations of the ordering codes are due to different processes employed and do not affect the specifications of the respective products. Detailed information can be found on the Internet under www.epcos.com/orderingcodes.

15.2 Material information

Due to technical requirements components may contain dangerous substances. For information on the type in question please also contact one of our sales offices.

15.3 Moldability

Before using in overmolding environment, please contact your local EPCOS sales office.

15.4 Package information

Landing area

The printed circuit board (PCB) land pattern (landing area) shown is based on EPCOS internal development and empirical data and illustrated for example purposes, only. As customers' SMD assembly processes may have a plenty of variants and influence factors which are not under control or knowledge of EPCOS, additional careful process development on customer side is necessary and strongly recommended in order to achieve best soldering results tailored to the particular customer needs.

Dimensions

Unless otherwise specified all dimensions are understood using unit millimeter (mm).

Dimensions do not include burrs.

Projection method

Unless otherwise specified first-angle projection is applied.

Important notes

The following applies to all products named in this publication:

1. Some parts of this publication contain **statements about the suitability of our products for certain areas of application**. These statements are based on our knowledge of typical requirements that are often placed on our products in the areas of application concerned. We nevertheless expressly point out **that such statements cannot be regarded as binding statements about the suitability of our products for a particular customer application**. As a rule, EPCOS is either unfamiliar with individual customer applications or less familiar with them than the customers themselves. For these reasons, it is always ultimately incumbent on the customer to check and decide whether an EPCOS product with the properties described in the product specification is suitable for use in a particular customer application.
2. We also point out that **in individual cases, a malfunction of electronic components or failure before the end of their usual service life cannot be completely ruled out in the current state of the art, even if they are operated as specified**. In customer applications requiring a very high level of operational safety and especially in customer applications in which the malfunction or failure of an electronic component could endanger human life or health (e.g. in accident prevention or life-saving systems), it must therefore be ensured by means of suitable design of the customer application or other action taken by the customer (e.g. installation of protective circuitry or redundancy) that no injury or damage is sustained by third parties in the event of malfunction or failure of an electronic component.
3. **The warnings, cautions and product-specific notes must be observed.**
4. In order to satisfy certain technical requirements, **some of the products described in this publication may contain substances subject to restrictions in certain jurisdictions (e.g. because they are classed as hazardous)**. Useful information on this will be found in our Material Data Sheets on the Internet (www.epcos.com/material). Should you have any more detailed questions, please contact our sales offices.
5. We constantly strive to improve our products. Consequently, **the products described in this publication may change from time to time**. The same is true of the corresponding product specifications. Please check therefore to what extent product descriptions and specifications contained in this publication are still applicable before or when you place an order. We also **reserve the right to discontinue production and delivery of products**. Consequently, we cannot guarantee that all products named in this publication will always be available.
The aforementioned does not apply in the case of individual agreements deviating from the foregoing for customer-specific products.
6. Unless otherwise agreed in individual contracts, **all orders are subject to the current version of the “General Terms of Delivery for Products and Services in the Electrical Industry” published by the German Electrical and Electronics Industry Association (ZVEI)**.
7. The trade names EPCOS, Alu-X, CeraDiode, CeraLink, CeraPad, CeraPlas, CSMP, CSSP, CTVS, DeltaCap, DigiSiMic, DSSP, ExoCore, FilterCap, FormFit, LeaXield, MiniBlue, MiniCell, MKD, MKK, MotorCap, PCC, PhaseCap, PhaseCube, PhaseMod, PhiCap, PQSine, SIFERRIT, SIFI, SIKOREL, SilverCap, SIMDAD, SiMic, SIMID, SineFormer, SIOV, SIP5D, SIP5K, TFAP, ThermoFuse, WindCap are **trademarks registered or pending** in Europe and in other countries. Further information will be found on the Internet at www.epcos.com/trademarks.