

DESIGNED AND DIMENSIONED IN MILLIMETERS [INCHES]

ERM5-XXX-XX.X-X-DV-XX-TR

DO NOT SCALE FROM THIS PRINT

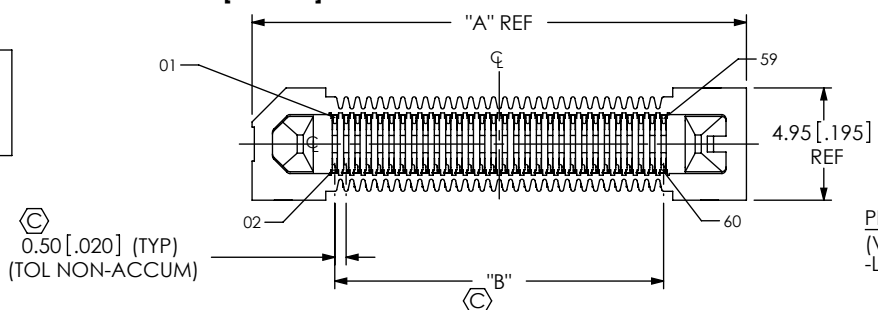

No OF POSITIONS (PER ROW)
 -005, -010, -020,
 -030, -040, -050,
 -060, -070, -075

LEAD STYLE
 -02.0 = 2MM
 -04.0 = 4MM
 -05.0 = 5MM

PLATING SPECIFICATION
 (VALUES GIVEN ARE IN MICRO-INCHES)
 -L: LIGHT SELECTIVE,
 10 Au / 50 Ni MIN ON CONTACT,
 MATTE TIN TAIL
 -S: SELECTIVE, 30 Au / 50 Ni MIN ON CONTACT,
 MATTE TIN TAIL

PACKAGING
 -TR: TAPE & REEL
 (SEE NOTE 5)

OPTIONS
 -K: POLYIMIDE FILM PAD
 -FL: FRICTION LOCK (NOT AVAILABLE WITH -WT, ONLY AVAILABLE UP TO 30 POSITIONS)
 (FOR MATING WITH ERF5-XXX-XX.X-X-DV-FL)
 -WT: WELD TAB (NOT AVAILABLE WITH -FL)
 (FOR MATING WITH ERF5-XXX-XX.X-X-DV-WT)

ROW SPECIFICATION
 -DV: DOUBLE VERTICAL

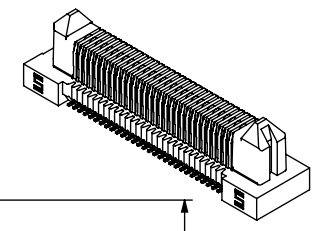
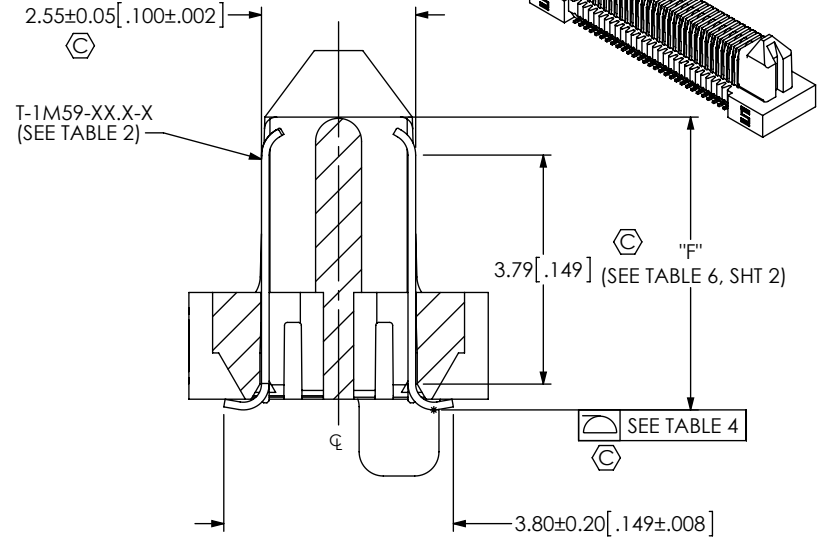
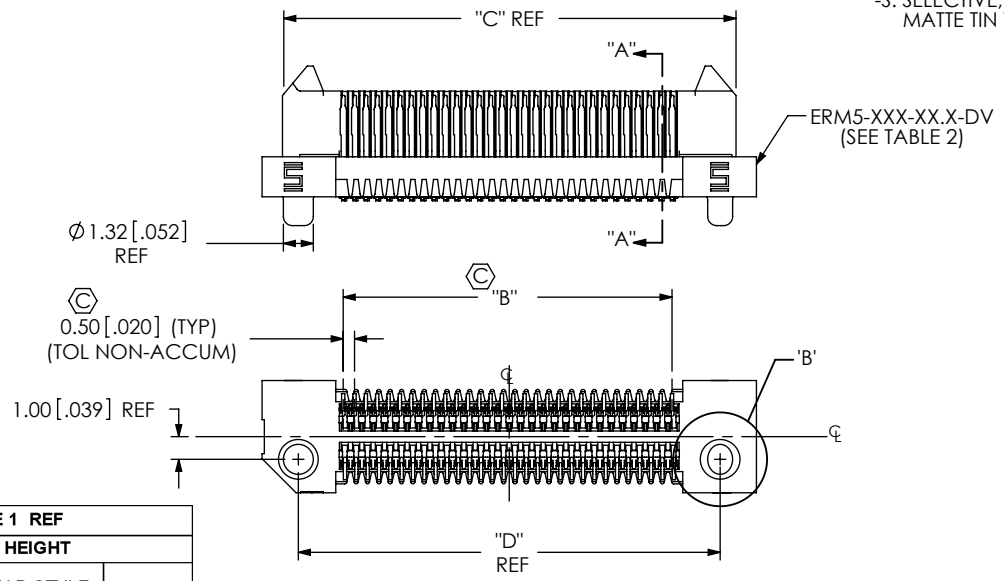

TABLE 1 REF

STACK HEIGHT

ERM5 LEAD STYLE	ERF5 LEAD STYLE	
-02.0	-05.0	-07.0
-05.0	7.0MM	9MM
-04.0	10.0MM	12MM
-04.0	9.0MM	11MM

FIG 1
 ERM5-030-02.0-X-DV-XX SHOWN

TABLE 2

LEAD STYLE	ERM5-XXX-XX.X-DV	T-1M59-XX.X-X
-02.0	ERM5-XXX-02.0-DV	T-1M59-02.0-X
-05.0	ERM5-XXX-05.0-DV	T-1M59-05.0-X
-04.0	ERM5-XXX-04.0-DV	T-1M59-04.0-X

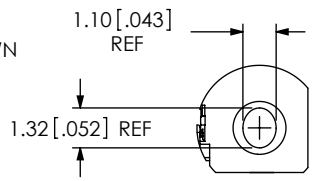

DETAIL 'B'
 SCALE 4:1

- NOTES:
- ⊕ REPRESENTS A CRITICAL DIMENSION.
 - BURR ALLOWANCE: 0.038 [.0015] MAX.
 - MINIMUM PUSHOUT FORCE: 1.6 N [.4 LB.]
 MINIMUM WELD TAB PUSHOUT FORCE:
 -04.0 & -05.0 LEAD STYLES: 2.25 N [.5 LB.]
 -02.0 LEAD STYLE: 1.45 N [.3 LB.]
 - DELETED
 - FOR QUANTITIES UP TO 49 PIECES, NO LEADER, TRAILER, OR REEL WILL BE SUPPLIED. FOR QUANTITIES 50-124, NO LEADER OR TRAILER WILL BE SUPPLIED.

TABLE 3

POSITION	"A"	"B"	"C"	"D"
-005	9.30 [0.366]	2.00 [0.079]	7.50 [0.295]	6.10 [0.240]
-010	11.80 [0.465]	4.50 [0.177]	10.00 [0.394]	8.60 [0.339]
-020	16.80 [0.661]	9.50 [0.374]	15.00 [0.591]	13.60 [0.535]
-030	21.80 [0.858]	14.50 [0.571]	20.00 [0.787]	18.60 [0.732]
-040	26.80 [1.055]	19.50 [0.768]	25.00 [0.984]	23.60 [0.929]
-050	31.80 [1.252]	24.50 [0.965]	30.00 [1.181]	28.60 [1.126]
-060	36.80 [1.449]	29.50 [1.161]	35.00 [1.378]	33.60 [1.323]
-070	41.80 [1.646]	34.50 [1.358]	40.00 [1.575]	38.60 [1.520]
-075	44.30 [1.744]	37.00 [1.457]	42.50 [1.673]	41.10 [1.618]

TABLE 4

No. OF POS.	⊕
-010, -020, -030, -040	0.10 [.004]
-050, -060, -070, 075	0.13 [.005]

UNLESS OTHERWISE SPECIFIED, DIMENSIONS ARE IN MILLIMETERS [INCHES].
 TOLERANCES ARE:
 DECIMALS ANGLES
 X.X: ±0.3 [.01] 2°
 X.XX: ±0.13 [.005]
 X.XXX: ±0.050 [.0020]

PROPRIETARY NOTE
 THIS DOCUMENT CONTAINS INFORMATION CONFIDENTIAL AND PROPRIETARY TO SAMTEC, INC. AND SHALL NOT BE REPRODUCED OR TRANSFERRED TO OTHER DOCUMENTS OR DISCLOSED TO OTHERS OR USED FOR ANY PURPOSE OTHER THAN THAT WHICH IT WAS OBTAINED WITHOUT THE EXPRESSED WRITTEN CONSENT OF SAMTEC, INC.

520 PARK EAST BLVD, NEW ALBANY, IN 47150
 PHONE: 812-944-6733 FAX: 812-948-5047
 e-Mail: info@SAMTEC.com code 55322

MATERIAL: DO NOT SCALE DRAWING
 INSULATOR: LCP, COLOR: BLACK
 TERMINAL: BeCu OR PHOS BRONZE

SHEET SCALE: 3:1

DESCRIPTION:
 .5MM EDGE RATE TERMINAL ASSEMBLY

DWG. NO.
ERM5-XXX-XX.X-X-DV-XX

BY: DAVID W 4/30/2008 SHEET 1 OF 2

IN PROCESS 1
CUT T-1M59-XX.X-X TERMINAL COMBS
(ALL TAILS SAME DIRECTION)

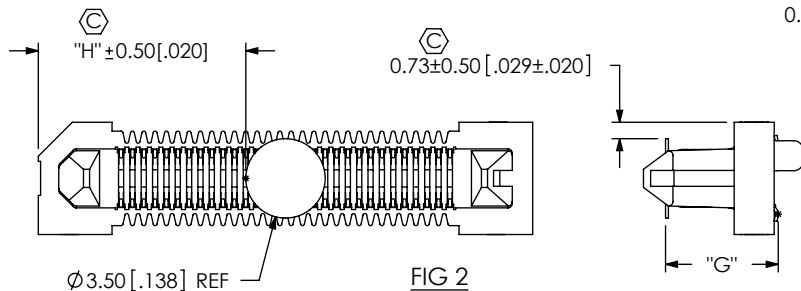
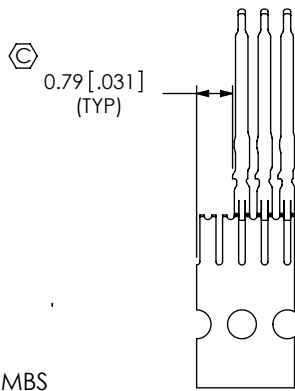
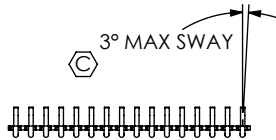

FIG 2
-K OPTION
(USE K-DOT-138-250-005)
(ERM5-030-02.0-X-DV-K SHOWN)

LEAD STYLE	"E"	"F"	"G"	"M"
-02.0	1.94 [0.076]	4.84 [0.191]	4.97 [0.196]	1.35 [0.053]
-05.0	4.94 [0.194]	7.84 [0.309]	7.97 [0.314]	1.40 [0.055]
-04.0	3.94 [0.155]	6.84 [0.269]	6.97 [0.274]	1.12 [0.044]

POSITION	"H"			
	-K	-K-WT	-K-FL	
-005	2.90 [0.114]	4.40 [0.173]	4.40 [0.173]	
-010	4.15 [0.163]	5.65 [0.222]	5.65 [0.222]	
-020	6.65 [0.262]	8.15 [0.320]	8.15 [0.320]	
-030	9.15 [0.360]	10.65 [0.419]	10.65 [0.419]	
-040	11.65 [0.459]	13.15 [0.517]		
-050	14.15 [0.557]	15.65 [0.616]		
-060	16.65 [0.656]	18.15 [0.714]		
-070	19.15 [0.754]	20.65 [0.812]		
-075	20.40 [0.803]	21.90 [0.862]		

LEAD STYLE	ERM5-XXX-XX.X-DV-XX	WT-36-XX-T
-02.0	ERM5-XXX-02.0-DV-FL	WT-36-05-T
-05.0	ERM5-XXX-05.0-DV-FL	WT-36-01-T
-04.0	ERM5-XXX-04.0-DV-FL	WT-36-06-T

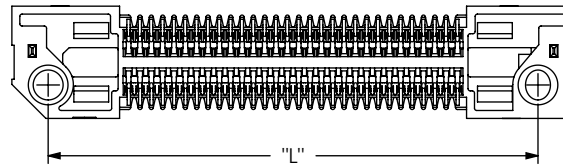
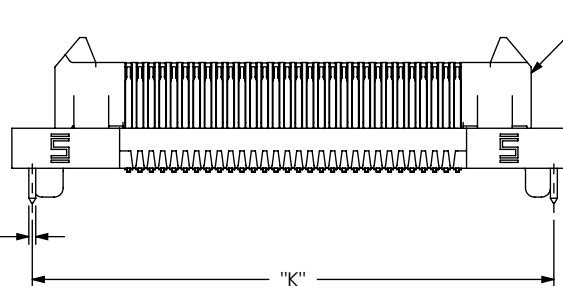
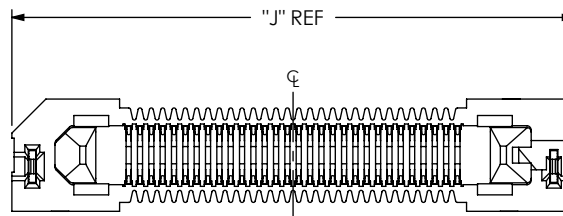

FIG 3
(ERM5-030-02.0-X-DV-FL SHOWN)
(SAME AS FIG 1 EXCEPT AS SHOWN)
(NOT AVAILABLE WITH -WT, ONLY AVAILABLE UP TO 30 POSITIONS)

POSITION	"J"	"K"	"L"
-005	12.30 [0.484]	10.50 [0.413]	9.10 [0.358]
-010	14.80 [0.583]	13.00 [0.512]	11.60 [0.457]
-020	19.80 [0.780]	18.00 [0.709]	16.60 [0.654]
-030	24.80 [0.976]	23.00 [0.906]	21.60 [0.850]
-040	29.80 [1.173]	28.00 [1.102]	26.60 [1.047]
-050	34.80 [1.370]	33.00 [1.299]	31.60 [1.244]
-060	39.80 [1.567]	38.00 [1.496]	36.60 [1.441]
-070	44.80 [1.764]	43.00 [1.693]	41.60 [1.638]
-075	47.30 [1.862]	45.50 [1.791]	44.10 [1.736]

ERM5-XXX-XX.X-DV-FL
(SEE TABLE 8)

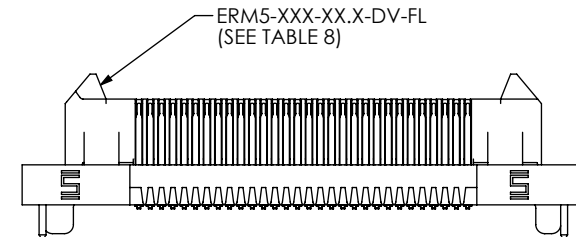
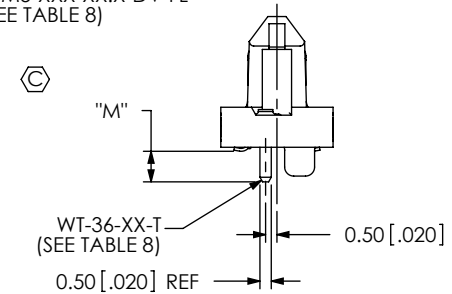

FIG 4
(ERM5-030-02.0-X-DV-WT SHOWN)
(SAME AS FIG 3)
(NOT AVAILABLE WITH -FL)

F:\DWG\MISC\MKTG\ERM5-XXX-XX.X-X-DV-XX-MKT.SLDDRW

PROPRIETARY NOTE

THIS DOCUMENT CONTAINS INFORMATION CONFIDENTIAL AND PROPRIETARY TO SAMTEC, INC. AND SHALL NOT BE REPRODUCED OR TRANSFERRED TO OTHER DOCUMENTS OR DISCLOSED TO OTHERS OR USED FOR ANY PURPOSE OTHER THAN THAT WHICH IT WAS OBTAINED WITHOUT THE EXPRESSED WRITTEN CONSENT OF SAMTEC, INC.

DO NOT SCALE DRAWING

SHEET SCALE: 3:1



520 PARK EAST BLVD, NEW ALBANY, IN 47150
PHONE: 812-944-6733 FAX: 812-948-5047
e-Mail: info@SAMTEC.com code 55322

DESCRIPTION:
.5MM EDGE RATE TERMINAL ASSEMBLY

DWG. NO.
ERM5-XXX-XX.X-X-DV-XX

BY: DAVID W 4/30/2008 SHEET 2 OF 2