

DO NOT SCALE FROM THIS PRINT

NOTES:

1.  $\text{⊕}$  REPRESENTS A CRITICAL DIMENSION.
2. PARTS MAY BE CUT TO POSITION.
3. MAXIMUM CUT FLASH: .010[0.25] ON TAIL SIDE, ALL OTHER AREAS AT .015[0.38]. LOOSE CUT FLASH MUST BE REMOVED.
4. MINIMUM PUSHOUT FORCE: 1.0 LB.
5. TERMINALS TO BE SHEARED TO MEET DIMENSION SPECIFICATION.
6. LAYER PACKAGE 2 - 4 POSITIONS AND TUBE 5 - 50 POSITIONS.
7. MAXIMUM BURR ALLOWANCE: .003[0.08].
8. DUE TO THE HIGH AMOUNT OF INSERTION FORCE NEEDED, THE -EC OPTION IS NOT COMPATIBLE WITH AUTO PLACEMENT. SAMTEC RECOMMENDS MANUAL PLACEMENT FOR ALL ASSEMBLIES WITH THE -EC OPTION.
9. MAXIMUM HEIGHT VARIATION BETWEEN ROWS: .005[0.13].

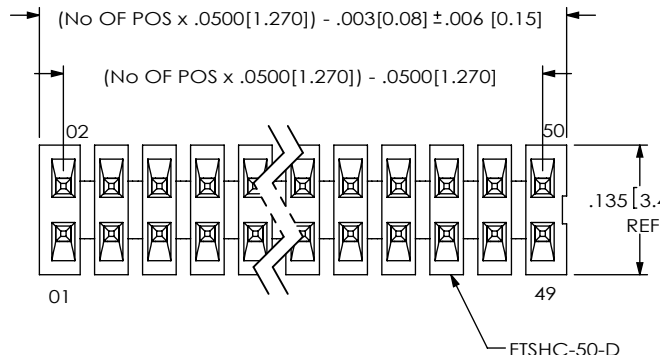

FTSH-1XX-XX-XXX-D-XXX-XX

No OF POSITIONS  
-02 THRU -50  
(PER ROW)

LEAD STYLE  
-01: .120 [3.05]  
-02: .075 [1.91]  
-03: .065 [1.65]  
-04: .150 [3.81]

PLATING SPECIFICATION

- G: 10μ" GOLD IN CONTACT AREA, 3μ" GOLD ON TAIL
- F: 3μ" FLASH SELECTIVE GOLD IN CONTACT AREA, MATTE TIN ON TAIL
- L: 10μ" LIGHT SELECTIVE GOLD IN CONTACT AREA, MATTE TIN ON TAIL
- S: 30μ" SELECTIVE GOLD IN CONTACT AREA, MATTE TIN ON TAIL
- H: 30μ" HEAVY GOLD IN CONTACT AREA, 3μ" GOLD ON TAIL
- FM: 3μ" FLASH SELECTIVE GOLD IN CONTACT AREA, MATTE TIN ON TAIL
- LM: 10μ" LIGHT SELECTIVE GOLD IN CONTACT AREA, MATTE TIN TAIL
- SM: 30μ" HEAVY SELECTIVE GOLD IN CONTACT AREA, MATTE TIN ON TAIL
- LTL: 10μ" LIGHT GOLD IN CONTACT AREA, TIN/LEAD (90%/10 +/-5%) ON TAIL

ROW SPECIFICATION

-D: DOUBLE ROW  
(USE \*\*FTSHC-1XX-XX-XXX-D UNLESS OPTION IS SPECIFIED ABOVE, WHEN OPTION IS SPECIFIED, BUILD PER PRINT USING BODY SPECIFIED FOR REQUIRED OPTION)  
\*\* = SEE FTSHC-1XX-XX-XXX-DX-XX PRINT FOR DETAILS

OPTIONS

- ES: END SHROUDS (SEE FIG 2, SHT 2) (MOLDED 5 POS MIN; -02 & -03 LEAD STYLE ONLY) (MUST USE FTSH-XX-ES-XX-X) (SNAP SHROUDS 9 POS MIN; -02 & -03 LEAD STYLE ONLY) (MUST USE FTSH-50-D)
- EJ: EJECTOR SHROUDS: (SEE FIG 3, SHT 2) (10 POS MIN; -01 LEAD STYLE ONLY) (MUST USE FTSH-50-D)
- EC: LOCKING CLIP (SEE FIG 4, SHT 2; SEE NOTE 8) (9 POS MIN; -02 & -03 LEAD STYLES ONLY) (MUST USE FTSH-50-D)
- EP: GUIDE POST (SEE FIG 5, SHT 2) (9 POS MIN; -02 & -03 LEAD STYLES ONLY) (USE ONLY WHEN MATING WITH CLP) (MUST USE FTSH-50-D)
- EL: BOARD LOCKS (SEE FIG 6, SHT 2) (9 POS MIN; -02 & -03 LEAD STYLES ONLY) (USE ONLY WHEN MATING WITH CLP) (MUST USE FTSH-50-D)
- K: KEYING OPTION FOR MATING WITH FFSD (05 THRU 25 ONLY) (POSITION 13, 17, 20 & 25 AVAILABLE WITH -EJ OPTION) (LEAD STYLE -01 ONLY, SEE FIG 7, SHT 3) (MUST USE FTSH-XX-CN-XX)
- LC: LOCKING CLIP: (SEE FIG 8, SHT 3) (5 POS MIN, ONLY AVAILABLE IN -01 LEAD STYLE) (IN COMBINATION WITH -K, USE FTSH-XX-CN-XX, 10 POSITION MINIMUM, ONLY AVAILABLE IN -01 LEAD STYLE) (MUST USE FTSH-50-D) (SINGLE MATING CYCLE ONLY) (MUST BE MATED TO SAMTEC FFSD SERIES)

POLARIZING OPTION

XXX INDICATES POSITION TO BE OMITTED (NOT AVAILABLE WITH EX OPTIONS) (ONLY AVAILABLE WITH -F, -FM, -L, -LM PLATING OPTIONS)

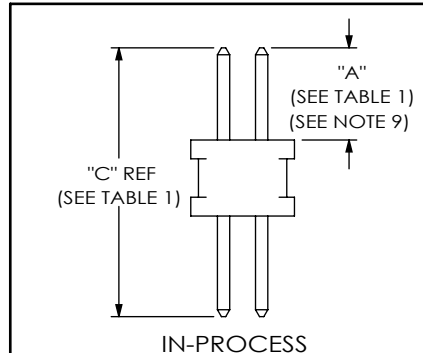
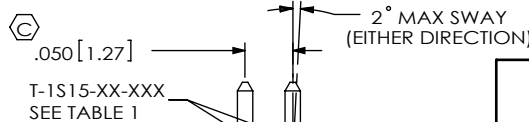
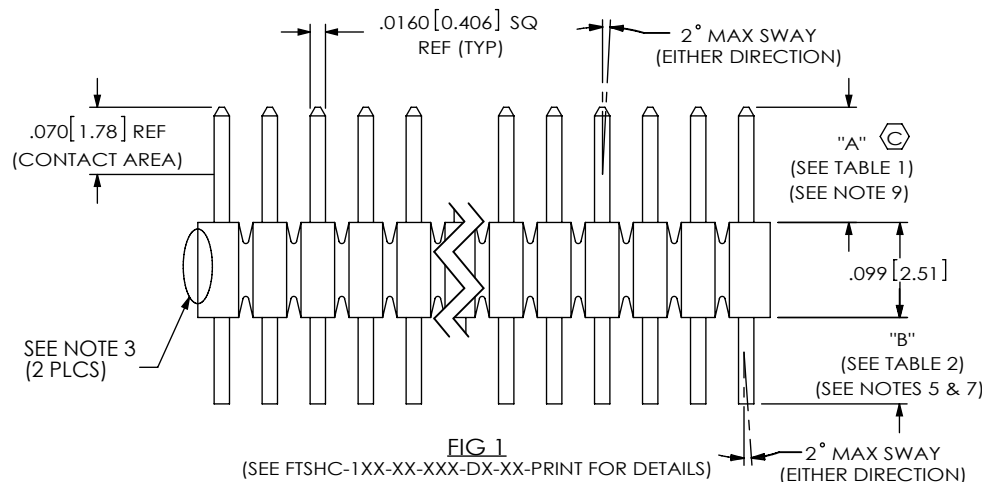

TABLE 2

OPTIONS	"B"
NONE	.09 [2.3]
-ES, -EC	.09 [2.3]
-EJ, -EJ-K	.11 [2.7]
-EP	.09 [2.3]
-EL	.09 [2.3]
-K	.09 [2.3]
-LC, -K-LC	.12 [3.0]

TABLE 1

LEAD STYLE	"A"	TERMINAL	"C" REF
-01	.120 [3.05]	T-1S15-02-XX	.350 [8.89]
-02	.075 [1.91]	T-1S15-02-XX	.350 [8.89]
-03	.065 [1.65]	T-1S15-04-XX	.450 [11.43]
-04	.150 [3.81]	T-1S15-04-XX	.450 [11.43]

UNLESS OTHERWISE SPECIFIED, DIMENSIONS ARE IN INCHES.  
TOLERANCES ARE:  
DECIMALS ANGLES  
.XX: ±.01 [3] 1°  
.XXX: ±.005 [13]  
.XXXX: ±.0010 [25]

MATERIAL: DO NOT SCALE DRAWING SHEET SCALE: 5:1  
INSULATOR: LCD UL 94-V0  
TERMINAL: PHOSPHOR BRONZE

F:\DWG\MISC\MKTG\FTSH-1XX-XX-XXX-D-XXX-XX-MKT.SLDDRW

PROPRIETARY NOTE  
THIS DOCUMENT CONTAINS CONFIDENTIAL AND PROPRIETARY INFORMATION AND ALL DESIGN, MANUFACTURING, REPRODUCTION, USE, PATENT RIGHTS AND SALES RIGHTS ARE EXPRESSLY RESERVED BY SAMTEC, INC. THIS DOCUMENT SHALL NOT BE DISCLOSED, IN WHOLE OR PART, TO ANY UNAUTHORIZED PERSON OR ENTITY NOR REPRODUCED, TRANSFERRED OR INCORPORATED IN ANY OTHER PROJECT IN ANY MANNER WITHOUT THE EXPRESS WRITTEN CONSENT OF SAMTEC, INC.

**samtec**

520 PARK EAST BLVD, NEW ALBANY, IN 47150  
PHONE: 812-944-6733 FAX: 812-948-5047  
e-Mail info@SAMTEC.com code 55322

DESCRIPTION:  
.050 x .050 CL THROUGH HOLE TERMINAL STRIP  
DWG. NO.  
**FTSH-1XX-XX-XXX-D-XXX-XX**  
BY: J. FERRY 02/27/1996 SHEET 1 OF 3

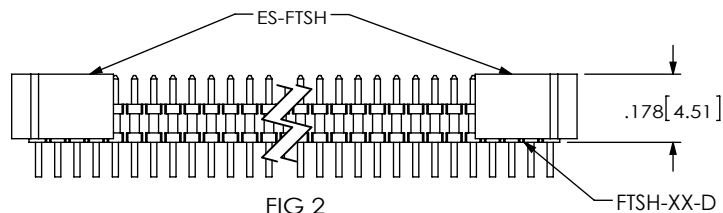
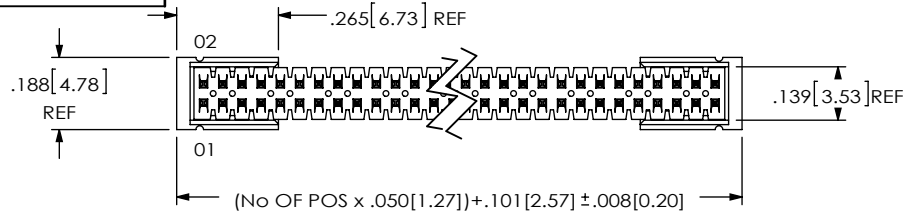

**FIG 2**  
-ES OPTION  
(DIFFERENT AS SHOWN, OTHERWISE SAME AS FIG 1)  
(-02 OR -03 LEAD STYLE ONLY)  
(9 POS MIN FOR SNAP SHROUDS)  
(5 POS MIN FOR MOLDED SHROUDS)

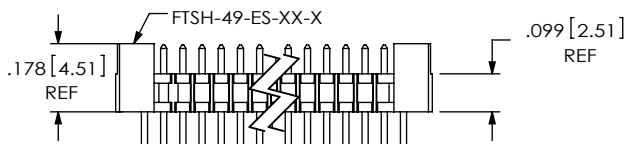
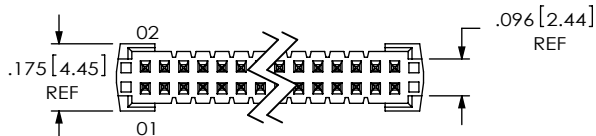

(MOLDED SHROUDS)

**FIG 3**  
-EJ OPTION

(DIFFERENT AS SHOWN, OTHERWISE SAME AS FIG 1)  
(-01 LEAD STYLE ONLY)

USE SUB-FTSH-EJEHA  
(2 REQ'D PER ASSEMBLY  
EACH USES 1 EHA-02,  
1 FTSH-EJ)

POST SIDE OF CONNECTOR

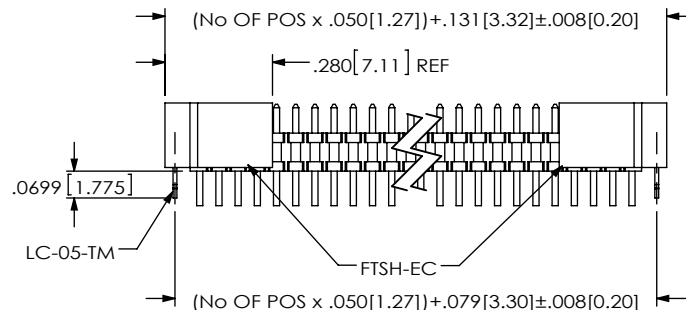
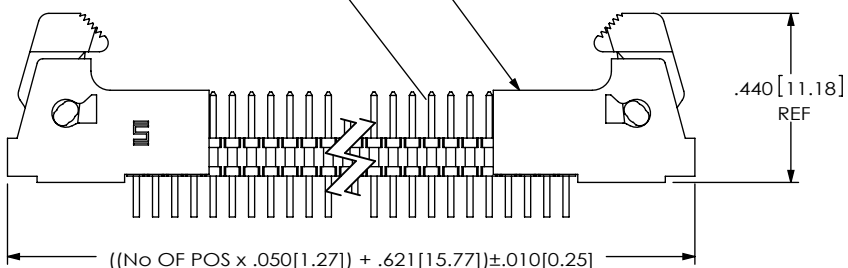

**FIG 4**  
-EC OPTION  
(DIFFERENT AS SHOWN, OTHERWISE SAME AS FIG 2)

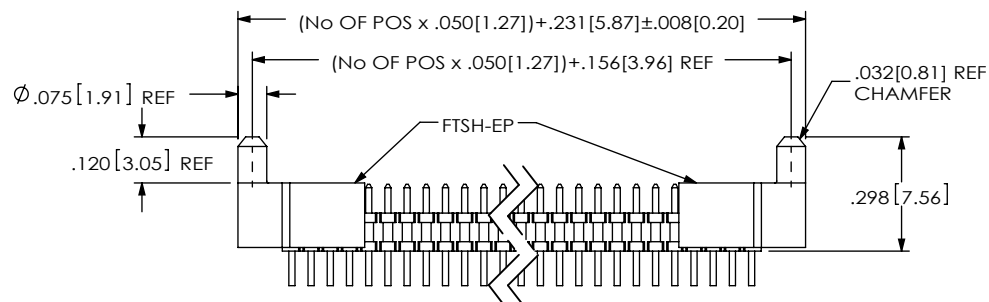

**FIG 5**  
-EP OPTION  
(DIFFERENT AS SHOWN, OTHERWISE SAME AS FIG 2)  
(USE ONLY WHEN MATING WITH CLP)

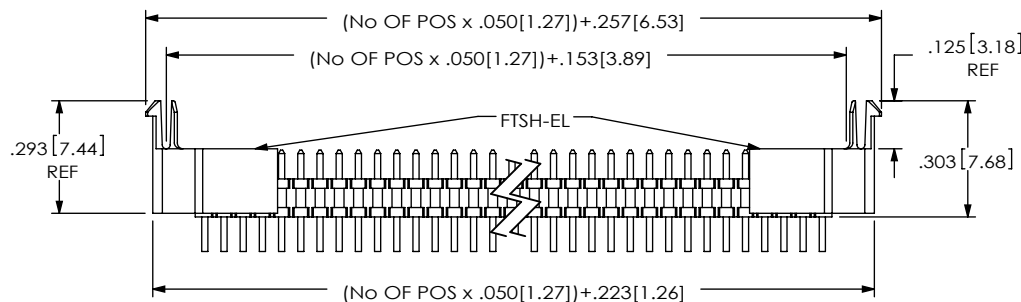

**FIG 6**  
-EL OPTION  
(DIFFERENT AS SHOWN, OTHERWISE SAME AS FIG 2)  
(USE ONLY WHEN MATING WITH CLP)

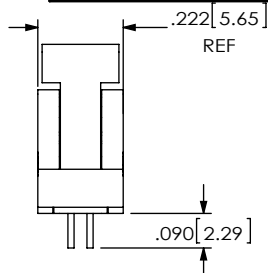

**PROPRIETARY NOTE**  
THIS DOCUMENT CONTAINS CONFIDENTIAL AND PROPRIETARY INFORMATION AND ALL DESIGN, MANUFACTURING, REPRODUCTION, USE, PATENT RIGHTS AND SALES RIGHTS ARE EXPRESSLY RESERVED BY SAMTEC, INC. THIS DOCUMENT SHALL NOT BE DISCLOSED, IN WHOLE OR PART, TO ANY UNAUTHORIZED PERSON OR ENTITY NOR REPRODUCED, TRANSFERRED OR INCORPORATED IN ANY OTHER PROJECT IN ANY MANNER WITHOUT THE EXPRESS WRITTEN CONSENT OF SAMTEC, INC.

DO NOT SCALE DRAWING

SHEET SCALE: 2:1



520 PARK EAST BLVD, NEW ALBANY, IN 47150  
PHONE: 812-944-6733 FAX: 812-948-5047  
e-Mail info@SAMTEC.com code 55322

DESCRIPTION:  
.050 x .050 CL THROUGH HOLE TERMINAL STRIP

DWG. NO.  
**FTSH-1XX-XX-XXX-D-XXX-XX**

BY: J. FERRY 02/27/1996 SHEET 2 OF 3

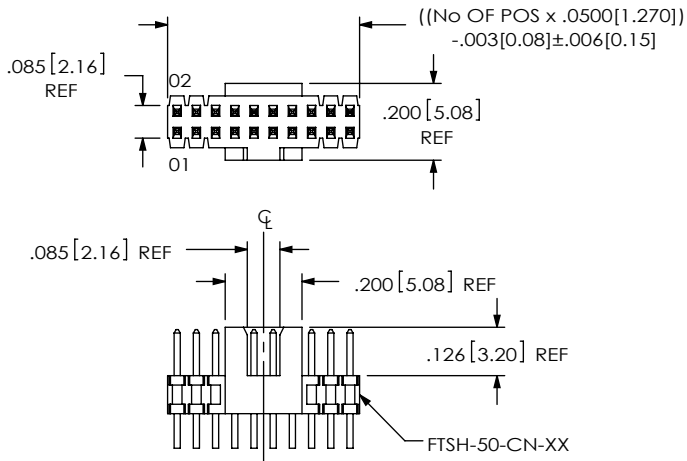

**FIG 7**  
**-K OPTION**  
 (LEAD STYLE -01)  
 (DIFFERENT AS SHOWN, OTHERWISE SAME AS FIG 1)  
 (POSITION 13, 17, 20 & 25 AVAILABLE WITH -K & -EJ OPTION)

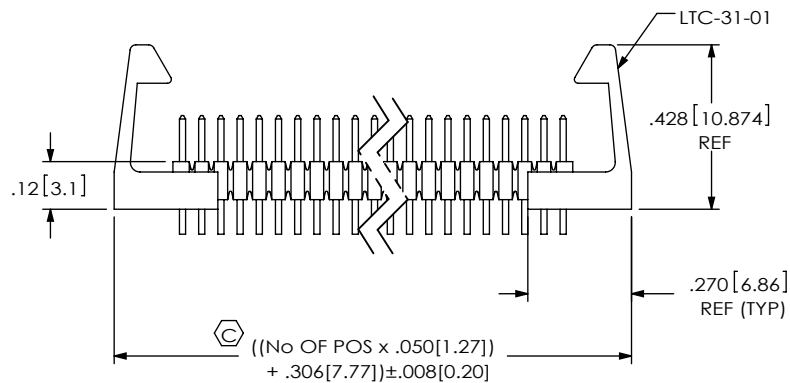

**FIG 8**  
**-LC OPTION**  
 (LEAD STYLE -01)  
 (DIFFERENT AS SHOWN, OTHERWISE SAME AS FIG 1)

**TABLE 3**  
 (SEE NOTE 6)

LEAD STYLE	OPTION(S)	PACKAGING TUBE	TUBE PLUG
-01, -02, -03	NONE	PT-1-24-01-43	TP-24
-04	NONE	PT-1-24-11-09	TP-09
ALL	-EJ, -EJ-K, -LC, -K-LC	PT-1-24-05-09	TP-07
ALL	-EC, -EC-K	PT-1-24-01-38	TP-24
ALL	-EL, -EP, -EL-K, -EP-K	PT-1-24-03-09	TP-09
ALL	-K	PT-1-24-11-09	TP-09
ALL	-ES, -ES-K	PT-1-24-01-55	TP-24

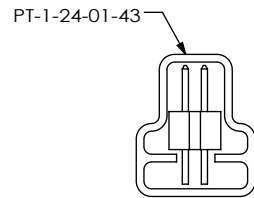

-01, -02, -03

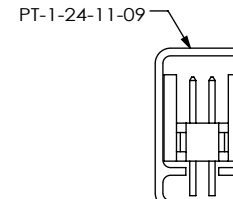

-04 & -K

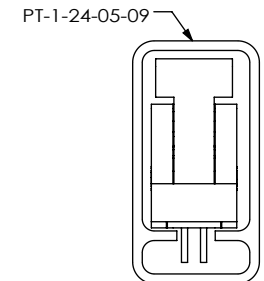

-EJ, -EJ-K, -LC & -LC-K

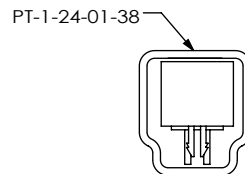

-EC & -EC-K

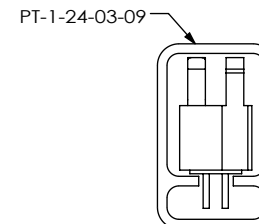

-EL, -EP, -EL-K & -EP-K

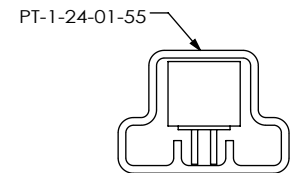

-ES & -ES-K

**FIG 9**  
 TUBE VIEWS

F:\DWG\MISC\MKTG\F\SH-1XX-XX-XXX-D-XXX-XX-MKT.SLDDRW

**PROPRIETARY NOTE**  
 THIS DOCUMENT CONTAINS CONFIDENTIAL AND PROPRIETARY INFORMATION AND ALL DESIGN, MANUFACTURING, REPRODUCTION, USE, PATENT RIGHTS AND SALES RIGHTS ARE EXPRESSLY RESERVED BY SAMTEC, INC. THIS DOCUMENT SHALL NOT BE DISCLOSED, IN WHOLE OR PART, TO ANY UNAUTHORIZED PERSON OR ENTITY NOR REPRODUCED, TRANSFERRED OR INCORPORATED IN ANY OTHER PROJECT IN ANY MANNER WITHOUT THE EXPRESS WRITTEN CONSENT OF SAMTEC, INC.

DO NOT SCALE DRAWING

SHEET SCALE: 2:1



520 PARK EAST BLVD, NEW ALBANY, IN 47150  
 PHONE: 812-944-6733 FAX: 812-948-5047  
 e-Mail info@SAMTEC.com code 55322

DESCRIPTION:  
 .050 x .050 CL THROUGH HOLE TERMINAL STRIP

DWG. NO.  
**FTSH-1XX-XX-XXX-D-XXX-XX**

BY: J. FERRY 02/27/1996 SHEET 3 OF 3