

DO NOT SCALE FROM THIS PRINT

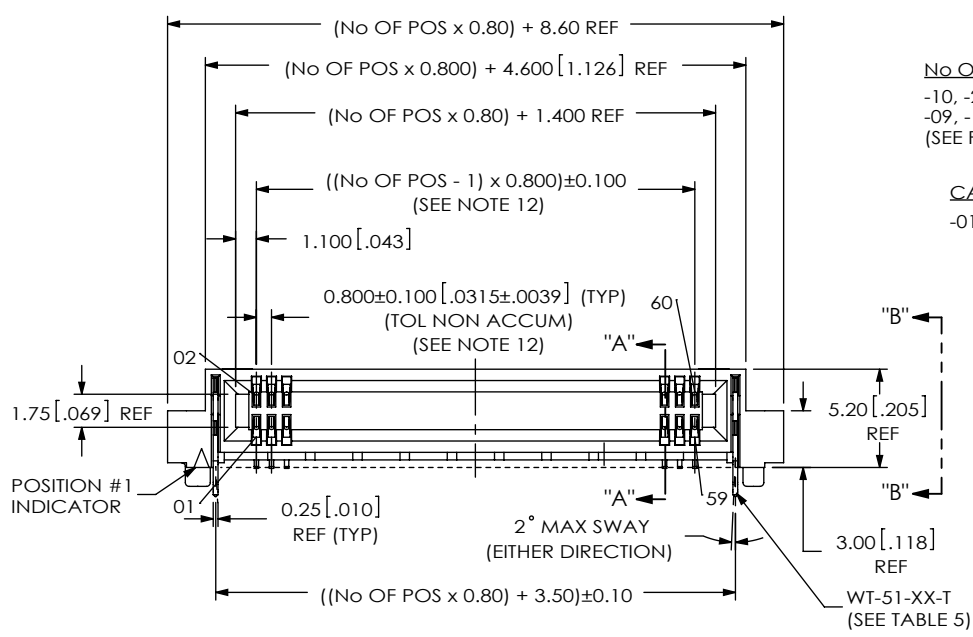

HSEC8-1XX-XX-X-RA-XX-XX

**No OF POSITIONS**  
 -10, -20, -30 (SEE FIG 1)  
 -09, -13, -25, -40, -49, -50, -60 (SEE FIG 2)

**CARD THICKNESS**  
 -01: 1.57mm [.062] THICK CARD

**PLATING SPECIFICATION**  
 -L: 10µ" SELECTIVE GOLD ON CONTACT AREA, TIN TAIL  
 -S: 30µ" SELECTIVE GOLD ON CONTACT AREA, TIN TAIL

(\* = NOT TOOLED)

**PACKAGING**  
 -TR: TAPE & REEL

**OPTION**  
 -BL: BOARD LOCK OPTION (USE HSEC8-XXX-01-RA-BL) (AVAILABLE IN -09, -13, \*-20, 25, 40, -49, 50, 60 POS ONLY, SEE FIG 3, SHT 8)  
 -L2: ECDP LATCHING OPTION (USE HSEC8-XXX-01-RA-L2) (AVAILABLE IN -09, -13, -25, -49 POS ONLY, SEE FIG 4, SHT 9)

**ROW SPECIFICATION**  
 -RA: RIGHT ANGLE (USE HSEC8-XXX-01-RA-XX)

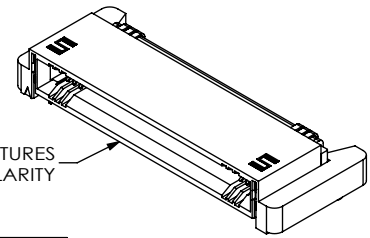

SOME CENTER FEATURES NOT SHOWN FOR CLARITY

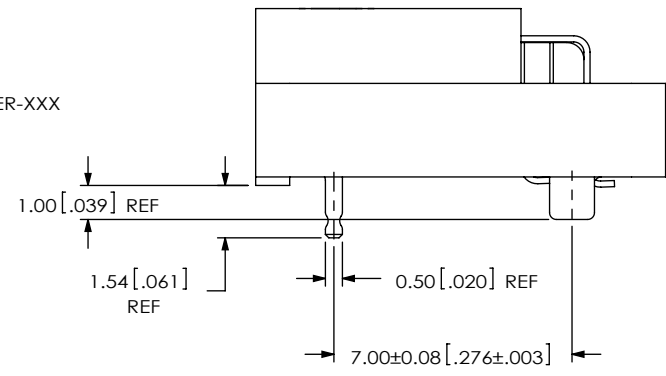
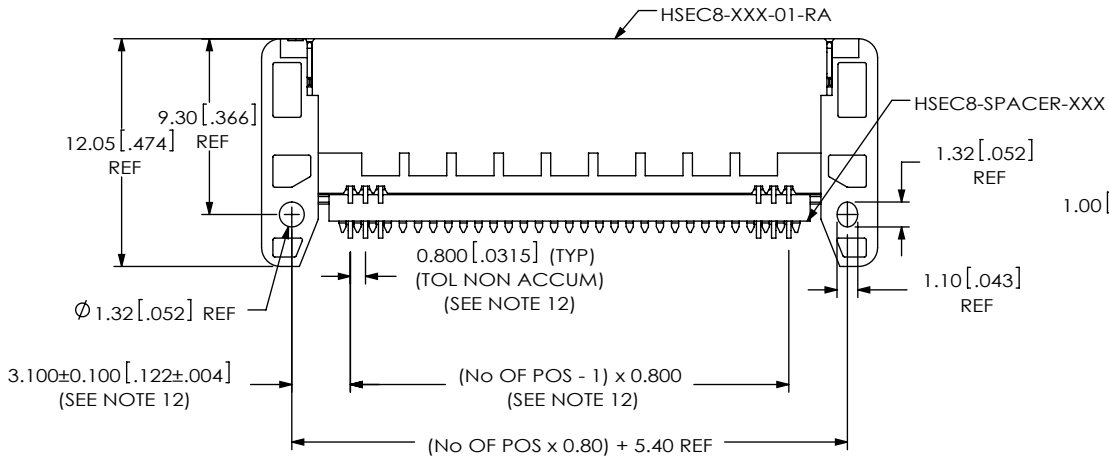

SECTION "B"-"B"  
 SCALE 4.5 : 1

FIG 1  
 FOR POSITIONS -10, -20 & -30  
 HSEC8-130-01-X-RA SHOWN  
 (SOME CENTER FEATURES NOT SHOWN FOR CLARITY)

- NOTES:
- ① REPRESENTS A CRITICAL DIMENSION.
  - MAXIMUM BURR ALLOWANCE: 0.038 [.0015]
  - MINIMUM RETENTION FORCE: 2.22N [.500 LB] FOR PINS AND WELD TAB.
  - MEASURE AT BEND TANGENCY.
  - NOTE DELETED.
  - PARTS TO BE PACKAGED IN TRAY, UNLESS -TR OPTION IS SPECIFIED.
  - NOTE DELETED.
  - DIMENSIONS MUST BE MEASURED ON BOTH ENDS OF THE CONNECTOR.  
 IF PINS WERE HAND FORMED, MEASURE ONE PIN ONLY (IF APPLICABLE) ON EACH END.  
 IF PINS WERE AUTOMATION FORMED, MEASURE 4 CONSECUTIVE PINS ON EACH END.
  - NOTE DELETED.
  - NOTE DELETED.
  - LTC-XX TO BE IN CLOSED POSITION AS SHOWN.
  - MEASURE BOTH TOP AND BOTTOM ROWS.
  - DIMENSIONS TO BE MEASURED ON 4 CONSECUTIVE PINS IF AUTOMATION FORMED.  
 MEASURED ON ONE PIN FROM EACH END OF COMB IF HAND FORMED.
  - SEE CO-AU-WI-3163-M DOCUMENT FOR CRITICAL MEASUREMENT SPECIAL INSTRUCTIONS.

TABLE 5	
OPTION	WT-51-XX-T
NO OPTION	WT-51-01-T
-BL	WT-51-01-T
-L2	WT-51-02-T

UNLESS OTHERWISE SPECIFIED, DIMENSIONS ARE IN MILLIMETERS. TOLERANCES ARE:  
 DECIMALS ANGLES  
 X.X: ±0.3 [.01] 2°  
 X.XX: ±0.13 [.005]  
 X.XXX: ±0.051 [.0020]

**PROPRIETARY NOTE**  
 THIS DOCUMENT CONTAINS INFORMATION CONFIDENTIAL AND PROPRIETARY TO SAMTEC, INC. AND SHALL NOT BE REPRODUCED OR TRANSFERRED TO OTHER DOCUMENTS OR DISCLOSED TO OTHERS OR USED FOR ANY PURPOSE OTHER THAN THAT WHICH IT WAS OBTAINED WITHOUT THE EXPRESSED WRITTEN CONSENT OF SAMTEC, INC.

**samtec**  
 520 PARK EAST BLVD. NEW ALBANY, IN 47150  
 PHONE: 812-944-6733 FAX: 812-948-5047  
 e-Mail: info@SAMTEC.com code 55322

**MATERIAL:** DO NOT SCALE DRAWING SHEET SCALE: 2.5:1  
 INSULATOR: LCP UL94V-0, COLOR: BLACK  
 CONTACT: BeCu  
 WELD TAB: BRASS

**DESCRIPTION:**  
 0.8MM HIGH SPEED ASSEMBLY  
**DWG. NO.**  
 HSEC8-1XX-XX-X-RA-XX-XX

REVISION AC

TABLE 1		
COPLANARITY	TOP ROW STRAIGHTNESS	BTM ROW STRAIGHTNESS
0.10 [.004]	0.10 [.004]	0.10 [.004]

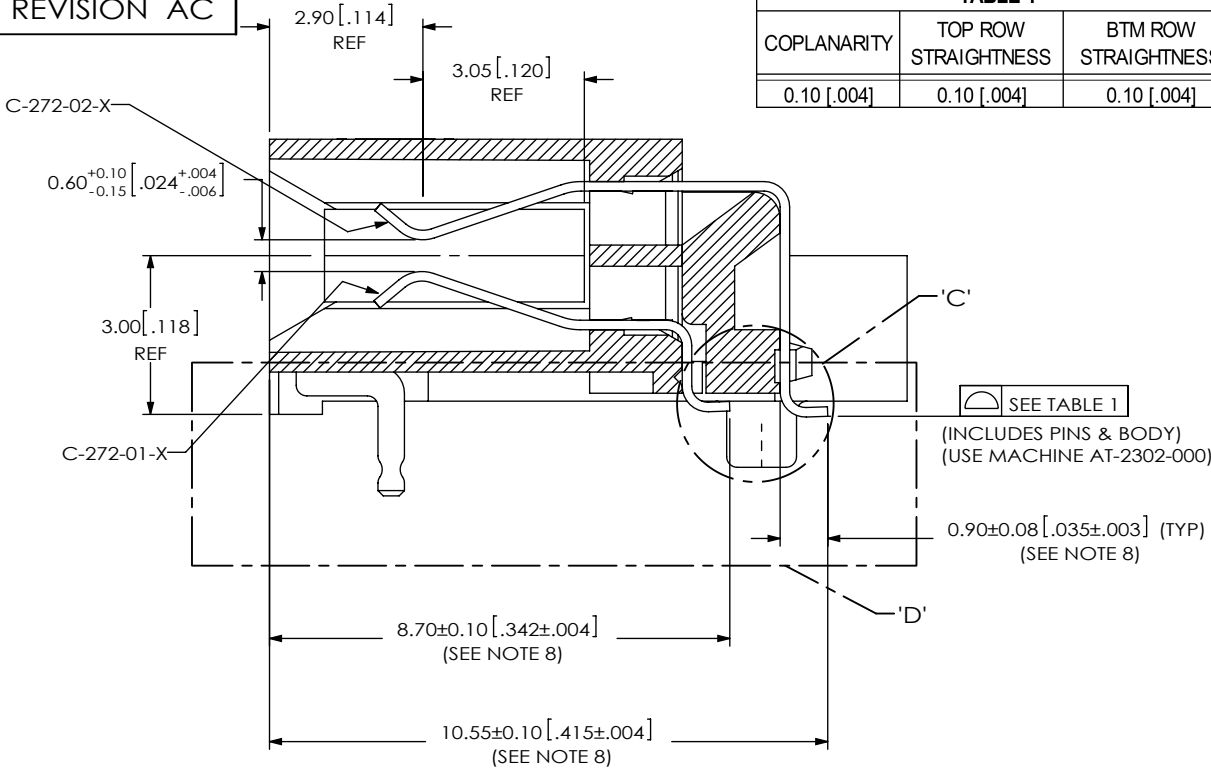

SECTION "A"-"A"

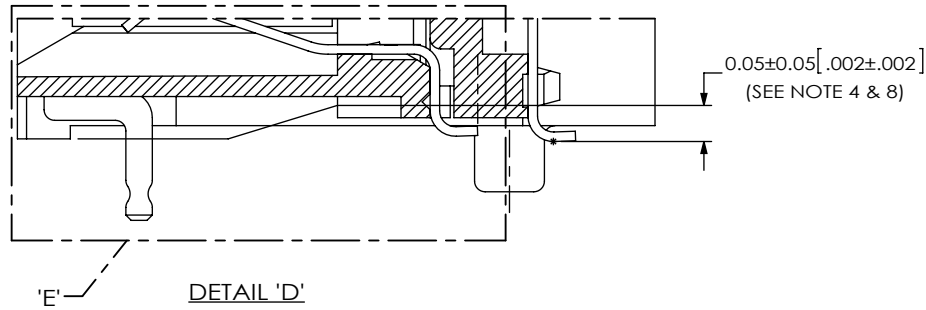

DETAIL 'D'

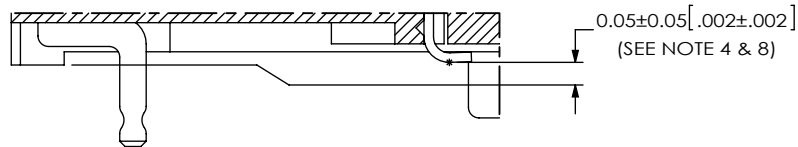

DETAIL 'E'

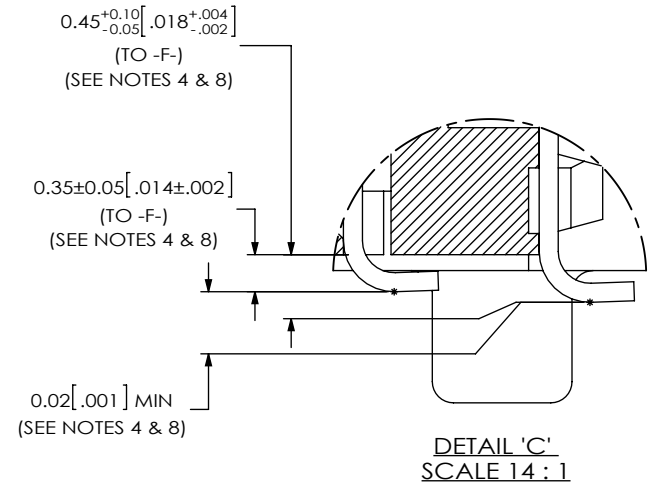
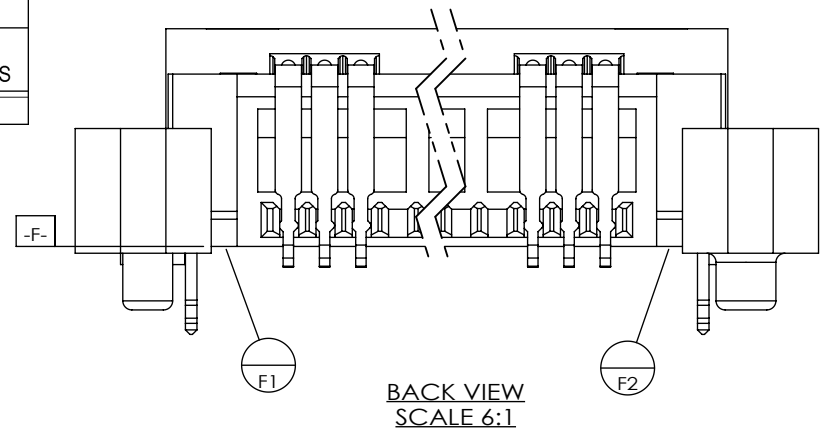

**PROPRIETARY NOTE**  
 THIS DOCUMENT CONTAINS INFORMATION CONFIDENTIAL AND PROPRIETARY TO SAMTEC, INC. AND SHALL NOT BE REPRODUCED OR TRANSFERRED TO OTHER DOCUMENTS OR DISCLOSED TO OTHERS OR USED FOR ANY PURPOSE OTHER THAN THAT WHICH IT WAS OBTAINED WITHOUT THE EXPRESSED WRITTEN CONSENT OF SAMTEC, INC.

DO NOT SCALE DRAWING

SHEET SCALE: 7:1

**samtec**

520 PARK EAST BLVD, NEW ALBANY, IN 47150  
 PHONE: 812-944-6733 FAX: 812-948-5047  
 e-Mail info@SAMTEC.com code 55322

DESCRIPTION:  
 0.8MM HIGH SPEED ASSEMBLY

DWG. NO.  
 HSEC8-1XX-XX-X-RA-XX-XX

BY: ROY LUO 11/05/2008 SHEET 2 OF 9

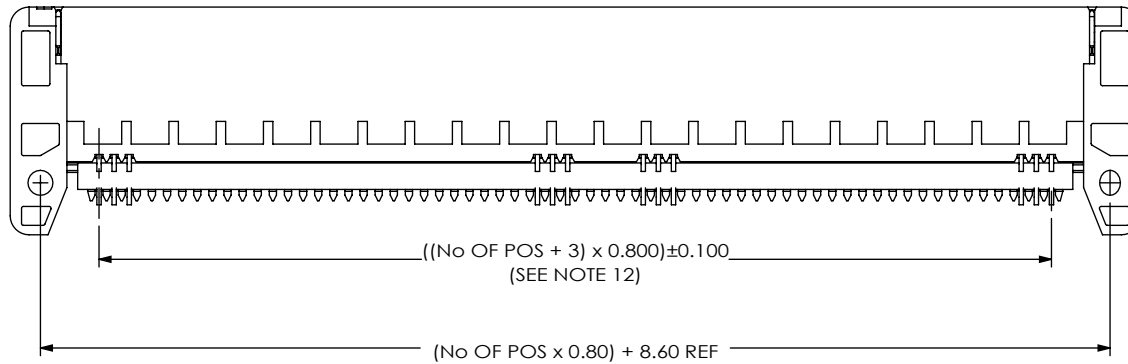
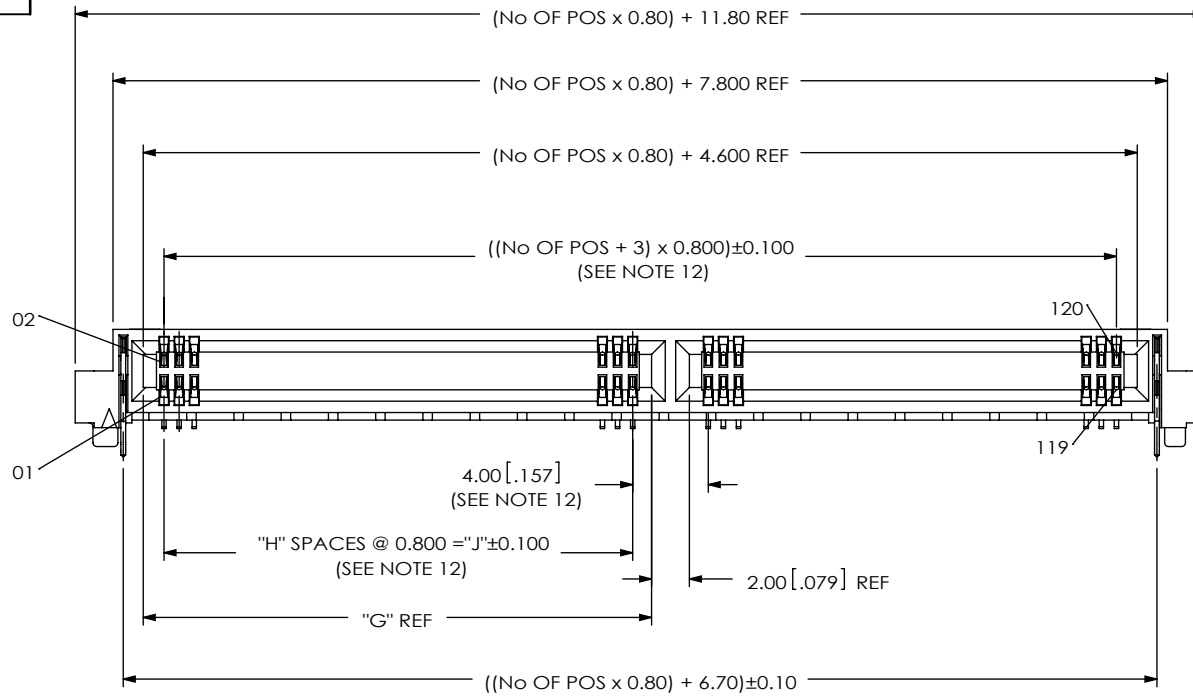

**FIG 2**  
 FOR POSITIONS -09, -13, -25, -40, -49, -50, -60  
 SAME AS FIG 1, UNLESS OTHERWISE STATED  
 HSEC8-160-01-X-RA SHOWN  
 (SOME CENTER FEATURES NOT SHOWN FOR CLARITY)

TABLE 2			
No OF POSITIONS	"G"	"H"	"J"
-09	4.500	3	2.400
-13	6.100	5	4.000
-25	6.100	5	4.000
-40	18.900	21	16.800
-49	22.900	26	20.800
-50	22.900	26	20.800
-60	26.900	31	24.800

**PROPRIETARY NOTE**  
 THIS DOCUMENT CONTAINS INFORMATION CONFIDENTIAL AND PROPRIETARY TO SAMTEC, INC. AND SHALL NOT BE REPRODUCED OR TRANSFERRED TO OTHER DOCUMENTS OR DISCLOSED TO OTHERS OR USED FOR ANY PURPOSE OTHER THAN THAT WHICH IT WAS OBTAINED WITHOUT THE EXPRESSED WRITTEN CONSENT OF SAMTEC, INC.

DO NOT SCALE DRAWING

SHEET SCALE: 2.5:1

**samtec**  
 520 PARK EAST BLVD, NEW ALBANY, IN 47150  
 PHONE: 812-944-6733 FAX: 812-948-5047  
 e-Mail info@SAMTEC.com code 55322

DESCRIPTION:  
 0.8MM HIGH SPEED ASSEMBLY

DWG. NO.  
**HSEC8-1XX-XX-X-RA-XX-XX**

BY: ROY LUO 11/05/2008 SHEET 3 OF 9

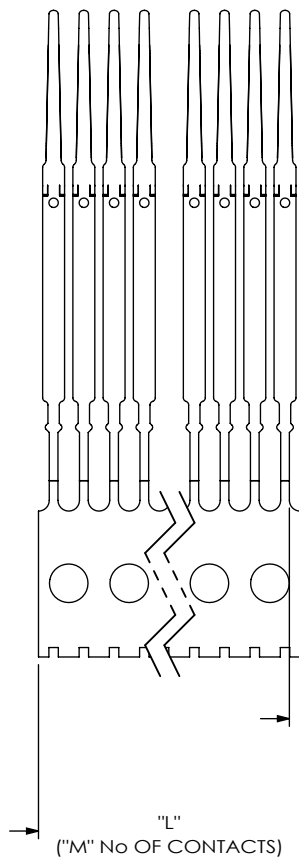
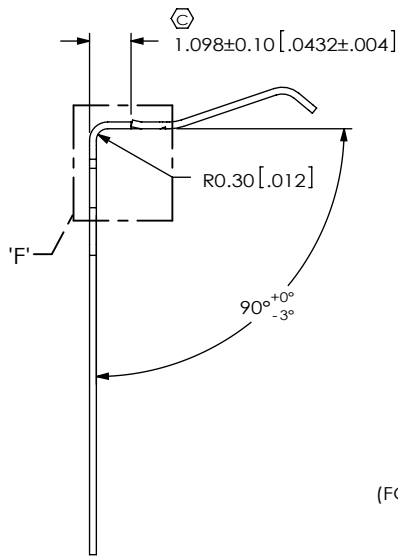

TABLE 3

POSITION	HAND FORM			AUTOMATION FORM		
	"L"	"M"	"N"	"L"	"M"	"N"
-09	10.41 [.410]	13	0.29	11.21 [.441]	14	1.09
-10	8.01 [.315]	10	0.29	8.01 [.315]	10	0.29
-13	13.61 [.536]	17	0.29	14.41 [.567]	18	1.09
-20	16.01 [.630]	20	0.29	16.01 [.630]	20	0.29
-25	23.21 [.914]	29	0.29	24.01 [.945]	30	1.09
-30	24.01 [.945]	30	0.29	24.01 [.945]	30	0.29
-40	35.21 [1.386]	44	0.29	36.81 [1.449]	46	1.09
-49	42.41 [1.670]	53	0.29	43.21 [1.701]	54	1.09
-50	43.21 [1.701]	54	0.29	43.21 [1.701]	54	0.29
-60	51.21 [2.016]	64	0.29	52.81 [2.079]	66	1.09

IN-PROCESS 1 & 2  
(COMB CUT CONTACT  
C-272-01-X & C-272-02-X)  
(USE FIXTURE AT-2194-815)



IN-PROCESS 2  
(FORM 1 CONTACT C-272-01-X)  
(USE FIXTURE AT-2194-815)  
(RIGHT SIDE SHOWN)  
(SEE NOTE 13)  
(ONLY APPLICABLE FOR HAND FORMING PINS)

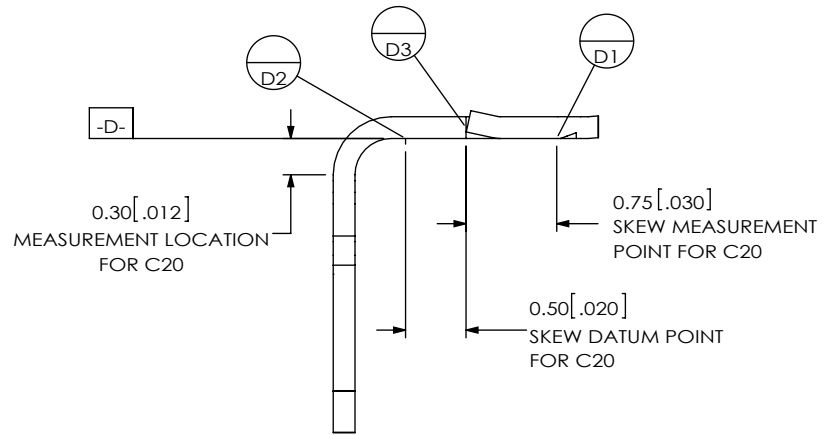

DETAIL 'F'  
SCALE 16:1

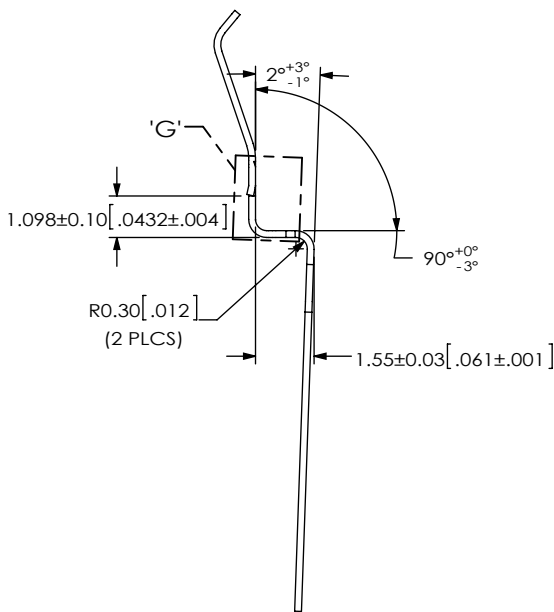

IN-PROCESS 3  
(FORM 2 CONTACT C-272-01-X)  
(USE FIXTURE AT-2194-815)  
(RIGHT SIDE SHOWN)  
(SEE NOTE 13)

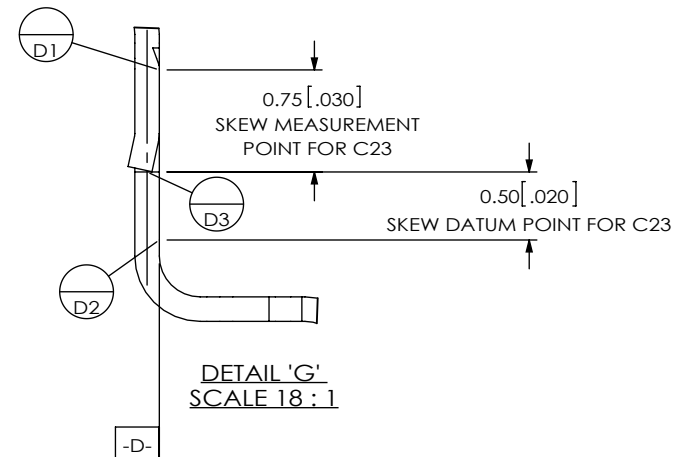

DETAIL 'G'  
SCALE 18:1

c:\enterprisevault\DWG\MISC\MKTG\HSEC8-1XX-XX-X-RA-XX-XX-MKT.SLDDRW

PROPRIETARY NOTE

THIS DOCUMENT CONTAINS INFORMATION  
CONFIDENTIAL AND PROPRIETARY TO  
SAMTEC, INC. AND SHALL NOT BE REPRODUCED  
OR TRANSFERRED TO OTHER DOCUMENTS OR  
DISCLOSED TO OTHERS OR USED FOR ANY  
PURPOSE OTHER THAN THAT WHICH IT WAS  
OBTAINED WITHOUT THE EXPRESSED WRITTEN  
CONSENT OF SAMTEC, INC.

DO NOT SCALE DRAWING

SHEET SCALE: 5:1



520 PARK EAST BLVD, NEW ALBANY, IN 47150  
PHONE: 812-944-6733 FAX: 812-948-5047  
e-Mail info@SAMTEC.com code 55322

DESCRIPTION:  
0.8MM HIGH SPEED ASSEMBLY

DWG. NO.  
HSEC8-1XX-XX-X-RA-XX-XX

BY: ROY LUO 11/05/2008 SHEET 4 OF 9

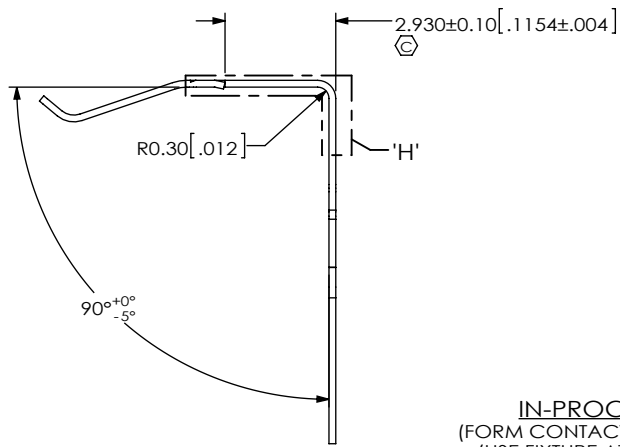

**IN-PROCESS 8**  
 (FORM CONTACT C-272-02-X)  
 (USE FIXTURE AT-2194-815)  
 (LEFT SIDE SHOWN)  
 (SEE NOTE 13)  
 (ONLY APPLICABLE FOR HAND FORMING PINS)

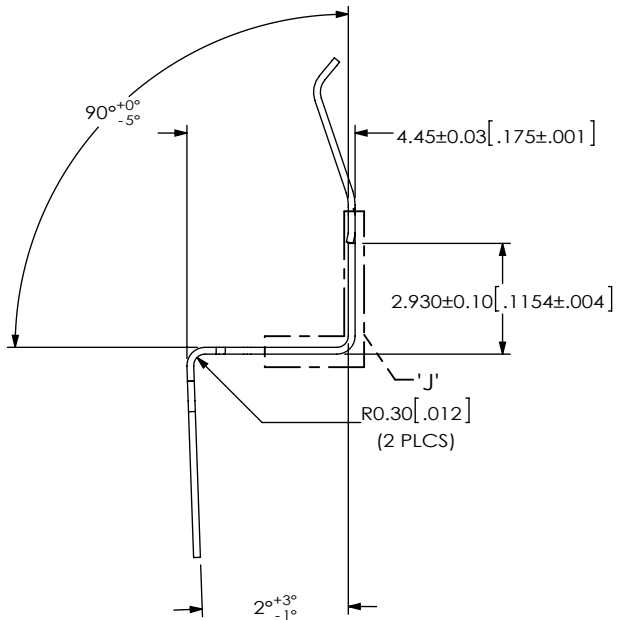
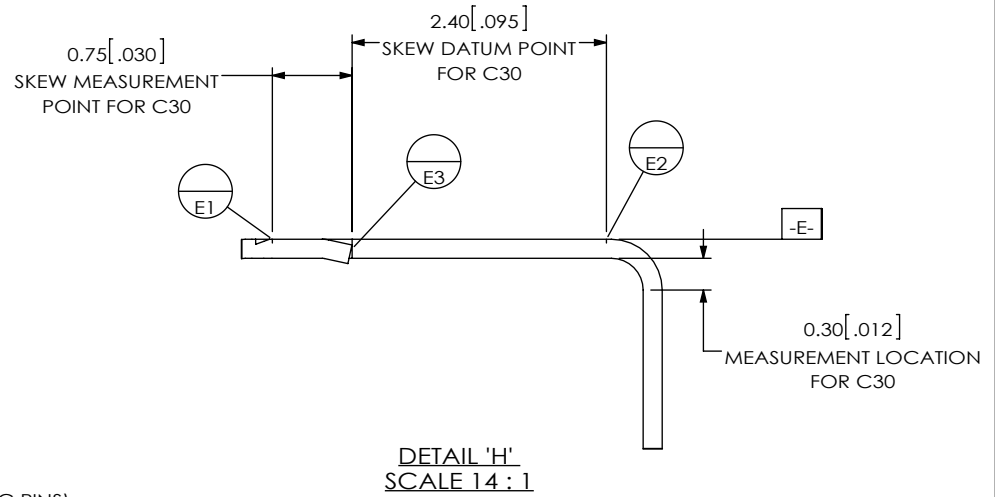

**IN-PROCESS 9**  
 (FORM CONTACT C-272-02-X)  
 (USE FIXTURE AT-2194-815)  
 (LEFT SIDE SHOWN)  
 (SEE NOTE 13)

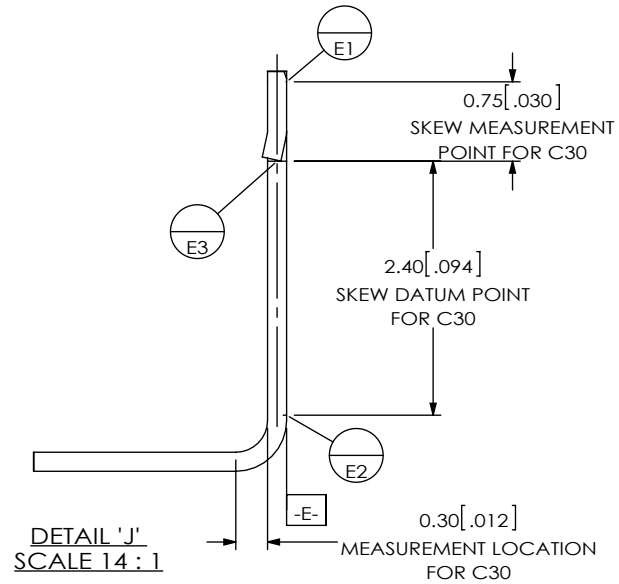

**PROPRIETARY NOTE**  
 THIS DOCUMENT CONTAINS INFORMATION CONFIDENTIAL AND PROPRIETARY TO SAMTEC, INC. AND SHALL NOT BE REPRODUCED OR TRANSFERRED TO OTHER DOCUMENTS OR DISCLOSED TO OTHERS OR USED FOR ANY PURPOSE OTHER THAN THAT WHICH IT WAS OBTAINED WITHOUT THE EXPRESSED WRITTEN CONSENT OF SAMTEC, INC.

DO NOT SCALE DRAWING

SHEET SCALE: 5:1





520 PARK EAST BLVD, NEW ALBANY, IN 47150  
 PHONE: 812-944-6733 FAX: 812-948-5047  
 e-Mail info@SAMTEC.com code 55322

DESCRIPTION:  
 0.8MM HIGH SPEED ASSEMBLY

DWG. NO.  
 HSEC8-1XX-XX-X-RA-XX-XX

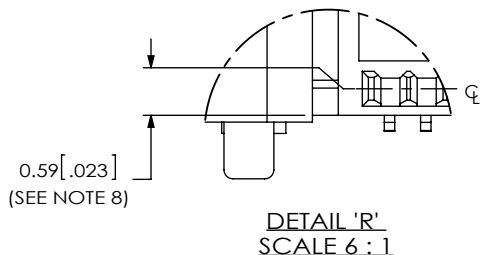
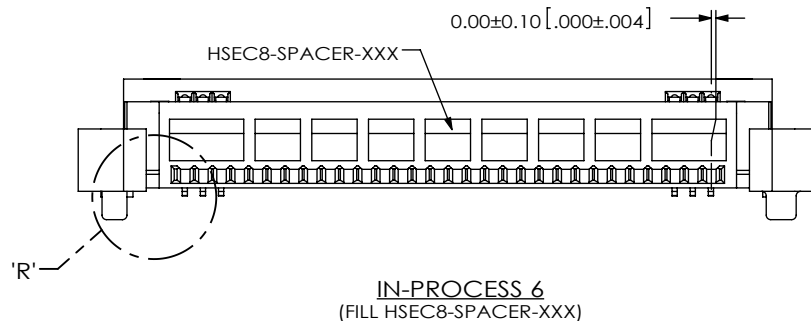
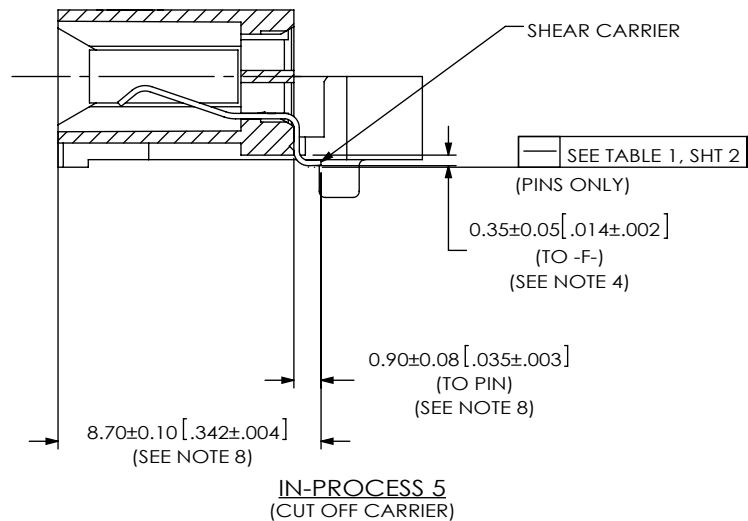
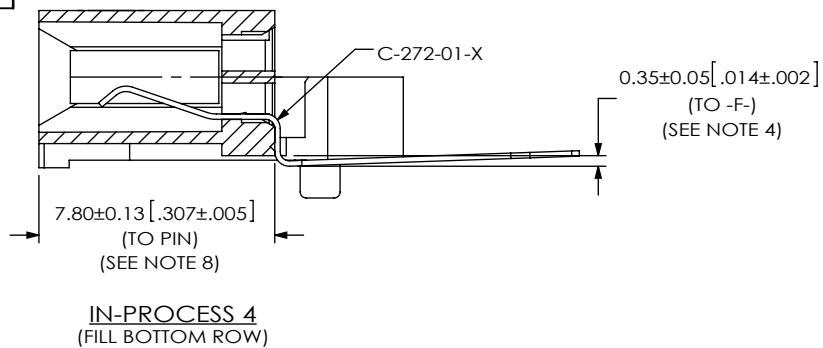
BY: ROY LUO 11/05/2008 SHEET 5 OF 9



<p><b>PROPRIETARY NOTE</b> THIS DOCUMENT CONTAINS INFORMATION CONFIDENTIAL AND PROPRIETARY TO SAMTEC, INC. AND SHALL NOT BE REPRODUCED OR TRANSFERRED TO OTHER DOCUMENTS OR DISCLOSED TO OTHERS OR USED FOR ANY PURPOSE OTHER THAN THAT WHICH IT WAS OBTAINED WITHOUT THE EXPRESSED WRITTEN CONSENT OF SAMTEC, INC.</p> <p>DO NOT SCALE DRAWING</p> <p>SHEET SCALE: 4:1</p>		
	<p>520 PARK EAST BLVD, NEW ALBANY, IN 47150 PHONE: 812-944-6733 FAX: 812-948-5047 e-Mail info@SAMTEC.com code 55322</p>	
	<p>DESCRIPTION: <b>0.8MM HIGH SPEED ASSEMBLY</b></p>	
	<p>DWG. NO. <b>HSEC8-1XX-XX-X-RA-XX-XX</b></p>	
<p>BY: ROY LUO 11/05/2008</p>		<p>SHEET 6 OF 9</p>

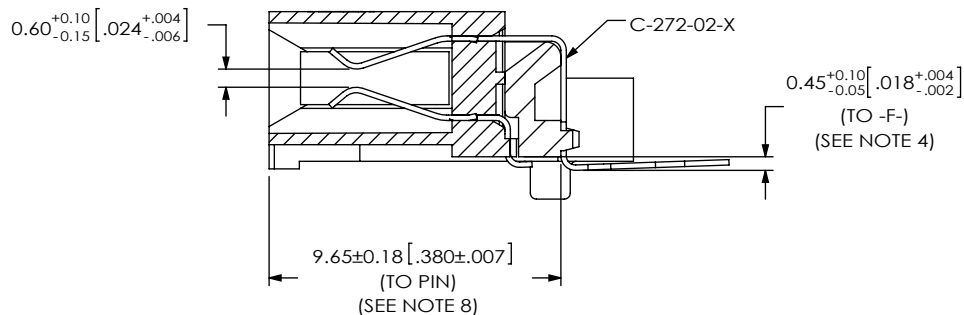

**IN-PROCESS 10**  
(FILL TOP ROW)

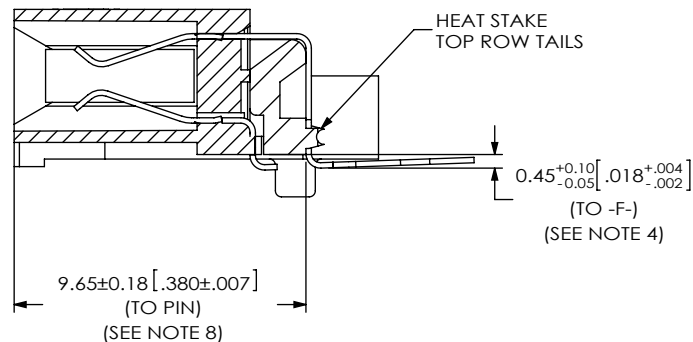

**IN-PROCESS 11**  
(HEAT STAKE TOP ROW CONTACTS)

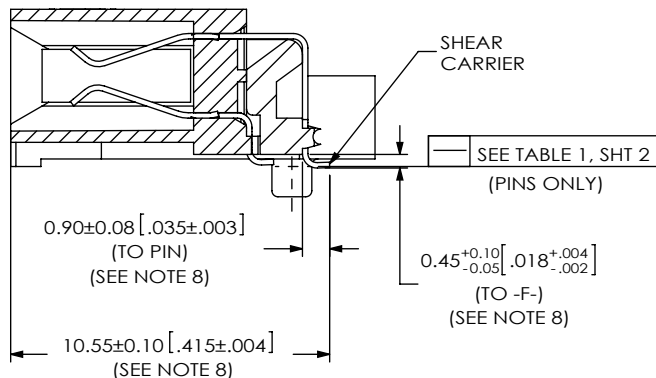

**IN-PROCESS 12**  
(CUT OFF CARRIER)

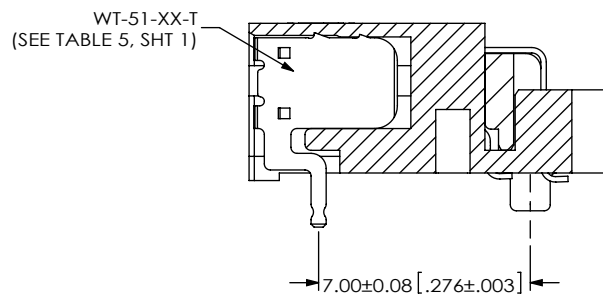

**IN-PROCESS 13**  
(FILL WT-51-XX-T)

**PROPRIETARY NOTE**

THIS DOCUMENT CONTAINS INFORMATION CONFIDENTIAL AND PROPRIETARY TO SAMTEC, INC. AND SHALL NOT BE REPRODUCED OR TRANSFERRED TO OTHER DOCUMENTS OR DISCLOSED TO OTHERS OR USED FOR ANY PURPOSE OTHER THAN THAT WHICH IT WAS OBTAINED WITHOUT THE EXPRESSED WRITTEN CONSENT OF SAMTEC, INC.

DO NOT SCALE DRAWING

SHEET SCALE: 4:1



520 PARK EAST BLVD, NEW ALBANY, IN 47150  
PHONE: 812-944-6733 FAX: 812-948-5047  
e-Mail info@SAMTEC.com code 55322

DESCRIPTION:  
0.8MM HIGH SPEED ASSEMBLY

DWG. NO.  
**HSEC8-1XX-XX-X-RA-XX-XX**

BY: ROY LUO 11/05/2008 SHEET 7 OF 9

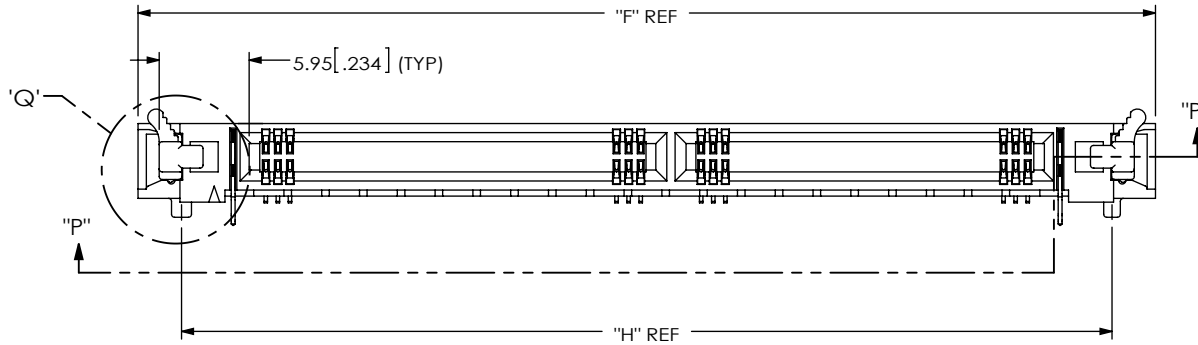
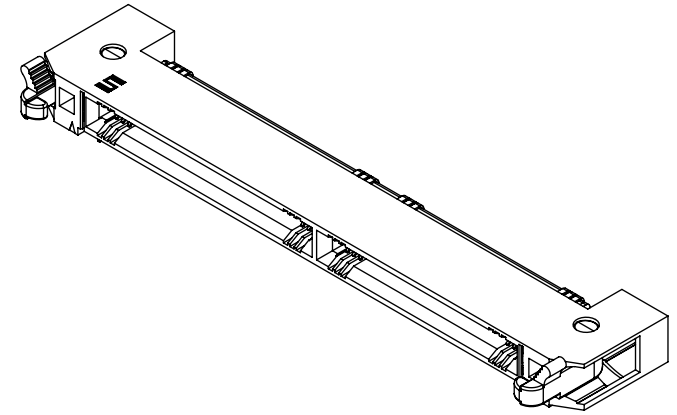
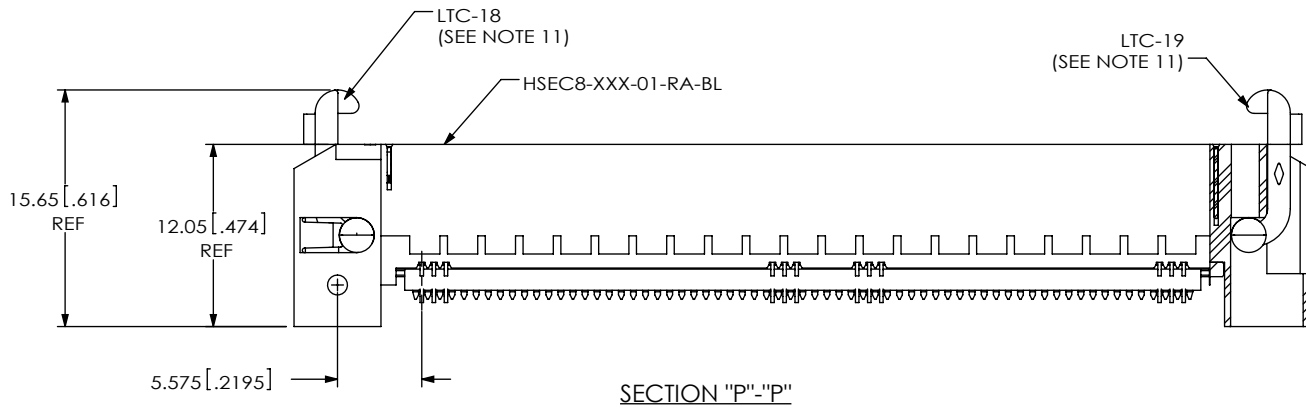

**FIG 3**  
 -BL: BOARD LOCK OPTION ONLY AVAILABLE  
 FOR -09, -13, \*-20, -25, -40, -49, -50, -60 POSITIONS  
 (FOR -09, -13, -25, -40, -49, -50, -60 POSITIONS, SAME AS FIG 2, UNLESS OTHERWISE STATED)  
 (FOR \*-20 POSITION, SAME AS FIG 2, UNLESS OTHERWISE STATED)  
 HSEC8-160-01-X-RA-BL SHOWN  
 (SOME CENTER FEATURES NOT SHOWN FOR CLARITY)  
 (\* = NOT TOOLED)

No OF POSITIONS	"F"	"H"
-009	26.50	20.75
-013	29.70	23.95
*-020	32.10	26.35
-025	39.30	33.55
-040	51.30	45.55
-049	58.50	52.75
-050	59.30	53.55
-060	67.30	61.55

\* = NOT TOOLED

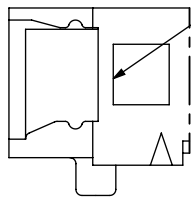

DETAIL 'Q'  
 SCALE 4 : 1

LTC-XX REMOVED FOR CLARITY

**PROPRIETARY NOTE**

THIS DOCUMENT CONTAINS INFORMATION CONFIDENTIAL AND PROPRIETARY TO SAMTEC, INC. AND SHALL NOT BE REPRODUCED OR TRANSFERRED TO OTHER DOCUMENTS OR DISCLOSED TO OTHERS OR USED FOR ANY PURPOSE OTHER THAN THAT WHICH IT WAS OBTAINED WITHOUT THE EXPRESSED WRITTEN CONSENT OF SAMTEC, INC.

DO NOT SCALE DRAWING

SHEET SCALE: 2:1



520 PARK EAST BLVD, NEW ALBANY, IN 47150  
 PHONE: 812-944-6733 FAX: 812-948-5047  
 e-Mail info@SAMTEC.com code 55322

DESCRIPTION:  
 0.8MM HIGH SPEED ASSEMBLY

DWG. NO.  
**HSEC8-1XX-XX-X-RA-XX-XX**

BY: ROY LUO 11/05/2008 SHEET 8 OF 9



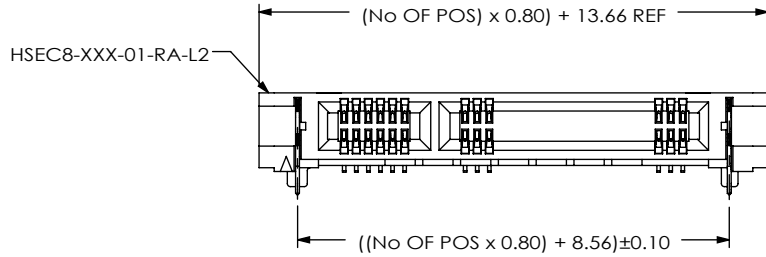
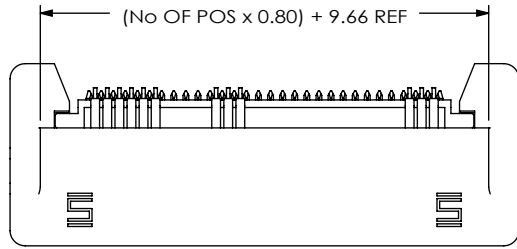

**FIG 4**  
 -L2: ECDP LATCHING OPTION  
 AVAILABLE ONLY IN -09, -13, -25 & -49 POSITIONS  
 SAME AS FIG 2, UNLESS OTHERWISE STATED  
 HSEC8-125-01-X-RA-L2 SHOWN

<p><b>PROPRIETARY NOTE</b>                  THIS DOCUMENT CONTAINS INFORMATION CONFIDENTIAL AND PROPRIETARY TO SAMTEC, INC. AND SHALL NOT BE REPRODUCED OR TRANSFERRED TO OTHER DOCUMENTS OR DISCLOSED TO OTHERS OR USED FOR ANY PURPOSE OTHER THAN THAT WHICH IT WAS OBTAINED WITHOUT THE EXPRESSED WRITTEN CONSENT OF SAMTEC, INC.</p> <p>DO NOT SCALE DRAWING</p> <p>SHEET SCALE: 2:1</p>			
	<p>520 PARK EAST BLVD, NEW ALBANY, IN 47150                  PHONE: 812-944-6733 FAX: 812-948-5047                  e-Mail info@SAMTEC.com code 55322</p>		
	<p>DESCRIPTION:                  0.8MM HIGH SPEED ASSEMBLY</p>		
	<p>DWG. NO.                  HSEC8-1XX-XX-X-RA-XX-XX</p>		
	<p>BY: ROY LUO</p>	<p>11/05/2008</p>	<p>SHEET 9 OF 9</p>