CloudSpeed Eco and Ultra Gen. II 2.5" SATA Solid State Drive, Generic

Document Number: 80-11-80106

Legal Disclaimer

The SanDisk Corporation general policy does not recommend the use of its products in life support applications wherein a failure or malfunction of the product may directly threaten life or injury. Without limitation to the foregoing, SanDisk shall not be liable for any loss, injury, or damage caused by use of its products in any of the following applications:

- Special applications such as military related equipment, nuclear reactor control, and aerospace.
- Control devices for transportation equipment, including automotive vehicles, trains, ships, and traffic equipment.
- Safety systems for disaster prevention and crime prevention.
- Medical-related equipment (including medical measurement devices).

Accordingly, in any use of SanDisk products in life support systems or other applications where failure could cause damage, injury, or loss of life, the products should only be incorporated in systems designed with appropriate redundancy, fault tolerant, or back-up features. Per SanDisk Terms and Conditions of Sale, the user of SanDisk products in life support or other such applications assumes all risk of such use and agrees to indemnify, defend, and hold harmless SanDisk Corporation and its affiliates against all damages.

Security safeguards, by their nature, are capable of circumvention. SanDisk cannot, and does not, guarantee that data will not be accessed by unauthorized persons, and SanDisk disclaims any warranties to that effect to the fullest extent permitted by law.

This document and related material are for informational use only and are subject to change without prior notice. SanDisk Corporation assumes no responsibility for any errors that may appear in this document or related material, nor for any damages or claims resulting from the furnishing, performance, or use of this document or related material. Absent a written agreement signed by SanDisk Corporation or its authorized representative to the contrary, SanDisk Corporation explicitly disclaims any express and implied warranties and indemnities of any kind that may, or could, be associated with this document and related material, and any user of this document or related material agrees to such disclaimer as a precondition to receipt and usage hereof. EACH USER OF THIS DOCUMENT EXPRESSLY WAIVES ALL GUARANTIES AND WARRANTIES OF ANY KIND ASSOCIATED WITH THIS DOCUMENT AND/OR RELATED MATERIALS, WHETHER EXPRESSED OR IMPLIED, INCLUDING WITHOUT LIMITATION, ANY IMPLIED WARRANTY OF MERCHANTABILITY OR FITNESS FOR A PARTICULAR PURPOSE OR INFRINGEMENT, TOGETHER WITH ANY LIABILITY OF SANDISK CORPORATION AND ITS AFFILIATES UNDER ANY CONTROL, NEGLIGENCE, STRICT LIABILITY OF SANDISK CORPORATION AND ITS AFFILIATES UNDER ANY CONTRACT, PROFIT OR OTHER INCIDENTAL, PUNITIVE, INDIRECT, SPECIAL, OR CONSEQUENTIAL DAMAGES, INCLUDING WITHOUT LIMITATION PHYSICAL INJURY OR DEATH, PROPERTY DAMAGE, LOST DATA, OR COSTS OF PROCUREMENT OF SUBSTITUTE GOODS, TECHNOLOGY, OR SERVICES.

This document and its contents, including diagrams, schematics, methodology, work product, and intellectual property rights described in, associated with, or implied by this document, are the sole and exclusive property of SanDisk Corporation and its applicable subsidiaries ("SanDisk"). No intellectual property license, expressed or implied, is granted by SanDisk associated with the document recipient's receipt, access and/or use of this document; SanDisk retains all rights hereto.

No work for hire, nor any form of joint ownership, is granted or implied by the document recipient's receipt, access and/or use of this document.

Any work requested (or implied by the document recipient to be requested) to SanDisk associated with this document and/or its contents, shall be the sole and exclusive property of SanDisk, except to the extent, if any, expressly agreed otherwise by SanDisk in writing referencing this document.

This document, and SanDisk's communications to the user associated therewith, shall be treated as SanDisk's proprietary and confidential information, protected by the recipient as such, and used by the recipient only for the purpose authorized in writing by SanDisk. This document shall be covered as SanDisk's confidential information under all applicable nondisclosure agreements between the recipient and SanDisk.

No part of this document may be reproduced, transmitted, transcribed, stored in a retrievable manner, or translated into any language or computer language, in any form or by any means, electronic, mechanical, magnetic, optical, chemical, manual, or otherwise, without the prior written consent of an officer of SanDisk Corporation.

All parts of the SanDisk documentation are protected by copyright law and all rights are reserved. SanDisk and the SanDisk logo are registered trademarks of SanDisk Corporation, registered in the United States and other countries. Other brand names mentioned herein are for identification purposes only and may be the trademarks of their respective holder(s). Copyright 2015 SanDisk Corporation. All rights reserved.

Revision History

	Revision	Section(s)	Description
October 2015	3	1.4.1	Reliability
August 2015	2	5.1	Added Security Disable Password (F6) as a SATA command.
July 2015	1	All	Preliminary release.

ESD Caution – Handling



Static electricity may be discharged through this disk subsystem. In extreme cases, this may temporarily interrupt the operation or damage components. To prevent this, make sure you are working in an ESD-safe environment. For example, before handling the disk subsystem, touch a grounded device, such as a computer case.

Table of Contents

Contents	Pages
1.0 General Description	5
1.1 Overview	5
1.2 Features	6
1.3 Unique Features	7
1.4 Operational Characteristics	8
1.4.1 Reliability.....	8
2.0 Product Description	10
2.1 Functional Block Diagram.....	10
2.2 Flash Management.....	10
2.3 Endurance.....	11
2.3.1 Aggregated Flash Management.....	11
2.3.2 Advanced Signal Processing.....	11
2.4 Temperature Throttling.....	11
2.5 Mean Time Between Failures (MTBF)	11
2.6 Regulatory Standards Compliance.....	12
3.0 Mechanical Specifications.....	13
3.1 Physical Specifications	13
3.2 Drive Mounting.....	13
4.0 Electrical Specifications.....	15
4.1 Electrical Interface.....	15
4.1.1 CloudSpeed Interface Connector and Pinout Descriptions.....	15
4.2 Remote LED.....	16
4.3 Thermal Sensor	16
4.4 Power.....	16
4.4.1 DC Noise and Ripple.....	16
4.4.2 DC Input Voltage.....	16
4.4.3 Hot Plug.....	16
4.4.4 Power Consumption	17
4.4.5 Absolute Maximum Ratings.....	17
5.0 Software Specifications.....	18
5.1 Enterprise SATA Implementation.....	18
5.2 Device Identification Information	20
5.3 Set Features Subcommands	20
5.4 Supported SMART Operations	21
6.0 Warranty and Part Numbers.....	24
6.1 Warranty.....	24

Table of Contents

Contents	Pages
6.2 Part Numbering Information	24

1.0 General Description

1.1 Overview

The SanDisk CloudSpeed Eco™ and Ultra™ Gen. II solid state drive (SSD) are designed specifically to address the growing need for SSDs that are optimized for read intensive and mixed workload applications in enterprise server and cloud computing environments. Leveraging SanDisk's proprietary Guardian Technology™ platform, tier-one OEM-enterprise firmware, proven power fail technology, and the latest generation of enterprise Multi-Level Cell (eMLC) NAND flash, the CloudSpeed Gen. II SSD offers all the features expected from an enterprise-class drive at the right value.

Available in capacities of 480 GBytes, 960 GBytes, and 1,920 GBytes, the CloudSpeed Eco Gen. II SSD features a 6 Gigabits (Gbits)/sec Serial Advanced Technology Attachment (SATA) interface and provides up to 525/460 megabytes (MBytes)/sec sequential read/write and up to 75,000/13,000 Input/Output Operations Per Second (IOPS) random read/write performance.

Available in capacities of 400 GBytes, 800 GBytes, and 1,600 GBytes, the CloudSpeed Ultra Gen. II SSD features a 6 Gigabits (Gbits)/sec Serial Advanced Technology Attachment (SATA) interface and provides up to 525/460 megabytes (MBytes)/sec sequential read/write and up to 75,000/30,000 Input/Output Operations Per Second (IOPS) random read/write performance.

The CloudSpeed Gen. II is powered by SanDisk's proprietary Guardian Technology platform, a comprehensive suite of innovative features comprised of FlashGuard™, DataGuard™, and EverGuard™ technologies.

FlashGuard extends the native endurance of Multi-Level Cell (MLC) flash-based products. It combines Aggregated Flash Management, which treats all flash elements as a single system, and Advanced Signal Processing, which dynamically adjusts flash parameters throughout the life of the SSD. Using these features, with proprietary-enhanced error-correction techniques, FlashGuard technology provides the endurance enhancements required to enable the use of MLC flash in mission-critical enterprise applications.

CloudSpeed Gen. II implements data path protection using a comprehensive set of features, including:

- ECC and parity protection on internal data path memories
- CRC protection on internal SATA link data paths
- ECC on data resident in flash
- Flexible Redundant Array of Independent Memory Elements (FRAME) and block-level flash data recovery/redundancy

EverGuard protects against loss of user data in the event of unexpected power interruptions using a third-generation backup power circuit design and high-reliability discrete capacitors.

SanDisk has built its reputation by providing proven technology and quality products to the most demanding Fortune 100 OEMs. SanDisk engineers its products to perform at the highest degree of reliability and compatibility.

1.2 Features

- **Type:** 2.5" SATA SSD
- **Interface:** SATA 6 Gbits/sec Interface, Compatible with SATA 1.5 and 3.0 Gbits/sec. Complies with SATA standard version 3.2.
- **Capacities:**
 - CloudSpeed Eco Gen. II: 480 GBytes, 960 GBytes, and 1,920 GBytes
 - CloudSpeed Ultra Gen. II: 400 GBytes, 800 GBytes, and 1,600 GBytes
- **Data Rates¹:**
 - **Sequential Read\Write²:** Up to 525/460 MBytes/sec
 - **Random Read\Write³:**
 - Up to 75,000/13,000 IOPS (CloudSpeed Eco Gen. II)
 - Up to 75,000/30,000 IOPS (CloudSpeed Ultra Gen. II)
- **Operating Temperature⁴:** 0 °C to 70 °C (internal)
- **Compliance:**
 - RoHS
 - Halogen-free
- **Warranty:** 5 years

¹. Max performance is possible on the largest capacity point only.

². Based on 128 KByte transfers.

³. Based on 4 KByte transfers. Final numbers are pending evaluation.

⁴. As measured by internal drive thermal sensors.

1.3 Unique Features

- Drive-specific SMART Attributes
- FlashGuard Technology
 - Extended Endurance of MLC Flash
 - Aggregated Flash Management
 - Advanced Signal Processing
 - Enhanced Error Correction
- DataGuard Technology
 - Protects Against Data Corruption and Loss
 - FRAME Technology
- EverGuard Technology
 - Data Protection in the Event of Unanticipated Power Outages
 - High-reliability Backup Power Circuitry
- Superior Reliability
- Full Die Recovery
- Temperature Throttling
- Field Upgradeable Firmware (Through the SATA Interface)

1.4 Operational Characteristics

All listed values are typical unless otherwise stated.

Table 1: Performance Characteristics

	Eco Performance	Ultra Performance
Sequential Read/Write (maximum)	Up to 525/460 MBytes/sec	Up to 525/460 MBytes/sec
Random Read/Write IOPS (maximum)	Up to 75,000/13,000 IOPS	Up to 75,000/30,000 IOPS
Response Time	< 40 seconds ⁵	< 40 seconds ⁵

1.4.1 Reliability

Table 2: Reliability Characteristics

	Eco Value	Ultra Value
Data Reliability	<1 unrecoverable error in 10 ¹⁸ bits read ⁶	
Data Retention	1 year @ 55 °C, 0% P/E cycles; 3 months @ 40 °C, 100% P/E cycles ⁷	
Endurance (Random Workload)	0.6 DWPD for 5 years ⁸	1.8 DWPD for 5 years ⁸
Mean Time Between Failures	2.0 million hours	
Power Cycles	5,000	

⁵ Response time is measured from power on to ready for media access.

⁶ The JEDEC 64.8 specification requires 1 in 10¹⁶ for enterprise-class SSDs.

⁷ Three-month data retention is based on operating and storage temperatures not to exceed 40 °C.

⁸ Application must manage Drive Writes Per Day (DWPD) throughout the life of the drive to ensure the five-year lifetime for specific workloads. For details about how this is calculated, please reference SanDisk White Paper WP004, *The Why and How of SSD Over Provisioning*.

Environmental Conditions

Table 3: Environmental Test

	Condition	Limits
Altitude	Operating	-1,000 feet to 15,000 feet
	Shipping	-1,000 feet to 40,000 feet
	Storage	-1,000 feet to 40,000 feet
Temperature and Humidity	Operating	Temperature: 0 °C to + 70 °C (internal) Humidity: 5% to 95% non-condensing, relative humidity NOTE: Warranty coverage is voided for drives that record temperatures in excess of 70 °C.
	Shipping/ Storage	Temperature: -40 °C to + 85 °C Humidity: 5% to 95% non-condensing, relative humidity NOTE: Non-operational exposure to temperatures in excess of 40 °C for periods exceeding three months should be avoided. The three-month EOL data retention specification requires storage temperatures do not exceed 40 °C. If necessary, contact SanDisk for further information.
Vibration – Random	Operating	3.22 <i>g</i> rms, 5–1,000 Hz, 15 minutes per axis
	Non-operating	14.5 <i>g</i> rms, 2–1,000 Hz, 15 minutes per axis
Vibration –Swept Sine	Operating	1.0 <i>g</i> peak, 5–300 Hz, 0.5 <i>g</i> peak, 300–500 Hz, sweep rate 0.5 Hz/sec
	Non-operating	3.0 <i>g</i> peak, 5–200 Hz, 0.4 decades/min
Shock	Operating and Non-Operating	1000 <i>g</i> @ 1.0 msec, one shock along each axis (x, y, and z) in each direction total of 2 per axis (+/-x, y, and z)

2.0 Product Description

The CloudSpeed Gen. II includes a NAND flash controller that provides a 6 Gbits/sec SATA interface to the host. Parallel access to multiple flash sites allows overlapped, multi-block access to rapidly complete data transfer requests. The controller continuously monitors drive temperature by polling an on-board thermal sensor, enabling notification to the host via a SMART trip in the event of an over-temperature condition. The backup power circuitry feature provides a holdup capacitor array to ensure data integrity during power fail scenarios.

2.1 Functional Block Diagram

Figure 1: CloudSpeed Gen. II Block Diagram

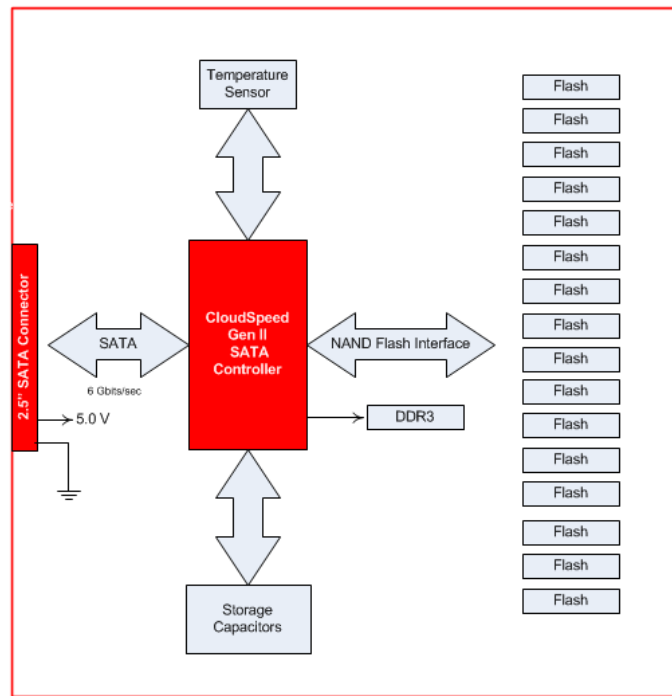

2.2 Flash Management

The CloudSpeed Gen. II supports the following techniques for enhanced flash management:

- **Static Wear Leveling:** This feature eliminates overstressing flash media by spreading the data writes across all flash physical address space, including logical areas that are not written by the user.
- **ECC:** The CloudSpeed Gen. II utilizes advanced two-level BCH code and a FRAME data recovery algorithm. The drive activates this second tier of error correction if the ECC engine is unable to correct the data located in failed NAND pages.
- **Bad-block Management:** This feature tracks all manufacturing and run-time bad blocks of flash media and replaces them with new ones from the spare pool.
- **Data Retention Management:** As flash is used over the life of the drive, data retention capability declines. The CloudSpeed Gen. II incorporates multiple data-retention management techniques to ensure the highest data reliability and integrity, even toward the end of drive life.
- **Minimal Write Amplification:** Write amplification is defined as the ratio of total data written to the flash compared to the total data written by the host. This ratio varies continually as a function of workload. CloudSpeed Gen. II controllers utilize write optimization, effective wear leveling, intelligent bad-block management, and efficient recycling to deliver an unprecedented, low write amplification factor. This translates directly to higher and more stable performance over a longer life.

2.3 Endurance

The CloudSpeed Gen. II provides the innovative FlashGuard technology feature to extract higher endurance from MLC flash. FlashGuard incorporates two important technology breakthroughs in the area of flash and SSD system management:

- Aggregated Flash Management
- Advanced Signal Processing

2.3.1 Aggregated Flash Management

SanDisk's Aggregated Flash Management technology prolongs the life of SSDs by treating all flash elements in the SSD as a system instead of as a collection of discrete elements. Aggregating the management of the flash over multiple pages within a block and over multiple blocks within the SSD reduces the limitations imposed at the page and block levels, thus extending the life of the drive.

FlashGuard treats each flash cell individually, thereby maximizing the effects of stronger flash elements (i.e., those that exhibit higher performance capability) while minimizing the effects of weaker elements. The capability of FlashGuard to distinguish between and take advantage of flash elements at the cellular level extends the endurance of the drive.

2.3.2 Advanced Signal Processing

The controller's Advanced Signal Processing technology periodically monitors the flash and collects detailed performance statistics. This information is used to dynamically adjust the flash operating parameters for maximum endurance from the drive throughout its operational life. To further extend the life of the drive, FlashGuard incorporates a proprietary enhanced error correction technology that corrects more data errors than is possible with standard schemes.

2.4 Temperature Throttling

The CloudSpeed Gen. II supports temperature throttling to guarantee the life of the drive. With this feature, the drive throttles the drive performance based on a pre-configured temperature level of 65 °C, which is measured by the drive thermal sensor. When the critical temperature (65 °C) is reached, the drive throttles write performance and increments the Lifetime Thermal Throttle Activations SMART attribute (ID 244) counter. Performance remains throttled until the temperature falls to 63°C or below.

NOTE:	The throttling level varies depending on the current workload.
--------------	--

2.5 Mean Time Between Failures (MTBF)

The MTBF statistic for the CloudSpeed Gen. II is calculated based on the MIL-HDBK-217 standard MTBF Values.

Table 4: MTBF Hours

	MTBF (Hours)
All	>2,000,000

2.6 Regulatory Standards Compliance

Table 5: Regulatory Agency Approvals

	Country/ Region	Compliance/Agency	Standard	Additional Information
Safety	USA	UL	UL 60950-1, Second Edition	---
	Canada	CSA	CSA C22.2 No. 60950-1-07, Second Edition	---
	Korea	EMI	KN22, KN24, CFR47	---
	Taiwan	EMI	CNS 13438	---
SATA	---	SATA-IO	SATA Revision 1.4 Interoperability Testing	---
RoHS	European Union	EU Directive 2011/65/EU (RoHS)	---	---
EMC	USA	FCC	FCC Part 15 Class B	FCC Declaration of Conformity
	Canada	Industry Canada	ICES-0030 Class B	IO Declaration of Conformity
	European Union	EU Directive 2004/108/EC (EMC)	EN 55022-2010 Class B	CE Declaration of Conformity
	Korea	KCC	KN22:2009 Class B KN24:2009	KCC Certificate
	Taiwan	BSMI	CNS13438 (2006)	BSMI Declaration of Conformity
	Australia	ACMA	AS/NZS CISPR22-2006, Class B	C-Tick Declaration of Conformity

3.0 Mechanical Specifications

3.1 Physical Specifications

Table 6: Physical Characteristics

	Value
Height (Mounted)	7.17 mm (Maximum)
Width	69.85 mm (Nominal)
Length	100.20 mm (Nominal)
Weight	63.00 g (Maximum)

3.2 Drive Mounting

Table 7: Measurements of Screws and Torque

	Value
Screw Thread Type	M3 x 0.5 metric
Maximum Applied Torque	4.0 lbf-inch

Figure 2: CloudSpeed Gen. II Drive Dimensions (in mm)

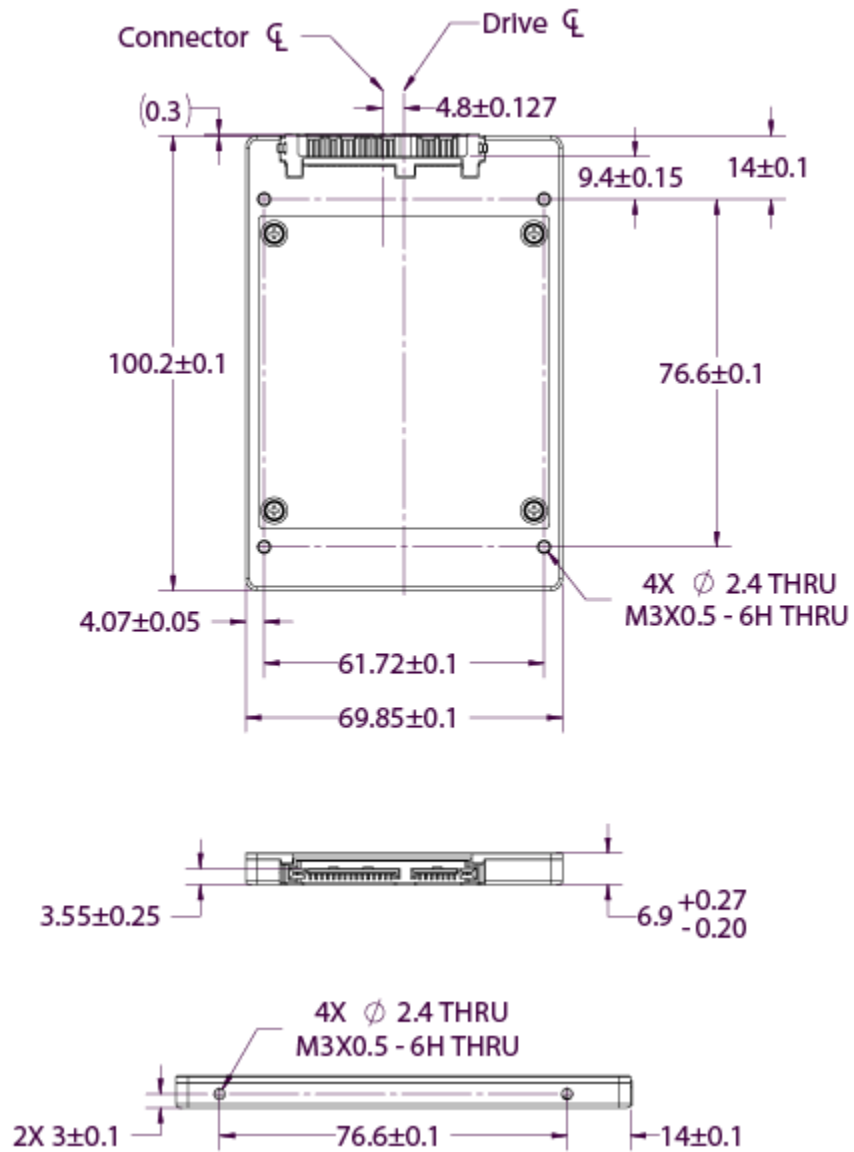

NOTE:	The warranty is voided if the label is removed.
--------------	---

4.0 Electrical Specifications

4.1 Electrical Interface

The CloudSpeed Gen. II includes a SATA 6 Gbits/sec interface (SATA 3 Gbits/sec and SATA 1.5 Gbits/sec compatible) that complies with SATA standard version 3.2.

4.1.1 CloudSpeed Interface Connector and Pinout Descriptions

The SATA connector on the CloudSpeed Gen. II includes a signal bay (S1 to S7) and a power bay (P1 to P15). The SATA connector can support both cabled and backplane plug-in connections. The connector complies with the Telcordia GR-78 standard (NEBS), meeting the minimum requirement of 30 μinches of gold over a nickel base of 50 μinches.

Figure 3: SATA connector for CloudSpeed Gen. II

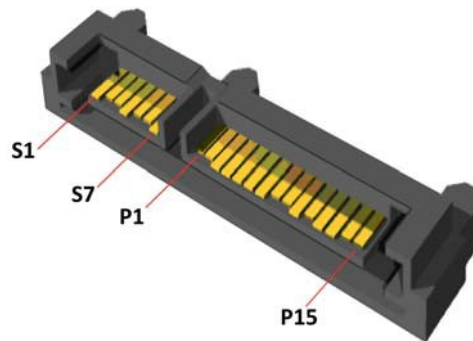

Table 8: Signal Pinout Description

	Signal Name	In/Out	Signal Description
S1	GND	N/A	2 nd mate
S2	Dev Rx+	In	Receive differential pair signal in +
S3	Dev Rx-	In	Receive differential pair signal in -
S4	GND	N/A	2 nd mate
S5	Dev Tx-	Out	Transmit differential signal out -
S6	Dev Tx+	Out	Transmit differential signal out +
S7	GND	N/A	2 nd mate

Table 9: Power Pinout Descriptions

Pin	Signal Name	In/Out	Signal Description
P1	V3.3	N/A	3.3 V power (not used)
P2	V3.3	N/A	3.3 V power (not used)
P3	V3.3	N/A	3.3 V power (not used)
P4	GND	In	1 st mate
P5	GND	In	2 nd mate
P6	GND	In	2 nd mate
P7	V5	In	5 V power, pre-charged, 2 nd mate
P8	V5	In	5 V power
P9	V5	In	5 V power
P10	GND	In	2 nd mate
P11	Reserved	In/Out	Activity indicator

Table 9: Power Pinout Descriptions (Continued)

Pin	Signal Name	In/Out	Signal Description
P12	GND	In	1 st mate
P13	V12	N/A	12 V power (not used)
P14	V12	N/A	12 V power (not used)
P15	V12	N/A	12 V power (not used)

4.2 Remote LED

In compliance with the SATA standard, pin P11 on the SATA 15-pin power connector supports a remote LED. Because the signal is not suitable for directly driving an LED, a circuit external to the device must first buffer the signal. When connected, the remote LED indicates activity. Refer to the SATA standard for more details.

4.3 Thermal Sensor

The CloudSpeed Gen. II contains a thermal sensor on the printed circuit board. The drive polls the sensor for temperature information every 60 seconds, and the drive stores the highest and lowest readings in the drive logs. This temperature represents the temperature of the NAND, not the drive case.

4.4 Power

4.4.1 DC Noise and Ripple

Noise is a random fluctuation in an electrical signal. Ripple is the small unwanted residual periodic variation of the direct current (DC) output of a power supply that has been derived from an alternating current (AC) source. This ripple is due to the incomplete suppression of the alternating waveform within the power supply.

Table 10: Noise and Ripple Summary

	Parameter	Ratings	Unit
V _{NOISE}	5 V noise and ripple (0 Hz to 80 MHz)	100	mVp-p

NOTE:	$I_{\text{NOISE}} + I_{\text{RIPPLE}} \leq 100 \text{ mA}$
--------------	--

4.4.2 DC Input Voltage

Table 11: DC Input Voltage Summary

	Parameter	Ratings	Unit
V _{IN}	5 V Supply Voltage	-5% / +10%	V

4.4.3 Hot Plug

The CloudSpeed Gen. II supports a hot plug feature. Maximum average inrush current when drive is hot-plugged is less than 900 mA, using a 200 µsec sampling window.

4.4.4 Power Consumption

Power is measured under the following conditions: $V_{IN} = 5.0\text{ V}$ and $T_{AMB} = 25\text{ }^{\circ}\text{C}$. Power measurements were taken on the highest capacity drive. Lower capacities will have lower drive power

Table 12: Power Consumption

	Description	Current (A) Typical ¹²	Current (A) Maximum ¹³	Power (W) Typical	Power (W) Maximum
Idle	Transient (Peak) ⁹	0.50	0.55	---	---
	Average ¹⁰	0.31	0.32	1.55	1.60
Startup ¹¹	Transient (Peak)	0.80	0.90	---	---
	Average	0.37	0.42	1.85	2.10
Sequential Read	Transient (Peak)	0.65	0.71	---	---
	Average	0.57	0.60	2.85	2.95
Sequential Write	Transient (Peak)	1.36	1.48	---	---
	Average	0.80	0.85	4.00	4.10

4.4.5 Absolute Maximum Ratings

Exposure to conditions beyond limits listed in the following table may result in damage to the product.

Table 13: Absolute Maximum Ratings

	Parameter	Ratings (Max)	Unit
V_{MAX}	High 5 V Supply Voltage	5.7	V
V_{MIN}	Low 5 V Supply Voltage	-0.3	V
T_{STG_L}	Low Storage Temperature	-40	$^{\circ}\text{C}$
T_{STG_H}	High Storage Temperature	85	$^{\circ}\text{C}$
T_{OP}	High Internal Operating Temperature	70	$^{\circ}\text{C}$

9. Transient power (peak) is mean power over any 200 μsec sampling window.

10. Average power is mean power over any 5 second sampling window.

11. Startup is measured from power on to ready for media access.

12. Typical is population mean.

13. Maximum values represent mean of population + 3 sigma.

5.0 Software Specifications

5.1 Enterprise SATA Implementation

SSD firmware implements all features required of enterprise drives.

Table 14: Supported ATA Commands

Command Name	Op Code (Hex)	Command Set (Category)
Check Power Mode*	E5	Power Management
Data Set Management	06	General
Download Microcode	92	General
Execute Drive Diagnostic	90	General
Flush Cache	E7	General
Flush Cache Extended (See Set Features Subcommands on page 20.)	EA	48 Bit Address
Identify Device	EC	General
Idle*	E3	Power Management
Idle Immediate*	E1	Power Management
NOP	00	General
Read Buffer PIO	E4	General
Read DMA	C8	General
Read DMA Extended	25	48 Bit Address
Read DMA w/o Retries	C9	General
Read FPDMAQ	60	NCQ
Read Log	2F	GPL
Read Log DMA Extension	47	48 Bit Address
Read Long w/o Retries	23	General
Read Multiple – PIO Multiple Read/Write	C4	General
Read Multiple Ext – PIO Multiple Read/Write	29	48 Bit Address
Read Native Max Address	F8	HPA
Read Native Max Address Extended	27	48 Bit Address
Read Sectors – PIO	20	General
Read Sectors Extended – PIO	24	48 Bit Address
Read Sectors – PIO	21	General
Read Verify Sectors	40	General
Read Verify Sectors Extended – PIO	42	48 Bit Address
Recalibrate	10	General
Sanitize Device	B4	General
Security Erase Prepare	F3	Security
Security Erase Unit	F4	Security
Security Freeze Lock	F5	Security
Security Disable Password	F6	Security
Security Set Password	F1	Security
Security Unlock	F2	Security
Seek	70	General
Send FPDMA Queued	65	NCQ

Table 14: Supported ATA Commands(Continued)

Command Name	Op Code (Hex)	Command Set (Category)
Set Features (See Set Features Subcommands on page 20.)	EF	General
Set Max Address	F9	HPA
Set Max Address Extended	39	48 Bit Address
Set Multiple Count - PIO Multiple Read/Write	C6	General
Sleep*	E6	Power Management
SMART Operations	B0	SMART
Standby*	E2	Power Management
Standby Immediate*	E0	Power Management
Write Buffer DMA	E8	General
Write DMA	CA	General
Write DMA Extended	35	48 Bit Address
Write DMA w/o Retries	CB	General
Write FPDMAQ	61	NCQ
Write Log	3F	GPL
Write Log DMA Extended	57	48 Bit Address
Write Long	32	General
Write Long w/o Retries	33	General
Write Multiple PIO Multiple Read/Write	C5	General
Write Multiple Extended - PIO Multiple Read/Write	39	48 Bit Address
Write Sectors	30	General
Write Sectors w/o Retries	31	General
Write Sectors Extended - PIO	34	48 Bit Address
Write Uncorrectable Extended	45	General

* The SSD accepts these commands and returns a good status, but does not execute the commands.

5.2 Device Identification Information

Table 15: Identify Device Information

	Data	Description
0	5A0Ch	General configuration; bit-significant information
59	0xF500	Sanitize Information
76	0x950E	Serial ATA capabilities
77	0x0066	Reserved for future Serial ATA capabilities
81	0x0039	Minor version number
85	0x7069	Command set/feature supported
106	0x6003	Physical/Logical sector size
119	0x405C	Commands and feature sets supported
120	0x401C	Commands and feature sets supported
206	0x003D	SCT command transport
209	0x4000	Alignment of logical blocks within a larger physical block
255	0x04A5	Integrity Word

5.3 Set Features Subcommands

Table 16: Set Features Subcommands

	Decimal	Description
02	2	Enable Write Cache
10	16	Enable Use of Serial ATA Features
55	85	Disable Read Look Ahead
82	130	Disable Write Cache
90	144	Disable Use of Serial ATA Features
AA	170	Enable Read Look Ahead

5.4 Supported SMART Operations

Self-Monitoring Analysis and Reporting Technology (SMART) attributes provide diagnostic information regarding drive operation. SMART alerts the host to potential drive problems, allowing system operators to assess the situation and back up data prior to an operational failure.

With SMART, the CloudSpeed Gen. II continually monitors a number of key internal operating parameters to identify performance changes that could be a sign of impending drive failure. When the drive detects such a condition, the drive alerts the host system of a reduction in reliability or performance.

Table 17: Supported SMART Attributes

Attr ID (Decimal)	Threshold (Decimal)	Name	Values	Indicates:
5	N/A	Lifetime Reallocated Erase Block Count		The total number of erase blocks added to the defect list after manufacturing. Normalized Value: Set to 64h Worst: Set to 64h Raw Data: Range between 0 and 0xFFFFFFFF
9	N/A	Lifetime Power on Hours (POH)	1-100 (Normalized)	The total number of hours the drive has had power applied to it since the date of manufacture (DOM). The value is updated hourly. The attribute tracks the number of seconds since the last hour update. Normalized Value: Range is 100d - 1. For every tenth of a year, this field will decrement by one. Worst: Same as normalized value Raw Data: [5:8]: Number of hours since manufacture [9:11]: Number of seconds since the last whole hour
13	1	Lifetime UECC Count		It is from the variable <code>recovery_fail_count</code> , which is a count of pages that saw a recover failure. The counter increases if the drive sees a read error that is unrecoverable with FRAME, for example, the data was lost. Normalized Value: Set to a fixed value of 64h Worst: Set to a fixed value of 64h Raw Data: Range between 0 and 0xFFFFFFFF
32	N/A	Lifetime Write Amplification Factor		Write amplification is supported as a rate which means data needs to be flowing for the value to be displayed. The variables <code>flash_lp_writes</code> and <code>host_lp_writes</code> maintained by FTL are used to create a lifetime write amplification factor. Normalized Value: Set to a fixed value of 64h Worst: Set to 64h Raw Data: The value should be around C8h, but is expected to be less than 1F4h
33	N/A	Trailing Hour Write Amplification Factor		The trailing hour write amplification is updated once an hour using the variables <code>flash_lp_writes</code> and <code>host_lp_writes</code> maintained by FTL. Normalized Value: Set to a fixed value of 64h Worst: Set to a fixed value of 64h Raw Data: The value should be around C8h, but is expected to be less than 1F4h
170	N/A	Reserve Erase Block Count		This is the number of reserved erase blocks remaining. Normalized Value: Set to a fixed value of 64h Worst: Set to a fixed value of 64h Raw Data: The value ranges from 26,956 to 0 for 1,920 GBytes, 12,478 to 0 for 960 GBytes, and 6,739 to 0 for 480 GBytes.

Table 17: Supported SMART Attributes (Continued)

Attr ID (Decimal)	Threshold (Decimal)	Name	Values	Indicates:
175	N/A	Lifetime Die Failure Count		Die failures are not tracked and they are not recognized. The drive sees a die failure as a number of block failures. This is supported in the sense that field exists in the SMART read data, but the raw data bytes are set to a fixed value of zero. Normalized Value: Set to a fixed value of 64h Worst: Set to a fixed value of 64h Raw Data: Set to a fixed value of zero
183	N/A	Lifetime Link Rate Downgrade Count		At power-up, the drive detects the SATA link rate. If, after a COMRESET, the link rate drops the counter is incremented by one. Normalized Value: Set to a fixed value of 64h Worst: Set to a fixed value of 64h Raw Data: Set to a fixed value of lifetime_sata_link_downgrades. Value will start at zero and count up.
191	N/A	Clean Lifetime Shutdown Count on Power Loss		There can only be clean power downs. FTL maintains a count of power downs. Normalized Value: Set to a fixed value of 64h Worst: Set to a fixed value of 64h Raw Data: Starts at zero (or a low value) and increases by one for each power down
192	N/A	Unclean Lifetime Shutdown Count on Power Loss	0-100 (Normalized)	There are no unclean power downs. This is set to zero. Normalized Value: Set to a fixed value of 64h Worst: Set to a fixed value of 64h Raw Usage: Fixed value of zero
194	70	Current Temperature, Lifetime Maximum Temperature		Temperature is tracked and the maximum temperature is maintained. The threshold is 70 °C Normalize Value: 100 – (temperature) Worst: 100 (highest temperature) Raw Data: [5:6]: Current temperature (°C) [7]: Lowest temperature recorded over the lifetime of the drive (°C) [8]: Highest temperature recorded over the lifetime of the drive (°C)
196	N/A	Lifetime Retired Block Count		This is the total number of erase blocks added to the defect list after manufacturing. Normalized Value: Set to 64h Worst: Set to 64h Raw Data: Range between 0 and 0xFFFFFFFF
211	N/A	Lifetime Read Disturb Reallocation Events		This is supported using FTL variable read_disturb_recycled_sbs_nv. Normalize Value: Set to a fixed value of 64h Worst: Set to a fixed value of 64h Raw Data: Range between 0 and 0xFFFFFFFF. This starts at zero and increases.
233	N/A	Lifetime NAND Writes		The number of lifetime NAND writes since the date of manufacture. The count increments in units of 64 GBytes. Normalize Value: Set to a fixed value of 64h Worst: Set to a fixed value of 64h Raw Data: Set to a value of zero
235	N/A	Capacitor Health		The drive is not able to measure capacitor health. This value is fixed at zero. Normalize Value: Set to a fixed value of 64h Worst: Set to a fixed value of 64h Raw Data: Set to a value of zero

Table 17: Supported SMART Attributes (Continued)

Attr ID (Decimal)	Threshold (Decimal)	Name	Values	Indicates:
241	N/A	Lifetime User Writes		The total number of data bytes written to the drive since date of manufacture. The count increments in units of 64 GBytes. Normalized Value: Set to a fixed value of 64h Worst: Set to a fixed value of 64h Raw Data: Range between 0 and 0xFFFFFFFF
242	N/A	Lifetime User Reads		The total number of data bytes read from the drive since date of manufacture. The count increments in units of 64 GBytes. Normalized Value: Set to a fixed value of 64h Worst: Set to a fixed value of 64h Raw Data: Range between 0 and 0xFFFFFFFF
244	N/A	Lifetime Thermal Throttle Activations		The variable increases each time thermal throttling is activated. Normalized Value: Set to a fixed value of 64h Worst: Set to a fixed value of 64h Raw Data: Range between 0 and 0xFFFFFFFF
245	2%	Percentage of Drive Life Remaining		The percentage of drive life remaining. Normalized Value: Data range is 100 to 0 Worst: 100-0 Raw Data: Data is 100-0 (percent completely used)
253	1	SPI Tests Remaining		Header sections of SPI firmware areas are read and checksum computed. If the checksum is not correct, the SPI is corrupt and a SMART trip will occur. Normalized Value: 100 or 0 Worst: 100 or 0 Raw Data: Normal value is 0. A non-zero value indicates an error condition.

6.0 Warranty and Part Numbers

6.1 Warranty

The CloudSpeed Gen. II is designed for high performance computing environments. The CloudSpeed Gen. II is warranted per product for 5 years for defects in material and workmanship and for its rated endurance specified in DWPD. The drive will make no attempt to limit application performance to meet the DWPD constraint. Configurable SMART warnings are provided to help the application designer manage drive wear-out, including the percentage of drive life used, lifetime remaining, and write amplification SMART attributes.

6.2 Part Numbering Information

Table 18: Part Numbering Information

	Product	Drive Capacity	LBAs
SDLF1DAR-480G-1HA1	CloudSpeed Eco Gen. II	480 GBytes	937,703,088
SDLF1DAR-960G-1HA1	CloudSpeed Eco Gen. II	960 GBytes	1,875,385,008
SDLF1CRR-019T-1HA1	CloudSpeed Eco Gen. II	1,920 GBytes	3,750,748,848
SDLF1DAM-400G-1HA1	CloudSpeed Ultra Gen. II	400 GBytes	781,422,768
SDLF1DAM-800G-1HA1	CloudSpeed Ultra Gen. II	800 GBytes	1,562,824,368
SDLF1CRM-016T-1HA1	CloudSpeed Ultra Gen. II	1,600 GBytes	3,125,627,568