

## HARSH ENVIRONMENT IP66 / IP68 SHIELDED MINI-CON-X® CONNECTOR

### Features and Benefits

- Protects circuits from EMI & RF interference
- Rugged machined metal housing and construction
- Field installable
- Scoop-proof connector design
- Same panel cutout as MINI-CON-X®
- Also available overmolded

### Applications

- Conveyor Equipment
- Machine Tools
- Spot Welders
- Automated Assembly
- Food Processing Equipment
- Packaging & Material Handling Equipment

### Product Specifications

#### Materials

##### **Panel Shell, Cable Housing & Coupling Nuts:**

Nickel plated copper alloy

##### **All Connector Inserts:** Engineered Polyester Resin

##### **Contacts:** Gold plated copper alloy with nickel underplate

##### **Backshell & Strap:** G.F. Nylon

##### **O-Rings:** Neoprene

##### **Grommet:** Santoprene®

##### **Screws:** Stainless Steel

#### Mechanical

##### **Shock:** Method 213, Mil-Std 202

##### **Vibration:** Method 201, Mil-Std 202

##### **Life:** 400 insertion/withdrawal cycles

#### Electrical

##### **Voltage Rating:** Tested at 600 VRMS

##### **Insulation Resistance:** Method 302, Mil-Std 202

##### **Contact Resistance:** Method 307, Mil-Std 202

##### **Current Ratings:**

13A: 1 - 6, #16 contacts with 16 AWG Wire

7.5A: 1 - 3, #20 contacts with 20 AWG Wire

5.6A: 4 - 8, #20 contacts with 20 AWG Wire

#### Environmental

##### **Operating Temperature Limits:** -40°C (-40°F) to +85°C (+185°F)

##### **Temperature Rise:** UL 1054

##### **Thermal Shock:** Method 107, Mil-Std 202

##### **Moisture/Salt Spray:** Method 106F / 101 Mil-Std 202

##### **Product Ratings:** IP66 / IP68 (when mated), RoHS Compliant



Mated Cable End



Cable End



Epoxy Sealed  
Panel Mount

# HARSH ENVIRONMENT IP66 / IP68 SHIELDED MINI-CON-X<sup>®</sup> CONNECTOR

## Cable End

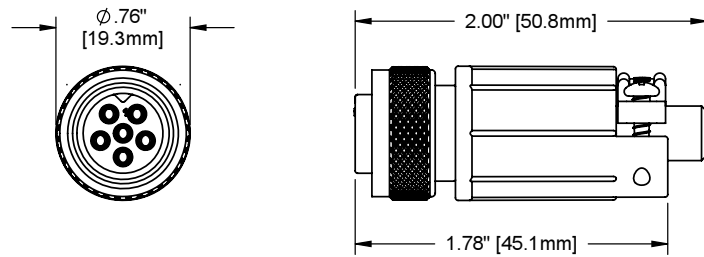

## Panel Mount

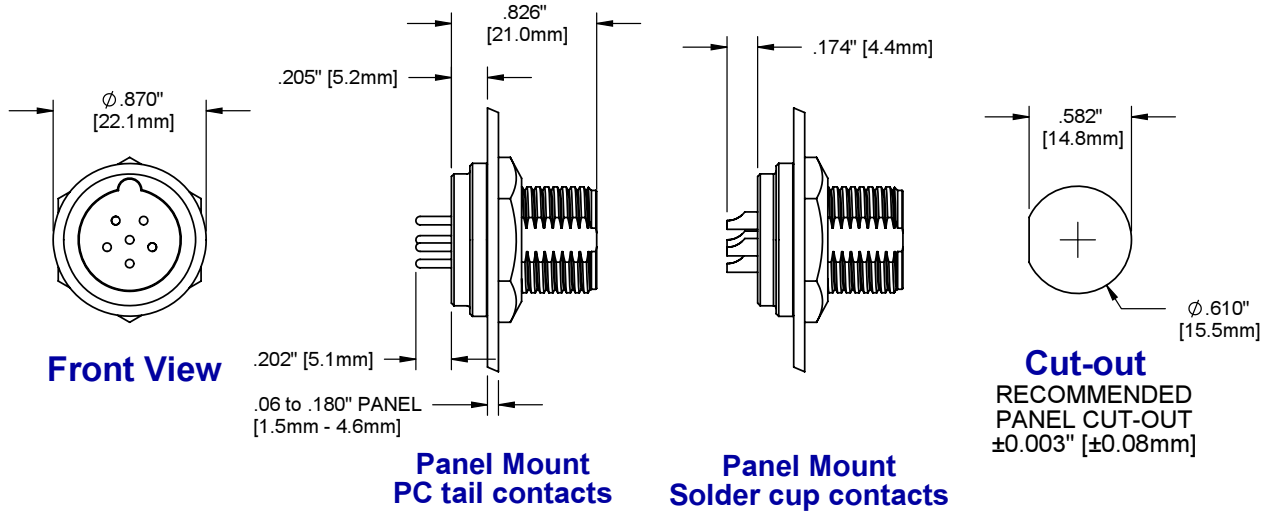

## Contact Arrangements (Wiring View of Cable End)

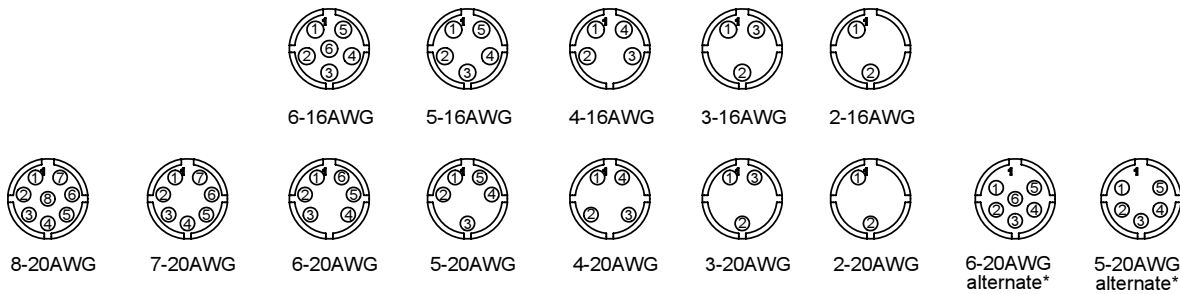

\* Consult Factory

## Code Logic

