

4

3

2

1

THIS DRAWING IS UNPUBLISHED. RELEASED FOR PUBLICATION .19 .  
 © COPYRIGHT 19 BY AMP INCORPORATED. ALL RIGHTS RESERVED.

LOC	DIST	REVISIONS			
P	LTR	DESCRIPTION	DATE	DWN	APVD
AF	50	C	REV PER ECR 06-001331	21JUL06	JR PD

- 1 CONTINUOUS STRIP ON REELS.
- 2 MATING TAB THK  $0.813 \pm 0.025$   $[\cdot 032 \pm \cdot 001]$ .
- 3 WIRE SIZE  $[\#14 - \#10]$  AWG.
- 4 INSUL RANGE IS 3.81-5.08  $[\cdot 150 - \cdot 200]$  DIA.

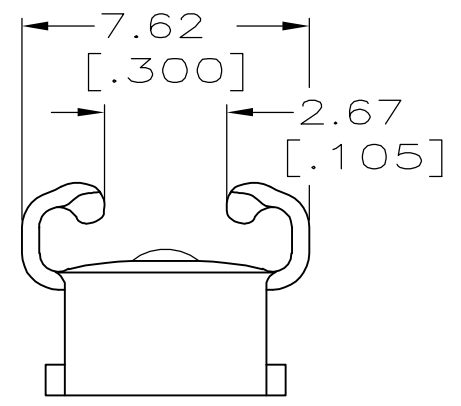
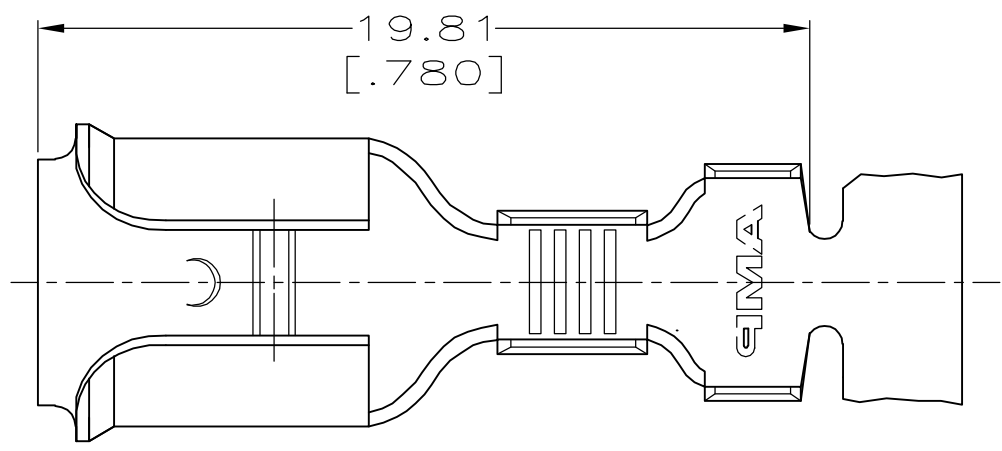

VIEW A-A

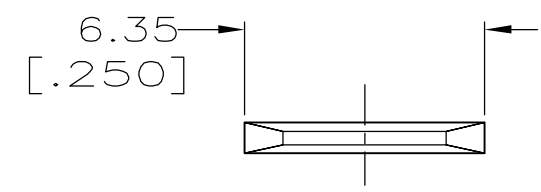

VIEW D-D

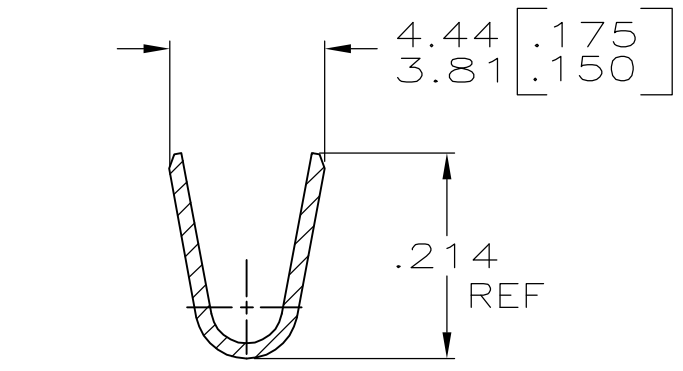
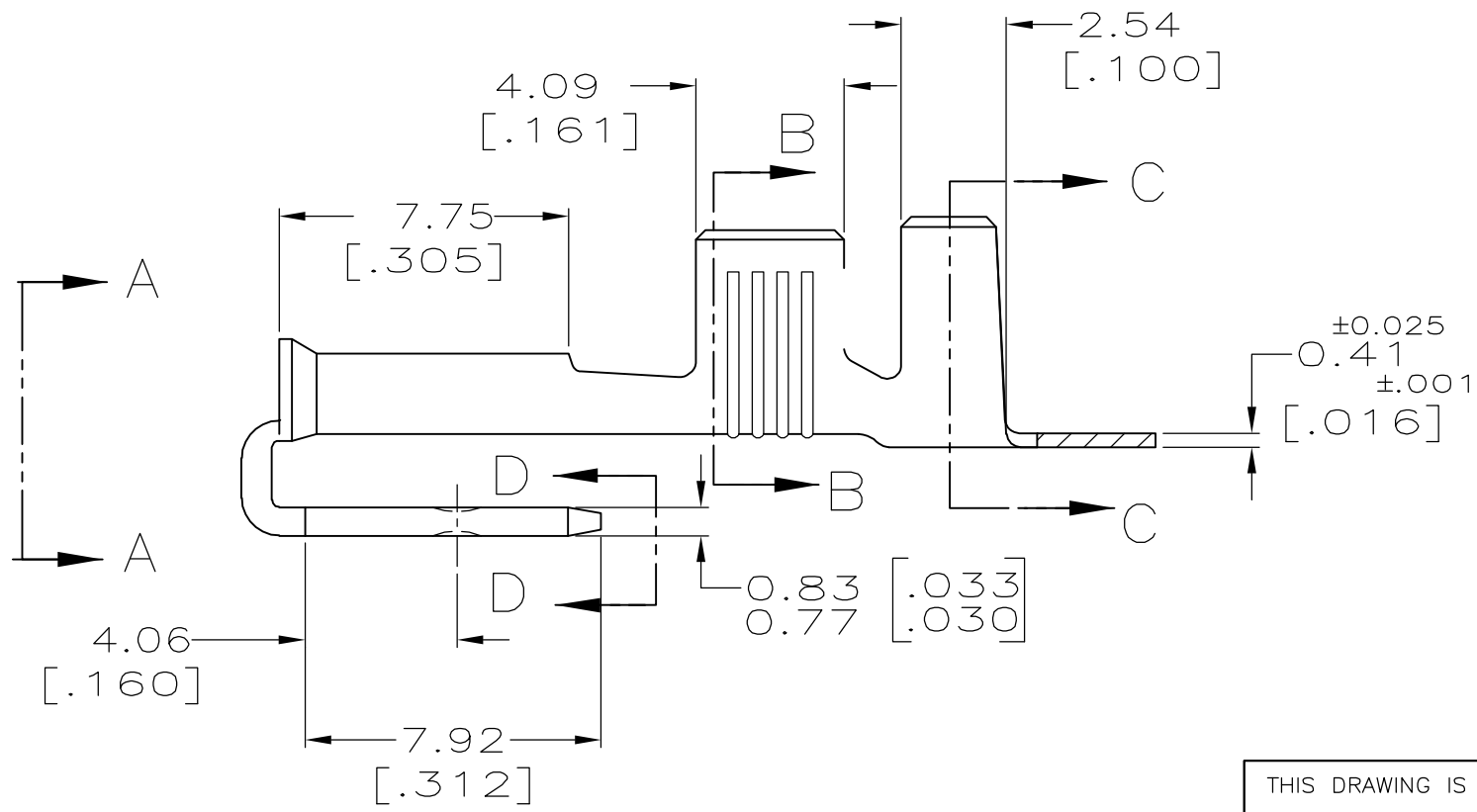

SECTION B-B

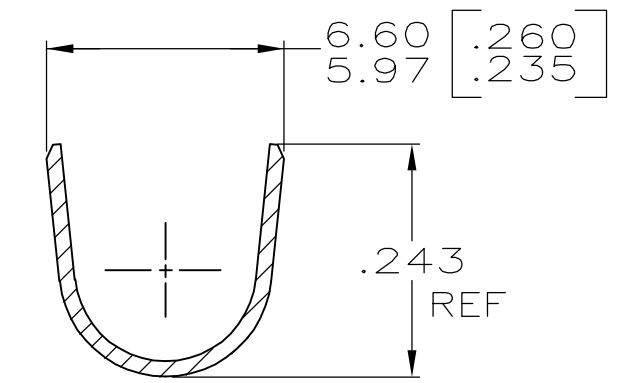

SECTION C-C

1217043-1  
 PART NO.

THIS DRAWING IS A CONTROLLED DOCUMENT.		DWN	JR RUTH	12/18/97	<b>AMP</b> AMP Incorporated Harrisburg, PA 17105-3608											
DIMENSIONS: MM [INCHES]		CHK	MS FEHER	12/18/97												
TOLERANCES UNLESS OTHERWISE SPECIFIED:		APVD	P DESANTIS	12/18/97												
<table border="0"> <tr><td>0 PLC</td><td>±-</td></tr> <tr><td>1 PLC</td><td>±-</td></tr> <tr><td>2 PLC</td><td>±0.25 [.010]</td></tr> <tr><td>3 PLC</td><td>±-</td></tr> <tr><td>4 PLC</td><td>±-</td></tr> <tr><td>ANGLES</td><td>±-</td></tr> </table>		0 PLC	±-	1 PLC		±-	2 PLC	±0.25 [.010]	3 PLC	±-	4 PLC	±-	ANGLES	±-	PRODUCT SPEC	
0 PLC	±-															
1 PLC	±-															
2 PLC	±0.25 [.010]															
3 PLC	±-															
4 PLC	±-															
ANGLES	±-															
MATERIAL H04 BRASS		FINISH 0.002032 [.000080] MIN TIN		APPLICATION SPEC												
		WEIGHT -		SIZE												
		CUSTOMER DRAWING		A3 00779 C- 1217043												
		SCALE 5:1		SHEET 1 OF 1												
		RESTRICTED TO -		REV C												