

THIS DRAWING IS UNPUBLISHED. RELEASED FOR PUBLICATION AUG. 2006.

© COPYRIGHT BY TYCO ELECTRONICS CORPORATION. ALL RIGHTS RESERVED.

LOC		DIST		REVISIONS			
P	LTR	DESCRIPTION		DATE	DWN	APVD	
B1		REVISED (ECR-13-010816)		08JUL13	JL	WK	

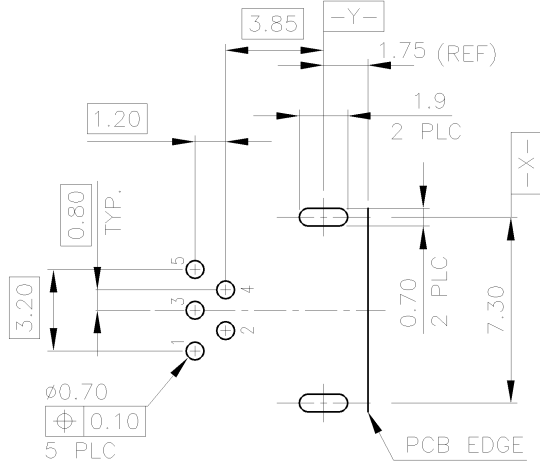
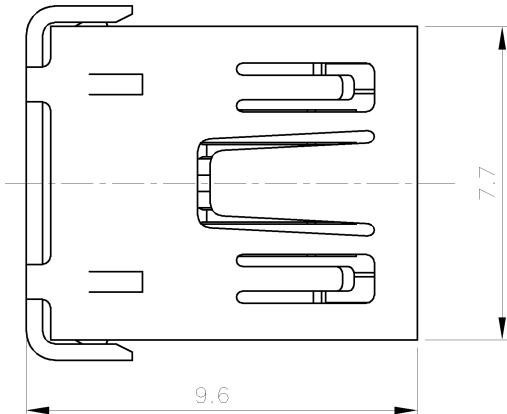
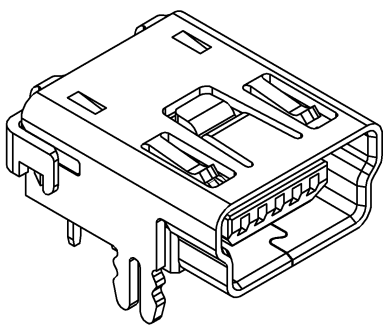

RECOMMENDED PCB LAYOUT (THICKNESS: 1.6MM)
 (DIMENSION TOLERANCE: 1 PLC: ±0.1 2PLC: ±0.05)

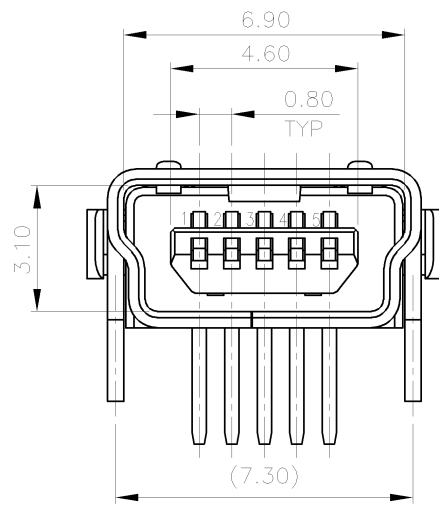
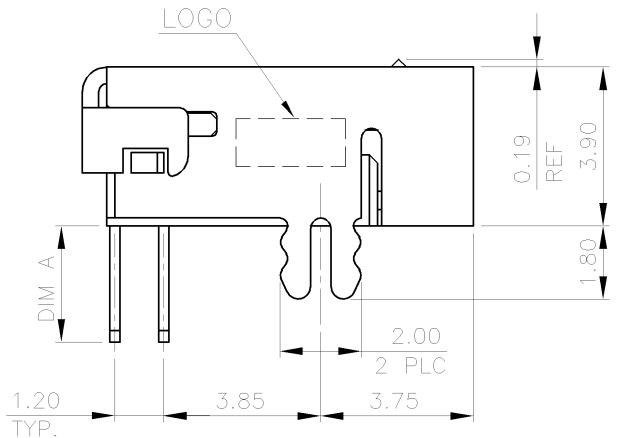
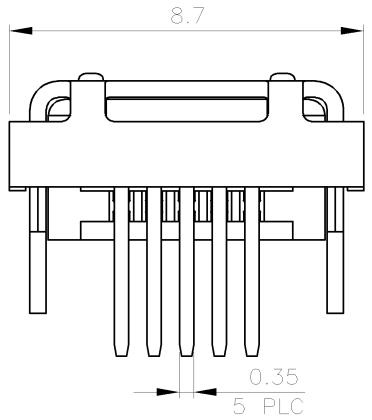

3.25	③	PBT	1-1734510-1
2.85	④	PA9T	1734510-2
2.85	③	PBT	1734510-1
DIM A	SOLERING PROCESS	HOUSING MATERIAL	PART NUMBER

NOTE:
 1. MATERIAL:
 HOUSING: (SEE TABLE) WITH 30% GF, UL 94V-0, COLOR BLACK.
 CONTACT: PHOSPHOR BRONZE, THICKNESS: 0.25mm.
 SHIELD: PHOSPHOR BRONZE, THICKNESS: 0.40mm.
 2. FINISH:
 CONTACT: GOLD FLASH OVER
 0.762um [30u"] MIN. PALLADIUM-NICKEL PLATED ON CONTACT AREA,
 2.54um [100u"] MIN. MATTE TIN PLATED ON SOLDER TAILS,
 1.27um [50u"] MIN. NICKEL UNDERPLATED ALL OVER.
 SHIELD: 5.08um [200u"] MIN. MATTE TIN OVER 2.54um [100u"] MIN. Cu.
 UNDERPLATED ALL OVER.
 ③ WAVE SOLDER CAPABLE TO 240°C. PER TE SPEC 109-202, CONDITION A.
 ④ WAVE SOLDER CAPABLE TO 265°C PER TE SPEC 109-202, CONDITION B.

THIS DRAWING IS A CONTROLLED DOCUMENT.		DWN S. CHIEN 20JAN2009	TE Connectivity	
DIMENSIONS: MM		CHK S. CHIEN 20JAN2009		
TOLERANCES UNLESS OTHERWISE SPECIFIED:		APVD W. KODAMA 20JAN2009	NAME	
		PRODUCT SPEC 108-57062	MINI USB CONN., RCPT R/A, DIP, B TYPE	
MATERIAL SEE NOTE		QUALIFICATION TEST REPORT 501-57070	SIZE A3	CAGE CODE 00779
FINISH SEE NOTE		WEIGHT 0.62 GRAMS	DRAWING NO C-1734510	RESTRICTED TO
		CUSTOMER DRAWING	SCALE	SHEET 1 of 2
				REV B1

LOC DW DIST

REVISIONS

P	LTR	DESCRIPTION	DATE	DWN	APVD
		SEE SHEET 1.			

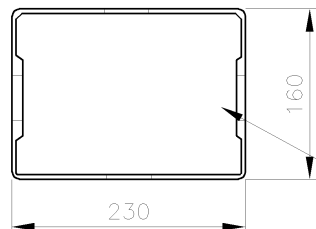

TARY

TOTAL: 95 PCS.
NET WEIGHT: 3.50 KGS.

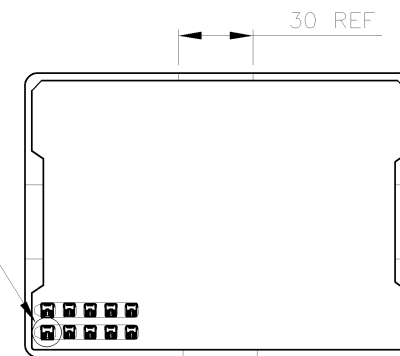

DETAIL A

HEIGHT : 8mm

PVC

PAPER BOARD

PVC

CARTON

TOTAL: 4370 PCS.
GROSS WEIGHT: 6.20 KGS.

DETAIL A

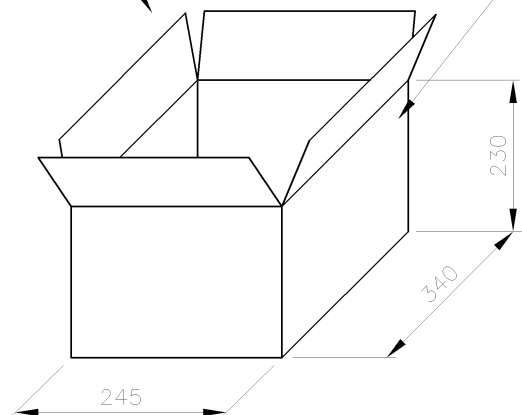

THIS DRAWING IS A CONTROLLED DOCUMENT.

DIMENSIONS:
MM

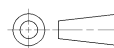

TOLERANCES UNLESS OTHERWISE SPECIFIED:	
0 PLC	± .
1 PLC	± .
2 PLC	± .
3 PLC	± .
4 PLC	± .
ANGLES	± .

MATERIAL

FINISH

DWN	
CHK	
APVD	
PRODUCT SPEC	
APPLICATION SPEC	
WEIGHT	



NAME
MINI USB CONN., RCPT R/A, DIP, B TYPE

SIZE	CAGE CODE	DRAWING NO	RESTRICTED TO
A3	00779	C=1734510	

CUSTOMER DRAWING

SCALE SHEET 2 of 2 REV B1