

THIS DRAWING IS UNPUBLISHED. RELEASED FOR PUBLICATION
 © COPYRIGHT 1963 BY TYCO ELECTRONICS CORPORATION. ALL RIGHTS RESERVED.

LOC	DIST	REVISIONS					
AF	50	P	LTR	DESCRIPTION	DATE	DWN	APVD
			N1	REV PER ECR 06-010783	09MAY06	JR	PD

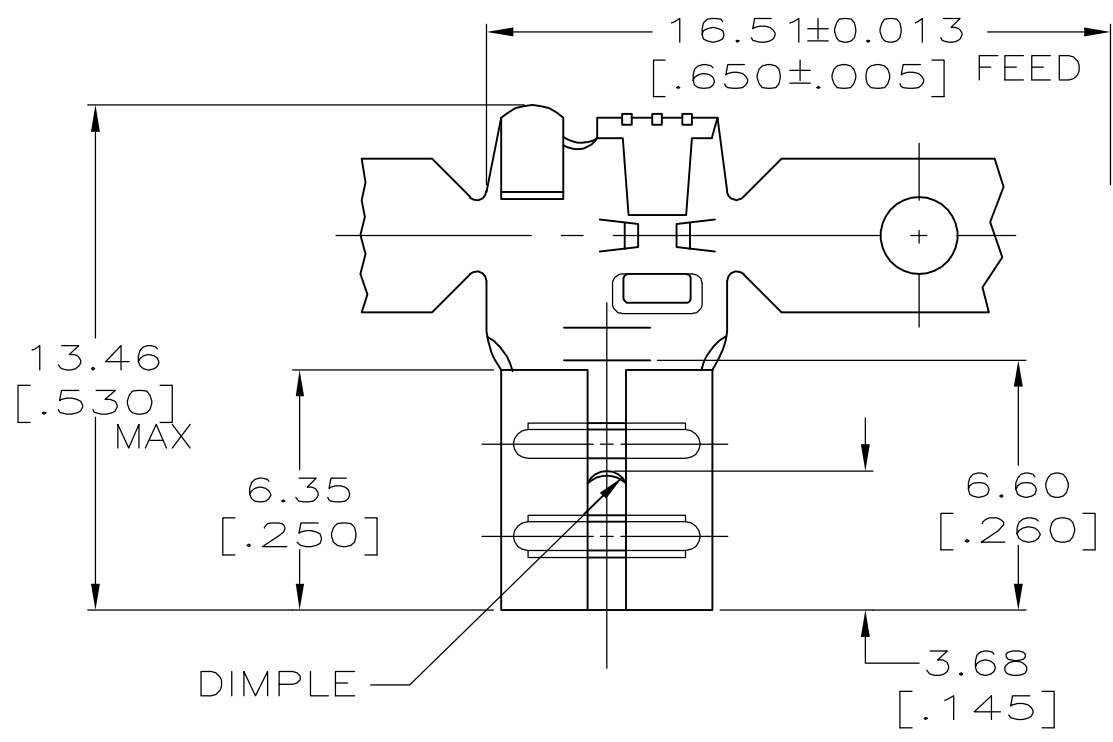

- 1 CONTINUOUS STRIP ON REELS.
- 2 WIRE SIZE IS [#20-#14] AWG.
- 3 INSULATION RANGE TO BE 2.79-4.32 [.110-.170] DIA.
- 4 MATING TAB THK TO BE 0.813 ± 0.025 [.032 ± 0.001].

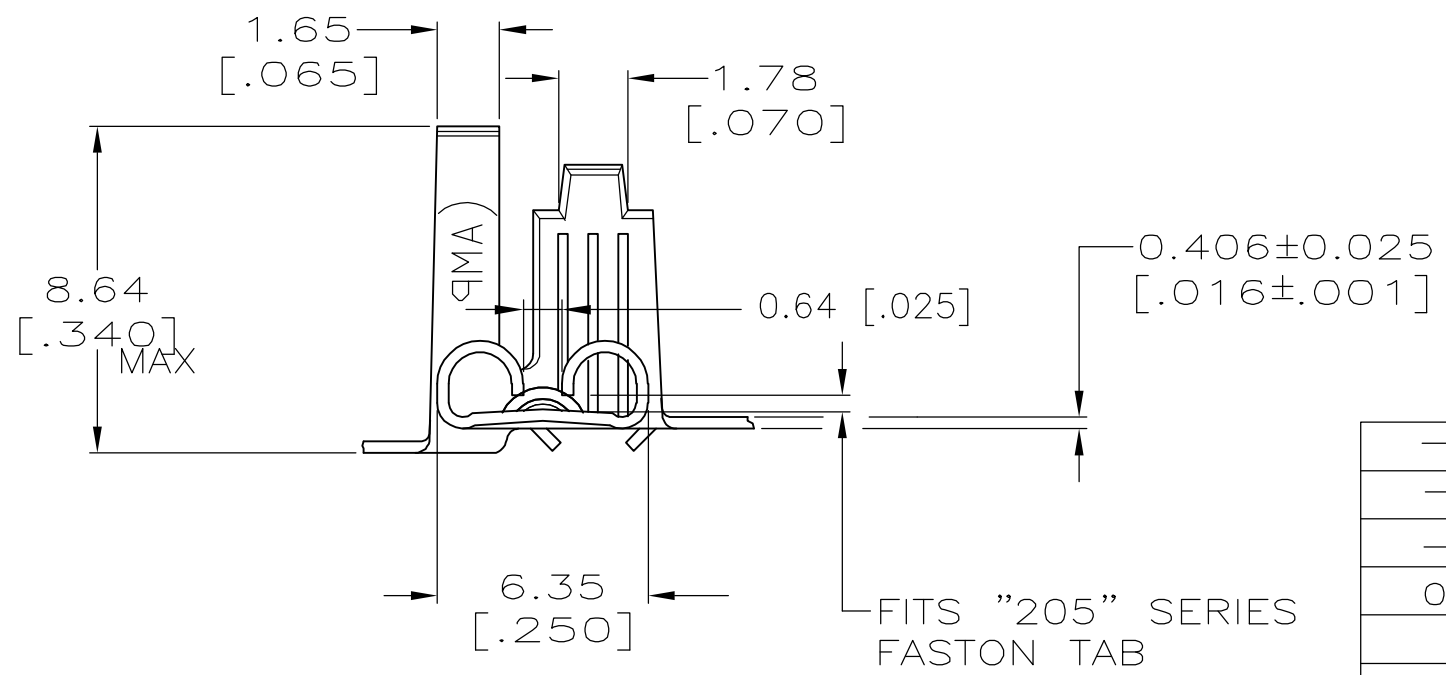

-	T3 PHOS BRONZE	42234-5
-	-	-
-	-	-
0.002032 [.000080] MIN TIN	H04 BRASS	42234-2
-	H04 BRASS	42234-1
FINISH	MATERIAL	PART NO

THIS DRAWING IS A CONTROLLED DOCUMENT.		DWN M.S. FEHER 25NOV2003	Tyco Electronics Corporation Harrisburg, PA 17105-3608	
DIMENSIONS: mm	TOLERANCES UNLESS OTHERWISE SPECIFIED:	CHK P DESANTIS 25NOV2003	NAME RECEPTACLE, FASTON, FLAG, 5.21 [.205] SERIES	
	0 PLC ± -	APVD P DESANTIS 25NOV2003	PRODUCT SPEC	
	1 PLC ± -		APPLICATION SPEC	
	2 PLC ± 0.25 [.010]		114-2078	
	3 PLC ± -		SIZE	CAGE CODE
	4 PLC ± -		A3	00779
	ANGLES ± -		DRAWING NO	RESTRICTED TO
MATERIAL SEE TABLE	FINISH SEE TABLE	WEIGHT -	C=42234	-
CUSTOMER DRAWING			SCALE 5:1	SHEET 1 OF 1
			REV N1	