

THIS DRAWING IS UNPUBLISHED. RELEASED FOR PUBLICATION
 © COPYRIGHT - By - ALL RIGHTS RESERVED.

LOC	DIST	REVISIONS					
FT	0	P	LTR	DESCRIPTION	DATE	DWN	APVD
		AU1		REVISED PER ECO-11-004587	11MAR11	RK	HMR

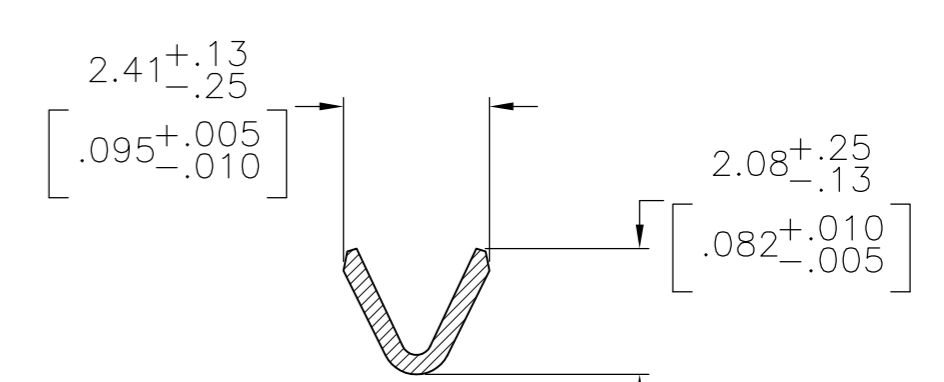
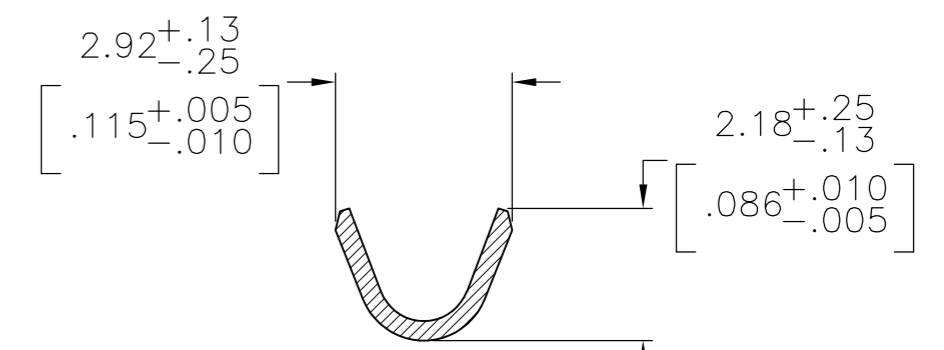
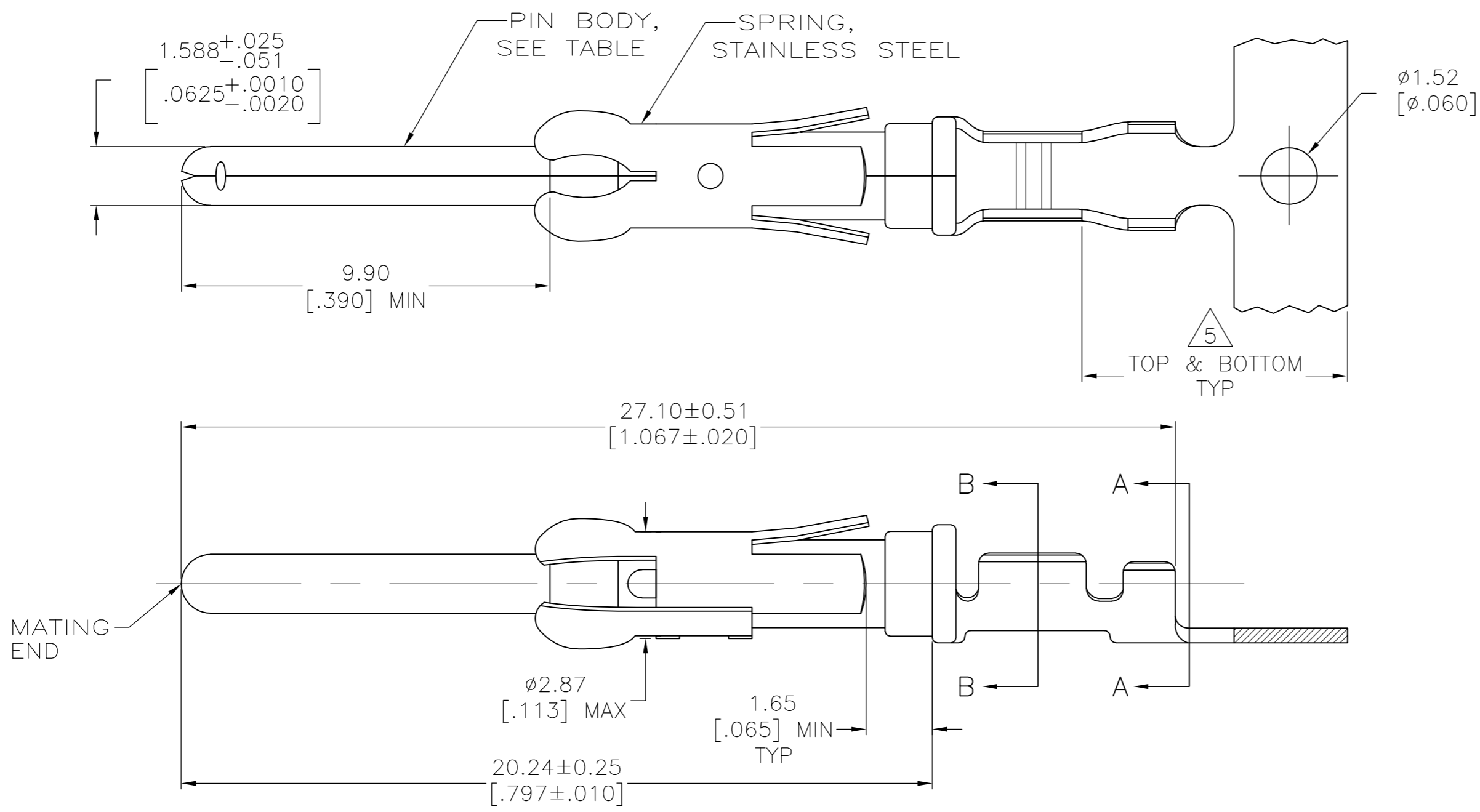

- 1 REVERSE REELED FOR MINI-APPLICATOR.
- 2 $0.76\mu\text{m}$ [$.000030$] MIN PRECIOUS METAL PLATE ON MATING END FOR A LENGTH OF 5.08 [$.200$] MIN OVER $1.27\mu\text{m}$ [$.000050$] MIN NICKEL. GOLD FLASH ALL OVER. CONFORMS TO THE REQUIREMENTS OF TE CONNECTIVITY PRODUCT SPEC 108-10042, BASED ON EIA/ECA-364-1000.01 (CONTROLLED ENVIRONMENT APPLICATIONS),
- 3 $0.76\mu\text{m}$ [$.000030$] MIN PRECIOUS METAL PLATE ON MATING END FOR A LENGTH OF 5.08 [$.200$] MIN WITH A UNIFORM GRADIENT TO $0.25\mu\text{m}$ [$.000010$] MIN ON REMAINDER, OVER $1.27\mu\text{m}$ [$.000050$] MIN NICKEL PLATE. GOLD FLASH ALL OVER. CONFORMS TO THE REQUIREMENTS OF TE CONNECTIVITY PRODUCT SPEC 108-10042, BASED ON EIA/ECA-364-1000.01 (CONTROLLED ENVIRONMENT APPLICATIONS).
- 4 $0.38\mu\text{m}$ [$.000015$] MIN GOLD PER MIL-G-45204 ON MATING END FOR A LENGTH OF 5.08 [$.200$] MIN WITH GOLD FLASH ON THE REMAINDER OVER $1.27\mu\text{m}$ [$.000050$] MIN NICKEL PER QQ-N-290.
- 5 GOLD PLATING NEED NOT APPEAR IN THIS AREA.
- 6 $1.27\mu\text{m}$ [$.000050$] MIN GOLD PER MIL-G-45204 ON MATING END FOR A LENGTH OF 5.08 [$.200$] MIN WITH GOLD FLASH ON THE REMAINDER OVER $1.90\mu\text{m}$ [$.000075$] MIN NICKEL PER QQ-N-290.
- 7 $1.27\mu\text{m}$ [$.000050$] MIN TIN-LEAD PER MIL-T-10727 OVER $1.27\mu\text{m}$ [$.000050$] MIN NICKEL PER QQ-N-290.
- 8 WIRE RANGE 24-20 AWG.
- 9 INSULATION RANGE 1.02 [$.040$]- 2.03 [$.080$] DIA.
- 10 $0.38\mu\text{m}$ [$.000015$] MIN GOLD PER MIL-G-45204 ON MATING END FOR A LENGTH OF 5.08 [$.200$] MIN, $1.27\mu\text{m}$ [$.000050$] MIN TIN-LEAD PER MIL-T-10727 FOR A LENGTH OF 5.69 [$.224$] MIN ON OPPOSITE END, BOTH OVER $1.27\mu\text{m}$ [$.000050$] MIN NICKEL PER QQ-N-290 ON ENTIRE CONTACT.
- 11 $1.27\mu\text{m}$ [$.000050$] MIN TIN PER MIL-T-10727 OVER $1.27\mu\text{m}$ [$.000050$] MIN NICKEL PER QQ-N-290.
- 12 $0.38\mu\text{m}$ [$.000015$] MIN GOLD PER MIL-G-45204 ON MATING END FOR A LENGTH OF 5.08 [$.200$] MIN, $1.27\mu\text{m}$ [$.000050$] MIN TIN FOR A LENGTH OF 5.69 [$.224$] MIN ON OPPOSITE END, BOTH OVER $1.27\mu\text{m}$ [$.000050$] MIN NICKEL PER QQ-N-290 ON ENTIRE CONTACT.
- 13 $2.54\mu\text{m}$ [$.000100$] MIN SILVER OVER $0.76\mu\text{m}$ [$.000030$] MIN NICKEL PER QQ-N-290
- 14 OBSOLETE PARTS: OBSOLETE CIS STREAMLINING PER D.RENAUD/D.SINISI

14	OBSOLETE	1	13	BRASS	-	2-66102-8
		1	12	BRASS	-	-2-66102-7-
		1	11	BRASS	1-66103-8	2-66102-6
		1	11	BRASS	1-66103-8	2-66102-5
14	OBSOLETE	1	10	BRASS	1-66103-3	-2-66102-3-
	OBSOLETE	1	2	PHOSPHOR BRONZE	1-66103-2	2-66102-2
	OBSOLETE	1	7	PHOSPHOR BRONZE	1-66103-1	2-66102-1
	OBSOLETE	1	6	BRASS	1-66103-0	1-66102-7
		1	2	BRASS	66103-4	66102-9
		1	4	BRASS	66103-3	66102-8
		1	7	BRASS	66103-2	66102-7
		1	3	BRASS	66103-1	66102-6
	STANDARD		2	BRASS	66103-4	66102-4
	STANDARD		4	BRASS	66103-3	66102-3
	STANDARD		7	BRASS	66103-2	66102-2
	STANDARD		3	BRASS	66103-1	66102-1
	REELING		PIN BODY FINISH	PIN BODY	LOOSE PIECE REF	PART NO

THIS DRAWING IS A CONTROLLED DOCUMENT.

DIMENSIONS: mm [INCHES] TOLERANCES UNLESS OTHERWISE SPECIFIED:

0 PLC	± -
1 PLC	± -
2 PLC	± 0.13[.005]
3 PLC	± -
4 PLC	± -
ANGLES	± -
FINISH	SEE TABLE

MATERIAL: SEE CALLOUTS

TE Connectivity
 PIN ASSEMBLY, .062, TYPE III+

SIZE: A2 CAGE CODE: 00779 DRAWING NO: C-66102 RESTRICTED TO: -

SCALE: 8:1 SHEET: 1 of 1 REV: AU1