

## bq27220 Single-Cell CEDV Fuel Gauge

### 1 Features

- Single-Cell Li-Ion Battery Fuel Gauge
  - Resides in Pack or on System Board
  - Supports Embedded or Removable Batteries
  - Powers Directly from Battery with Integrated LDO
  - Supports a Low-Value (10-m $\Omega$ ) External Sense Resistor
- Ultra-Low Power Consumption in NORMAL (50  $\mu$ A) and SLEEP (9  $\mu$ A) Modes
- Battery Fuel Gauging Based on Compensated End-of-Discharge Voltage (CEDV) Technology
  - Reports Remaining Capacity and State-of-Charge (SOC) with Smoothing Filter
  - Adjusts Automatically for Battery Aging, Self-Discharge, Temperature, and Rate Changes
  - Provides Battery State-of-Health (Aging) Estimation
- Microcontroller Peripheral Supports:
  - 400-kHz I<sup>2</sup>C™ Serial Interface
  - Configurable SOC Interrupt OR Battery Low Digital Output Warning
  - Internal Temperature Sensor OR Host-Reported Temperature OR External Thermistor

### 2 Applications

- Smartphones and Feature Phones
- Tablets
- Wearables
- Building Automation
- Portable Medical/Industrial Handsets
- Portable Audio
- Gaming

### 3 Description

The Texas Instruments bq27220 battery fuel gauge is a single-cell gauge that requires minimal user-configuration and system microcontroller firmware development, leading to quick system bring-up. The bq27220 device uses the Compensated End-of-Discharge Voltage (CEDV) algorithm for fuel gauging, and provides information such as remaining battery capacity (mAh), state-of-charge (%), runtime-to-empty (min), battery voltage (mV), temperature ( $^{\circ}$ C), and state-of-health (%).

The bq27220 battery fuel gauge has ultra-low power consumption in NORMAL (50  $\mu$ A) and SLEEP (9  $\mu$ A) modes, leading to longer battery runtime. Configurable interrupts help save system power and free up the host from continuous polling. Accurate temperature sensing is supported via an external thermistor.

Customers can use preloaded CEDV parameters in ROM or can generate custom chemistry parameters using TI's web-based tool, [GAUGEPARCAL](#). Custom-generated parameters can be either programmed in the device RAM by the host on power up of the system or customers can program the parameters to an onboard One-Time Programmable (OTP) memory.

Battery fuel gauging with the bq27220 device requires connections only to PACK+ (P+) and PACK– (P–) for a removable battery pack or embedded battery circuit. The tiny, 9-ball, 1.62 mm  $\times$  1.58 mm, 0.5-mm pitch NanoFree™ chip scale package (DSBGA) is ideal for space-constrained applications.

#### Device Information<sup>(1)</sup>

| PART NUMBER | PACKAGE | BODY SIZE (NOM)          |
|-------------|---------|--------------------------|
| bq27220     | YZF (9) | 1.62 mm $\times$ 1.58 mm |

(1) For all available packages, see the orderable addendum at the end of the data sheet.

#### Simplified Schematic (System-Side)

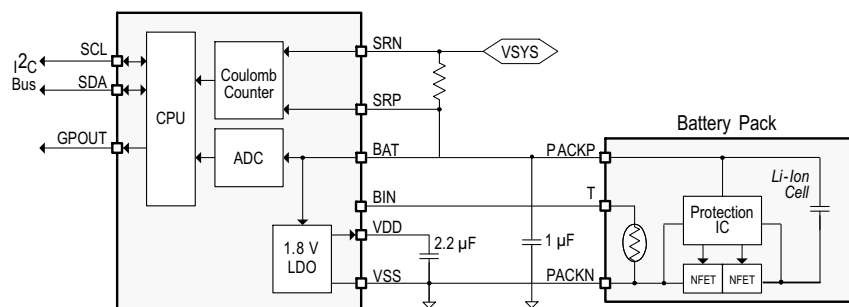

## Table of Contents

|   |          |  |           |
|---|----------|--|-----------|
| <b>1 Features</b> .....   | <b>1</b> | 6.13 Typical Characteristics .....                               | <b>8</b>  |
| <b>2 Applications</b> .....   | <b>1</b> | <b>7 Detailed Description</b> .....                              | <b>9</b>  |
| <b>3 Description</b> .....  | <b>1</b> | 7.1 Overview .....   | <b>9</b>  |
| <b>4 Revision History</b> .....   | <b>2</b> | 7.2 Functional Block Diagram (System-Side Configuration) .....   | <b>9</b>  |
| <b>5 Pin Configuration and Functions</b> .....  | <b>3</b> | 7.3 Feature Description .....                                    | <b>9</b>  |
| <b>6 Specifications</b> .....   | <b>4</b> | 7.4 Device Functional Modes .....                                | <b>11</b> |
| 6.1 Absolute Maximum Ratings .....  | <b>4</b> | <b>8 Application and Implementation</b> .....                    | <b>12</b> |
| 6.2 ESD Ratings .....   | <b>4</b> | 8.1 Application Information .....                                | <b>12</b> |
| 6.3 Recommended Operating Conditions .....  | <b>5</b> | 8.2 Typical Applications .....                                   | <b>12</b> |
| 6.4 Thermal Information .....   | <b>5</b> | <b>9 Power Supply Recommendation</b> .....                       | <b>15</b> |
| 6.5 Supply Current .....  | <b>5</b> | 9.1 Power Supply Decoupling .....                                | <b>15</b> |
| 6.6 Digital Input and Output DC Characteristics .....                                 | <b>5</b> | <b>10 Layout</b> .....   | <b>15</b> |
| 6.7 LDO Regulator, Wake-up, and Auto-Shutdown DC Characteristics .....                | <b>6</b> | 10.1 Layout Guidelines .....                                     | <b>15</b> |
| 6.8 LDO Regulator, Wake-up, and Auto-shutdown AC Characteristics .....                | <b>6</b> | 10.2 Layout Example .....  | <b>16</b> |
| 6.9 ADC (Temperature and Cell Measurement) Characteristics .....                      | <b>6</b> | <b>11 Device and Documentation Support</b> .....                 | <b>17</b> |
| 6.10 Integrating ADC (Coulomb Counter) Characteristics .....                          | <b>6</b> | 11.1 Documentation Support .....                                 | <b>17</b> |
| 6.11 I <sup>2</sup> C-Compatible Interface Communication Timing Characteristics ..... | <b>7</b> | 11.2 Community Resources .....                                   | <b>17</b> |
| 6.12 SHUTDOWN and WAKE-UP Timing .....  | <b>8</b> | 11.3 Trademarks .....  | <b>17</b> |
|   |          | 11.4 Electrostatic Discharge Caution .....                       | <b>17</b> |
|   |          | 11.5 Glossary .....  | <b>17</b> |
|   |          | <b>12 Mechanical, Packaging, and Orderable Information</b> ..... | <b>17</b> |

## 4 Revision History

| DATE       | REVISION | NOTES                              |
|------------|----------|------------------------------------|
| April 2016 | A        | PRODUCT PREVIEW to Production Data |

## 5 Pin Configuration and Functions

Top View

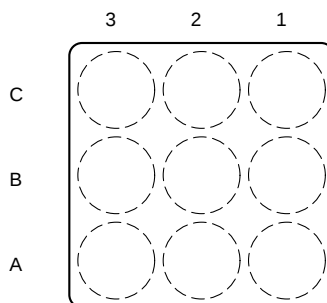

Bottom View

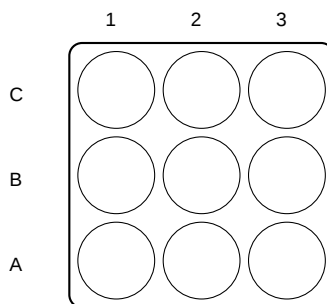

### Pin Functions

| PIN  |        | TYPE                  | DESCRIPTION  |
|------|--------|-----------------------|--|
| NAME | NUMBER |                       |  |
| BAT  | C3     | PI, AI <sup>(1)</sup> | LDO regulator input and battery voltage measurement input. Kelvin sense connect to the positive battery terminal (PACKP). Connect a capacitor (1 $\mu$ F) between BAT and $V_{SS}$ . Place the capacitor close to the gauge.   |
| BIN  | B1     | DI                    | Battery insertion detection input. If <i>OpConfig</i> <b>[BI_PU_EN]</b> = 1 (default), a logic low on the pin is detected as battery insertion. For a removable pack, the BIN pin can be connected to $V_{SS}$ through a pulldown resistor on the pack, typically the 10-k $\Omega$ thermistor; the system board should use a 1.8-M $\Omega$ pullup resistor to $V_{DD}$ to ensure the BIN pin is high when a battery is removed. If the battery is embedded in the system or in the pack, it is recommended to leave <b>[BI_PU_EN]</b> = 1 and use a 10-k $\Omega$ pulldown resistor from BIN to $V_{SS}$ . If <b>[BI_PU_EN]</b> = 0, then the host must inform the gauge of battery insertion and removal with the <i>BAT_INSERT</i> and <i>BAT_REMOVE</i> subcommands. A 10-k $\Omega$ pulldown resistor should be placed between BIN and $V_{SS}$ , even if this pin is unused.<br><b>NOTE:</b> The BIN pin must not be shorted directly to $V_{CC}$ or $V_{SS}$ and any pullup resistor on the BIN pin must be connected only to $V_{DD}$ and not an external voltage rail. If an external thermistor is used for temperature input, the thermistor should be connected between this pin and $V_{SS}$ . |

(1) IO = Digital input-output, AI = Analog input, P = Power connection

### Pin Functions (continued)

| PIN             |        | TYPE | DESCRIPTION   |
|-----------------|--------|------|---|
| NAME            | NUMBER |      |   |
| GPOUT           | A1     | DO   | This open-drain output can be configured to indicate BAT_LOW when the <i>OpConfig</i> <b>[BATLOWEN]</b> bit is set. By default <b>[BATLOWEN]</b> is cleared and this pin performs an interrupt function (SOC_INT) by pulsing for specific events, such as a change in state-of-charge. Signal polarity for these functions is controlled by the <b>[GPIOPOL]</b> configuration bit. This pin should not be left floating, even if unused; therefore, a 10-k $\Omega$ pullup resistor is recommended. If the device is in SHUTDOWN mode, toggling GPOUT makes the gauge exit SHUTDOWN. It is recommended to connect GPOUT to a GPIO of the host MCU so that in case of any inadvertent shutdown condition, the gauge can be commanded to come out of SHUTDOWN. |
| SCL             | A3     | DIO  | Slave I <sup>2</sup> C serial bus for communication with system (Master). Open-drain pins. Use with external 10-k $\Omega$ pullup resistors (typical) for each pin. If the external pullup resistors will be disconnected from these pins during normal operation, recommend using external 1-M $\Omega$ pulldown resistors to V <sub>SS</sub> at each pin to avoid floating inputs.  |
| SDA             | A2     | DIO  |   |
| SRN             | C2     | AI   | Coulomb counter differential inputs expecting an external 10-m $\Omega$ , 1% sense resistor. For system-side configurations, Kelvin sense connect SRP to the positive battery terminal (PACKP) side of the external sense resistor. Kelvin sense connect SRN to the other side of the external sense resistor with the positive connection to the system (VSYS). For pack-side configurations with low-side sensing, connect SRP to PACK– and SRN to Cell–. See the <a href="#">Simplified Schematic</a> . No calibration is required. The fuel gauge is pre-calibrated for a standard 10-m $\Omega$ , 1% sense resistor.   |
| SRP             | C1     | AI   |   |
| V <sub>DD</sub> | B3     | PO   | 1.8-V regulator output. Decouple with a 2.2- $\mu$ F ceramic capacitor to V <sub>SS</sub> . This pin is not intended to provide power for other devices in the system.  |
| V <sub>SS</sub> | B2     | PI   | Ground pin  |

## 6 Specifications

### 6.1 Absolute Maximum Ratings

Over operating free-air temperature range (unless otherwise noted)<sup>(1)</sup>

|                   |   | MIN  | MAX                    | UNIT |
|-------------------|---|------|------------------------|------|
| V <sub>BAT</sub>  | BAT pin input voltage range                             | –0.3 | 6                      | V    |
| V <sub>SR</sub>   | SRP and SRN pins input voltage range                    | –0.3 | V <sub>BAT</sub> + 0.3 | V    |
|                   | Differential voltage across SRP and SRN. ABS(SRP – SRN) |      | 2                      | V    |
| V <sub>DD</sub>   | V <sub>DD</sub> pin supply voltage range (LDO output)   | –0.3 | 2                      | V    |
| V <sub>IOD</sub>  | Open-drain IO pins (SDA, SCL)                           | –0.3 | 6                      | V    |
| V <sub>IOPP</sub> | Push-pull IO pins (BIN)                                 | –0.3 | V <sub>DD</sub> + 0.3  | V    |
| T <sub>A</sub>    | Operating free-air temperature range                    | –40  | 85                     | °C   |
|                   | Storage temperature, T <sub>stg</sub>                   | –65  | 150                    | °C   |

- (1) Stresses beyond those listed under "absolute maximum ratings" may cause permanent damage to the device. These are stress ratings only, and functional operation of the device at these or any other conditions beyond those indicated under "recommended operating conditions" is not implied. Exposure to absolute-maximum-rated conditions for extended periods may affect device reliability.

### 6.2 ESD Ratings

|                    |                         |  | VALUE | UNIT |
|--------------------|-------------------------|--|-------|------|
| V <sub>(ESD)</sub> | Electrostatic discharge | Human body model (HBM), per ANSI/ESDA/JEDEC JS-001 <sup>(1)</sup>              | ±1500 | V    |
|                    |                         | Charged-device model (CDM), per JEDEC specification JESD22-C101 <sup>(2)</sup> | ±250  |      |

(1) JEDEC document JEP155 states that 500-V HBM allows safe manufacturing with a standard ESD control process.

(2) JEDEC document JEP157 states that 250-V CDM allows safe manufacturing with a standard ESD control process.

### 6.3 Recommended Operating Conditions

 $T_A = 30^\circ\text{C}$  and  $V_{BAT} = 3.6\text{ V}$  (unless otherwise noted)

|                   |  | MIN  | NOM | MAX | UNIT          |
|-------------------|--|------|-----|-----|---------------|
| $C_{BAT}^{(1)}$   | External input capacitor for internal LDO between BAT and $V_{SS}$       |      | 0.1 |     | $\mu\text{F}$ |
| $C_{LDO18}^{(1)}$ | External output capacitor for internal LDO between $V_{DD}$ and $V_{SS}$ |      | 2.2 |     | $\mu\text{F}$ |
| $V_{PU}^{(1)}$    | External pullup voltage for open-drain pins (SDA, SCL, GPOUT)            | 1.62 |     | 3.6 | V             |

(1) Specified by design. Not production tested.

### 6.4 Thermal Information

| THERMAL METRIC <sup>(1)</sup> |  | bq27220     |  |  | UNIT               |
|-------------------------------|--|-------------|--|--|--------------------|
|                               |  | YZF (DSBGA) |  |  |                    |
|                               |  | 9 PINS      |  |  |                    |
| $R_{\theta JA}$               | Junction-to-ambient thermal resistance       | 64.1        |  |  | $^\circ\text{C/W}$ |
| $R_{\theta Jctop}$            | Junction-to-case (top) thermal resistance    | 59.8        |  |  | $^\circ\text{C/W}$ |
| $R_{\theta JB}$               | Junction-to-board thermal resistance         | 52.7        |  |  | $^\circ\text{C/W}$ |
| $\Psi_{JT}$                   | Junction-to-top characterization parameter   | 0.3         |  |  | $^\circ\text{C/W}$ |
| $\Psi_{JB}$                   | Junction-to-board characterization parameter | 28.3        |  |  | $^\circ\text{C/W}$ |
| $R_{\theta Jcbot}$            | Junction-to-case (bottom) thermal resistance | 2.4         |  |  | $^\circ\text{C/W}$ |

(1) For more information about traditional and new thermal metrics, see the *IC Package Thermal Metrics* application report, [SPRA953](#)

### 6.5 Supply Current

 $T_A = 30^\circ\text{C}$  and  $V_{BAT} = 3.6\text{ V}$  (unless otherwise noted)

| PARAMETER       | TEST CONDITIONS       | MIN | TYP | MAX | UNIT          |
|-----------------|-----------------------|-----|-----|-----|---------------|
| $I_{CC}^{(1)}$  | NORMAL mode current   |     | 50  |     | $\mu\text{A}$ |
| $I_{SLP}^{(1)}$ | SLEEP mode current    |     | 9   |     | $\mu\text{A}$ |
| $I_{SD}^{(1)}$  | SHUTDOWN mode current |     | 0.6 |     | $\mu\text{A}$ |

(1) Specified by design. Not production tested.

(2) Wake Comparator Disabled.

### 6.6 Digital Input and Output DC Characteristics

 $T_A = -40^\circ\text{C}$  to  $85^\circ\text{C}$ , typical values at  $T_A = 30^\circ\text{C}$  and  $V_{BAT} = 3.6\text{ V}$  (unless otherwise noted)

| PARAMETER      | TEST CONDITIONS                              | MIN                                  | TYP | MAX | UNIT          |
|----------------|--|--------------------------------------|-----|-----|---------------|
| $V_{IH(OD)}$   | Input voltage, high <sup>(2)</sup>           | External pullup resistor to $V_{PU}$ |     |     | V             |
| $V_{IH(PP)}$   | Input voltage, high <sup>(3)</sup>           |                                      |     | 1.4 | V             |
| $V_{IL}$       | Input voltage, low <sup>(2) (3)</sup>        |                                      |     | 0.6 | V             |
| $V_{OL}$       | Output voltage, low <sup>(2)</sup>           |                                      |     | 0.6 | V             |
| $I_{OH}$       | Output source current, high <sup>(2)</sup>   |                                      |     | 0.5 | mA            |
| $I_{OL(OD)}$   | Output sink current, low <sup>(2)</sup>      |                                      |     | -3  | mA            |
| $C_{IN}^{(1)}$ | Input capacitance <sup>(2)(3)</sup>          |                                      |     | 5   | pF            |
| $I_{lkg}$      | Input leakage current (SCL, SDA, BIN, GPOUT) |                                      |     | 1   | $\mu\text{A}$ |

(1) Specified by design. Not production tested.

(2) Open Drain pins: (SCL, SDA, GPOUT)

(3) Push-Pull pin: (BIN)

## 6.7 LDO Regulator, Wake-up, and Auto-Shutdown DC Characteristics

 $T_A = -40^{\circ}\text{C}$  to  $85^{\circ}\text{C}$ , typical values at  $T_A = 30^{\circ}\text{C}$  and  $V_{\text{BAT}} = 3.6\text{ V}$  (unless otherwise noted)

| PARAMETER                  |  | TEST CONDITIONS                | MIN  | TYP  | MAX | UNIT |
|----------------------------|--|--------------------------------|------|------|-----|------|
| $V_{\text{BAT}}$           | BAT pin regulator input  |                                | 2.45 |      | 4.5 | V    |
| $V_{\text{DD}}$            | Regulator output voltage   |                                |      | 1.85 |     | V    |
| $\text{UVLO}_{\text{IT+}}$ | $V_{\text{BAT}}$ undervoltage lock-out LDO wake-up rising threshold        |                                |      | 2    |     | V    |
| $\text{UVLO}_{\text{IT-}}$ | $V_{\text{BAT}}$ undervoltage lock-out LDO auto-shutdown falling threshold |                                |      | 1.95 |     | V    |
| $V_{\text{WU+}}^{(1)}$     | GPOUT (input) LDO Wake-up rising edge threshold <sup>(2)</sup>             | LDO Wake-up from SHUTDOWN mode | 1.2  |      |     | V    |

(1) Specified by design. Not production tested.

(2) If the device is commanded to SHUTDOWN via I<sup>2</sup>C with  $V_{\text{BAT}} > \text{UVLO}_{\text{IT+}}$ , a wake-up rising edge trigger is required on GPOUT.

## 6.8 LDO Regulator, Wake-up, and Auto-shutdown AC Characteristics

 $T_A = -40^{\circ}\text{C}$  to  $85^{\circ}\text{C}$ , typical values at  $T_A = 30^{\circ}\text{C}$  and  $V_{\text{BAT}} = 3.6\text{ V}$  (unless otherwise noted)

| PARAMETER                |                                      | TEST CONDITIONS  | MIN | TYP | MAX | UNIT          |
|--------------------------|--------------------------------------|--|-----|-----|-----|---------------|
| $t_{\text{SHDN}}^{(1)}$  | SHUTDOWN entry time                  | Time delay from SHUTDOWN command to LDO output disable.  |     |     | 250 | ms            |
| $t_{\text{SHUP}}^{(1)}$  | SHUTDOWN GPOUT low time              | Minimum low time of GPOUT (input) in SHUTDOWN before WAKEUP                                    | 10  |     |     | $\mu\text{s}$ |
| $t_{\text{VDD}}^{(1)}$   | Initial $V_{\text{DD}}$ output delay |  |     | 13  |     | ms            |
| $t_{\text{WUVDD}}^{(1)}$ | Wake-up $V_{\text{DD}}$ output delay | Time delay from rising edge of GPOUT (input) to nominal $V_{\text{DD}}$ output.                |     | 8   |     | ms            |
| $t_{\text{PUCD}}$        | Power-up communication delay         | Time delay from rising edge of BAT to the Active state. Includes firmware initialization time. |     | 250 |     | ms            |

(1) Specified by design. Not production tested.

## 6.9 ADC (Temperature and Cell Measurement) Characteristics

 $T_A = -40^{\circ}\text{C}$  to  $85^{\circ}\text{C}$ ; typical values at  $T_A = 30^{\circ}\text{C}$  and  $V_{\text{BAT}} = 3.6\text{ V}$  (unless otherwise noted)

| PARAMETER              |                                   | TEST CONDITIONS         | MIN  | TYP | MAX | UNIT |
|------------------------|-----------------------------------|-------------------------|------|-----|-----|------|
| $V_{\text{IN(BAT)}}$   | BAT pin voltage measurement range | Voltage divider enabled | 2.45 |     | 4.5 | V    |
| $t_{\text{ADC\_CONV}}$ | Conversion time                   |                         |      | 125 |     | ms   |
|                        | Effective resolution              |                         |      | 15  |     | bits |

(1) Specified by design. Not tested in production.

## 6.10 Integrating ADC (Coulomb Counter) Characteristics

 $T_A = -40^{\circ}\text{C}$  to  $85^{\circ}\text{C}$ ; typical values at  $T_A = 30^{\circ}\text{C}$  and  $V_{\text{BAT}} = 3.6\text{ V}$  (unless otherwise noted)

| PARAMETER             |   | TEST CONDITIONS   | MIN | TYP      | MAX              | UNIT |
|-----------------------|---|-------------------|-----|----------|------------------|------|
| $V_{\text{SRCM}}$     | Input voltage range of SRN, SRP pins          |                   | VSS |          | $V_{\text{BAT}}$ | V    |
| $V_{\text{SRDM}}$     | Input differential voltage range of VSRP–VSRN |                   |     | $\pm 80$ |                  | mV   |
| $t_{\text{SR\_CONV}}$ | Conversion time                               | Single conversion |     | 1        |                  | s    |
|                       | Effective Resolution                          | Single conversion |     | 16       |                  | bits |

(1) Specified by design. Not tested in production.

## 6.11 I<sup>2</sup>C-Compatible Interface Communication Timing Characteristics

T<sub>A</sub> = -40°C to 85°C; typical values at T<sub>A</sub> = 30°C and V<sub>BAT</sub> = 3.6 V (unless otherwise noted)

|                                |                                      | MIN                           | NOM | MAX | UNIT |
|--------------------------------|--------------------------------------|-------------------------------|-----|-----|------|
| <b>Standard Mode (100 kHz)</b> |                                      |                               |     |     |      |
| t <sub>d(STA)</sub>            | Start to first falling edge of SCL   | 4                             |     |     | µs   |
| t <sub>w(L)</sub>              | SCL pulse duration (low)             | 4.7                           |     |     | µs   |
| t <sub>w(H)</sub>              | SCL pulse duration (high)            | 4                             |     |     | µs   |
| t <sub>su(STA)</sub>           | Setup for repeated start             | 4.7                           |     |     | µs   |
| t <sub>su(DAT)</sub>           | Data setup time                      | Host drives SDA               | 250 |     | ns   |
| t <sub>h(DAT)</sub>            | Data hold time                       | Host drives SDA               | 0   |     | ns   |
| t <sub>su(STOP)</sub>          | Setup time for stop                  | 4                             |     |     | µs   |
| t <sub>(BUF)</sub>             | Bus free time between stop and start | Includes Command Waiting Time | 66  |     | µs   |
| t <sub>f</sub>                 | SCL or SDA fall time <sup>(1)</sup>  |                               |     | 300 | ns   |
| t <sub>r</sub>                 | SCL or SDA rise time <sup>(1)</sup>  |                               |     | 300 | ns   |
| f <sub>SCL</sub>               | Clock frequency <sup>(2)</sup>       |                               |     | 100 | kHz  |
| <b>Fast Mode (400 kHz)</b>     |                                      |                               |     |     |      |
| t <sub>d(STA)</sub>            | Start to first falling edge of SCL   | 600                           |     |     | ns   |
| t <sub>w(L)</sub>              | SCL pulse duration (low)             | 1300                          |     |     | ns   |
| t <sub>w(H)</sub>              | SCL pulse duration (high)            | 600                           |     |     | ns   |
| t <sub>su(STA)</sub>           | Setup for repeated start             | 600                           |     |     | ns   |
| t <sub>su(DAT)</sub>           | Data setup time                      | Host drives SDA               | 100 |     | ns   |
| t <sub>h(DAT)</sub>            | Data hold time                       | Host drives SDA               | 0   |     | ns   |
| t <sub>su(STOP)</sub>          | Setup time for stop                  | 600                           |     |     | ns   |
| t <sub>(BUF)</sub>             | Bus free time between stop and start | Includes Command Waiting Time | 66  |     | µs   |
| t <sub>f</sub>                 | SCL or SDA fall time <sup>(1)</sup>  |                               |     | 300 | ns   |
| t <sub>r</sub>                 | SCL or SDA rise time <sup>(1)</sup>  |                               |     | 300 | ns   |
| f <sub>SCL</sub>               | Clock frequency <sup>(2)</sup>       |                               |     | 400 | kHz  |

(1) Specified by design. Not production tested.

(2) If the clock frequency (f<sub>SCL</sub>) is > 100 kHz, use 1-byte write commands for proper operation. All other transactions types are supported at 400 kHz. (See [I<sup>2</sup>C Interface](#) and [I<sup>2</sup>C Command Waiting Time](#).)

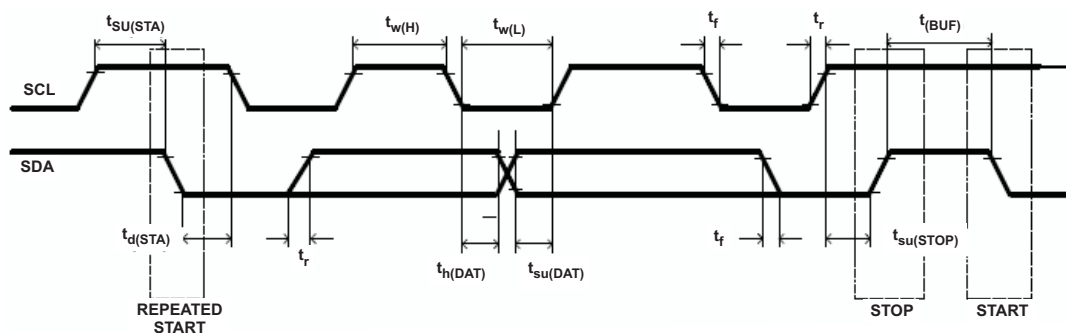
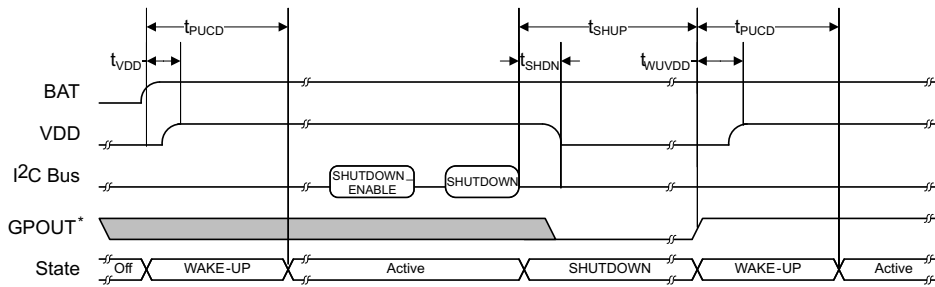

Figure 1. I<sup>2</sup>C-Compatible Interface Timing Diagram

## 6.12 SHUTDOWN and WAKE-UP Timing



\* GPOUT is configured as an input for wakeup signaling.

Figure 2. SHUTDOWN and WAKE-UP Timing Diagram

## 6.13 Typical Characteristics

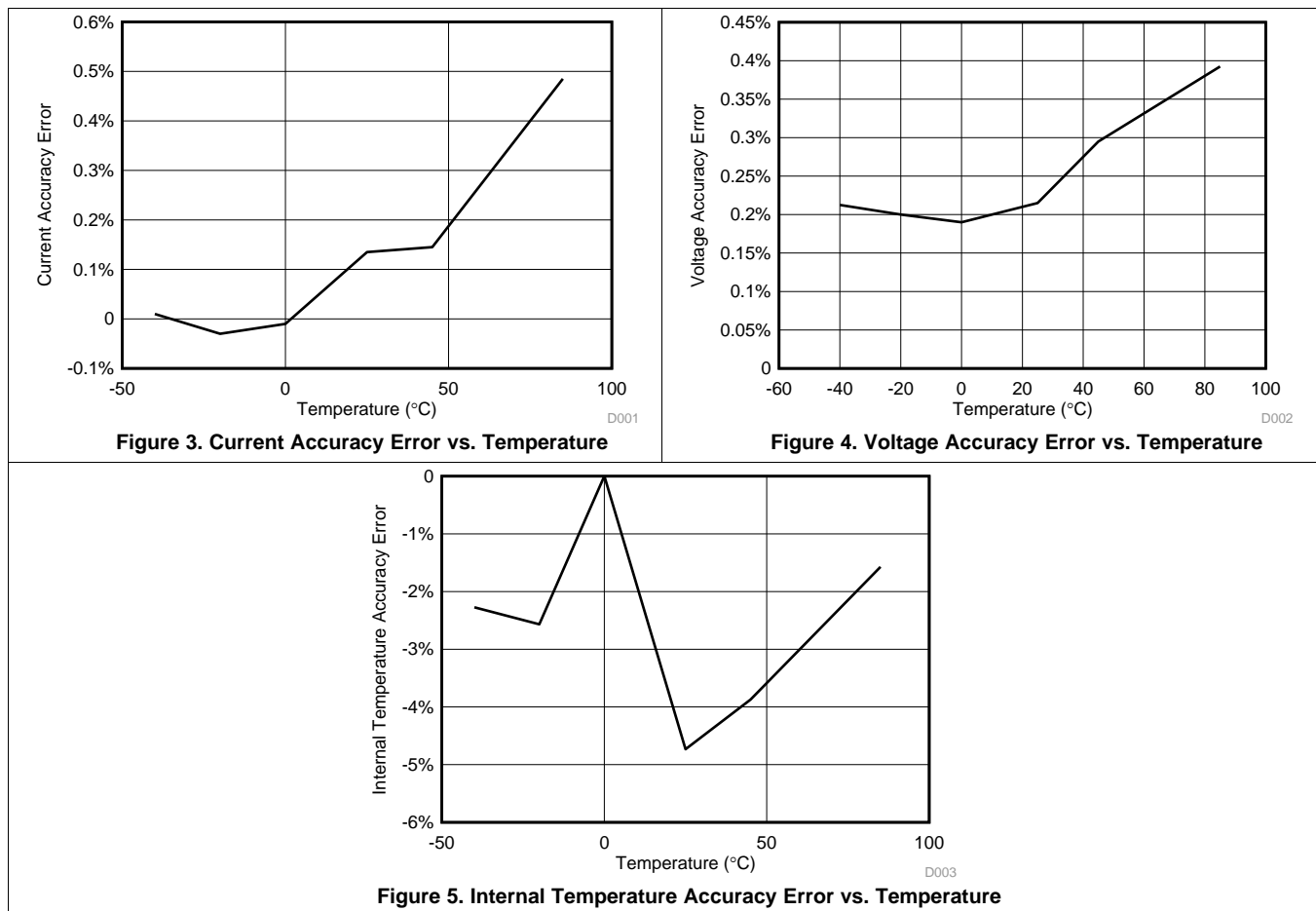



## 7 Detailed Description

### 7.1 Overview

The bq27220 fuel gauge accurately predicts the battery capacity and other operational characteristics of a single Li-based rechargeable cell. It can be interrogated by a system processor to provide cell information such as state-of-charge (SoC). The bq27220 monitors charge and discharge activity by sensing the voltage across a small value resistor (10 mΩ typical) between the SRP and SRN pins and in series with the battery. By integrating charge passing through the battery, the battery's SOC is adjusted during battery charge or discharge.

The fuel gauging is derived from the Compensated End of Discharge Voltage (CEDV) method, which uses a mathematical model to correlate remaining state of charge (RSOC) and voltage near to the end of discharge state. This requires a full discharge cycle for a single point FCC update. The implementation models cell voltage (OCV) as a function of battery state of charge (SOC), temperature, and current. The impedance is also a function of SOC and temperature, all of which can be satisfied by using seven parameters: EMF, C0, R0, T0, R1, TC, C1.

#### NOTE

The following formatting conventions are used in this document:

**Commands:** *italics* with parentheses() and no breaking spaces, for example, *Control()*.

**Data Flash:** *italics*, **bold**, and breaking spaces, for example, ***Design Capacity***.

**Register bits and flags:** *italics* with brackets [ ], for example, *[TDA]*

**Data flash bits:** *italics*, **bold**, and brackets [ ], for example, ***[LED1]***

**Modes and states:** ALL CAPITALS, for example, UNSEALED mode.

### 7.2 Functional Block Diagram (System-Side Configuration)

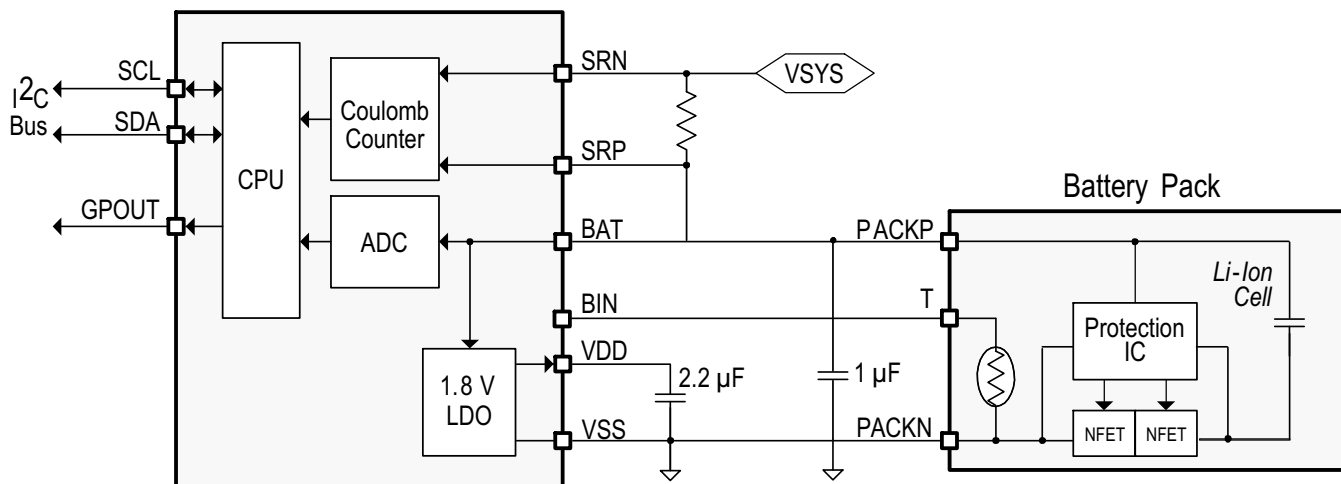

### 7.3 Feature Description

Information is accessed through a series of commands called *Standard Commands*. Further capabilities are provided by the additional *Extended Commands* set. Both sets of commands, indicated by the general format *Command*), are used to read and write information within the control and status registers, as well as its data locations. Commands are sent from the system to the gauge using the I<sup>2</sup>C serial communications engine, and can be executed during application development, system manufacture, or end-equipment operation.

The fuel gauge measures the charging and discharging of the battery by monitoring the voltage across a small-value sense resistor. When a cell is attached to the fuel gauge, cell impedance is computed based on cell current, cell open-circuit voltage (OCV), and cell voltage under loading conditions.

The fuel gauge uses an integrated temperature sensor for estimating cell temperature. Alternatively, the host processor can provide temperature data for the fuel gauge.

## Feature Description (continued)

For more details, see the *bq27220 Technical Reference Manual (SLUUBD4)*.

The external temperature sensing is optimized with the use of a high accuracy negative temperature coefficient (NTC) thermistor with  $R_{25} = 10.0\text{ k}\Omega \pm 1\%$ .  $B_{25/85} = 3435\text{K} \pm 1\%$  (such as Semitec NTC 103AT) on the BIN pin. Alternatively, the bq27220 can also be configured to use its internal temperature sensor or receive temperature data from the host processor. The bq27220 uses temperature to monitor the battery-pack environment, which is used for fuel gauging and cell protection functionality.

### 7.3.1 Communications

#### 7.3.1.1 I<sup>2</sup>C Interface

The fuel gauge supports the standard I<sup>2</sup>C read, incremental read, quick read, one-byte write, and incremental write functions. The 7-bit device address (ADDR) is the most significant 7 bits of the hex address and is fixed as 1010101. The first 8 bits of the I<sup>2</sup>C protocol are, therefore, 0xAA or 0xAB for write or read, respectively.

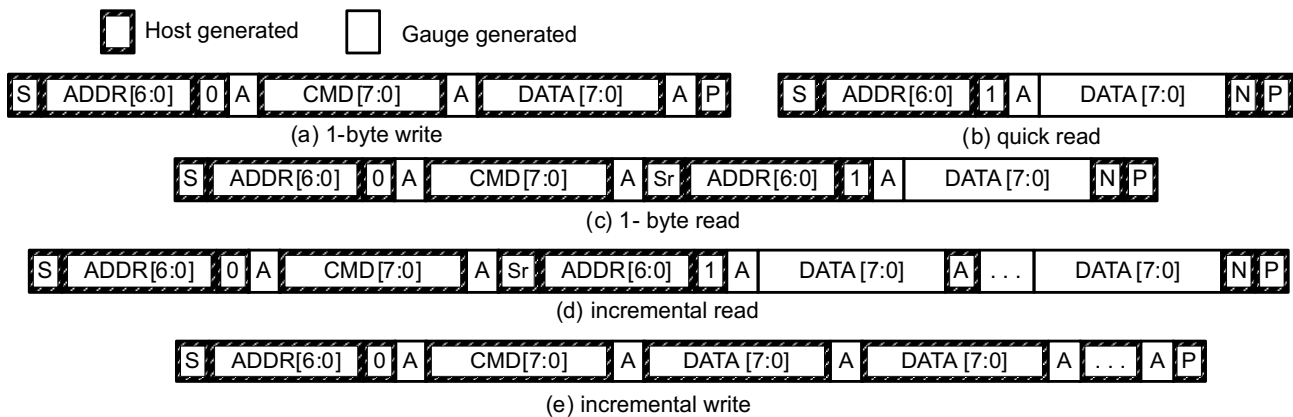

(S = Start, Sr = Repeated Start, A = Acknowledge, N = No Acknowledge, and P = Stop).

**Figure 6. I<sup>2</sup>C Interface Read and Write Functions**

The quick read returns data at the address indicated by the address pointer. The address pointer, a register internal to the I<sup>2</sup>C communication engine, increments whenever data is acknowledged by the fuel gauge or the I<sup>2</sup>C master. “Quick writes” function in the same manner and are a convenient means of sending multiple bytes to consecutive command locations (such as two-byte commands that require two bytes of data).

The following command sequences are not supported:

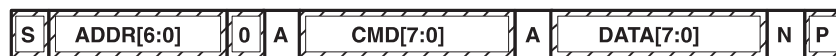

**Figure 7. Attempt to Write a Read-Only Address (NACK After Data Sent By Master)**



**Figure 8. Attempt to Read an Address Above 0x6B (NACK Command)**

#### 7.3.1.2 I<sup>2</sup>C Time Out

The I<sup>2</sup>C engine releases both SDA and SCL if the I<sup>2</sup>C bus is held low for 2 seconds. If the fuel gauge is holding the lines, releasing them frees them for the master to drive the lines. If an external condition is holding either of the lines low, the I<sup>2</sup>C engine enters the low-power SLEEP mode.

## Feature Description (continued)

### 7.3.1.3 I<sup>2</sup>C Command Waiting Time

To ensure proper operation at 400 kHz, a  $t_{(BUF)} \geq 66 \mu s$  bus-free waiting time must be inserted between all packets addressed to the fuel gauge. In addition, if the SCL clock frequency ( $f_{SCL}$ ) is  $> 100$  kHz, use individual 1-byte write commands for proper data flow control. Figure 9 shows the standard waiting time required between issuing the control subcommand the reading the status result. For read-write standard commands, a minimum of 2 seconds is required to get the result updated. For read-only standard commands, there is no waiting time required, but the host must not issue any standard command more than two times per second. Otherwise, the gauge could result in a reset issue due to the expiration of the watchdog timer.

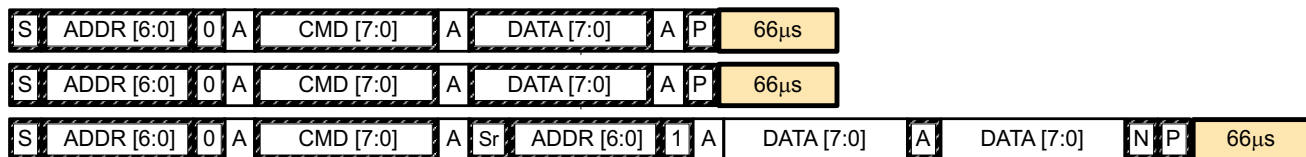

Waiting time inserted between two 1-byte write packets for a subcommand and reading results  
(required for  $100 \text{ kHz} < f_{SCL} \leq 400 \text{ kHz}$ )

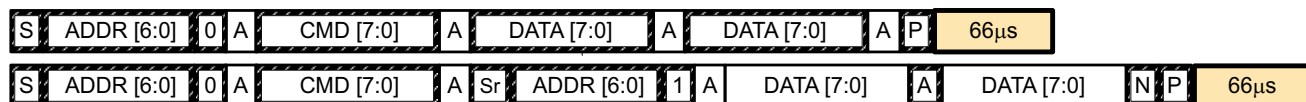

Waiting time inserted between incremental 2-byte write packet for a subcommand and reading results  
(acceptable for  $f_{SCL} \leq 100 \text{ kHz}$ )

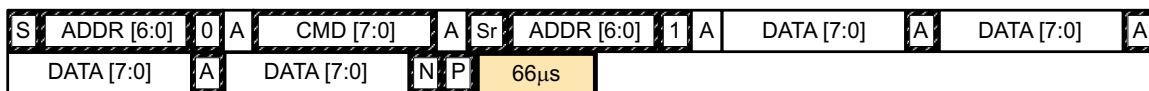

Waiting time inserted after incremental read

**Figure 9. Standard Waiting Time**

### 7.3.1.4 I<sup>2</sup>C Clock Stretching

A clock stretch can occur during all modes of fuel gauge operation. In SLEEP mode, a short  $\leq 100\text{-}\mu s$  clock stretch occurs on all I<sup>2</sup>C traffic as the device must wake-up to process the packet. In the other modes (INITIALIZATION, NORMAL), a  $\leq 4\text{-ms}$  clock stretching period may occur within packets addressed for the fuel gauge as the I<sup>2</sup>C interface performs normal data flow control.

## 7.4 Device Functional Modes

To minimize power consumption, the fuel gauge has several power modes: INITIALIZATION, NORMAL, and SLEEP. The fuel gauge passes automatically between these modes, depending upon the occurrence of specific events, though a system processor can initiate some of these modes directly. For more details, see the *bq27220 Technical Reference Manual* (SLUUBD4).

## 8 Application and Implementation

### NOTE

Information in the following application section is not part of the TI component specification, and TI does not warrant its accuracy or completeness. TI's customers are responsible for determining suitability of components for their purposes. Customers should validate and test their design implementation to confirm system functionality.

### 8.1 Application Information

The bq27220 fuel gauge is a microcontroller peripheral that provides system-side or pack-side fuel gauging for single-cell Li-Ion batteries. The device requires minimal configuration and uses One-Time Programmable (OTP) Non-Volatile Memory (NVM). Battery fuel gauging with the fuel gauge requires connections only to PACK+ and PACK- for a removable battery pack or embedded battery circuit. To allow for optimal performance in the end application, special considerations must be taken to ensure minimization of measurement error through proper printed circuit board (PCB) board layout. Such requirements are detailed in [Design Requirements](#).

### 8.2 Typical Applications

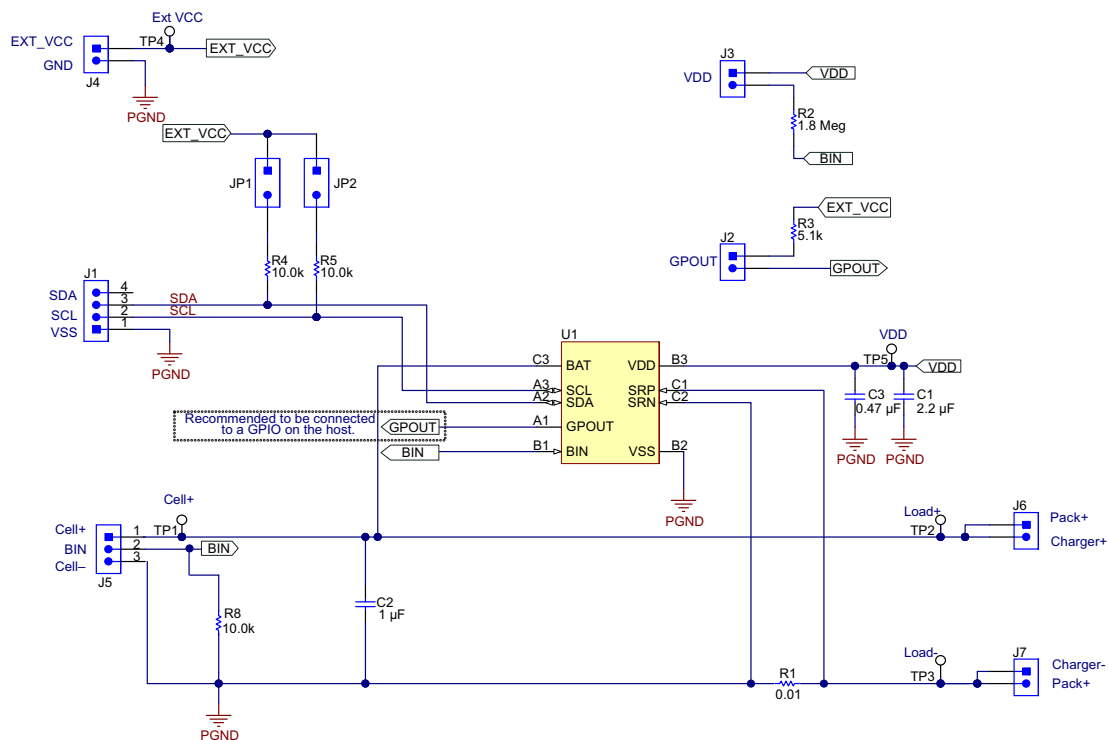

**Figure 10. Typical Application for Pack-Side Using Low-Side Sensing**

#### 8.2.1 Design Requirements

As shipped from the Texas Instruments factory, many bq27220 parameters in OTP NVM are left in the unprogrammed state (zero). This partially programmed configuration facilitates customization for each end application. Upon device reset, the contents of OTP are copied to associated volatile RAM-based data memory blocks. For proper operation, all parameters in RAM-based data memory require initialization — either by updating data memory parameters in a lab/evaluation situation or by programming the OTP for customer production. The *bq27220 Technical Reference Manual (SLUUBD4)* shows the default value and a typically expected value appropriate for most of applications.

## Typical Applications (continued)

### 8.2.2 Detailed Design Procedure

#### 8.2.2.1 BAT Voltage Sense Input

A ceramic capacitor at the input to the BAT pin is used to bypass AC voltage ripple to ground, greatly reducing its influence on battery voltage measurements. It proves most effective in applications with load profiles that exhibit high-frequency current pulses (that is, cell phones) but is recommended for use in all applications to reduce noise on this sensitive high-impedance measurement node.

#### 8.2.2.2 Integrated LDO Capacitor

The fuel gauge has an integrated LDO with an output on the  $V_{DD}$  pin of approximately 1.8 V. A capacitor with a value of at least 2.2  $\mu\text{F}$  should be connected between the  $V_{DD}$  pin and  $V_{SS}$ . The capacitor must be placed close to the gauge IC and have short traces to both the  $V_{DD}$  pin and  $V_{SS}$ . This regulator must not be used to provide power for other devices in the system.

#### 8.2.2.3 Sense Resistor Selection

Any variation encountered in the resistance present between the SRP and SRN pins of the fuel gauge will affect the resulting differential voltage, and derived current, that it senses. As such, it is recommended to select a sense resistor with minimal tolerance and temperature coefficient of resistance (TCR) characteristics. The standard recommendation based on the best compromise between performance and price is a 1% tolerance, 50-ppm drift sense resistor with a 1-W power rating.

### 8.2.3 External Thermistor Support

The fuel gauge temperature sensing circuitry is designed to work with a negative temperature coefficient-type (NTC) thermistor with a characteristic 10-k $\Omega$  resistance at room temperature (25°C). The default curve-fitting coefficients configured in the fuel gauge specifically assume a Semitec 103AT type thermistor profile and so that is the default recommendation for thermistor selection purposes. Moving to a separate thermistor resistance profile (for example, JT-2 or others) requires an update to the default thermistor coefficients, which can be modified in RAM to ensure highest accuracy temperature measurement performance.

**Typical Applications (continued)**

**8.2.4 Application Curves**

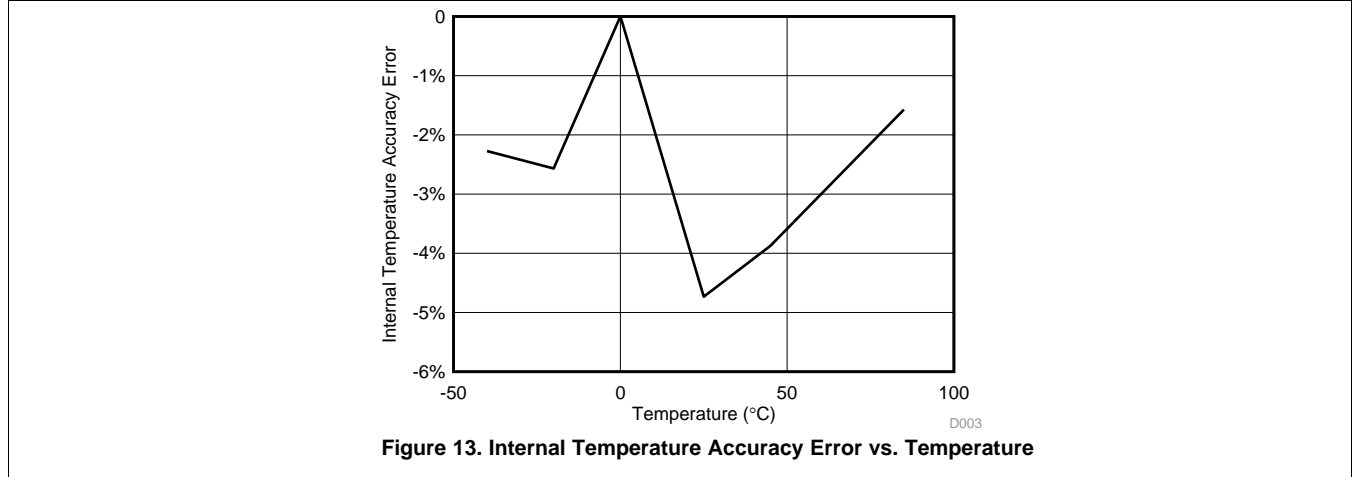
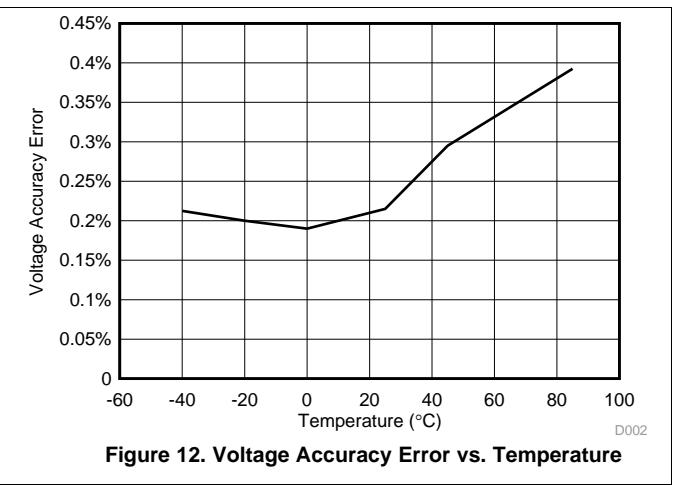
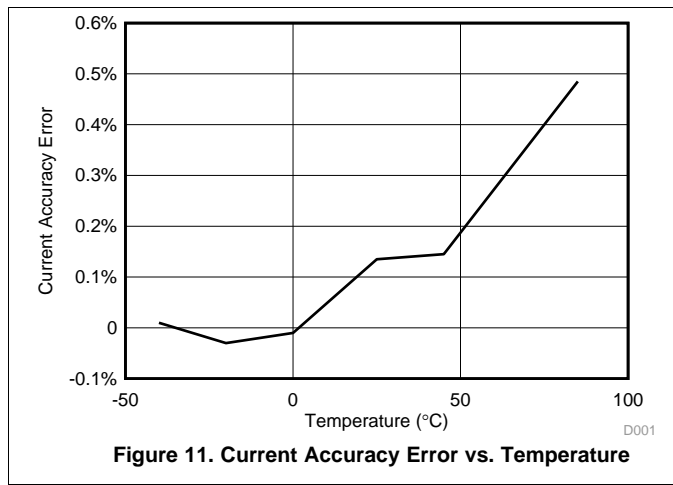

## 9 Power Supply Recommendation

### 9.1 Power Supply Decoupling

The battery connection on the BAT pin is used for two purposes:

- To supply power to the fuel gauge, and
- To provide an input for voltage measurement of the battery.

A capacitor of value of at least 1  $\mu\text{F}$  should be connected between BAT and  $V_{\text{SS}}$ . The capacitor must be placed close to the gauge IC and have short traces to both the BAT pin and  $V_{\text{SS}}$ .

The fuel gauge has an integrated LDO with an output on the  $V_{\text{DD}}$  pin of approximately 1.8 V. A capacitor of value of at least 2.2  $\mu\text{F}$  should be connected between the  $V_{\text{DD}}$  pin and  $V_{\text{SS}}$ . The capacitor must be placed close to the gauge IC and have short traces to both the  $V_{\text{DD}}$  pin and  $V_{\text{SS}}$ . This regulator must not be used to provide power for other devices in the system.

## 10 Layout

### 10.1 Layout Guidelines

- A capacitor of value of at least 2.2  $\mu\text{F}$  is connected between the  $V_{\text{DD}}$  pin and  $V_{\text{SS}}$ . The capacitor must be placed close to the gauge IC and have short traces to both the  $V_{\text{DD}}$  pin and  $V_{\text{SS}}$ . This regulator must not be used to provide power for other devices in the system.
- It is required to have a capacitor of at least 1.0  $\mu\text{F}$  connect between the BAT pin and  $V_{\text{SS}}$  if the connection between the battery pack and the gauge BAT pin has the potential to pick up noise. The capacitor should be placed close to the gauge IC and have short traces to both the BAT pin and  $V_{\text{SS}}$ .
- If the external pullup resistors on the SCL and SDA lines will be disconnected from the host during low-power operation, it is recommended to use external 1-M $\Omega$  pulldown resistors to  $V_{\text{SS}}$  to avoid floating inputs to the I<sup>2</sup>C engine.
- The value of the SCL and SDA pullup resistors should take into consideration the pullup voltage and the bus capacitance. Some recommended values, assuming a bus capacitance of 10 pF, can be seen in [Table 1](#).

**Table 1. Recommended Values for SCL and SDA Pullup Resistors**

| VPU             | 1.8 V   |               | 3.3 V   |                |
|-----------------|---|---------------|---|----------------|
|                 | Range   | Typical       | Range   | Typical        |
| $R_{\text{PU}}$ | $400 \Omega \leq R_{\text{PU}} \leq 37.6 \text{ k}\Omega$ | 10 k $\Omega$ | $900 \Omega \leq R_{\text{PU}} \leq 29.2 \text{ k}\Omega$ | 5.1 k $\Omega$ |

- If the host is not using the GPOUT functionality, then it is recommended that GPOUT be connected to a GPIO of the host so that in the cases where the device is in SHUTDOWN, toggling GPOUT can wake the gauge from the SHUTDOWN state.
- If the battery pack thermistor is not connected to the BIN pin, the BIN pin should be pulled down to  $V_{\text{SS}}$  with a 10-k $\Omega$  resistor.
- The BIN pin should not be shorted directly to  $V_{\text{DD}}$  or  $V_{\text{SS}}$ .
- The actual device ground is pin B2 ( $V_{\text{SS}}$ ).
- The SRP and SRN pins should be Kelvin connected to the  $R_{\text{SENSE}}$  terminals. SRP to the battery pack side of  $R_{\text{SENSE}}$  and SRN to the system side of the  $R_{\text{SENSE}}$ .
- Kelvin connect the BAT pin to the battery PACKP terminal.

## 10.2 Layout Example

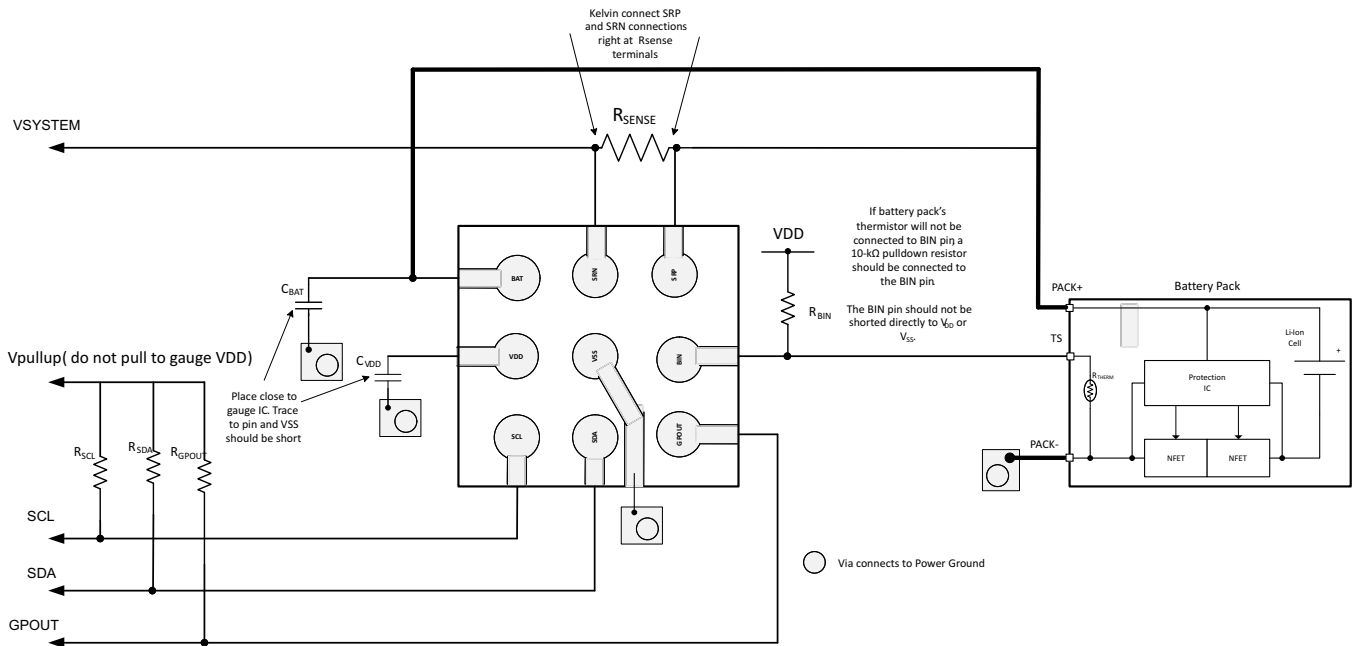

Figure 14. EVM Board Layout



## 11 Device and Documentation Support

### 11.1 Documentation Support

#### 11.1.1 Related Documentation

- *bq27220 Technical Reference Manual* ([SLUUBD4](#))
- *Quickstart Guide for bq27220* ([SLUUAP7](#))
- *Single Cell Gas Gauge Circuit Design* ([SLUA456](#))
- *Key Design Considerations for the bq27500 and bq27501* ([SLUA439](#))
- *ESD and RF Mitigation in Handheld Battery Electronics* ([SLUA460](#))

### 11.2 Community Resources

The following links connect to TI community resources. Linked contents are provided "AS IS" by the respective contributors. They do not constitute TI specifications and do not necessarily reflect TI's views; see TI's [Terms of Use](#).

**TI E2E™ Online Community** *TI's Engineer-to-Engineer (E2E) Community*. Created to foster collaboration among engineers. At [e2e.ti.com](#), you can ask questions, share knowledge, explore ideas and help solve problems with fellow engineers.

**Design Support** *TI's Design Support* Quickly find helpful E2E forums along with design support tools and contact information for technical support.

### 11.3 Trademarks

NanoFree, E2E are trademarks of Texas Instruments.

l<sup>2</sup>C is a trademark of NXP Semiconductors, N.V.

All other trademarks are the property of their respective owners.

### 11.4 Electrostatic Discharge Caution



This integrated circuit can be damaged by ESD. Texas Instruments recommends that all integrated circuits be handled with appropriate precautions. Failure to observe proper handling and installation procedures can cause damage.

ESD damage can range from subtle performance degradation to complete device failure. Precision integrated circuits may be more susceptible to damage because very small parametric changes could cause the device not to meet its published specifications.

### 11.5 Glossary

[SLYZ022](#) — *TI Glossary*.

This glossary lists and explains terms, acronyms, and definitions.

## 12 Mechanical, Packaging, and Orderable Information

The following pages include mechanical, packaging, and orderable information. This information is the most current data available for the designated devices. This data is subject to change without notice and revision of this document. For browser-based versions of this data sheet, refer to the left-hand navigation.

**PACKAGING INFORMATION**

| Orderable Device | Status<br>(1) | Package Type | Package Drawing | Pins | Package Qty | Eco Plan<br>(2)         | Lead/Ball Finish<br>(6) | MSL Peak Temp<br>(3) | Op Temp (°C) | Device Marking<br>(4/5) | Samples                 |
|------------------|---------------|--------------|-----------------|------|-------------|-------------------------|-------------------------|----------------------|--------------|-------------------------|-------------------------|
| BQ27220YZFR      | ACTIVE        | DSBGA        | YZF             | 9    | 3000        | Green (RoHS & no Sb/Br) | SNAGCU                  | Level-1-260C-UNLIM   | -40 to 85    | BQ27220                 | <a href="#">Samples</a> |
| BQ27220YZFT      | ACTIVE        | DSBGA        | YZF             | 9    | 250         | Green (RoHS & no Sb/Br) | SNAGCU                  | Level-1-260C-UNLIM   | -40 to 85    | BQ27220                 | <a href="#">Samples</a> |

(1) The marketing status values are defined as follows:

**ACTIVE:** Product device recommended for new designs.

**LIFEBUY:** TI has announced that the device will be discontinued, and a lifetime-buy period is in effect.

**NRND:** Not recommended for new designs. Device is in production to support existing customers, but TI does not recommend using this part in a new design.

**PREVIEW:** Device has been announced but is not in production. Samples may or may not be available.

**OBSOLETE:** TI has discontinued the production of the device.

(2) Eco Plan - The planned eco-friendly classification: Pb-Free (RoHS), Pb-Free (RoHS Exempt), or Green (RoHS & no Sb/Br) - please check <http://www.ti.com/productcontent> for the latest availability information and additional product content details.

**TBD:** The Pb-Free/Green conversion plan has not been defined.

**Pb-Free (RoHS):** TI's terms "Lead-Free" or "Pb-Free" mean semiconductor products that are compatible with the current RoHS requirements for all 6 substances, including the requirement that lead not exceed 0.1% by weight in homogeneous materials. Where designed to be soldered at high temperatures, TI Pb-Free products are suitable for use in specified lead-free processes.

**Pb-Free (RoHS Exempt):** This component has a RoHS exemption for either 1) lead-based flip-chip solder bumps used between the die and package, or 2) lead-based die adhesive used between the die and leadframe. The component is otherwise considered Pb-Free (RoHS compatible) as defined above.

**Green (RoHS & no Sb/Br):** TI defines "Green" to mean Pb-Free (RoHS compatible), and free of Bromine (Br) and Antimony (Sb) based flame retardants (Br or Sb do not exceed 0.1% by weight in homogeneous material)

(3) MSL, Peak Temp. - The Moisture Sensitivity Level rating according to the JEDEC industry standard classifications, and peak solder temperature.

(4) There may be additional marking, which relates to the logo, the lot trace code information, or the environmental category on the device.

(5) Multiple Device Markings will be inside parentheses. Only one Device Marking contained in parentheses and separated by a "~" will appear on a device. If a line is indented then it is a continuation of the previous line and the two combined represent the entire Device Marking for that device.

(6) Lead/Ball Finish - Orderable Devices may have multiple material finish options. Finish options are separated by a vertical ruled line. Lead/Ball Finish values may wrap to two lines if the finish value exceeds the maximum column width.

**Important Information and Disclaimer:** The information provided on this page represents TI's knowledge and belief as of the date that it is provided. TI bases its knowledge and belief on information provided by third parties, and makes no representation or warranty as to the accuracy of such information. Efforts are underway to better integrate information from third parties. TI has taken and continues to take reasonable steps to provide representative and accurate information but may not have conducted destructive testing or chemical analysis on incoming materials and chemicals. TI and TI suppliers consider certain information to be proprietary, and thus CAS numbers and other limited information may not be available for release.

In no event shall TI's liability arising out of such information exceed the total purchase price of the TI part(s) at issue in this document sold by TI to Customer on an annual basis.

## TAPE AND REEL INFORMATION



### QUADRANT ASSIGNMENTS FOR PIN 1 ORIENTATION IN TAPE



\*All dimensions are nominal

| Device      | Package Type | Package Drawing | Pins | SPQ  | Reel Diameter (mm) | Reel Width W1 (mm) | A0 (mm) | B0 (mm) | K0 (mm) | P1 (mm) | W (mm) | Pin1 Quadrant |
|-------------|--------------|-----------------|------|------|--------------------|--------------------|---------|---------|---------|---------|--------|---------------|
| BQ27220YZFR | DSBGA        | YZF             | 9    | 3000 | 180.0              | 8.4                | 1.78    | 1.78    | 0.69    | 4.0     | 8.0    | Q1            |
| BQ27220YZFT | DSBGA        | YZF             | 9    | 250  | 180.0              | 8.4                | 1.78    | 1.78    | 0.69    | 4.0     | 8.0    | Q1            |

**TAPE AND REEL BOX DIMENSIONS**

\*All dimensions are nominal

| Device      | Package Type | Package Drawing | Pins | SPQ  | Length (mm) | Width (mm) | Height (mm) |
|-------------|--------------|-----------------|------|------|-------------|------------|-------------|
| BQ27220YZFR | DSBGA        | YZF             | 9    | 3000 | 182.0       | 182.0      | 20.0        |
| BQ27220YZFT | DSBGA        | YZF             | 9    | 250  | 182.0       | 182.0      | 20.0        |

YZF (S-XBGA-N9)

DIE-SIZE BALL GRID ARRAY

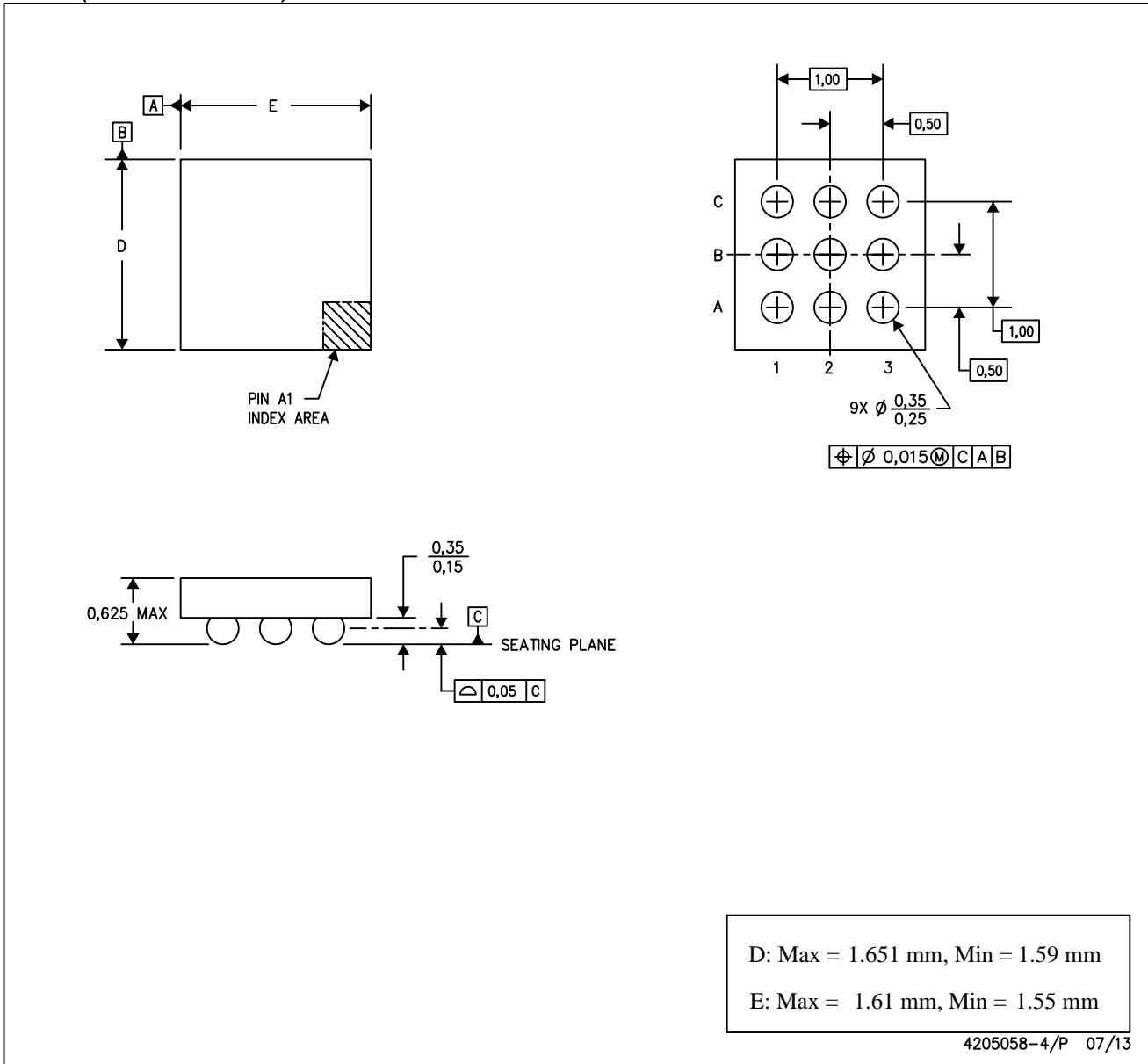

- NOTES: A. All linear dimensions are in millimeters. Dimensioning and tolerancing per ASME Y14.5M-1994.  
 B. This drawing is subject to change without notice.  
 C. NanoFree™ package configuration.

NanoFree is a trademark of Texas Instruments.

## IMPORTANT NOTICE

Texas Instruments Incorporated (TI) reserves the right to make corrections, enhancements, improvements and other changes to its semiconductor products and services per JESD46, latest issue, and to discontinue any product or service per JESD48, latest issue. Buyers should obtain the latest relevant information before placing orders and should verify that such information is current and complete.

TI's published terms of sale for semiconductor products (<http://www.ti.com/sc/docs/stdterms.htm>) apply to the sale of packaged integrated circuit products that TI has qualified and released to market. Additional terms may apply to the use or sale of other types of TI products and services.

Reproduction of significant portions of TI information in TI data sheets is permissible only if reproduction is without alteration and is accompanied by all associated warranties, conditions, limitations, and notices. TI is not responsible or liable for such reproduced documentation. Information of third parties may be subject to additional restrictions. Resale of TI products or services with statements different from or beyond the parameters stated by TI for that product or service voids all express and any implied warranties for the associated TI product or service and is an unfair and deceptive business practice. TI is not responsible or liable for any such statements.

Buyers and others who are developing systems that incorporate TI products (collectively, "Designers") understand and agree that Designers remain responsible for using their independent analysis, evaluation and judgment in designing their applications and that Designers have full and exclusive responsibility to assure the safety of Designers' applications and compliance of their applications (and of all TI products used in or for Designers' applications) with all applicable regulations, laws and other applicable requirements. Designer represents that, with respect to their applications, Designer has all the necessary expertise to create and implement safeguards that (1) anticipate dangerous consequences of failures, (2) monitor failures and their consequences, and (3) lessen the likelihood of failures that might cause harm and take appropriate actions. Designer agrees that prior to using or distributing any applications that include TI products, Designer will thoroughly test such applications and the functionality of such TI products as used in such applications.

TI's provision of technical, application or other design advice, quality characterization, reliability data or other services or information, including, but not limited to, reference designs and materials relating to evaluation modules, (collectively, "TI Resources") are intended to assist designers who are developing applications that incorporate TI products; by downloading, accessing or using TI Resources in any way, Designer (individually or, if Designer is acting on behalf of a company, Designer's company) agrees to use any particular TI Resource solely for this purpose and subject to the terms of this Notice.

TI's provision of TI Resources does not expand or otherwise alter TI's applicable published warranties or warranty disclaimers for TI products, and no additional obligations or liabilities arise from TI providing such TI Resources. TI reserves the right to make corrections, enhancements, improvements and other changes to its TI Resources. TI has not conducted any testing other than that specifically described in the published documentation for a particular TI Resource.

Designer is authorized to use, copy and modify any individual TI Resource only in connection with the development of applications that include the TI product(s) identified in such TI Resource. NO OTHER LICENSE, EXPRESS OR IMPLIED, BY ESTOPPEL OR OTHERWISE TO ANY OTHER TI INTELLECTUAL PROPERTY RIGHT, AND NO LICENSE TO ANY TECHNOLOGY OR INTELLECTUAL PROPERTY RIGHT OF TI OR ANY THIRD PARTY IS GRANTED HEREIN, including but not limited to any patent right, copyright, mask work right, or other intellectual property right relating to any combination, machine, or process in which TI products or services are used. Information regarding or referencing third-party products or services does not constitute a license to use such products or services, or a warranty or endorsement thereof. Use of TI Resources may require a license from a third party under the patents or other intellectual property of the third party, or a license from TI under the patents or other intellectual property of TI.

TI RESOURCES ARE PROVIDED "AS IS" AND WITH ALL FAULTS. TI DISCLAIMS ALL OTHER WARRANTIES OR REPRESENTATIONS, EXPRESS OR IMPLIED, REGARDING RESOURCES OR USE THEREOF, INCLUDING BUT NOT LIMITED TO ACCURACY OR COMPLETENESS, TITLE, ANY EPIDEMIC FAILURE WARRANTY AND ANY IMPLIED WARRANTIES OF MERCHANTABILITY, FITNESS FOR A PARTICULAR PURPOSE, AND NON-INFRINGEMENT OF ANY THIRD PARTY INTELLECTUAL PROPERTY RIGHTS. TI SHALL NOT BE LIABLE FOR AND SHALL NOT DEFEND OR INDEMNIFY DESIGNER AGAINST ANY CLAIM, INCLUDING BUT NOT LIMITED TO ANY INFRINGEMENT CLAIM THAT RELATES TO OR IS BASED ON ANY COMBINATION OF PRODUCTS EVEN IF DESCRIBED IN TI RESOURCES OR OTHERWISE. IN NO EVENT SHALL TI BE LIABLE FOR ANY ACTUAL, DIRECT, SPECIAL, COLLATERAL, INDIRECT, PUNITIVE, INCIDENTAL, CONSEQUENTIAL OR EXEMPLARY DAMAGES IN CONNECTION WITH OR ARISING OUT OF TI RESOURCES OR USE THEREOF, AND REGARDLESS OF WHETHER TI HAS BEEN ADVISED OF THE POSSIBILITY OF SUCH DAMAGES.

Unless TI has explicitly designated an individual product as meeting the requirements of a particular industry standard (e.g., ISO/TS 16949 and ISO 26262), TI is not responsible for any failure to meet such industry standard requirements.

Where TI specifically promotes products as facilitating functional safety or as compliant with industry functional safety standards, such products are intended to help enable customers to design and create their own applications that meet applicable functional safety standards and requirements. Using products in an application does not by itself establish any safety features in the application. Designers must ensure compliance with safety-related requirements and standards applicable to their applications. Designer may not use any TI products in life-critical medical equipment unless authorized officers of the parties have executed a special contract specifically governing such use. Life-critical medical equipment is medical equipment where failure of such equipment would cause serious bodily injury or death (e.g., life support, pacemakers, defibrillators, heart pumps, neurostimulators, and implantables). Such equipment includes, without limitation, all medical devices identified by the U.S. Food and Drug Administration as Class III devices and equivalent classifications outside the U.S.

TI may expressly designate certain products as completing a particular qualification (e.g., Q100, Military Grade, or Enhanced Product). Designers agree that it has the necessary expertise to select the product with the appropriate qualification designation for their applications and that proper product selection is at Designers' own risk. Designers are solely responsible for compliance with all legal and regulatory requirements in connection with such selection.

Designer will fully indemnify TI and its representatives against any damages, costs, losses, and/or liabilities arising out of Designer's non-compliance with the terms and provisions of this Notice.