

DRV8836 Dual Low-Voltage H-Bridge IC

1 Features

- Dual-H-Bridge Motor Driver
 - Capable of Driving Two DC Motors or One Stepper Motor
 - Low MOSFET On-Resistance: HS + LS 305 mΩ
- 1.5-A Maximum Drive Current Per H-Bridge
- Configure Bridges Parallel for 3-A Drive Current
- 2-V to 7-V Operating Supply Voltage
- Flexible PWM or PHASE/ENABLE Interface
- Low-Power Sleep Mode With 95-nA Maximum Supply Current
- Dedicated nSLEEP Input Pin
- Tiny 2.00-mm x 3.00-mm WSON Package

2 Applications

- Battery-Powered:
 - DSLR Lenses
 - Consumer Products
 - Toys
 - Robotics
 - Cameras
 - Medical Devices

3 Description

The DRV8836 provides an integrated motor driver solution for cameras, consumer products, toys, and other low-voltage or battery-powered motion control applications. The device has two H-bridge drivers, and can drive two DC motors or one stepper motor, as well as other devices like solenoids. The output driver block for each consists of N-channel power MOSFET configured as an H-bridge to drive the motor winding. An internal charge pump generates gate drive voltages.

The DRV8836 supplies up to 1.5-A of output current per H-bridge. It operates on a power supply voltage from 2 V to 7 V.

PHASE/ENABLE and IN/IN interfaces can be selected which are compatible with industry-standard devices. A low-power sleep mode is provided which turns off all unnecessary logic to provide a very low current state.

Internal shutdown functions are provided for overcurrent protection, short-circuit protection, undervoltage lockout, and overtemperature.

The DRV8836 is packaged in a tiny 12-pin WSON package (Eco-friendly: RoHS and no Sb/Br).

Device Information⁽¹⁾

PART NUMBER	PACKAGE	BODY SIZE (NOM)
DRV8836	WSON (12)	2.00 mm x 3.00 mm

(1) For all available packages, see the orderable addendum at the end of the datasheet.

Simplified Schematic

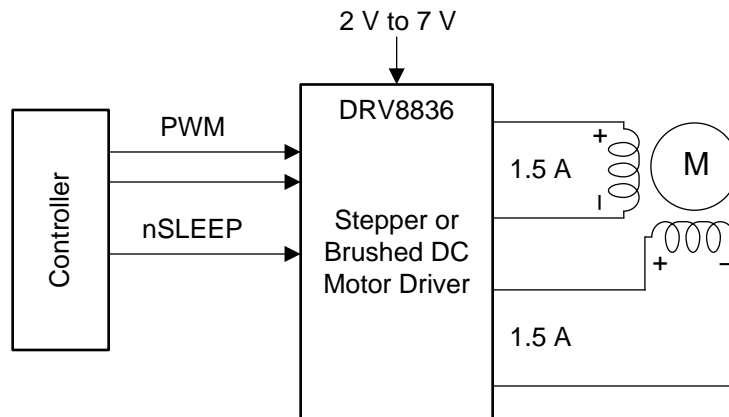

Copyright © 2016, Texas Instruments Incorporated



Table of Contents

1 Features	1	7.4 Device Functional Modes.....	9
2 Applications	1	8 Application and Implementation	11
3 Description	1	8.1 Application Information.....	11
4 Revision History	2	8.2 Typical Application	11
5 Pin Configuration and Functions	3	9 Power Supply Recommendations	13
6 Specifications	4	9.1 Bulk Capacitance	13
6.1 Absolute Maximum Ratings	4	10 Layout	13
6.2 ESD Ratings.....	4	10.1 Layout Guidelines	13
6.3 Recommended Operating Conditions.....	4	10.2 Layout Example	14
6.4 Thermal Information	4	10.3 Thermal Considerations.....	14
6.5 Electrical Characteristics.....	5	11 Device and Documentation Support	16
6.6 Timing Requirements	6	11.1 Documentation Support	16
6.7 Typical Characteristics	7	11.2 Community Resources.....	16
7 Detailed Description	8	11.3 Trademarks	16
7.1 Overview	8	11.4 Electrostatic Discharge Caution.....	16
7.2 Functional Block Diagram	8	11.5 Glossary	16
7.3 Feature Description.....	9	12 Mechanical, Packaging, and Orderable Information	16

4 Revision History

NOTE: Page numbers for previous revisions may differ from page numbers in the current version.

Changes from Revision C (December 2015) to Revision D	Page
• Deleted nFAULT from the <i>Simplified Schematic</i> in the <i>Description</i> section	1

Changes from Revision B (January 2014) to Revision C	Page
• Added <i>ESD Ratings</i> table, <i>Feature Description</i> section, <i>Device Functional Modes</i> , <i>Application and Implementation</i> section, <i>Power Supply Recommendations</i> section, <i>Layout</i> section, <i>Device and Documentation Support</i> section, and <i>Mechanical, Packaging, and Orderable Information</i> section	1

Changes from Revision A (September 2013) to Revision B	Page
• Added t_{OCR} and t_{DEAD} parameters to <i>Electrical Characteristics</i>	5

5 Pin Configuration and Functions

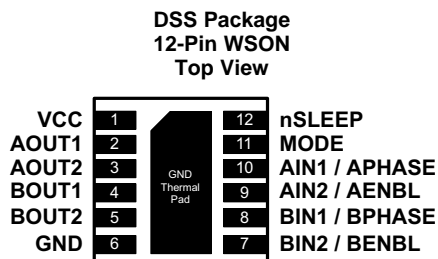

Pin Functions

PIN		I/O ⁽¹⁾	DESCRIPTION	EXTERNAL COMPONENTS OR CONNECTIONS
NAME	NO.			
POWER AND GROUND				
GND, Thermal pad	6	—	Device ground	
VCC	1	—	Device and motor supply	Bypass to GND with a 0.1- μ F (minimum) ceramic capacitor
CONTROL				
AIN1/APHASE	10	I	Bridge A input 1/PHASE input	IN/IN mode: Logic high sets AOUT1 high PH/EN mode: Sets direction of H-bridge A Internal pulldown resistor
AIN2/AENBL	9	I	Bridge A input 2/ENABLE input	IN/IN mode: Logic high sets AOUT2 high PH/EN mode: Logic high enables H-bridge A Internal pulldown resistor
BIN1/BPHASE	8	I	Bridge B input 1/PHASE input	IN/IN mode: Logic high sets BOUT1 high PH/EN mode: Sets direction of H-bridge B Internal pulldown resistor
BIN2/BENBL	7	I	Bridge B input 2/ENABLE input	IN/IN mode: Logic high sets BOUT2 high PH/EN mode: Logic high enables H-bridge B Internal pulldown resistor
MODE	11	I	Input mode select	Logic low selects IN/IN mode Logic high selects PH/EN mode Internal pulldown resistor
nSLEEP	12	I	Sleep input	Active low places part in low-power sleep state Internal pulldown resistor
OUTPUT				
AOUT1	2	O	Bridge A output 1	Connect to motor winding A
AOUT2	3	O	Bridge A output 2	
BOUT1	4	O	Bridge B output 1	Connect to motor winding B
BOUT2	5	O	Bridge B output 2	

(1) Directions: I = input, O = output, OZ = tri-state output, OD = open-drain output, IO = input/output.

6 Specifications

6.1 Absolute Maximum Ratings⁽¹⁾⁽²⁾

	MIN	MAX	UNIT
Power supply voltage, VCC	-0.3	7	V
Digital input pin voltage	-0.5	VCC + 0.5	V
Peak motor drive output current	Internally limited		A
Continuous motor drive output current per H-bridge ⁽³⁾	-1.5	1.5	A
T _J Operating junction temperature	-40	150	°C
T _{stg} Storage temperature	-60	150	°C

- (1) Stresses beyond those listed under *Absolute Maximum Ratings* may cause permanent damage to the device. These are stress ratings only, which do not imply functional operation of the device at these or any other conditions beyond those indicated under *Recommended Operating Conditions*. Exposure to absolute-maximum-rated conditions for extended periods may affect device reliability.
- (2) All voltage values pertain to network ground terminal.
- (3) Power dissipation and thermal limits must be observed.

6.2 ESD Ratings

	VALUE	UNIT
V _(ESD) Electrostatic discharge	Human-body model (HBM), per ANSI/ESDA/JEDEC JS-001 ⁽¹⁾	±2000
	Charged-device model (CDM), per JEDEC specification JESD22-C101 ⁽²⁾	±1500

- (1) JEDEC document JEP155 states that 500-V HBM allows safe manufacturing with a standard ESD control process.
- (2) JEDEC document JEP157 states that 250-V CDM allows safe manufacturing with a standard ESD control process.

6.3 Recommended Operating Conditions

T_A = 25°C (unless otherwise noted)

	MIN	MAX	UNIT
V _{CC} Device power supply voltage	2	7	V
V _{IN} Logic level input voltage	0	V _{CC}	V
I _{OUT} H-bridge output current ⁽¹⁾	0	1.5	A
f _{PWM} Externally applied PWM frequency	0	250	kHz

- (1) Power dissipation and thermal limits must be observed.

6.4 Thermal Information

THERMAL METRIC ⁽¹⁾	DRV8836	UNIT
	DSS (WSON)	
	12 PINS	
R _{θJA} Junction-to-ambient thermal resistance	50.4	°C/W
R _{θJC(top)} Junction-to-case (top) thermal resistance	58	°C/W
R _{θJB} Junction-to-board thermal resistance	19.9	°C/W
ψ _{JT} Junction-to-top characterization parameter	0.9	°C/W
ψ _{JB} Junction-to-board characterization parameter	20	°C/W
R _{θJC(bot)} Junction-to-case (bottom) thermal resistance	6.9	°C/W

- (1) For more information about traditional and new thermal metrics, see the *Semiconductor and IC Package Thermal Metrics* application report, SPRA953.

6.5 Electrical Characteristics

 $T_A = 25^\circ\text{C}$, $V_{CC} = 5\text{ V}$ (unless otherwise noted)

PARAMETER		TEST CONDITIONS	MIN	TYP	MAX	UNIT
POWER SUPPLY						
I_{VCC}	VCC operating supply current	$f_{PWM} = 50\text{ kHz}$, no load		1.7	2.5	mA
I_{CCQ}	VCC sleep mode supply current	$nSLEEP = 0\text{ V}$, all inputs 0 V		40	95	nA
		$V_{CC} = 3\text{ V}$, $nSLEEP = 0\text{ V}$, all inputs 0 V		10		
V_{UVLO}	VCC undervoltage lockout voltage	V_{CC} rising			2	V
		V_{CC} falling			1.9	
LOGIC-LEVEL INPUTS						
V_{IL}	Input low voltage				$0.25 \times V_{CC}$	V
V_{IH}	Input high voltage		$0.5 \times V_{CC}$			V
I_{IL}	Input low current	$V_{IN} = 0$	-5		5	μA
I_{IH}	Input high current	$V_{IN} = 3.3\text{ V}$			50	μA
R_{PD}	Pulldown resistance			100		k Ω
H-BRIDGE FETS						
$R_{DS(ON)}$	HS + LS FET on resistance	$V_{CC} = 3\text{ V}$, $I_O = 800\text{ mA}$, $T_J = 25^\circ\text{C}$		370	420	m Ω
		$V_{CC} = 5\text{ V}$, $I_O = 800\text{ mA}$, $T_J = 25^\circ\text{C}$		305	355	
I_{OFF}	OFF-state leakage current				± 200	nA
PROTECTION CIRCUITS						
I_{OCP}	Overcurrent protection trip level		1.6		3.5	A
t_{DEG}	Overcurrent deglitch time			1		μs
t_{OCR}	Overcurrent protection retry time			1		ms
t_{DEAD}	Output dead time			100		ns
t_{TSD}	Thermal shutdown temperature	Die temperature	150	160	180	$^\circ\text{C}$

6.6 Timing Requirements⁽¹⁾

T_A = 25°C, V_{CC} = 5 V, R_L = 20 Ω

NO.		MIN	MAX	UNIT
1	t ₁		210	ns
2	t ₂		150	ns
3	t ₃		150	ns
4	t ₄		210	ns
5	t ₅		150	ns
6	t ₆		150	ns
7	t ₇		210	ns
8	t ₈		210	ns
9	t ₉		125	ns
10	t ₁₀		125	ns
11	t _R	20	188	ns
12	t _F	8	30	ns

(1) Not production tested – ensured by design

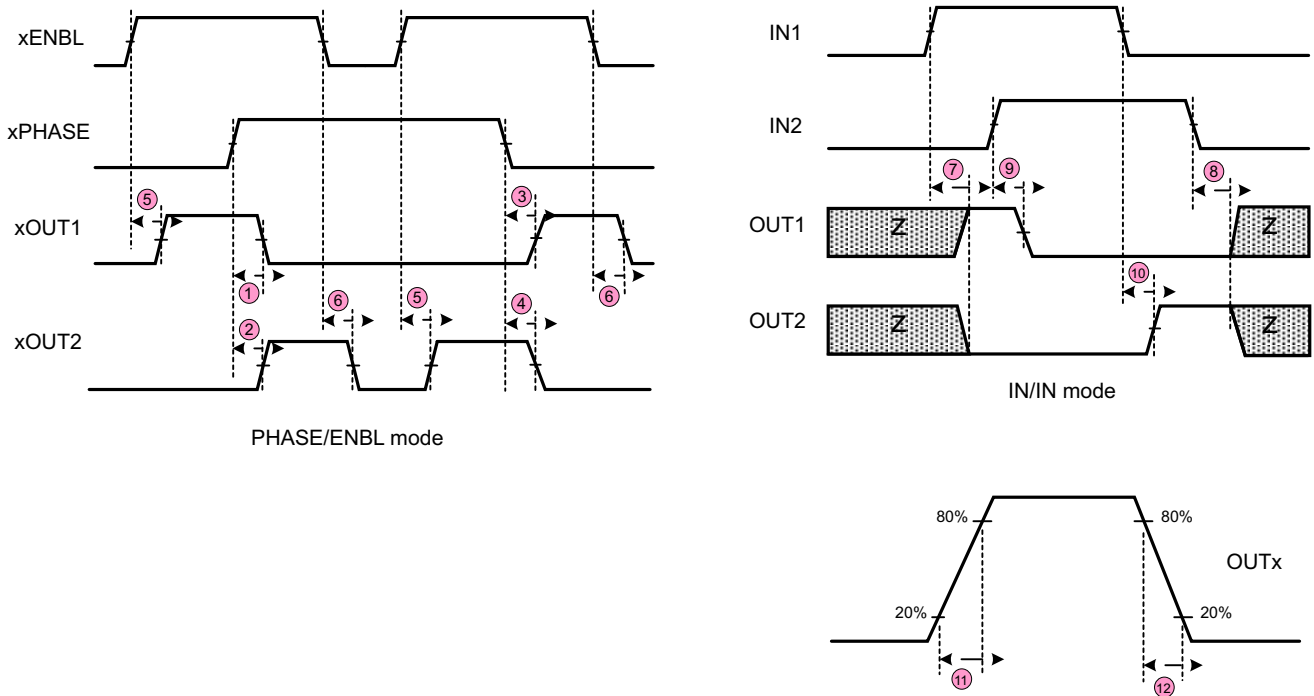
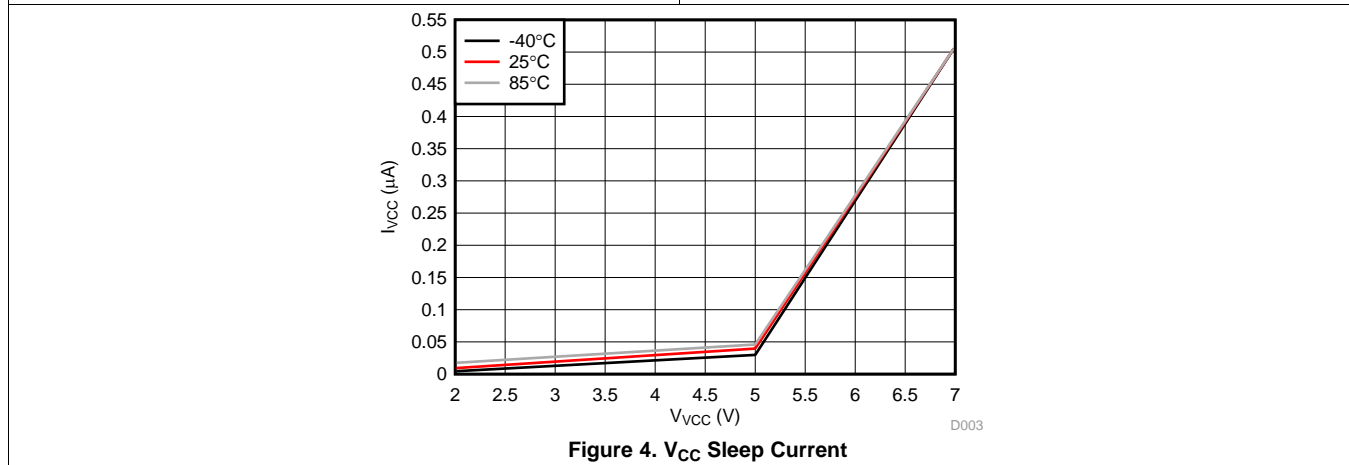
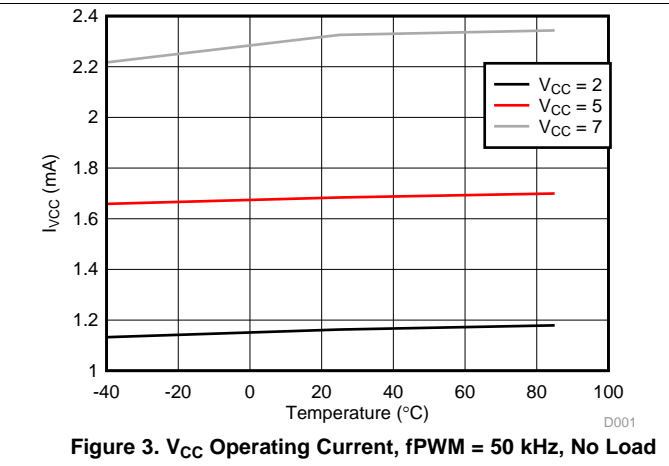
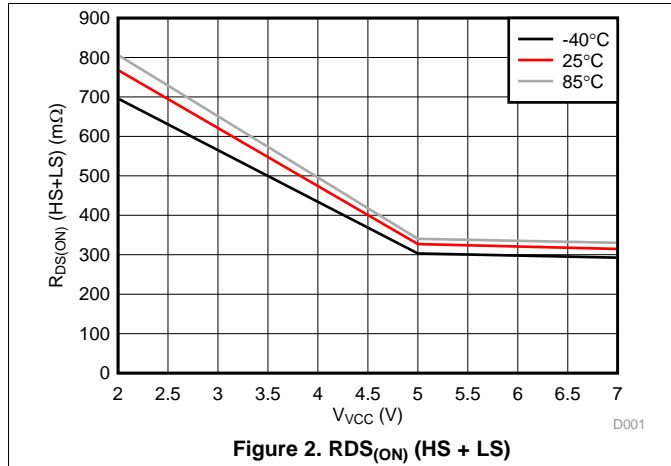

Figure 1. Timing Requirements

6.7 Typical Characteristics



7 Detailed Description

7.1 Overview

The DRV8836 is an integrated motor driver solution used for brushed motor control. The device integrates two H-bridges, and can drive two DC motor or one stepper motor. The output driver block for each H-bridge consists of N-channel power MOSFETs. An internal charge pump generates the gate drive voltages. Protection features include overcurrent protection, short-circuit protection, undervoltage lockout, and overtemperature protection.

The bridges connect in parallel for additional current capability.

The mode pin allows selection of either a PHASE/ENABLE or IN/IN interface.

7.2 Functional Block Diagram

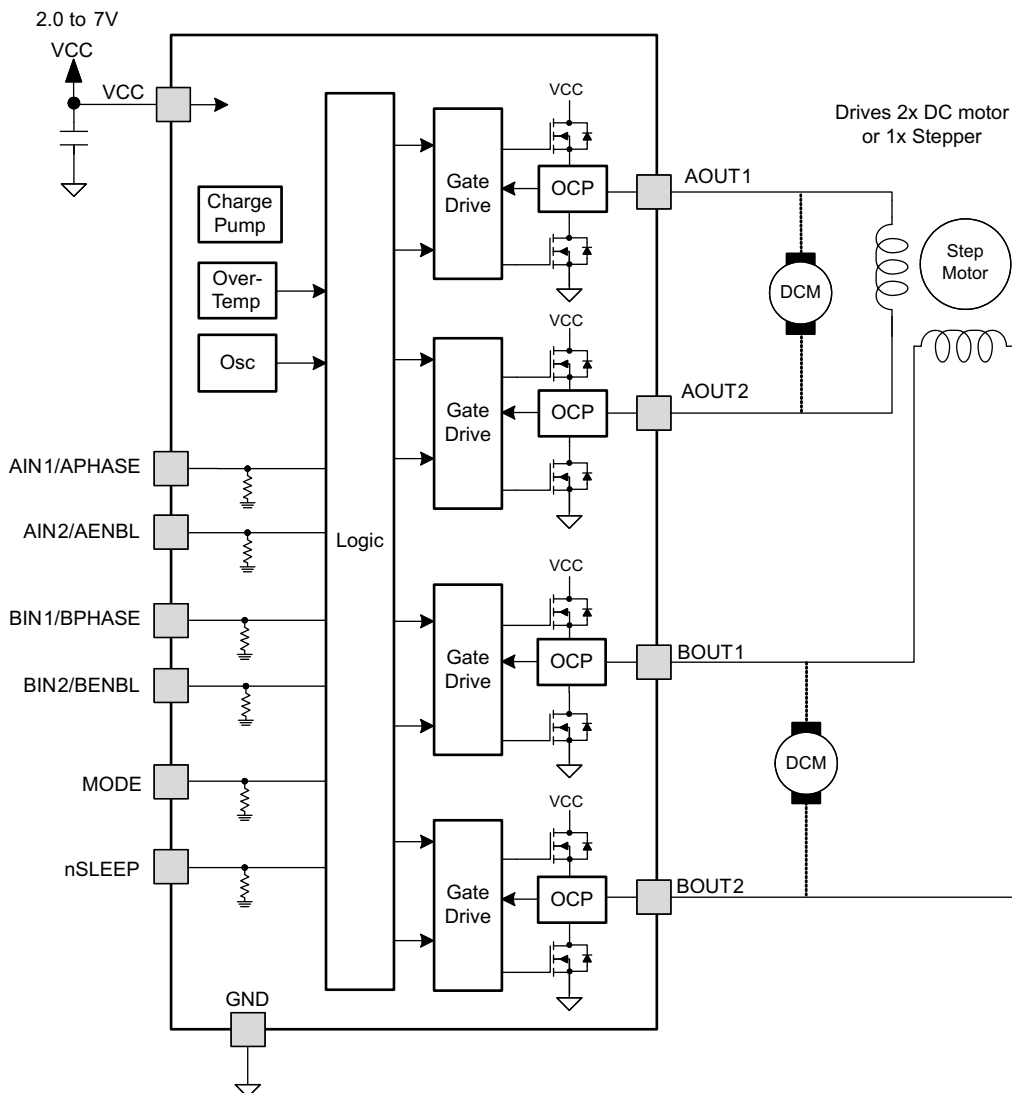

Copyright © 2016, Texas Instruments Incorporated

7.3 Feature Description

7.3.1 Sleep Mode

If the nSLEEP pin enters a logic-low state, the DRV8836 enters a low-power sleep mode. In this state all unnecessary internal circuitry is powered down.

7.3.2 Power Supplies and Input Pins

There is a weak pulldown resistor (approximately 100 kΩ) to ground on the input pins.

7.3.3 Protection Circuits

The DRV8836 is fully protected against undervoltage, overcurrent, and overtemperature events.

7.3.3.1 Overcurrent Protection (OCP)

An analog current limit circuit on each FET limits the current through the FET by removing the gate drive. If this analog current limit persists for longer than the OCP time, all FETs in the H-bridge disable. After approximately 1 ms, the bridge re-enables automatically.

Overcurrent conditions on both high and low side devices, like a short to ground, supply, or across the motor winding results in an overcurrent shutdown.

7.3.3.2 Thermal Shutdown (TSD)

If the die temperature exceeds safe limits, all FETs in the H-bridge disable. Once the die temperature has fallen to a safe level operation automatically resumes.

7.3.3.3 Undervoltage Lockout (UVLO)

If at any time the voltage on the VCC pins falls below the undervoltage lockout threshold voltage, all circuitry in the device disables, and internal logic resets. Operation resumes when VCC rises above the UVLO threshold.

Table 1. Device Protection

FAULT	CONDITION	ERROR REPORT	H-BRIDGE	INTERNAL CIRCUITS	RECOVERY
VCC undervoltage (UVLO)	$VCC < VUVLO$	None	Disabled	Disabled	$VCC > VUVLO$
Overcurrent (OCP)	$IOUT > IOCP$	None	Disabled	Operating	tOCR
Thermal shutdown (TSD)	$TJ > TTSD$	None	Disabled	Operating	$TJ < TTSD - THYS$

7.4 Device Functional Modes

The DRV8836 is active when the nSLEEP pin is set to a logic high. When in sleep mode, the H-bridge FETs disable (Hi-Z).

Table 2. Device Operating Modes

OPERATING MODE	CONDITION	H-BRIDGE	INTERNAL CIRCUITS
Operating	nSLEEP high	Operating	Operating
Sleep mode	nSLEEP low	Disabled	Disabled
Fault encountered	Any fault condition met	Disabled	See Table 1

7.4.1 Bridge Control

Two control modes are available in the DRV8836: IN/IN mode and PHASE/ENABLE mode. IN/IN mode is selected if the MODE pin is driven low or left unconnected; PHASE/ENABLE mode is selected if the MODE pin is driven to logic high. The following tables show the logic for these modes.

Table 3. IN/IN Mode

MODE	xIN1	xIN2	xOUT1	xOUT2	FUNCTION (DC MOTOR)
0	0	0	Z	Z	Coast
0	0	1	L	H	Reverse
0	1	0	H	L	Forward
0	1	1	L	L	Brake

Table 4. PHASE/ENABLE Mode

MODE	xENABLE	xPHASE	xOUT1	xOUT2	FUNCTION (DC MOTOR)
1	0	X	L	L	Brake
1	1	1	L	H	Reverse
1	1	0	H	L	Forward

8 Application and Implementation

NOTE

The information in the following applications sections is not part of the TI component specification, and TI does not warrant its accuracy or completeness. TI's customers are responsible for determining suitability of components for their purposes. Customers should validate and test their design implementation to confirm system functionality.

8.1 Application Information

The DRV8836 is used in one or two motor control applications. When configured in parallel, the DRV8836 provides double the current to one motor.

8.2 Typical Application

The two H-bridges in the DRV8836 can be connected in parallel for double the current of a single H-bridge. [Figure 5](#) shows the connections.

The following design is a common application of the DRV8836.

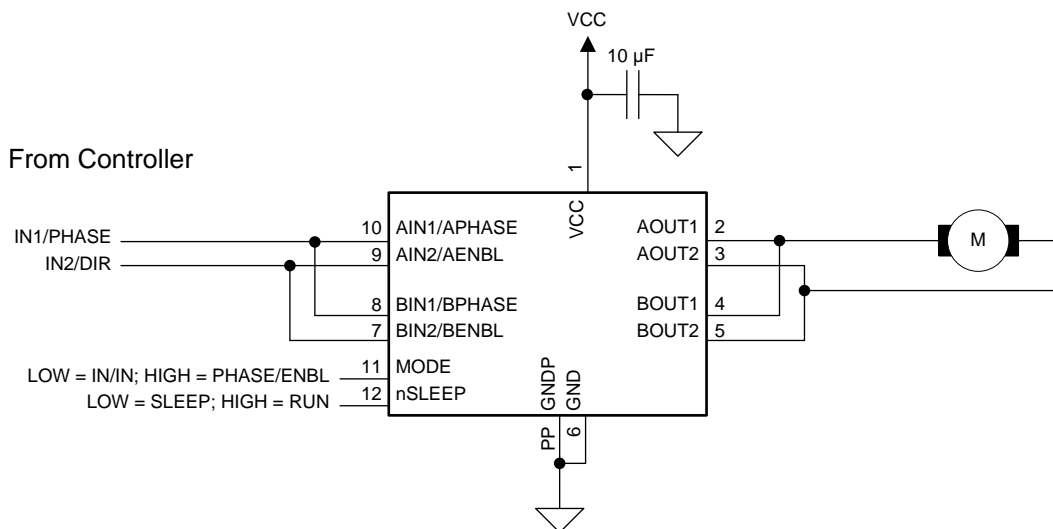

Copyright © 2016, Texas Instruments Incorporated

Figure 5. Parallel Mode Connections

8.2.1 Design Requirements

The design requirements are shown in [Table 5](#).

Table 5. Design Requirements

DESIGN PARAMETER	REFERENCE	EXAMPLE VALUE
Motor voltage	VCC	4 V
Motor RMS current	IRMS	0.3 A
Motor startup current	ISTART	0.6 A
Motor current trip point	ILIMIT	0.5 A

8.2.2 Detailed Design Procedure

The following design procedure can be used to configure the DRV8836 in a brushed motor application.

8.2.2.1 Motor Voltage

The appropriate motor voltage depends on the ratings of the motor selected and the desired RPM. A higher voltage spins a brushed DC motor faster with the same PWM duty cycle applied to the power FETs. A higher voltage also increases the rate of current change through the inductive motor windings.

8.2.2.2 Low-Power Operation

When entering sleep mode, TI recommends setting all inputs as a logic low to minimize system power.

8.2.3 Application Curve

The following scope captures motor startup as VCC ramps from 0 V to 6 V. Channel 1 is V_{CC}, and Channel 4 is the motor current of an unloaded motor during startup. The motor used is a NMB Technologies Corporation OOB7PA12C, PPN7PA12C1. As V_{CC} ramps the current in the motor increases until the motor speed builds up. The motor current then reduces for normal operation.

Inputs are set as follows:

- Mode: IN/IN
- AIN1: High
- AIN2: Low

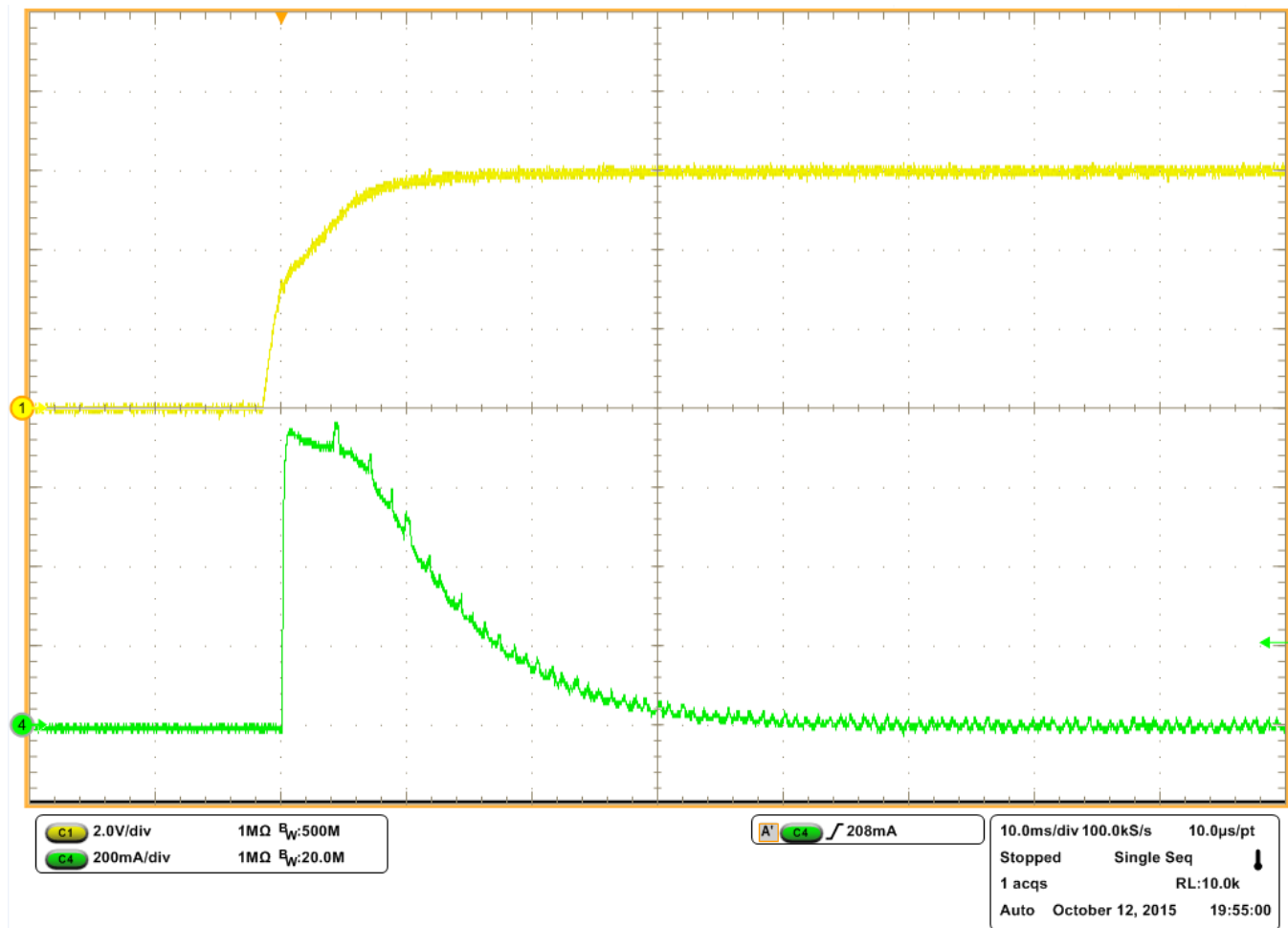

Figure 6. Motor Startup With No Load

9 Power Supply Recommendations

9.1 Bulk Capacitance

The appropriate local bulk capacitance is an important factor in motor drive system design. More bulk capacitance is generally beneficial but may increase costs and physical size.

The amount of local capacitance needed depends on a variety of factors, including:

- The highest current required by the motor system
- The power supply's capacitance and ability to source current
- The amount of parasitic inductance between the power supply and motor system
- The acceptable voltage ripple
- The type of motor used (brushed DC, brushless DC, stepper)
- The motor braking method

The inductance between the power supply and motor drive system limits the rate current changes from the power supply. If the local bulk capacitance is too small, the system responds to excessive current demands or dumps from the motor with a change in voltage. When adequate bulk capacitance is used, the motor voltage remains stable and high current can be quickly supplied.

The datasheet provides a recommended value, but system-level testing is required to determine the appropriate sized bulk capacitor.

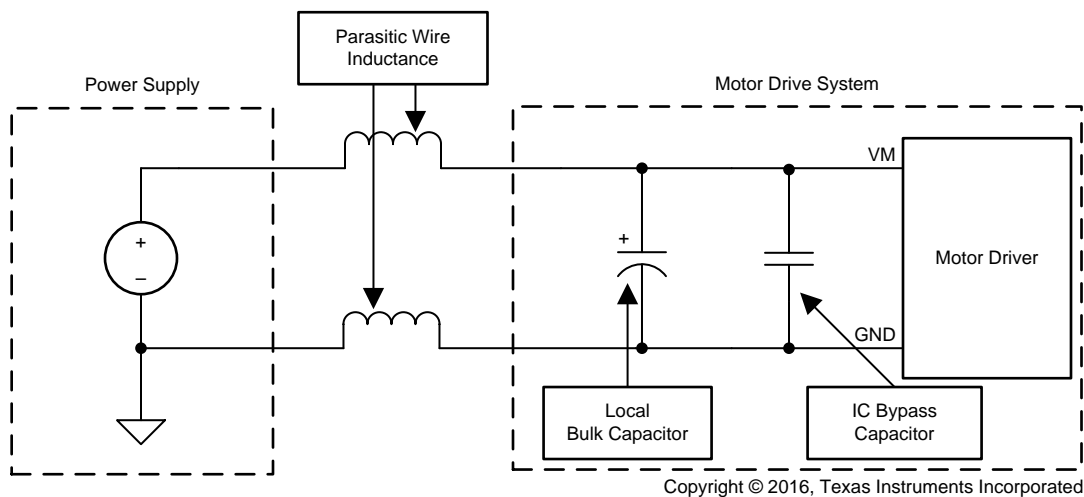

Figure 7. Bulk Capacitor

10 Layout

10.1 Layout Guidelines

The VCC pin should be bypassed to GND using low-ESR ceramic bypass capacitors with a recommended value of 0.1- μ F rated for VCC. This capacitor should be placed as close to the VCC pin as possible with a thick trace or ground plane connection to the device GND pin.

The VCC pin must bypass to ground using an appropriate bulk capacitor. This component may be an electrolytic and should be located close to the DRV8836.

10.2 Layout Example

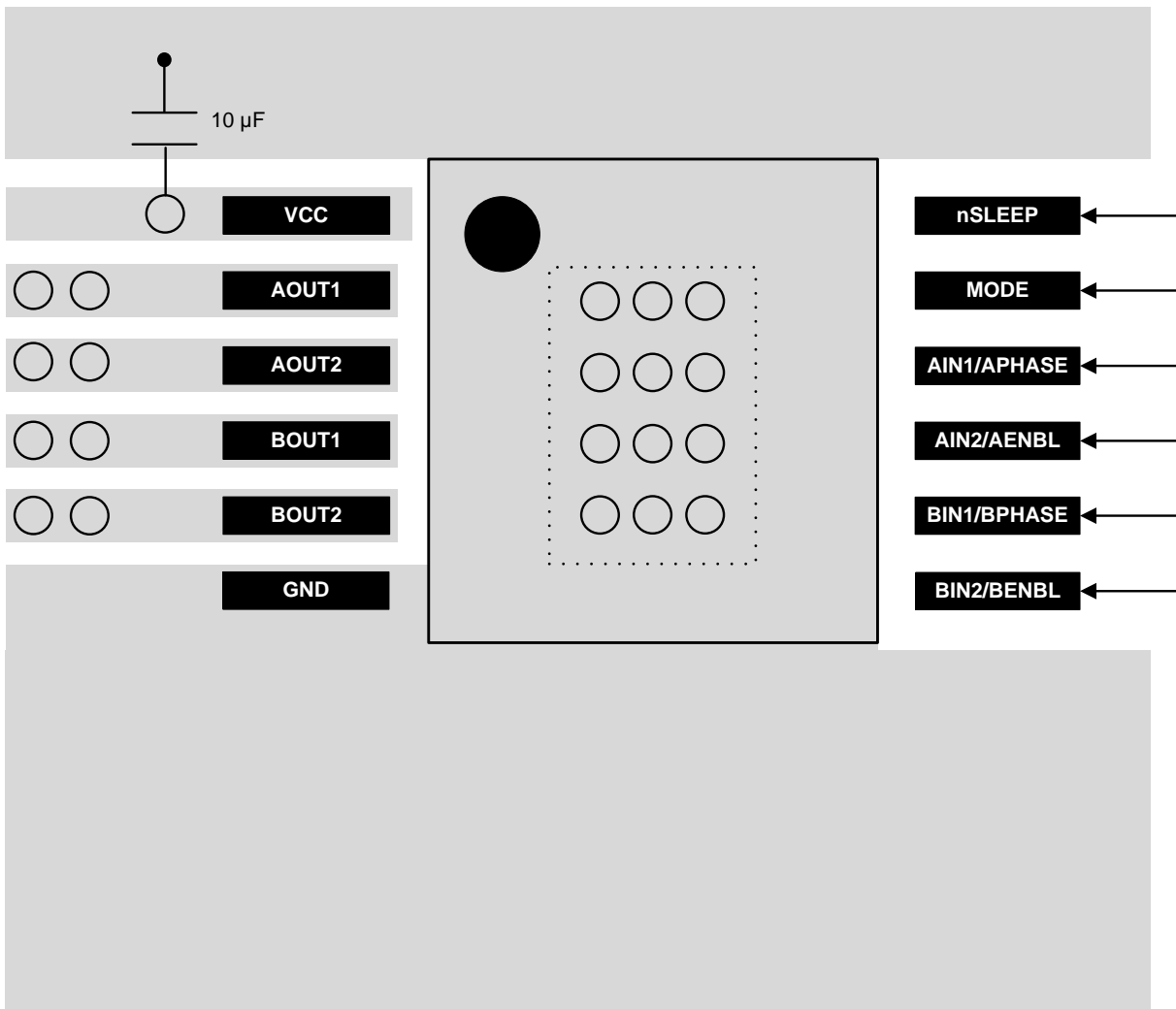

Figure 8. Layout Recommendation

10.3 Thermal Considerations

The DRV8836 has thermal shutdown (TSD) as described in [Thermal Shutdown \(TSD\)](#). If the die temperature exceeds approximately 150°C, the device disables until the temperature drops to a safe level.

Any tendency of the device to enter thermal shutdown is an indication of either excessive power dissipation, insufficient heatsinking, or an ambient temperature that is too high.

10.3.1 Power Dissipation

The power dissipated in the output FET resistance or $R_{DS(on)}$ dominates the power dissipation in the DRV8836. The average power dissipation when running both H-bridges can be roughly estimated by [Equation 1](#):

$$P_{TOT} = 2 \times R_{DS(on)} \times (I_{OUT(RMS)})^2$$

where

- P_{TOT} is the total power dissipation, $R_{DS(on)}$ is the resistance of the HS plus LS FETs, and $I_{OUT(RMS)}$ is the RMS output current being applied to each winding. $I_{OUT(RMS)}$ is equal to approximately 0.7x the full-scale output current setting. The factor of 2 comes from the fact that there are two H-bridges. (1)

The maximum amount of power dissipated in the device is dependent on ambient temperature and heatsinking.

Thermal Considerations (continued)

NOTE

$R_{DS(ON)}$ increases with temperature. As the device heats, the power dissipation increases. This must be taken into consideration when sizing the heatsink.

10.3.2 Heatsinking

The PowerPAD™ package uses an exposed pad to remove heat from the device. For proper operation, this pad must be thermally connected to copper on the PCB to dissipate heat. On a multi-layer PCB with a ground plane, this can be accomplished by adding a number of vias to connect the thermal pad to the ground plane. On PCBs without internal planes, copper area can be added on either side of the PCB to dissipate heat. If the copper area is on the opposite side of the PCB from the device, thermal vias are used to transfer the heat between top and bottom layers.

For more information on PCB design, refer to TI application report [SLMA002](#), *PowerPAD™ Thermally Enhanced Package*, and TI application brief [SLMA004](#), *PowerPAD™ Made Easy*, available at www.ti.com.

In general, the more copper area that can be provided, the more power can be dissipated.

11 Device and Documentation Support

11.1 Documentation Support

11.1.1 Related Documentation

For related documentation see the following:

- *Calculating Motor Driver Power Dissipation*, [SLVA504](#)
- *DRV8835/DRV8836 Evaluation Module*, [SLVU694](#)
- *Understanding Motor Driver Current Ratings*, [SLVA505](#)

11.2 Community Resources

The following links connect to TI community resources. Linked contents are provided "AS IS" by the respective contributors. They do not constitute TI specifications and do not necessarily reflect TI's views; see TI's [Terms of Use](#).

TI E2E™ Online Community *TI's Engineer-to-Engineer (E2E) Community*. Created to foster collaboration among engineers. At e2e.ti.com, you can ask questions, share knowledge, explore ideas and help solve problems with fellow engineers.

Design Support *TI's Design Support* Quickly find helpful E2E forums along with design support tools and contact information for technical support.

11.3 Trademarks

PowerPAD, E2E are trademarks of Texas Instruments.
All other trademarks are the property of their respective owners.

11.4 Electrostatic Discharge Caution



These devices have limited built-in ESD protection. The leads should be shorted together or the device placed in conductive foam during storage or handling to prevent electrostatic damage to the MOS gates.

11.5 Glossary

[SLYZ022](#) — *TI Glossary*.

This glossary lists and explains terms, acronyms, and definitions.

12 Mechanical, Packaging, and Orderable Information

The following pages include mechanical, packaging, and orderable information. This information is the most current data available for the designated devices. This data is subject to change without notice and revision of this document. For browser-based versions of this data sheet, refer to the left-hand navigation.

PACKAGING INFORMATION

Orderable Device	Status (1)	Package Type	Package Drawing	Pins	Package Qty	Eco Plan (2)	Lead/Ball Finish (6)	MSL Peak Temp (3)	Op Temp (°C)	Device Marking (4/5)	Samples
DRV8836DSSR	ACTIVE	WSON	DSS	12	3000	Green (RoHS & no Sb/Br)	CU NIPDAU	Level-2-260C-1 YEAR	-40 to 85	836	Samples

(1) The marketing status values are defined as follows:

ACTIVE: Product device recommended for new designs.

LIFEBUY: TI has announced that the device will be discontinued, and a lifetime-buy period is in effect.

NRND: Not recommended for new designs. Device is in production to support existing customers, but TI does not recommend using this part in a new design.

PREVIEW: Device has been announced but is not in production. Samples may or may not be available.

OBSELETE: TI has discontinued the production of the device.

(2) Eco Plan - The planned eco-friendly classification: Pb-Free (RoHS), Pb-Free (RoHS Exempt), or Green (RoHS & no Sb/Br) - please check <http://www.ti.com/productcontent> for the latest availability information and additional product content details.

TBD: The Pb-Free/Green conversion plan has not been defined.

Pb-Free (RoHS): TI's terms "Lead-Free" or "Pb-Free" mean semiconductor products that are compatible with the current RoHS requirements for all 6 substances, including the requirement that lead not exceed 0.1% by weight in homogeneous materials. Where designed to be soldered at high temperatures, TI Pb-Free products are suitable for use in specified lead-free processes.

Pb-Free (RoHS Exempt): This component has a RoHS exemption for either 1) lead-based flip-chip solder bumps used between the die and package, or 2) lead-based die adhesive used between the die and leadframe. The component is otherwise considered Pb-Free (RoHS compatible) as defined above.

Green (RoHS & no Sb/Br): TI defines "Green" to mean Pb-Free (RoHS compatible), and free of Bromine (Br) and Antimony (Sb) based flame retardants (Br or Sb do not exceed 0.1% by weight in homogeneous material)

(3) MSL, Peak Temp. - The Moisture Sensitivity Level rating according to the JEDEC industry standard classifications, and peak solder temperature.

(4) There may be additional marking, which relates to the logo, the lot trace code information, or the environmental category on the device.

(5) Multiple Device Markings will be inside parentheses. Only one Device Marking contained in parentheses and separated by a "~" will appear on a device. If a line is indented then it is a continuation of the previous line and the two combined represent the entire Device Marking for that device.

(6) Lead/Ball Finish - Orderable Devices may have multiple material finish options. Finish options are separated by a vertical ruled line. Lead/Ball Finish values may wrap to two lines if the finish value exceeds the maximum column width.

Important Information and Disclaimer:The information provided on this page represents TI's knowledge and belief as of the date that it is provided. TI bases its knowledge and belief on information provided by third parties, and makes no representation or warranty as to the accuracy of such information. Efforts are underway to better integrate information from third parties. TI has taken and continues to take reasonable steps to provide representative and accurate information but may not have conducted destructive testing or chemical analysis on incoming materials and chemicals. TI and TI suppliers consider certain information to be proprietary, and thus CAS numbers and other limited information may not be available for release.

In no event shall TI's liability arising out of such information exceed the total purchase price of the TI part(s) at issue in this document sold by TI to Customer on an annual basis.

TAPE AND REEL INFORMATION



QUADRANT ASSIGNMENTS FOR PIN 1 ORIENTATION IN TAPE



*All dimensions are nominal

Device	Package Type	Package Drawing	Pins	SPQ	Reel Diameter (mm)	Reel Width W1 (mm)	A0 (mm)	B0 (mm)	K0 (mm)	P1 (mm)	W (mm)	Pin1 Quadrant
DRV8836DSSR	WSON	DSS	12	3000	180.0	8.4	2.25	3.25	1.05	4.0	8.0	Q1

TAPE AND REEL BOX DIMENSIONS



*All dimensions are nominal

Device	Package Type	Package Drawing	Pins	SPQ	Length (mm)	Width (mm)	Height (mm)
DRV8836DSSR	WSON	DSS	12	3000	210.0	185.0	35.0

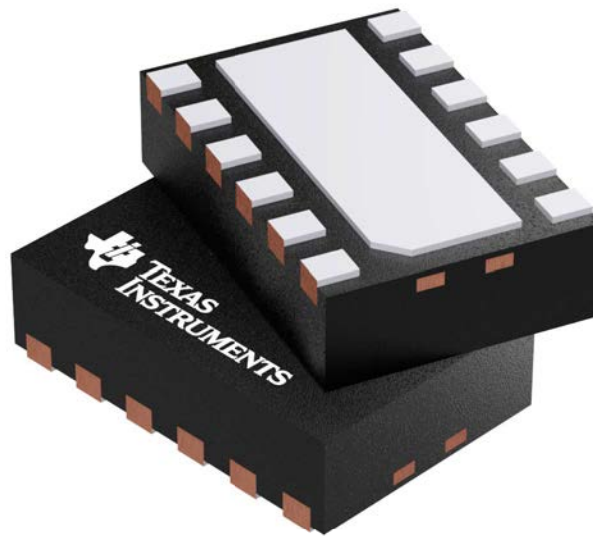

Images above are just a representation of the package family, actual package may vary.
Refer to the product data sheet for package details.

DSS0012A

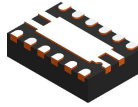

PACKAGE OUTLINE

WSON - 0.8 mm max height

PLASTIC SMALL OUTLINE - NO LEAD

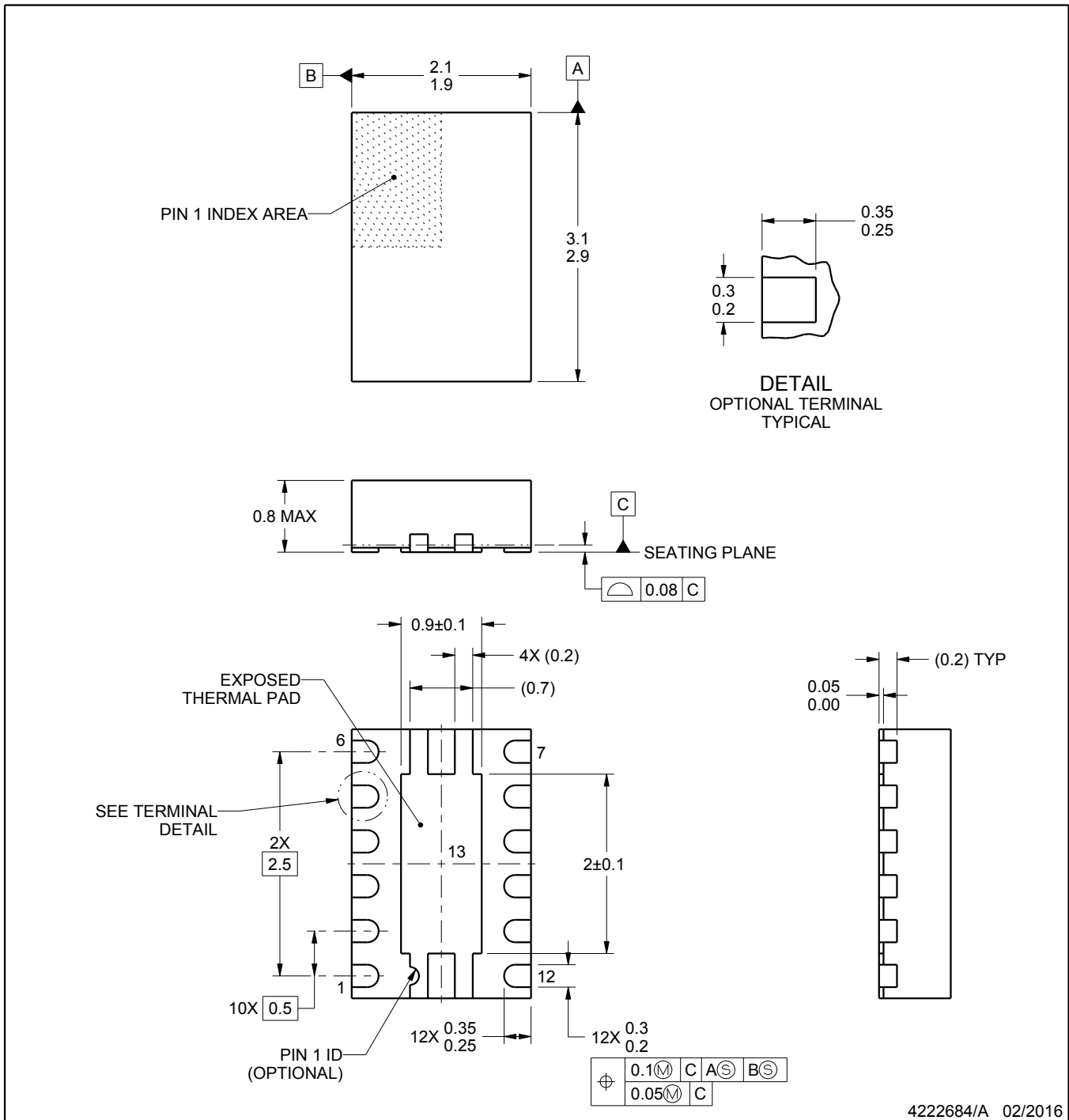

NOTES:

1. All linear dimensions are in millimeters. Any dimensions in parenthesis are for reference only. Dimensioning and tolerancing per ASME Y14.5M.
2. This drawing is subject to change without notice.
3. The package thermal pad must be soldered to the printed circuit board for thermal and mechanical performance.

EXAMPLE STENCIL DESIGN

DSS0012A

WSON - 0.8 mm max height

PLASTIC SMALL OUTLINE - NO LEAD

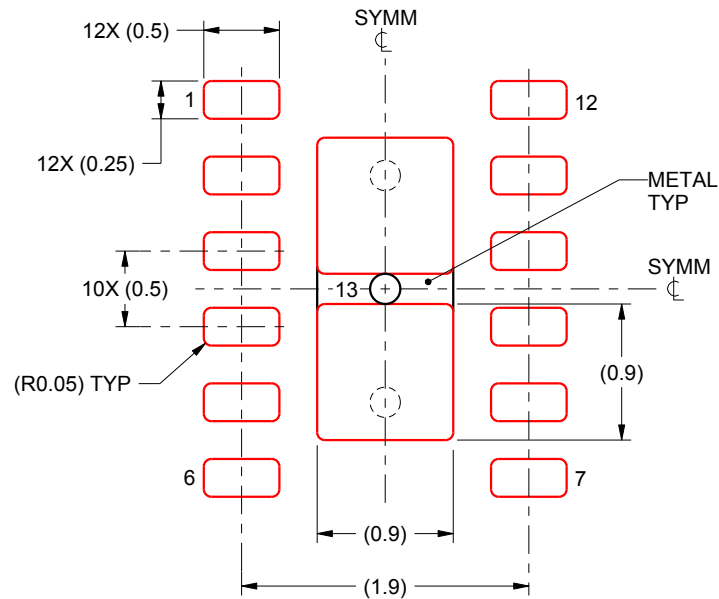

SOLDER PASTE EXAMPLE
BASED ON 0.125 mm THICK STENCIL

EXPOSED PAD 13:
90% PRINTED SOLDER COVERAGE BY AREA UNDER PACKAGE
SCALE:20X

4222684/A 02/2016

NOTES: (continued)

6. Laser cutting apertures with trapezoidal walls and rounded corners may offer better paste release. IPC-7525 may have alternate design recommendations.

IMPORTANT NOTICE

Texas Instruments Incorporated (TI) reserves the right to make corrections, enhancements, improvements and other changes to its semiconductor products and services per JESD46, latest issue, and to discontinue any product or service per JESD48, latest issue. Buyers should obtain the latest relevant information before placing orders and should verify that such information is current and complete.

TI's published terms of sale for semiconductor products (<http://www.ti.com/sc/docs/stdterms.htm>) apply to the sale of packaged integrated circuit products that TI has qualified and released to market. Additional terms may apply to the use or sale of other types of TI products and services.

Reproduction of significant portions of TI information in TI data sheets is permissible only if reproduction is without alteration and is accompanied by all associated warranties, conditions, limitations, and notices. TI is not responsible or liable for such reproduced documentation. Information of third parties may be subject to additional restrictions. Resale of TI products or services with statements different from or beyond the parameters stated by TI for that product or service voids all express and any implied warranties for the associated TI product or service and is an unfair and deceptive business practice. TI is not responsible or liable for any such statements.

Buyers and others who are developing systems that incorporate TI products (collectively, "Designers") understand and agree that Designers remain responsible for using their independent analysis, evaluation and judgment in designing their applications and that Designers have full and exclusive responsibility to assure the safety of Designers' applications and compliance of their applications (and of all TI products used in or for Designers' applications) with all applicable regulations, laws and other applicable requirements. Designer represents that, with respect to their applications, Designer has all the necessary expertise to create and implement safeguards that (1) anticipate dangerous consequences of failures, (2) monitor failures and their consequences, and (3) lessen the likelihood of failures that might cause harm and take appropriate actions. Designer agrees that prior to using or distributing any applications that include TI products, Designer will thoroughly test such applications and the functionality of such TI products as used in such applications.

TI's provision of technical, application or other design advice, quality characterization, reliability data or other services or information, including, but not limited to, reference designs and materials relating to evaluation modules, (collectively, "TI Resources") are intended to assist designers who are developing applications that incorporate TI products; by downloading, accessing or using TI Resources in any way, Designer (individually or, if Designer is acting on behalf of a company, Designer's company) agrees to use any particular TI Resource solely for this purpose and subject to the terms of this Notice.

TI's provision of TI Resources does not expand or otherwise alter TI's applicable published warranties or warranty disclaimers for TI products, and no additional obligations or liabilities arise from TI providing such TI Resources. TI reserves the right to make corrections, enhancements, improvements and other changes to its TI Resources. TI has not conducted any testing other than that specifically described in the published documentation for a particular TI Resource.

Designer is authorized to use, copy and modify any individual TI Resource only in connection with the development of applications that include the TI product(s) identified in such TI Resource. NO OTHER LICENSE, EXPRESS OR IMPLIED, BY ESTOPPEL OR OTHERWISE TO ANY OTHER TI INTELLECTUAL PROPERTY RIGHT, AND NO LICENSE TO ANY TECHNOLOGY OR INTELLECTUAL PROPERTY RIGHT OF TI OR ANY THIRD PARTY IS GRANTED HEREIN, including but not limited to any patent right, copyright, mask work right, or other intellectual property right relating to any combination, machine, or process in which TI products or services are used. Information regarding or referencing third-party products or services does not constitute a license to use such products or services, or a warranty or endorsement thereof. Use of TI Resources may require a license from a third party under the patents or other intellectual property of the third party, or a license from TI under the patents or other intellectual property of TI.

TI RESOURCES ARE PROVIDED "AS IS" AND WITH ALL FAULTS. TI DISCLAIMS ALL OTHER WARRANTIES OR REPRESENTATIONS, EXPRESS OR IMPLIED, REGARDING RESOURCES OR USE THEREOF, INCLUDING BUT NOT LIMITED TO ACCURACY OR COMPLETENESS, TITLE, ANY EPIDEMIC FAILURE WARRANTY AND ANY IMPLIED WARRANTIES OF MERCHANTABILITY, FITNESS FOR A PARTICULAR PURPOSE, AND NON-INFRINGEMENT OF ANY THIRD PARTY INTELLECTUAL PROPERTY RIGHTS. TI SHALL NOT BE LIABLE FOR AND SHALL NOT DEFEND OR INDEMNIFY DESIGNER AGAINST ANY CLAIM, INCLUDING BUT NOT LIMITED TO ANY INFRINGEMENT CLAIM THAT RELATES TO OR IS BASED ON ANY COMBINATION OF PRODUCTS EVEN IF DESCRIBED IN TI RESOURCES OR OTHERWISE. IN NO EVENT SHALL TI BE LIABLE FOR ANY ACTUAL, DIRECT, SPECIAL, COLLATERAL, INDIRECT, PUNITIVE, INCIDENTAL, CONSEQUENTIAL OR EXEMPLARY DAMAGES IN CONNECTION WITH OR ARISING OUT OF TI RESOURCES OR USE THEREOF, AND REGARDLESS OF WHETHER TI HAS BEEN ADVISED OF THE POSSIBILITY OF SUCH DAMAGES.

Unless TI has explicitly designated an individual product as meeting the requirements of a particular industry standard (e.g., ISO/TS 16949 and ISO 26262), TI is not responsible for any failure to meet such industry standard requirements.

Where TI specifically promotes products as facilitating functional safety or as compliant with industry functional safety standards, such products are intended to help enable customers to design and create their own applications that meet applicable functional safety standards and requirements. Using products in an application does not by itself establish any safety features in the application. Designers must ensure compliance with safety-related requirements and standards applicable to their applications. Designer may not use any TI products in life-critical medical equipment unless authorized officers of the parties have executed a special contract specifically governing such use. Life-critical medical equipment is medical equipment where failure of such equipment would cause serious bodily injury or death (e.g., life support, pacemakers, defibrillators, heart pumps, neurostimulators, and implantables). Such equipment includes, without limitation, all medical devices identified by the U.S. Food and Drug Administration as Class III devices and equivalent classifications outside the U.S.

TI may expressly designate certain products as completing a particular qualification (e.g., Q100, Military Grade, or Enhanced Product). Designers agree that it has the necessary expertise to select the product with the appropriate qualification designation for their applications and that proper product selection is at Designers' own risk. Designers are solely responsible for compliance with all legal and regulatory requirements in connection with such selection.

Designer will fully indemnify TI and its representatives against any damages, costs, losses, and/or liabilities arising out of Designer's non-compliance with the terms and provisions of this Notice.