



1M × 4 BANKS × 32 BITS GDDR SDRAM

Table of Contents-

1. GENERAL DESCRIPTION	4
2. FEATURES	4
3. KEY PARAMETERS	5
4. BALL CONFIGURATION	6
5. BALL DESCRIPTION	7
6. BLOCK DIAGRAM	9
7. FUNCTIONAL DESCRIPTION	10
7.1 Power Up Sequence	10
7.2 Command Function	11
7.2.1 Bank Activate Command	11
7.2.2 Bank Precharge Command	11
7.2.3 Precharge All Command	11
7.2.4 Write Command	11
7.2.5 Write with Auto-precharge Command	11
7.2.6 Read Command	11
7.2.7 Read with Auto-precharge Command	11
7.2.8 Mode Register Set Command	12
7.2.9 Extended Mode Register Set Command	12
7.2.10 No-Operation Command	12
7.2.11 Burst Read Stop Command	12
7.2.12 Device Deselect Command	12
7.2.13 Auto Refresh Command	12
7.2.14 Self Refresh Entry Command	13
7.2.15 Self Refresh Exit Command	13
7.2.16 Data Write Enable /Disable Command	13
7.3 Read Operation	13
7.4 Write Operation	14
7.5 Precharge	14
7.6 Burst Termination	14
7.7 Refresh Operation	14
7.8 Power Down Mode	15
7.9 Input Clock Frequency Change during Precharge Power Down Mode	15
7.10 Mode Register Operation	15
7.10.1 Burst Length field (A2 to A0)	16
7.10.2 Addressing Mode Select (A3)	16



7.10.3	CAS Latency field (A6 to A4).....	17
7.10.4	DLL Reset bit (A8).....	17
7.10.5	Mode Register /Extended Mode register change bits (BA0, BA1).....	17
7.10.6	Extended Mode Register field	18
7.10.7	Reserved field	18
8.	OPERATION MODE.....	19
8.1	Simplified Truth Table.....	19
8.2	Function Truth Table	20
8.3	Function Truth Table, continued	21
8.4	Function Truth Table, continued	22
8.5	Function Truth Table for CKE	23
8.6	Simplified Stated Diagram	24
9.	ELECTRICAL CHARACTERISTICS.....	25
9.1	Absolute Maximum Ratings	25
9.2	Recommended DC Operating Conditions	25
9.3	Capacitance	26
9.4	Leakage and Output Buffer Characteristics.....	26
9.5	DC Characteristics.....	27
9.6	AC Characteristics and Operating Condition	28
9.7	AC Test Conditions.....	29
10.	TIMING WAVEFORMS	32
10.1	Command Input Timing	32
10.2	Timing of the CLK Signals	32
10.3	Read Timing (Burst Length = 4)	33
10.4	Write Timing (Burst Length = 4).....	34
10.5	DM, DATA MASK (W9412G2IB)	35
10.6	Mode Register Set (MRS) Timing.....	36
10.7	Extend Mode Register Set (EMRS) Timing	37
10.8	Auto-precharge Timing (Read Cycle, CL = 2).....	38
10.9	Auto-precharge Timing (Read cycle, CL = 2), continued	39
10.10	Auto-precharge Timing (Write Cycle)	40
10.11	Read Interrupted by Read (CL = 2, BL = 2, 4, 8).....	41
10.12	Burst Read Stop (BL = 8)	41
10.13	Read Interrupted by Write & BST (BL = 8)	42
10.14	Read Interrupted by Precharge (BL = 8)	42
10.15	Write Interrupted by Write (BL = 2, 4, 8).....	43
10.16	Write Interrupted by Read (CL = 2, BL = 8).....	43
10.17	Write Interrupted by Read (CL = 3, BL = 4).....	44
10.18	Write Interrupted by Precharge (BL = 8).....	44



10.19 2 Bank Interleave Read Operation (CL = 2, BL = 2).....45

10.20 2 Bank Interleave Read Operation (CL = 2, BL = 4).....45

10.21 4 Bank Interleave Read Operation (CL = 2, BL = 2).....46

10.22 4 Bank Interleave Read Operation (CL = 2, BL = 4).....46

10.23 Auto Refresh Cycle.....47

10.24 Precharge/Activate Power Down Mode Entry and Exit Timing47

10.25 Input Clock Frequency Change during Precharge Power Down Mode Timing47

10.26 Self Refresh Entry and Exit Timing.....48

11. PACKAGE SPECIFICATION49

 11.1 144L LFBGA (12X12X1.40 mm³, Ø=0.5mm)49

12. REVISION HISTORY50



1. GENERAL DESCRIPTION

W9412G2IB is a CMOS Double Data Rate synchronous dynamic random access memory (DDR SDRAM); organized as 1,048,576 words \times 4 banks \times 32 bits. W9412G2IB delivers a data bandwidth of up to 500M words per second (-4). To fully comply with the personal computer industrial standard, W9412G2IB is sorted into following speed grades: -4, -5, -5I, -6 and -6I. The -4 is compliant to the DDR500/CL3 or CL4 specification. The -5/-5I is compliant to the DDR400/CL3 specification (-5I grade which is guaranteed to support $-40^{\circ}\text{C} \sim 85^{\circ}\text{C}$). The -6/-6I is compliant to the DDR333/CL2.5 specification (-6I grade which is guaranteed to support $-40^{\circ}\text{C} \sim 85^{\circ}\text{C}$).

All Input reference to the positive edge of CLK (except for DQ, DM and CKE). The timing reference point for the differential clock is when the CLK and $\overline{\text{CLK}}$ signals cross during a transition. Write and Read data are synchronized with the both edges of DQS (Data Strobe).

By having a programmable Mode Register, the system can change burst length, latency cycle, interleave or sequential burst to maximize its performance. W9412G2IB is ideal for any high performance applications.

2. FEATURES

- 2.5V \pm 0.2V Power Supply for DDR 333/400
- 2.5V \pm 0.1V Power Supply for DDR500
- Up to 250 MHz Clock Frequency
- Double Data Rate architecture; two data transfers per clock cycle
- Differential clock inputs (CLK and $\overline{\text{CLK}}$)
- DQS is edge-aligned with data for Read; center-aligned with data for Write
- CAS Latency: 2, 2.5, 3 and 4
- Burst Length: 2, 4 and 8
- Auto Refresh and Self Refresh
- Precharged Power Down and Active Power Down
- Write Data Mask
- Write Latency = 1
- 15.6 μ S Refresh interval (4K/64 mS Refresh)
- Maximum burst refresh cycle: 8
- Interface: SSTL_2
- Packaged in 144L LFBGA, using Lead free materials with RoHS compliant



3. KEY PARAMETERS

SYMBOL	DESCRIPTION	MIN./MAX.	-4	-5/-5I	-6/-6I	
tCK	Clock Cycle Time	CL = 2	Min.	-	7.5 nS	7.5 nS
			Max.	-	12 nS	12 nS
		CL = 2.5	Min.	-	6 nS	6 nS
			Max.	-	12 nS	12 nS
		CL = 3	Min.	4 nS	5 nS	6 nS
			Max.	12 nS	12 nS	12 nS
CL = 4	Min.	4 nS	-	-		
	Max.	12 nS	-	-		
tRAS	Active to Precharge Command Period	Min.	40 nS	40 nS	42 nS	
tRC	Active to Ref/Active Command Period	Min.	48 nS	50 nS	54 nS	
IDD0	Operating Current: One Bank Active-Precharge	Max.	160 mA	150 mA	140 mA	
IDD1	Operating Current: One Bank Active-Read-Precharge	Max.	180 mA	170 mA	160 mA	
IDD4R	Burst Operation Read Current	Max.	240 mA	220 mA	200 mA	
IDD4W	Burst Operation Write Current	Max.	270 mA	250 mA	230 mA	
IDD5	Auto Refresh Current	Max.	210 mA	200 mA	190 mA	
IDD6	Self-Refresh Current	Max.	3 mA	3 mA	3 mA	



4. BALL CONFIGURATION

	1	2	3	4	5	6	7	8	9	10	11	12
A	DQS0	DM0	VSSQ	DQ3	DQ2	DQ0	DQ31	DQ29	DQ28	VSSQ	DM3	DQS3
B	DQ4	VDDQ	NC	VDDQ	DQ1	VDDQ	VDDQ	DQ30	VDDQ	NC	VDDQ	DQ27
C	DQ6	DQ5	VSSQ	VSSQ	VSSQ	VDD	VDD	VSSQ	VSSQ	VSSQ	DQ26	DQ25
D	DQ7	VDDQ	VDD	VSS	VSSQ	VSS	VSS	VSSQ	VSS	VDD	VDDQ	DQ24
E	DQ17	DQ16	VDDQ	VSSQ	VSS	VSS	VSS	VSS	VSSQ	VDDQ	DQ15	DQ14
F	DQ19	DQ18	VDDQ	VSSQ	VSS	VSS	VSS	VSS	VSSQ	VDDQ	DQ13	DQ12
G	DQS2	DM2	NC	VSSQ	VSS	VSS	VSS	VSS	VSSQ	NC	DM1	DQS1
H	DQ21	DQ20	VDDQ	VSSQ	VSS	VSS	VSS	VSS	VSSQ	VDDQ	DQ11	DQ10
J	DQ22	DQ23	VDDQ	VSSQ	VSS	VSS	VSS	VSS	VSSQ	VDDQ	DQ9	DQ8
K	/CAS	/WE	VDD	VSS	A10	VDD	VDD	RFU (A12)	VSS	VDD	NC	NC
L	/RAS	NC	NC	BA1	A2	A11	A9	A5	RFU (BA2)	CK	/CK	NC
M	/CS	NC	BA0	A0	A1	A3	A4	A6	A7	A8/AP	CKE	VREF



5. BALL DESCRIPTION

BALL LOCATION	PIN NAME	FUNCTION	DESCRIPTION
M4-M10, L5-L8, K5	A0-A11	Address	Multiplexed pins for row and column address. Row address: A0-A11. Column address: A0-A7. (A8 is used for Auto-precharge)
M3, L4	BA0, BA1	Bank Address	Select bank to activate during row address latch time, or bank to read/write during column address latch time.
A4-A9,B1,B5,B8, B12,C1,C2,C11,C1 2,D1,D12,E1,E2,E1 1,E12,F1,F2,F11,F1 2,H1,H2,H11,H12,J 1,J2,J11,J12	DQ0-DQ31	Data Input/ Output	The DQ0-DQ31 input and output data are synchronized with both edges of DQS.
A1,A12,G1,G12	DQS0-DQS3	Data Strobe	DQS is Bi-directional signal. DQS is input signal during write operation and output signal during read operation. It is Edge-aligned with read data, Center-aligned with write data.
M1	\overline{CS}	Chip Select	Disable or enable the command decoder. When command decoder is disabled, new command is ignored and previous operation continues.
K1,K2,L1	\overline{RAS} , \overline{CAS} , \overline{WE}	Command Inputs	Command inputs (along with \overline{CS}) define the command being entered.
A2,A11,G2,G11	DM0-DM3	Write mask	DM is an input mask signal for writes data. When DM is asserted "high" in burst write, the input data is masked. DM is synchronized with both edges of DQS.
L10,L11	\overline{CLK} , CLK	Differential clock inputs	All address and control input signals are sampled on the crossing of the positive edge of CLK and negative edge of \overline{CLK} .
M11	CKE	Clock Enable	CKE controls the clock activation and deactivation. CKE is synchronous for POWER-DOWN entry and exit, and for SELF REFRESH entry CKE must be maintained high throughout READ and WRITE accesses. Input buffers, excluding CLK, \overline{CLK} and CKE are disabled during POWER-DOWN. Input buffers, excluding CKE are disabled during SELF REFRESH.
M12	VREF	Reference Voltage	VREF is reference voltage for inputs.
C6,C7,D3,D10,K3,K 6, K7,K10	VDD	Power (+2.5V)	Power for logic circuit inside DDR SDRAM.



BALL DESCRIPTION, continued

BALL LOCATION	PIN NAME	FUNCTION	DESCRIPTION
D4,D6,D7,D9, E5~E8,F5~F8,G5~ G8,H5~H8,J5~J8,K 4,K9	V _{SS}	Ground	Ground for logic circuit inside DDR SDRAM.
B2,B4,B6,B7, B9,B11,D2,D11,E3, E10,F3,F10,H3,H10 ,J3,J10	V _{DDQ}	Power (+ 2.5V) for I/O buffer	Separated power from V _{DD} , used for output buffer, to improve noise immunity.
A3,A10,C3~C5, C8~C10,D5,D8,E4, E9,F4,F9,G4,G9,H4 ,H9,J4,J9	V _{SSQ}	Ground for I/O buffer	Separated ground from V _{SS} , used for output buffer, to improve noise immunity.
B3,B10,G3,G10,K1 1,K12,L2,L3,L12,M 2	NC	No Connection	No connection
K8,L9	RFU	No Connection	Reserved for Future Use.



6. BLOCK DIAGRAM

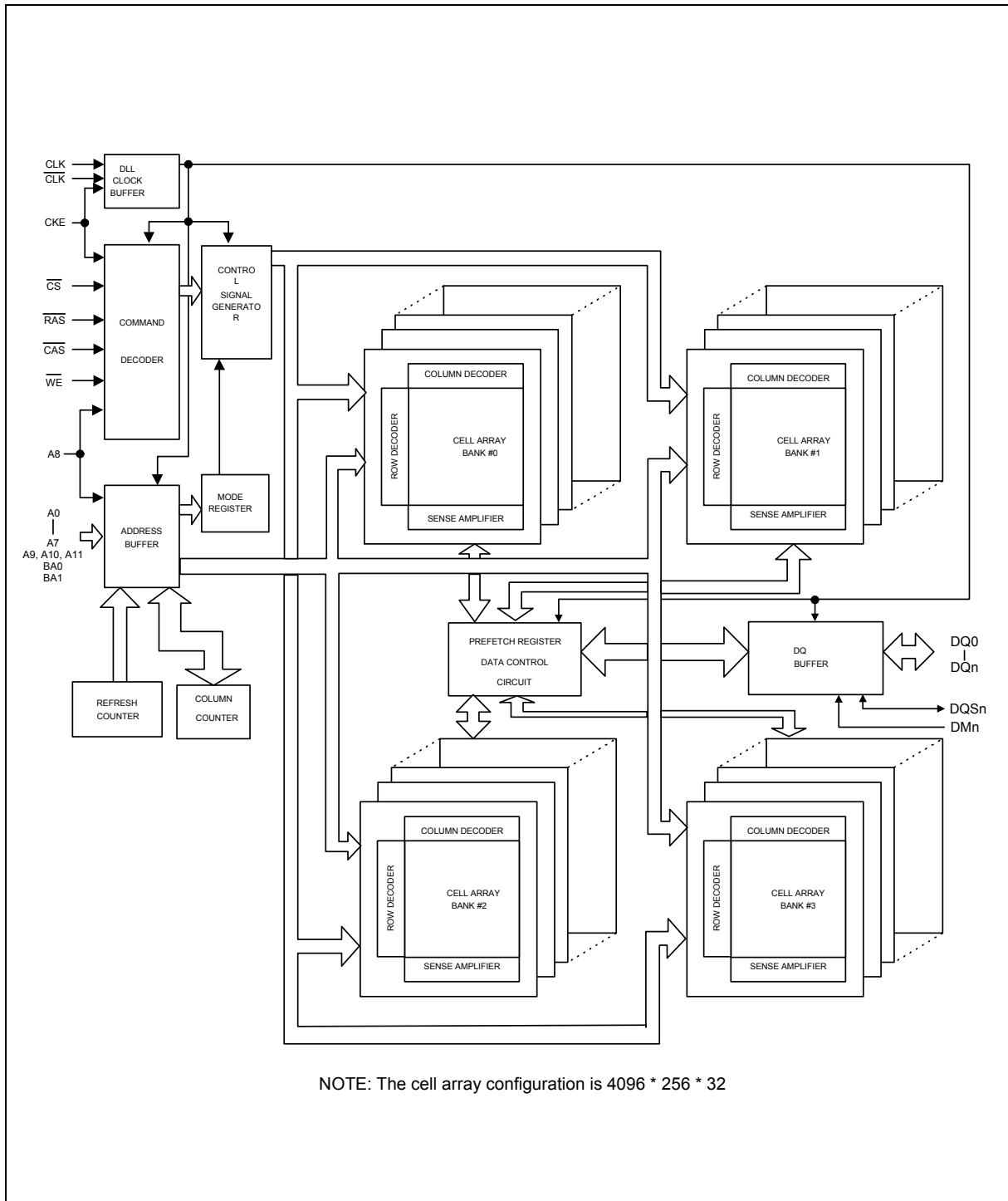



7. FUNCTIONAL DESCRIPTION

7.1 Power Up Sequence

- (1) Apply power and attempt to CKE at a low state ($\leq 0.2V$), all other inputs may be undefined
 - 1) Apply VDD before or at the same time as VDDQ.
 - 2) Apply VDDQ before or at the same time as VTT and VREF.
- (2) Start Clock and maintain stable condition for 200 μS (min.).
- (3) After stable power and clock, apply NOP and take CKE high.
- (4) Issue precharge command for all banks of the device.
- (5) Issue EMRS (Extended Mode Register Set) to enable DLL and establish Output Driver Type.
- (6) Issue MRS (Mode Register Set) to reset DLL and set device to idle with bit A8.
- (An additional 200 cycles(min) of clock are required for DLL Lock before any executable command applied.)
- (7) Issue precharge command for all banks of the device.
- (8) Issue two or more Auto Refresh commands.
- (9) Issue MRS-Initialize device operation with the reset DLL bit deactivated A8 to low.

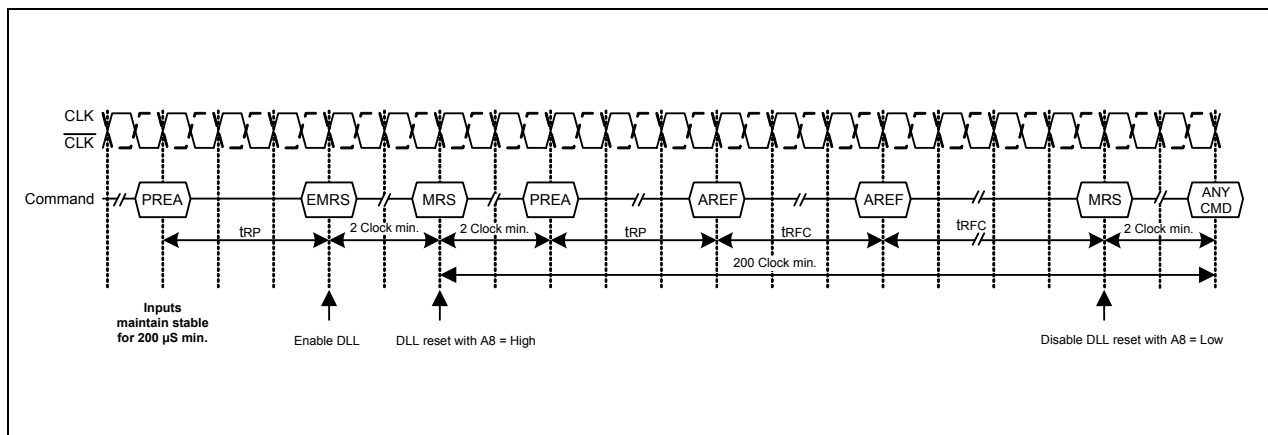

Initialization sequence after power-up



7.2 Command Function

7.2.1 Bank Activate Command

($\overline{\text{RAS}}$ = "L", $\overline{\text{CAS}}$ = "H", $\overline{\text{WE}}$ = "H", BA0, BA1 = Bank, A0 to A11 = Row Address)

The Bank Activate command activates the bank designated by the BA (Bank address) signal. Row addresses are latched on A0 to A11 when this command is issued and the cell data is read out of the sense amplifiers. The maximum time that each bank can be held in the active state is specified as $t_{\text{RAS}}(\text{max})$. After this command is issued, Read or Write operation can be executed.

7.2.2 Bank Precharge Command

($\overline{\text{RAS}}$ = "L", $\overline{\text{CAS}}$ = "H", $\overline{\text{WE}}$ = "L", BA0, BA1 = Bank, A8 = "L", A0 to A7, A9 to A11 = Don't Care)

The Bank Precharge command precharges the bank designated by BA. The precharged bank is switched from the active state to the idle state.

7.2.3 Precharge All Command

($\overline{\text{RAS}}$ = "L", $\overline{\text{CAS}}$ = "H", $\overline{\text{WE}}$ = "L", BA0, BA1 = Don't Care, A8 = "H", A0 to A7, A9 to A11 = Don't Care)

The Precharge All command precharges all banks simultaneously. Then all banks are switched to the idle state.

7.2.4 Write Command

($\overline{\text{RAS}}$ = "H", $\overline{\text{CAS}}$ = "L", $\overline{\text{WE}}$ = "L", BA0, BA1 = Bank, A8 = "L", A0 to A7 = Column Address)

The write command performs a Write operation to the bank designated by BA. The write data are latched at both edges of DQS. The length of the write data (Burst Length) and column access sequence (Addressing Mode) must be in the Mode Register at power-up prior to the Write operation.

7.2.5 Write with Auto-precharge Command

($\overline{\text{RAS}}$ = "H", $\overline{\text{CAS}}$ = "L", $\overline{\text{WE}}$ = "L", BA0, BA1 = Bank, A8 = "H", A0 to A7 = Column Address)

The Write with Auto-precharge command performs the Precharge operation automatically after the Write operation. This command must not be interrupted by any other commands.

7.2.6 Read Command

($\overline{\text{RAS}}$ = "H", $\overline{\text{CAS}}$ = "L", $\overline{\text{WE}}$ = "H", BA0, BA1 = Bank, A8 = "L", A0 to A7 = Column Address)

The Read command performs a Read operation to the bank designated by BA. The read data are synchronized with both edges of DQS. The length of read data (Burst Length), Addressing Mode and CAS Latency (access time from $\overline{\text{CAS}}$ command in a clock cycle) must be programmed in the Mode Register at power-up prior to the Read operation.

7.2.7 Read with Auto-precharge Command

($\overline{\text{RAS}}$ = "H", $\overline{\text{CAS}}$ = "L", $\overline{\text{WE}}$ = "H", BA0, BA1 = Bank, A8 = "H", A0 to A7 = Column Address)

The Read with Auto-precharge command automatically performs the Precharge operation after the Read operation.



1) $READA \geq t_{RAS}(\min) - (BL/2) \times t_{CK}$

Internal precharge operation begins after BL/2 cycle from Read with Auto-precharge command.

2) $t_{RCD}(\min) \leq READA < t_{RAS}(\min) - (BL/2) \times t_{CK}$

Data can be read with shortest latency, but the internal Precharge operation does not begin until after $t_{RAS}(\min)$ has completed.

This command must not be interrupted by any other command.

7.2.8 Mode Register Set Command

($\overline{RAS} = "L"$, $\overline{CAS} = "L"$, $\overline{WE} = "L"$, BA0 = "L", BA1 = "L", A0 to A11 = Register Data)

The Mode Register Set command programs the values of CAS Latency, Addressing Mode, Burst Length and DLL reset in the Mode Register. The default values in the Mode Register after power-up are undefined, therefore this command must be issued during the power-up sequence. Also, this command can be issued while all banks are in the idle state. Refer to the table for specific codes.

7.2.9 Extended Mode Register Set Command

($\overline{RAS} = "L"$, $\overline{CAS} = "L"$, $\overline{WE} = "L"$, BA0 = "H", BA1 = "L", A0 to A11 = Register data)

The Extended Mode Register Set command can be implemented as needed for function extensions to the standard (SDR-SDRAM). Currently the only available mode in EMRS is DLL enable/disable, decoded by A0. The default value of the extended mode register is not defined; therefore this command must be issued during the power-up sequence for enabling DLL. Refer to the table for specific codes.

7.2.10 No-Operation Command

($\overline{RAS} = "H"$, $\overline{CAS} = "H"$, $\overline{WE} = "H"$)

The No-Operation command simply performs no operation (same command as Device Deselect).

7.2.11 Burst Read Stop Command

($\overline{RAS} = "H"$, $\overline{CAS} = "H"$, $\overline{WE} = "L"$)

The Burst stop command is used to stop the burst operation. This command is only valid during a Burst Read operation.

7.2.12 Device Deselect Command

($\overline{CS} = "H"$)

The Device Deselect command disables the command decoder so that the \overline{RAS} , \overline{CAS} , \overline{WE} and Address inputs are ignored. This command is similar to the No-Operation command.

7.2.13 Auto Refresh Command

($\overline{RAS} = "L"$, $\overline{CAS} = "L"$, $\overline{WE} = "H"$, CKE = "H", BA0, BA1, A0 to A11 = Don't Care)

AUTO REFRESH is used during normal operation of the DDR SDRAM and is analogous to CAS-BEFORE-RAS (CBR) refresh in previous DRAM types. This command is non-persistent, so it must be issued each time a refresh is required.



The refresh addressing is generated by the internal refresh controller. This makes the address bits "Don't Care" during an AUTO REFRESH command. The DDR SDRAM requires AUTO REFRESH cycles at an average periodic interval of t_{REFI} (maximum).

To allow for improved efficiency in scheduling and switching between tasks, some flexibility in the absolute refresh interval is provided. A maximum of eight AUTO REFRESH commands can be posted to any given DDR SDRAM, and the maximum absolute interval between any AUTO REFRESH command and the next AUTO REFRESH command is $8 * t_{REFI}$.

7.2.14 Self Refresh Entry Command

(\overline{RAS} = "L", \overline{CAS} = "L", \overline{WE} = "H", CKE = "L", BA0, BA1, A0 to A11 = Don't Care)

The SELF REFRESH command can be used to retain data in the DDR SDRAM, even if the rest of the system is powered down. When in the self refresh mode, the DDR SDRAM retains data without external clocking. The SELF REFRESH command is initiated like an AUTO REFRESH command except CKE is disabled (LOW). The DLL is automatically disabled upon entering SELF REFRESH, and is automatically enabled upon exiting SELF REFRESH. Any time the DLL is enabled a DLL Reset must follow and 200 clock cycles should occur before a READ command can be issued. Input signals except CKE are "Don't Care" during SELF REFRESH. Since CKE is an SSTL_2 input, V_{REF} must be maintained during SELF REFRESH.

7.2.15 Self Refresh Exit Command

(CKE = "H", \overline{CS} = "H" or CKE = "H", \overline{RAS} = "H", \overline{CAS} = "H")

The procedure for exiting self refresh requires a sequence of commands. First, CLK must be stable prior to CKE going back HIGH. Once CKE is HIGH, the DDR SDRAM must have NOP commands issued for t_{XSNR} because time is required for the completion of any internal refresh in progress. A simple algorithm for meeting both refresh and DLL requirements is to apply NOPs for 200 clock cycles before applying any other command.

The use of SELF REFRESH mode introduces the possibility that an internally timed event can be missed when CKE is raised for exit from self refresh mode. Upon exit from SELF REFRESH an extra auto refresh command is recommended.

7.2.16 Data Write Enable /Disable Command

(DM = "L/H" or DM0–DM3 = "L/H")

During a Write cycle, the DM0–DM3, DMs signal functions as Data Mask and can control every word of the input data. The DM0 signal controls DQ0 to DQ7, DM1 signal controls DQ8 to DQ15, DM2 signal controls DQ16 to DQ23 and DM3 signal controls DQ24 to DQ31.

7.3 Read Operation

Issuing the Bank Activate command to the idle bank puts it into the active state. When the Read command is issued after t_{RCD} from the Bank Activate command, the data is read out sequentially, synchronized with both edges of DQS (Burst Read operation). The initial read data becomes available after CAS Latency from the issuing of the Read command. The CAS Latency must be set in the Mode Register at power-up.

When the Precharge Operation is performed on a bank during a Burst Read and operation, the Burst operation is terminated.

When the Read with Auto-precharge command is issued, the Precharge operation is performed automatically after the Read cycle, then the bank is switched to the idle state. This command cannot be interrupted by any other commands. Refer to the diagrams for Read operation.



7.4 Write Operation

Issuing the Write command after t_{RC} from the bank activate command. The input data is latched sequentially, synchronizing with both edges (rising & falling) of DQS after the Write command (Burst write operation). The burst length of the Write data (Burst Length) and Addressing Mode must be set in the Mode Register at power-up.

When the Precharge operation is performed in a bank during a Burst Write operation, the Burst operation is terminated.

When the Write with Auto-precharge command is issued, the Precharge operation is performed automatically after the Write cycle, then the bank is switched to the idle state. The Write with Auto-precharge command cannot be interrupted by any other command for the entire burst data duration.

Refer to the diagrams for Write operation.

7.5 Precharge

There are two Commands, which perform the precharge operation (Bank Precharge and Precharge All). When the Bank Precharge command is issued to the active bank, the bank is precharged and then switched to the idle state. The Bank Precharge command can precharge one bank independently of the other bank and hold the unprecharged bank in the active state. The maximum time each bank can be held in the active state is specified as $t_{RAS(max)}$. Therefore, each bank must be precharged within $t_{RAS(max)}$ from the bank activate command.

The Precharge All command can be used to precharge all banks simultaneously. Even if banks are not in the active state, the Precharge All command can still be issued. In this case, the Precharge operation is performed only for the active bank and the precharge bank is then switched to the idle state.

7.6 Burst Termination

When the Precharge command is used for a bank in a Burst cycle, the Burst operation is terminated. When Burst Read cycle is interrupted by the Precharge command, read operation is disabled after clock cycle of (CAS Latency) from the Precharge command. When the Burst Write cycle is interrupted by the Precharge command, the input circuit is reset at the same clock cycle at which the precharge command is issued. In this case, the DM signal must be asserted "high" during t_{WR} to prevent writing the invalidated data to the cell array.

When the Burst Read Stop command is issued for the bank in a Burst Read cycle, the Burst Read operation is terminated. The Burst read Stop command is not supported during a write burst operation. Refer to the diagrams for Burst termination.

7.7 Refresh Operation

Two types of Refresh operation can be performed on the device: Auto Refresh and Self Refresh. By repeating the Auto Refresh cycle, each bank in turn refreshed automatically. The Refresh operation must be performed 4096 times (rows) within 64mS. The period between the Auto Refresh command and the next command is specified by t_{RFC} .

Self Refresh mode enter issuing the Self Refresh command (CKE asserted "low"), while all banks are in the idle state. The device is in Self Refresh mode for as long as CKE held "low". In the case of distributed Auto Refresh commands, distributed auto refresh commands must be issued every 15.6 μ S and the last distributed Auto Refresh commands must be performed within 15.6 μ S before entering the self refresh mode. After exiting from the Self Refresh mode, the refresh operation must be performed within 15.6 μ S. In Self Refresh mode, all input/output buffers are disabled,



resulting in lower power dissipation (except CKE buffer). Refer to the diagrams for Refresh operation.

7.8 Power Down Mode

Two types of Power Down Mode can be performed on the device: Active Power Down Mode and Precharge Power Down Mode.

When the device enters the Power Down Mode, all input/output buffers are disabled resulting in low power dissipation (except CKE buffer).

Power Down Mode enter asserting CKE "low" while the device is not running a burst cycle. Taking CKE "high" can exit this mode. When CKE goes high, a No operation command must be input at next CLK rising edge. Refer to the diagrams for Power Down Mode.

7.9 Input Clock Frequency Change during Precharge Power Down Mode

DDR SDRAM input clock frequency can be changed under following condition:

DDR SDRAM must be in precharged power down mode with CKE at logic LOW level. After a minimum of 2 clocks after CKE goes LOW, the clock frequency may change to any frequency between minimum and maximum operating frequency specified for the particular speed grade. During an input clock frequency change, CKE must be held LOW. Once the input clock frequency is changed, a stable clock must be provided to DRAM before precharge power down mode may be exited. The DLL must be RESET via EMRS after precharge power down exit. An additional MRS command may need to be issued to appropriately set CL etc. After the DLL relock time, the DRAM is ready to operate with new clock frequency.

7.10 Mode Register Operation

The mode register is programmed by the Mode Register Set command (MRS/EMRS) when all banks are in the idle state. The data to be set in the Mode Register is transferred using the A0 to A11 and BA0, BA1 address inputs.

The Mode Register designates the operation mode for the read or write cycle. The register is divided into five fields: (1) Burst Length field to set the length of burst data (2) Addressing Mode selected bit to designate the column access sequence in a Burst cycle (3) CAS Latency field to set the access time in clock cycle (4) DLL reset field to reset the DLL (5) Regular/Extended Mode Register field to select a type of MRS (Regular/Extended MRS). EMRS cycle can be implemented the extended function (DLL enable/Disable mode).

The initial value of the Mode Register (including EMRS) after power up is undefined; therefore the Mode Register Set command must be issued before power operation.



7.10.1 Burst Length field (A2 to A0)

This field specifies the data length for column access using the A2 to A0 pins and sets the Burst Length to be 2, 4, 8 words.

A2	A1	A0	BURST LENGTH
0	0	0	Reserved
0	0	1	2 words
0	1	0	4 words
0	1	1	8 words
1	x	x	Reserved

7.10.2 Addressing Mode Select (A3)

The Addressing Mode can be one of two modes; Interleave mode or Sequential Mode, When the A3 bit is "0", Sequential mode is selected. When the A3 bit is "1", Interleave mode is selected. Both addressing Mode support burst length 2, 4 and 8 words.

A3	ADDRESSING MODE
0	Sequential
1	Interleave

- **Addressing Sequence of Sequential Mode**

A column access is performed by incrementing the column address input to the device. The address is varied by the Burst Length as the following.

Addressing Sequence of Sequential Mode

DATA	ACCESS ADDRESS	BURST LENGTH
Data 0	n	2 words (address bits is A0) not carried from A0 to A1
Data 1	n + 1	
Data 2	n + 2	4 words (address bit A0, A1) Not carried from A1 to A2
Data 3	n + 3	
Data 4	n + 4	8 words (address bits A2, A1 and A0) Not carried from A2 to A3
Data 5	n + 5	
Data 6	n + 6	
Data 7	n + 7	



- **Addressing Sequence of Interleave Mode**

A Column access is started from the inputted column address and is performed by interleaving the address bits in the sequence shown as the following.

Address Sequence for Interleave Mode

DATA	ACCESS ADDRESS	BURST LENGTH
Data 0	A8 A7 A6 A5 A4 A3 A2 A1 A0	2 words
Data 1	A8 A7 A6 A5 A4 A3 A2 A1 $\overline{A0}$	
Data 2	A8 A7 A6 A5 A4 A3 A2 $\overline{A1}$ A0	4 words
Data 3	A8 A7 A6 A5 A4 A3 A2 $\overline{A1}$ $\overline{A0}$	
Data 4	A8 A7 A6 A5 A4 A3 $\overline{A2}$ A1 A0	8 words
Data 5	A8 A7 A6 A5 A4 A3 $\overline{A2}$ A1 $\overline{A0}$	
Data 6	A8 A7 A6 A5 A4 A3 $\overline{A2}$ $\overline{A1}$ A0	
Data 7	A8 A7 A6 A5 A4 A3 $\overline{A2}$ $\overline{A1}$ $\overline{A0}$	

7.10.3 CAS Latency field (A6 to A4)

This field specifies the number of clock cycles from the assertion of the Read command to the first data read. The minimum values of CAS Latency depend on the frequency of CLK.

A6	A5	A4	CAS LATENCY
0	0	0	Reserved
0	0	1	Reserved
0	1	0	2
0	1	1	3
1	0	0	4
1	0	1	Reserved
1	1	0	2.5
1	1	1	Reserved

7.10.4 DLL Reset bit (A8)

This bit is used to reset DLL. When the A8 bit is "1", DLL is reset.

7.10.5 Mode Register /Extended Mode register change bits (BA0, BA1)

These bits are used to select MRS/EMRS.

BA1	BA0	A11-A0
0	0	Regular MRS Cycle
0	1	Extended MRS Cycle
1	x	Reserved



7.10.6 Extended Mode Register field

1) DLL Switch field (A0)

This bit is used to select DLL enable or disable

A0	DLL
0	Enable
1	Disable

2) Output Driver Strength Control field (A6, A1)

The 100%, 60% and 30% or matched impedance driver strength are required Extended Mode Register Set (EMRS) as the following:

A6	A1	BUFFER STRENGTH
0	0	100% Strength
0	1	60% Strength
1	0	Reserved
1	1	30% Strength

7.10.7 Reserved field

- Test mode entry bit (A7)
This bit is used to enter Test mode and must be set to "0" for normal operation.
- Reserved bits (A9, A10, A11)
These bits are reserved for future operations. They must be set to "0" for normal operation.



8. OPERATION MODE

The following table shows the operation commands.

8.1 Simplified Truth Table

SYM.	COMMAND	DEVICE STATE	CKE _{n-1}	CKE _n	DM ⁽⁴⁾	BA0,BA1	A8	A0-A7 A9- A11	$\overline{\text{CS}}$	$\overline{\text{RAS}}$	$\overline{\text{CAS}}$	$\overline{\text{WE}}$
ACT	Bank Active	Idle ⁽³⁾	H	X	X	V	V	V	L	L	H	H
PRE	Bank Precharge	Any ⁽³⁾	H	X	X	V	L	X	L	L	H	L
PREA	Precharge All	Any	H	X	X	X	H	X	L	L	H	L
WRIT	Write	Active ⁽³⁾	H	X	X	V	L	V	L	H	L	L
WRITA	Write with Auto-precharge	Active ⁽³⁾	H	X	X	V	H	V	L	H	L	L
READ	Read	Active ⁽³⁾	H	X	X	V	L	V	L	H	L	H
READA	Read with Auto-precharge	Active ⁽³⁾	H	X	X	V	H	V	L	H	L	H
MRS	Mode Register Set	Idle	H	X	X	L, L	C	C	L	L	L	L
EMRS	Extended Mode Register Set	Idle	H	X	X	H, L	V	V	L	L	L	L
NOP	No Operation	Any	H	X	X	X	X	X	L	H	H	H
BST	Burst Read Stop	Active	H	X	X	X	X	X	L	H	H	L
DSL	Device Deselect	Any	H	X	X	X	X	X	H	X	X	X
AREF	Auto Refresh	Idle	H	H	X	X	X	X	L	L	L	H
SELF	Self Refresh Entry	Idle	H	L	X	X	X	X	L	L	L	H
SELEX	Self Refresh Exit	Idle (Self Refresh)	L	H	X	X	X	X	H	X	X	X
			L	H	H	X						
PD	Power Down Mode Entry	Idle/ Active ⁽⁵⁾	H	L	X	X	X	X	H	X	X	X
			L	H	H	X						
PDEX	Power Down Mode Exit	Any (Power Down)	L	H	X	X	X	X	H	X	X	X
			L	H	H	X						
WDE	Data Write Enable	Active	H	X	L	X	X	X	X	X	X	X
WDD	Data Write Disable	Active	H	X	H	X	X	X	X	X	X	X

Notes:

1. V = Valid X = Don't Care L = Low level H = High level
2. CKE_n signal is input level when commands are issued.
CKE_{n-1} signal is input level one clock cycle before the commands are issued.
3. These are state designated by the BA0, BA1 signals.
4. DM0–DM3 (W9412G2IB).
5. Power Down Mode can not entry in the burst cycle.



8.2 Function Truth Table

(Note 1)

CURRENT STATE	\overline{CS}	\overline{RAS}	\overline{CAS}	\overline{WE}	ADDRESS	COMMAND	ACTION	NOTES
Idle	H	X	X	X	X	DSL	NOP	
	L	H	H	X	X	NOP/BST	NOP	
	L	H	L	H	BA, CA, A8	READ/READA	ILLEGAL	3
	L	H	L	L	BA, CA, A8	WRIT/WRITA	ILLEGAL	3
	L	L	H	H	BA, RA	ACT	Row activating	
	L	L	H	L	BA, A8	PRE/PREA	NOP	
	L	L	L	H	X	AREF/SELF	Refresh or Self refresh	2
	L	L	L	L	Op-Code	MRS/EMRS	Mode register accessing	2
Row Active	H	X	X	X	X	DSL	NOP	
	L	H	H	X	X	NOP/BST	NOP	
	L	H	L	H	BA, CA, A8	READ/READA	Begin read: Determine AP	4
	L	H	L	L	BA, CA, A8	WRIT/WRITA	Begin write: Determine AP	4
	L	L	H	H	BA, RA	ACT	ILLEGAL	3
	L	L	H	L	BA, A8	PRE/PREA	Precharge	5
	L	L	L	H	X	AREF/SELF	ILLEGAL	
	L	L	L	L	Op-Code	MRS/EMRS	ILLEGAL	
Read	H	X	X	X	X	DSL	Continue burst to end	
	L	H	H	H	X	NOP	Continue burst to end	
	L	H	H	L	X	BST	Burst stop	
	L	H	L	H	BA, CA, A8	READ/READA	Term burst, new read: Determine AP	6
	L	H	L	L	BA, CA, A8	WRIT/WRITA	ILLEGAL	
	L	L	H	H	BA, RA	ACT	ILLEGAL	3
	L	L	H	L	BA, A8	PRE/PREA	Term burst, precharging	
	L	L	L	H	X	AREF/SELF	ILLEGAL	
Write	L	L	L	L	Op-Code	MRS/EMRS	ILLEGAL	
	H	X	X	X	X	DSL	Continue burst to end	
	L	H	H	H	X	NOP	Continue burst to end	
	L	H	H	L	X	BST	ILLEGAL	
	L	H	L	H	BA, CA, A8	READ/READA	Term burst, start read: Determine AP	6, 7
	L	H	L	L	BA, CA, A8	WRIT/WRITA	Term burst, start read: Determine AP	6
	L	L	H	H	BA, RA	ACT	ILLEGAL	3
	L	L	H	L	BA, A8	PRE/PREA	Term burst, Precharging	8
	L	L	L	H	X	AREF/SELF	ILLEGAL	
L	L	L	L	Op-Code	MRS/EMRS	ILLEGAL		



8.3 Function Truth Table, continued

CURRENT STATE	\overline{CS}	RAS	\overline{CAS}	\overline{WE}	ADDRESS	COMMAND	ACTION	NOTES
Read with Auto-precharge	H	X	X	X	X	DSL	Continue burst to end	
	L	H	H	H	X	NOP	Continue burst to end	
	L	H	H	L	X	BST	ILLEGAL	
	L	H	L	H	BA, CA, A8	READ/READA	ILLEGAL	
	L	H	L	L	BA, CA, A8	WRIT/WRITA	ILLEGAL	3
	L	L	H	H	BA, RA	ACT	ILLEGAL	3
	L	L	H	L	BA, A8	PRE/PREA	ILLEGAL	
	L	L	L	H	X	AREF/SELF	ILLEGAL	
	L	L	L	L	Op-Code	MRS/EMRS	ILLEGAL	
Write with Auto-precharge	H	X	X	X	X	DSL	Continue burst to end	
	L	H	H	H	X	NOP	Continue burst to end	
	L	H	H	L	X	BST	ILLEGAL	
	L	H	L	H	BA, CA, A8	READ/READA	ILLEGAL	
	L	H	L	L	BA, CA, A8	WRIT/WRITA	ILLEGAL	
	L	L	H	H	BA, RA	ACT	ILLEGAL	3
	L	L	H	L	BA, A8	PRE/PREA	ILLEGAL	3
	L	L	L	H	X	AREF/SELF	ILLEGAL	
	L	L	L	L	Op-Code	MRS/EMRS	ILLEGAL	
Precharging	H	X	X	X	X	DSL	NOP-> Idle after trP	
	L	H	H	H	X	NOP	NOP-> Idle after trP	
	L	H	H	L	X	BST	ILLEGAL	
	L	H	L	H	BA, CA, A8	READ/READA	ILLEGAL	3
	L	H	L	L	BA, CA, A8	WRIT/WRITA	ILLEGAL	3
	L	L	H	H	BA, RA	ACT	ILLEGAL	3
	L	L	H	L	BA, A8	PRE/PREA	Idle after trP	
	L	L	L	H	X	AREF/SELF	ILLEGAL	
	L	L	L	L	Op-Code	MRS/EMRS	ILLEGAL	
Row Activating	H	X	X	X	X	DSL	NOP-> Row active after trCD	
	L	H	H	H	X	NOP	NOP-> Row active after trCD	
	L	H	H	L	X	BST	ILLEGAL	
	L	H	L	H	BA, CA, A8	READ/READA	ILLEGAL	3
	L	H	L	L	BA, CA, A8	WRIT/WRITA	ILLEGAL	3
	L	L	H	H	BA, RA	ACT	ILLEGAL	3
	L	L	H	L	BA, A8	PRE/PREA	ILLEGAL	3
	L	L	L	H	X	AREF/SELF	ILLEGAL	
	L	L	L	L	Op-Code	MRS/EMRS	ILLEGAL	



8.4 Function Truth Table, continued

CURRENT STATE	\overline{CS}	\overline{RAS}	\overline{CAS}	\overline{WE}	ADDRESS	COMMAND	ACTION	NOTES
Write Recovering	H	X	X	X	X	DSL	NOP->Row active after tWR	
	L	H	H	H	X	NOP	NOP->Row active after tWR	
	L	H	H	L	X	BST	ILLEGAL	
	L	H	L	H	BA, CA, A8	READ/READA	ILLEGAL	3
	L	H	L	L	BA, CA, A8	WRIT/WRITA	ILLEGAL	3
	L	L	H	H	BA, RA	ACT	ILLEGAL	3
	L	L	H	L	BA, A8	PRE/PREA	ILLEGAL	3
	L	L	L	H	X	AREF/SELF	ILLEGAL	
	L	L	L	L	Op-Code	MRS/EMRS	ILLEGAL	
Write Recovering with Auto- precharge	H	X	X	X	X	DSL	NOP->Enter precharge after tWR	
	L	H	H	H	X	NOP	NOP->Enter precharge after tWR	
	L	H	H	L	X	BST	ILLEGAL	
	L	H	L	H	BA, CA, A8	READ/READA	ILLEGAL	3
	L	H	L	L	BA, CA, A8	WRIT/WRITA	ILLEGAL	3
	L	L	H	H	BA, RA	ACT	ILLEGAL	3
	L	L	H	L	BA, A8	PRE/PREA	ILLEGAL	3
	L	L	L	H	X	AREF/SELF	ILLEGAL	
	L	L	L	L	Op-Code	MRS/EMRS	ILLEGAL	
Refreshing	H	X	X	X	X	DSL	NOP->Idle after tRC	
	L	H	H	H	X	NOP	NOP->Idle after tRC	
	L	H	H	L	X	BST	ILLEGAL	
	L	H	L	H	X	READ/WRIT	ILLEGAL	
	L	L	H	X	X	ACT/PRE/PREA	ILLEGAL	
	L	L	L	X	X	AREF/SELF/MRS/EMRS	ILLEGAL	
Mode Register Accessing	H	X	X	X	X	DSL	NOP->Row after tMRD	
	L	H	H	H	X	NOP	NOP->Row after tMRD	
	L	H	H	L	X	BST	ILLEGAL	
	L	H	L	X	X	READ/WRIT	ILLEGAL	
	L	L	X	X	X	ACT/PRE/PREA/AREF/SELF/MRS/EMRS	ILLEGAL	

Notes:

- All entries assume that CKE was active (High level) during the preceding clock cycle and the current clock cycle.
- Illegal if any bank is not idle.
- Illegal to bank in specified states; Function may be legal in the bank indicated by Bank Address (BA), depending on the state of that bank.
- Illegal if tRCD is not satisfied.
- Illegal if tRAS is not satisfied.
- Must satisfy burst interrupt condition.
- Must avoid bus contention, bus turn around, and/or satisfy write recovery requirements.
- Must mask preceding data which don't satisfy tWR

Remark: H = High level, L = Low level, X = High or Low level (Don't Care), V = Valid data



8.5 Function Truth Table for CKE

CURRENT STATE	CKE		\overline{CS}	\overline{RAS}	\overline{CAS}	\overline{WE}	ADDRESS	ACTION	NOTES
	n-1	n							
Self Refresh	H	X	X	X	X	X	X	INVALID	
	L	H	H	X	X	X	X	Exit Self Refresh->Idle after t _{SNR}	
	L	H	L	H	H	X	X	Exit Self Refresh->Idle after t _{SNR}	
	L	H	L	H	L	X	X	ILLEGAL	
	L	H	L	L	X	X	X	ILLEGAL	
	L	L	X	X	X	X	X	Maintain Self Refresh	
Power Down	H	X	X	X	X	X	X	INVALID	
	L	H	X	X	X	X	X	Exit Power down->Idle after t _{is}	
	L	L	X	X	X	X	X	Maintain power down mode	
All banks Idle	H	H	X	X	X	X	X	Refer to Function Truth Table	
	H	L	H	X	X	X	X	Enter Power down	2
	H	L	L	H	H	X	X	Enter Power down	2
	H	L	L	L	L	H	X	Self Refresh	1
	H	L	L	H	L	X	X	ILLEGAL	
	H	L	L	L	X	X	X	ILLEGAL	
	L	X	X	X	X	X	X	Power down	
Row Active	H	H	X	X	X	X	X	Refer to Function Truth Table	
	H	L	H	X	X	X	X	Enter Power down	3
	H	L	L	H	H	X	X	Enter Power down	3
	H	L	L	L	L	H	X	ILLEGAL	
	H	L	L	H	L	X	X	ILLEGAL	
	H	L	L	L	X	X	X	ILLEGAL	
	L	X	X	X	X	X	X	Power down	
Any State Other Than Listed Above	H	H	X	X	X	X	X	Refer to Function Truth Table	

Notes:

1. Self refresh can enter only from the all banks idle state.
2. Power Down occurs when all banks are idle; this mode is referred to as precharge power down.
3. Power Down occurs when there is a row active in any bank; this mode is referred to as active power down.

Remark: H = High level, L = Low level, X = High or Low level (Don't Care), V = Valid data



8.6 Simplified Stated Diagram

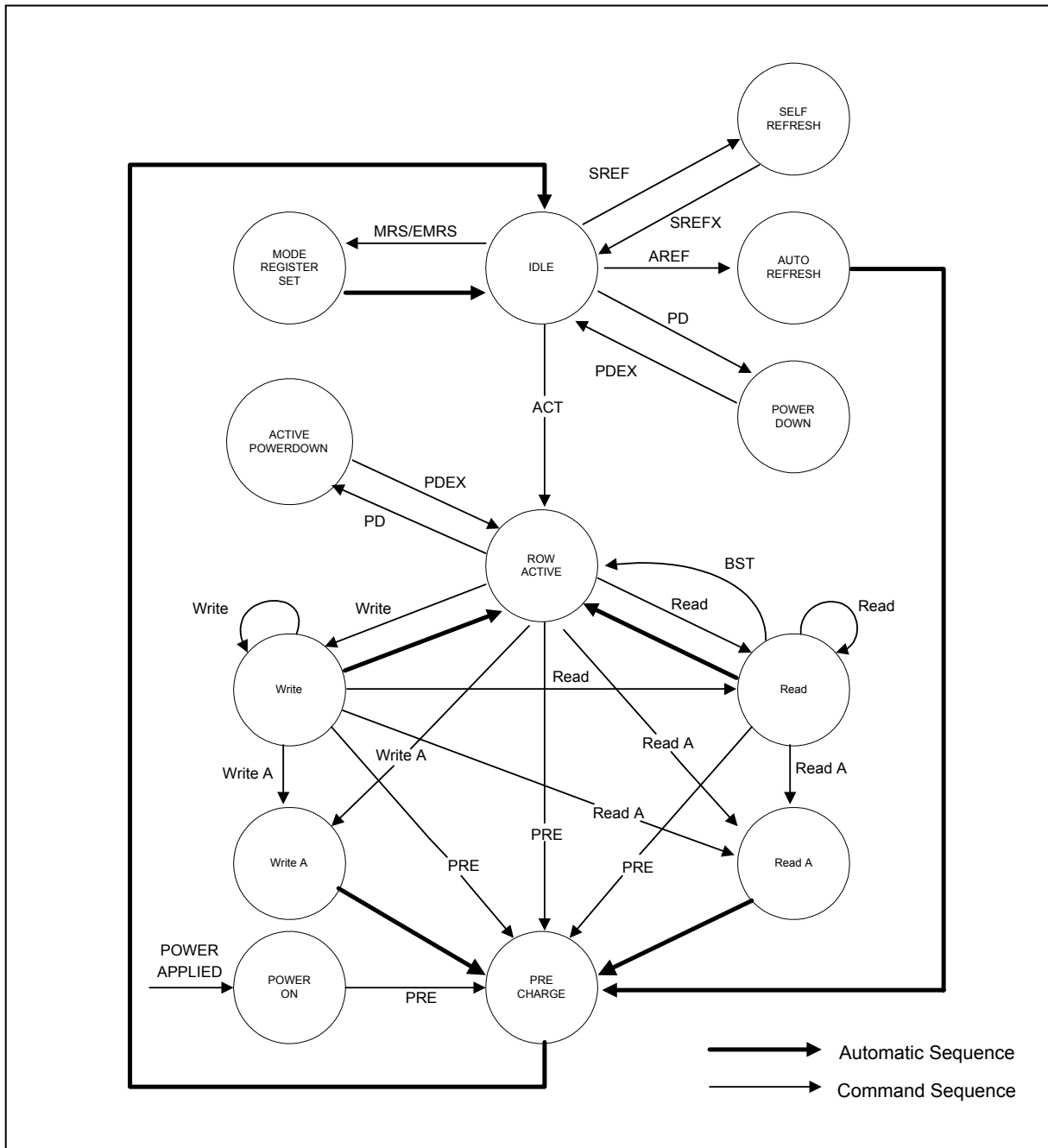



9. ELECTRICAL CHARACTERISTICS

9.1 Absolute Maximum Ratings

PARAMETER	SYMBOL	RATING	UNIT
Input/Output Voltage	V _{IN} , V _{OUT}	-0.3 ~ V _{DDQ} + 0.3	V
Power Supply Voltage	V _{DD} , V _{DDQ}	-0.3 ~ 3.6	V
Operating Temperature (-4/-5/-6)	T _{OPR}	0 ~ 70	°C
Operating Temperature (-5I/-6I)	T _{OPR}	-40 ~ 85	°C
Storage Temperature	T _{STG}	-55 ~ 150	°C
Soldering Temperature (10s)	T _{SOLDER}	260	°C
Power Dissipation	P _D	1	W
Short Circuit Output Current	I _{OUT}	50	mA

Note: Stresses greater than those listed under "Absolute Maximum Ratings" may cause permanent damage to the device.

This is a stress rating only, and functional operation of the device at these or any other conditions above those indicated in the operational sections of this specification is not implied.

Exposure to absolute maximum rating conditions for extended periods may affect reliability.

9.2 Recommended DC Operating Conditions

(T_A = 0 to 70 °C for -4/-5/-6, T_A = -40 to 85 °C for -5I/-6I)

SYM.	PARAMETER	MIN.	TYP.	MAX.	UNIT	NOTES
V _{DD}	Power Supply Voltage (for -5/-5I/-6/-6I)	2.3	2.5	2.7	V	2
V _{DD}	Power Supply Voltage (for -4)	2.4	2.5	2.6	V	2
V _{DDQ}	I/O Buffer Supply Voltage (for -5/-5I/-6/-6I)	2.3	2.5	2.7	V	2
V _{DDQ}	I/O Buffer Supply Voltage (for -4)	2.4	2.5	2.6	V	2
V _{REF}	Input reference Voltage	0.49 x V _{DDQ}	0.50 x V _{DDQ}	0.51 x V _{DDQ}	V	2, 3
V _{TT}	Termination Voltage (System)	V _{REF} - 0.04	V _{REF}	V _{REF} + 0.04	V	2, 8
V _{IH} (DC)	Input High Voltage (DC)	V _{REF} + 0.15	-	V _{DDQ} + 0.3	V	2
V _{IL} (DC)	Input Low Voltage (DC)	-0.3	-	V _{REF} - 0.15	V	2
V _{ICK} (DC)	Differential Clock DC Input Voltage	-0.3	-	V _{DDQ} + 0.3	V	15
V _{ID} (DC)	Input Differential Voltage. CLK and $\overline{\text{CLK}}$ inputs (DC)	0.36	-	V _{DDQ} + 0.6	V	13, 15
V _{IH} (AC)	Input High Voltage (AC)	V _{REF} + 0.31	-	-	V	2
V _{IL} (AC)	Input Low Voltage (AC)	-	-	V _{REF} - 0.31	V	2
V _{ID} (AC)	Input Differential Voltage. CLK and $\overline{\text{CLK}}$ inputs (AC)	0.7	-	V _{DDQ} + 0.6	V	13, 15
V _X (AC)	Differential AC input Cross Point Voltage	V _{DDQ} /2 - 0.2	-	V _{DDQ} /2 + 0.2	V	12, 15
V _{ISO} (AC)	Differential Clock AC Middle Point	V _{DDQ} /2 - 0.2	-	V _{DDQ} /2 + 0.2	V	14, 15

Notes: Undershoot Limit: V_{IL} (min) = -1.5V with a pulse width ≤ 5 nS

Overshoot Limit: V_{IH} (max) = V_{DDQ} + 1.5V with a pulse width ≤ 5 nS

V_{IH} (DC) and V_{IL} (DC) are levels to maintain the current logic state.

V_{IH} (AC) and V_{IL} (AC) are levels to change to the new logic state.



9.3 Capacitance

(V_{DD} = V_{DDQ} = 2.5V ±0.2V, f = 1 MHz, T_A = 25 °C, V_{OUT} (DC) = V_{DDQ}/2, V_{OUT} (Peak to Peak) = 0.2V)

SYMBOL	PARAMETER	MIN.	MAX.	DELTA (MAX.)	UNIT
C _{IN}	Input Capacitance (except for CLK pins)	2.0	4.0	0.5	pF
C _{CLK}	Input Capacitance (CLK pins)	3.0	5.5	0.25	pF
C _{I/O}	DQ, DQS, DM Capacitance	1.5	5.5	0.5	pF
C _{NC}	NC Pin Capacitance	-	1.5	-	pF

Notes: These parameters are periodically sampled and not 100% tested.

The NC pins have additional capacitance for adjustment of the adjacent pin capacitance.

9.4 Leakage and Output Buffer Characteristics

SYMBOL	PARAMETER	MIN.	MAX.	UNIT	NOTES
I _I (L)	Input Leakage Current (0V ≤ V _{IN} ≤ V _{DDQ} , All other pins not under test = 0V)	-2	2	μA	
I _O (L)	Output Leakage Current (Output disabled, 0V ≤ V _{OUT} ≤ V _{DDQ})	-5	5	μA	
V _{OH}	Output High Voltage (under AC test load condition)	V _{TT} +0.76	-	V	
V _{OL}	Output Low Voltage (under AC test load condition)	-	V _{TT} -0.76	V	
I _{OH} (DC)	Output Minimum Source DC Current	-15.2	-	mA	4, 6
I _{OL} (DC)	Output Minimum Sink DC Current	15.2	-	mA	4, 6
I _{OH} (DC)	Output Minimum Source DC Current	-10.4	-	mA	5
I _{OL} (DC)	Output Minimum Sink DC Current	10.4	-	mA	5
I _{OH} (DC)	Output Minimum Source DC Current	-7.2	-	mA	5
I _{OL} (DC)	Output Minimum Sink DC Current	7.2	-	mA	5



9.5 DC Characteristics

SYM.	PARAMETER	MAX.			UNIT	NOTES
		-4	-5/-5I	-6/-6I		
I _{DD0}	Operating current: One Bank Active-Precharge; $t_{RC} = t_{RC} \text{ min}$; $t_{CK} = t_{CK} \text{ min}$; DQ, DM and DQS inputs changing twice per clock cycle; Address and control inputs changing once per clock cycle	160	150	140	mA	7
I _{DD1}	Operating current: One Bank Active-Read-Precharge; Burst = 2; $t_{RC} = t_{RC} \text{ min}$; CL = 3; $t_{CK} = t_{CK} \text{ min}$; $I_{OUT} = 0 \text{ mA}$; Address and control inputs changing once per clock cycle.	180	170	160	mA	7, 9
I _{DD2P}	Precharge Power Down standby current: All Banks Idle; Power down mode; $CKE \leq V_{IL} \text{ max}$; $t_{CK} = t_{CK} \text{ min}$; $V_{in} = V_{REF}$ for DQ, DQS and DM	30	30	30	mA	
I _{DD2N}	Idle standby current: $\overline{CS} \geq V_{IH} \text{ min}$; All Banks Idle; $CKE \geq V_{IH} \text{ min}$; $t_{CK} = t_{CK} \text{ min}$; Address and other control inputs changing once per clock cycle; $V_{in} \geq V_{IH} \text{ min}$ or $V_{in} \leq V_{IL} \text{ max}$ for DQ, DQS and DM	45	45	45	mA	7
I _{DD3P}	Active Power Down standby current: One Bank Active; Power down mode; $CKE \leq V_{IL} \text{ max}$; $t_{CK} = t_{CK} \text{ min}$	30	30	30	mA	
I _{DD3N}	Active standby current: $\overline{CS} \geq V_{IH} \text{ min}$; $CKE \geq V_{IH} \text{ min}$; One Bank Active-Precharge; $t_{RC} = t_{RAS} \text{ max}$; $t_{CK} = t_{CK} \text{ min}$; DQ, DM and DQS inputs changing twice per clock cycle; Address and other control inputs changing once per clock cycle	60	60	60	mA	7
I _{DD4R}	Operating current: Burst = 2; Reads; Continuous burst; One Bank Active; Address and control inputs changing once per clock cycle; CL=3; $t_{CK} = t_{CK} \text{ min}$; $I_{OUT} = 0 \text{ mA}$	240	220	200	mA	7, 9
I _{DD4W}	Operating current: Burst = 2; Write; Continuous burst; One Bank Active; Address and control inputs changing once per clock cycle; CL = 3; $t_{CK} = t_{CK} \text{ min}$; DQ, DM and DQS inputs changing twice per clock cycle	270	250	230	mA	7
I _{DD5}	Auto Refresh current: $t_{RC} = t_{RFC} \text{ min}$	210	200	190	mA	7
I _{DD6}	Self Refresh current: $CKE \leq 0.2V$	3	3	3	mA	
I _{DD7}	Random Read current: 4 Banks Active Read with activate every 20nS, Auto-Precharge Read every 20 nS; Burst = 4; $t_{RCD} = 3$; $I_{OUT} = 0 \text{ mA}$; DQ, DM and DQS inputs changing twice per clock cycle; Address changing once per clock cycle	340	320	300	mA	



9.6 AC Characteristics and Operating Condition

SYM.	PARAMETER	-4		-5/-5I		-6/-6I		UNIT	NOTES	
		MIN.	MAX.	MIN.	MAX.	MIN.	MAX.			
trc	Active to Ref/Active Command Period	48		50		54		nS		
trfc	Ref to Ref/Active Command Period	60		70		70				
trAs	Active to Precharge Command Period	40	70000	40	100000	42	100000			
trCDRD	$\overline{\text{RAS}}$ to $\overline{\text{CAS}}$ delay for Read	5		4		3		tck		
trCDWR	$\overline{\text{RAS}}$ to $\overline{\text{CAS}}$ delay for Write	3		2		2				
trAP	Active to Read with Auto-precharge Enable	16		15		18		nS		
tCCD	Read/Write(a) to Read/Write(b) Command Period	1		1		1		tck		
trP	Precharge to Active Command Period	16		15		18		nS		
tRRD	Active(a) to Active(b) Command Period	12		10		12				
tWR	Write Recovery Time	3		3		2		tck		
tdAL	Auto-precharge Write Recovery + Precharge Time	-		-		-			18	
tck	CLK Cycle Time	CL = 2	-	-	7.5	12	7.5	12	nS	
		CL = 2.5	-	-	6	12	6	12		
		CL = 3	4	12	5	12	6	12		
		CL = 4	4	12	-	-	-	-		
tAC	Data Access Time from CLK, $\overline{\text{CLK}}$	-0.6	0.6	-0.7	0.7	-0.7	0.7	nS	16	
tdQsck	DQS Output Access Time from CLK, $\overline{\text{CLK}}$	-0.6	0.6	-0.6	0.6	-0.6	0.6			
tdQsQ	Data Strobe Edge to Output Data Edge Skew	-	0.4	-	0.4		0.4			
tCH	CLK High Level Width	0.45	0.55	0.45	0.55	0.45	0.55	tck	11	
tCL	CLK Low Level Width	0.45	0.55	0.45	0.55	0.45	0.55			
tHP	CLK Half Period (minimum of actual tCH, tCL)	min (tCL,tCH)		min, (tCL,tCH)		min, (tCL,tCH)		nS		
tQH	DQ Output Data Hold Time from DQS	tHP -0.5		tHP -0.5		tHP -0.5				
trPRE	DQS Read Preamble Time	0.9	1.1	0.9	1.1	0.9	1.1	tck	11	
trPST	DQS Read Postamble Time	0.4	0.6	0.4	0.6	0.4	0.6			
tdS	DQ and DM Setup Tim	0.4		0.4		0.4		nS		
tdH	DQ and DM Hold Time	0.4		0.4		0.4				
tdIPW	DQ and DM Input Pulse Width (for each input)	1.75		1.75		1.75				
tdQSH	DQS Input High Pulse Width	0.4	0.6	0.4	0.6	0.4	0.6	tck	11	
tdQSL	DQS Input Low Pulse Width	0.4	0.6	0.4	0.6	0.4	0.6			
tdSS	DQS Falling Edge to CLK Setup Time	0.2		0.2		0.2				
tdSH	DQS Falling Edge Hold Time from CLK	0.2		0.2		0.2				
tWPRES	Clock to DQS Write Preamble Set-up Time	0		0		0		nS		



AC Characteristics and Operating Condition, continued

SYM.	PARAMETER	-4		-5/-5I		-6/-6I		UNIT	NOTES
		MIN.	MAX.	MIN.	MAX.	MIN.	MAX.		
tWPREH	Clock to DQS Write Preamble Hold Time	0.25		0.25		0.25		tck	11
tWPST	DQS Write Postamble Time	0.4	0.6	0.4	0.6	0.4	0.6		
tdQSS	Write Command to First DQS Latching Transition	0.72	1.25	0.72	1.25	0.75	1.25		
tIS	Input Setup Time	0.75		0.75		0.8		nS	
tIH	Input Hold Time	0.75		0.75		0.8			
tHZ	Data-out High-impedance Time from $\overline{\text{CLK}}$, $\overline{\text{CLK}}$		0.7		0.7		0.7		
tLZ	Data-out Low-impedance Time from $\overline{\text{CLK}}$, $\overline{\text{CLK}}$	-0.7	0.7	-0.7	0.7	-0.7	0.7		
tT(SS)	SSTL Input Transition	0.5	1.5	0.5	1.5	0.5	1.5		
tWTR	Internal Write to Read Command Delay	2		2		1		tck	
tXSNR	Exit Self Refresh to non-Read Command	72		75		75		nS	
tXSRD	Exit Self Refresh to Read Command	200		200		200		tck	
tREFI	Refresh Interval Time (4K/64mS)		15.6		15.6		15.6	μS	17
tMRD	Mode Register Set Cycle Time	8		10		12		nS	

9.7 AC Test Conditions

PARAMETER	SYMBOL	VALUE	UNIT
Input High Voltage (AC)	V _{IH}	V _{REF} + 0.31	V
Input Low Voltage (AC)	V _{IL}	V _{REF} - 0.31	V
Input Reference Voltage	V _{REF}	0.5 x V _{DDQ}	V
Termination Voltage	V _{TT}	0.5 x V _{DDQ}	V
Input Signal Peak to Peak Swing	V _{SWING}	1.0	V
Differential Clock Input Reference Voltage	V _R	V _x (AC)	V
Input Difference Voltage. CLK and $\overline{\text{CLK}}$ Inputs (AC)	V _{ID} (AC)	1.5	V
Input Signal Minimum Slew Rate	SLEW	1.0	V/nS
Output Timing Measurement Reference Voltage	V _{OTR}	0.5 x V _{DDQ}	V

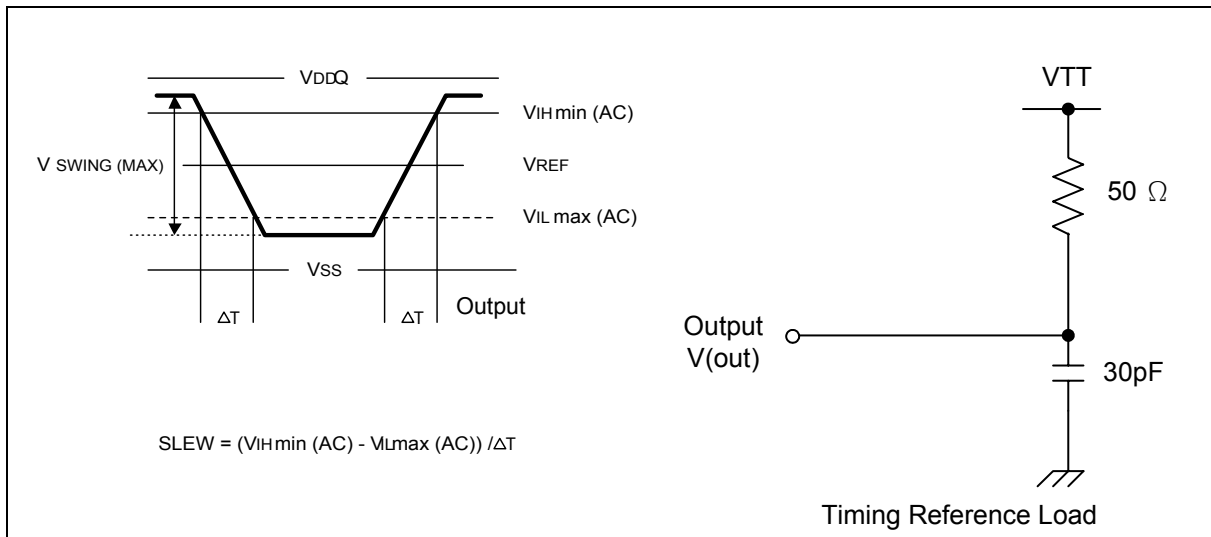
**Notes:**

- (1) Conditions outside the limits listed under "Absolute Maximum Ratings" may cause permanent damage to the device.
- (2) All voltages are referenced to V_{SS} , V_{SSQ} . ($2.5V \pm 0.1V$ for DDR500)
- (3) Peak to peak AC noise on V_{REF} may not exceed $\pm 2\%$ $V_{REF(DC)}$.
- (4) $V_{OH} = 1.95V$, $V_{OL} = 0.35V$
- (5) $V_{OH} = 1.9V$, $V_{OL} = 0.4V$
- (6) The values of $I_{OH(DC)}$ is based on $V_{DDQ} = 2.3V$ and $V_{TT} = 1.19V$.
The values of $I_{OL(DC)}$ is based on $V_{DDQ} = 2.3V$ and $V_{TT} = 1.11V$.
- (7) These parameters depend on the cycle rate and these values are measured at a cycle rate with the minimum values of t_{CK} and t_{RC} .
- (8) V_{TT} is not applied directly to the device. V_{TT} is a system supply for signal termination resistors is expected to be set equal to V_{REF} and must track variations in the DC level of V_{REF} .
- (9) These parameters depend on the output loading. Specified values are obtained with the output open.
- (10) Transition times are measured between $V_{IH\min}(\text{AC})$ and $V_{IL\max}(\text{AC})$. Transition (rise and fall) of input signals have a fixed slope.
- (11) IF the result of nominal calculation with regard to t_{CK} contains more than one decimal place, the result is rounded up to the nearest decimal place.
(i.e., $t_{DQSS} = 0.75 \times t_{CK}$, $t_{CK} = 7.5 \text{ nS}$, $0.75 \times 7.5 \text{ nS} = 5.625 \text{ nS}$ is rounded up to 5.6 nS .)
- (12) V_X is the differential clock cross point voltage where input timing measurement is referenced.
- (13) V_{ID} is magnitude of the difference between CLK input level and $\overline{\text{CLK}}$ input level.
- (14) V_{ISO} means $\{V_{ICK}(\text{CLK}) + V_{ICK}(\overline{\text{CLK}})\} / 2$.
- (15) Refer to the figure below.

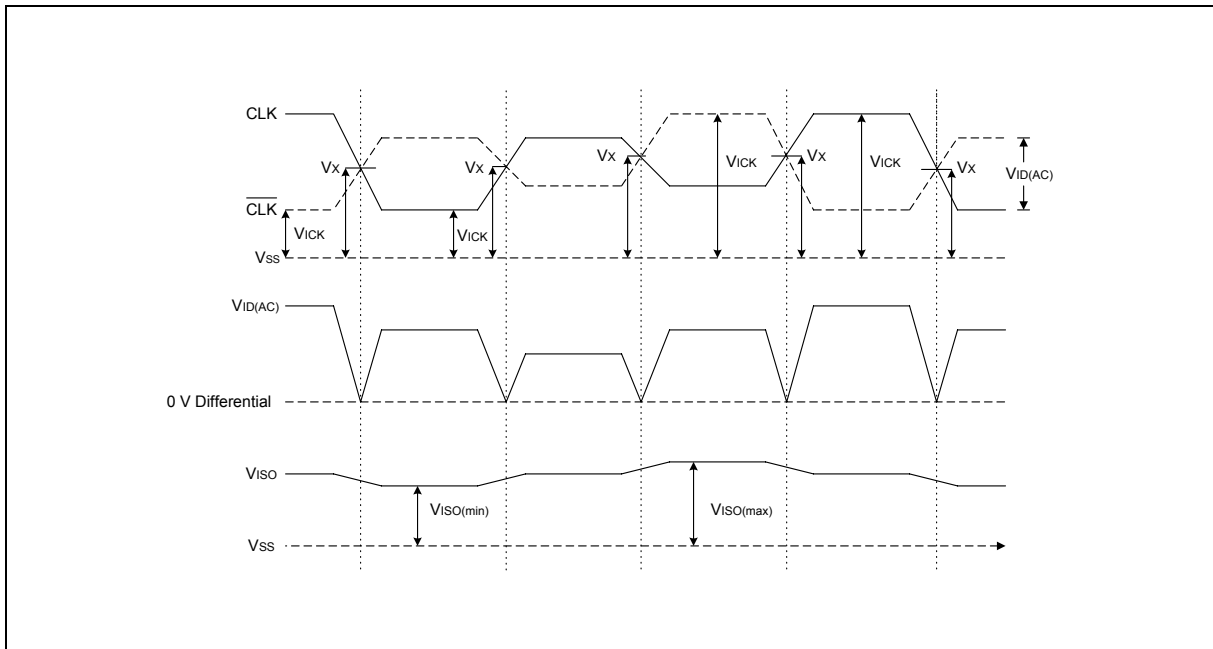

(16) t_{AC} and t_{DQSK} depend on the clock jitter. These timing are measured at stable clock.

(17) A maximum of eight AUTO REFRESH commands can be posted to any given DDR SDRAM device.

(18) $t_{DAL} = (t_{WR}/t_{CK}) + (t_{RP}/t_{CK})$



10. TIMING WAVEFORMS

10.1 Command Input Timing

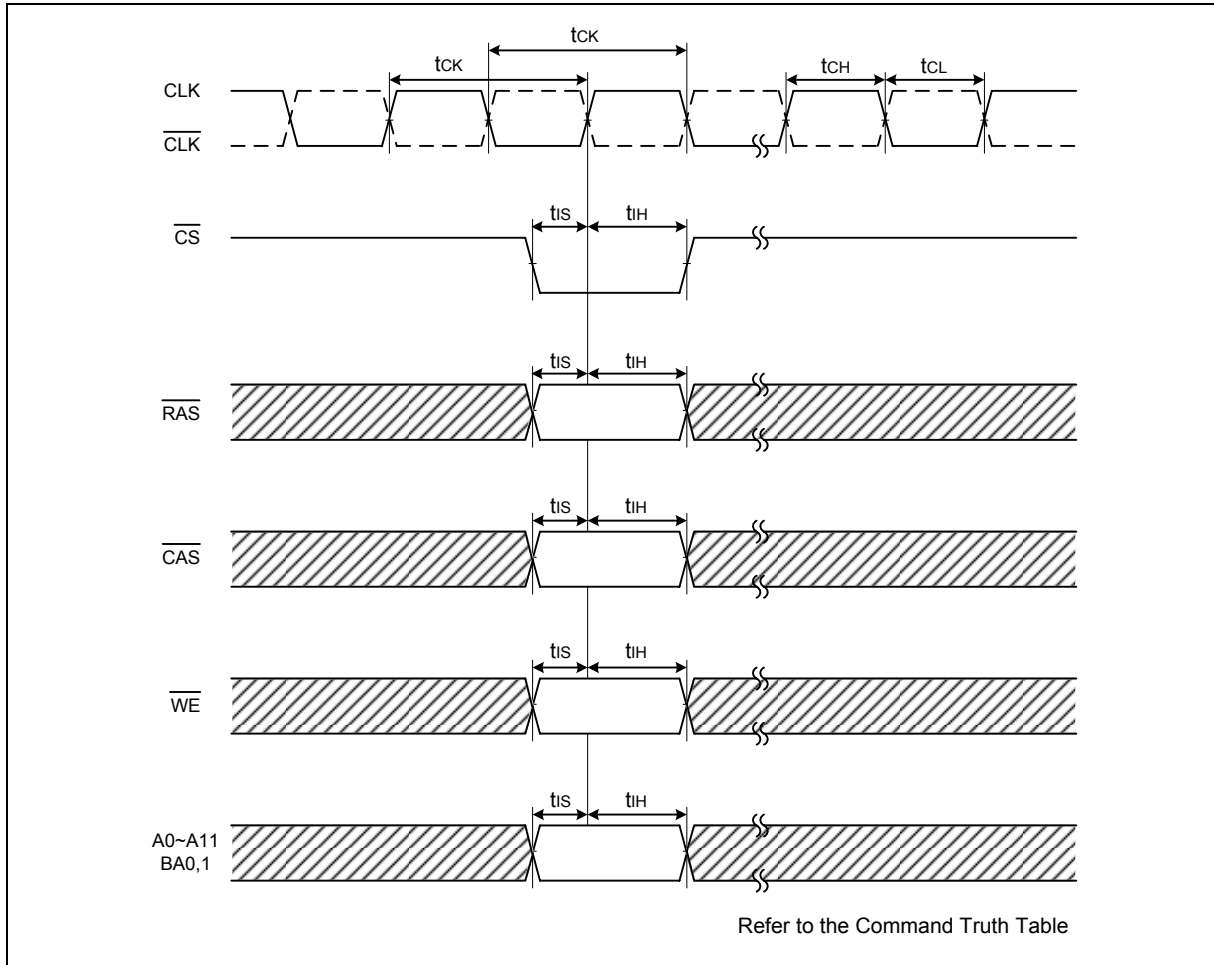

10.2 Timing of the CLK Signals

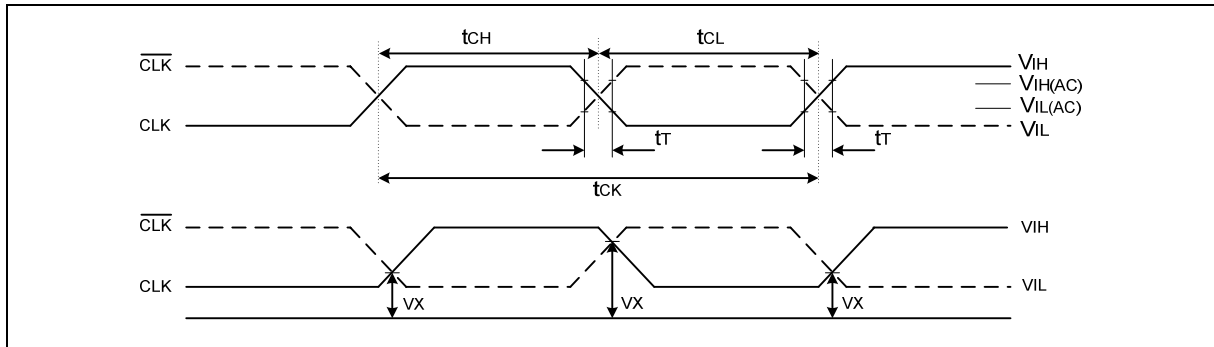



10.3 Read Timing (Burst Length = 4)

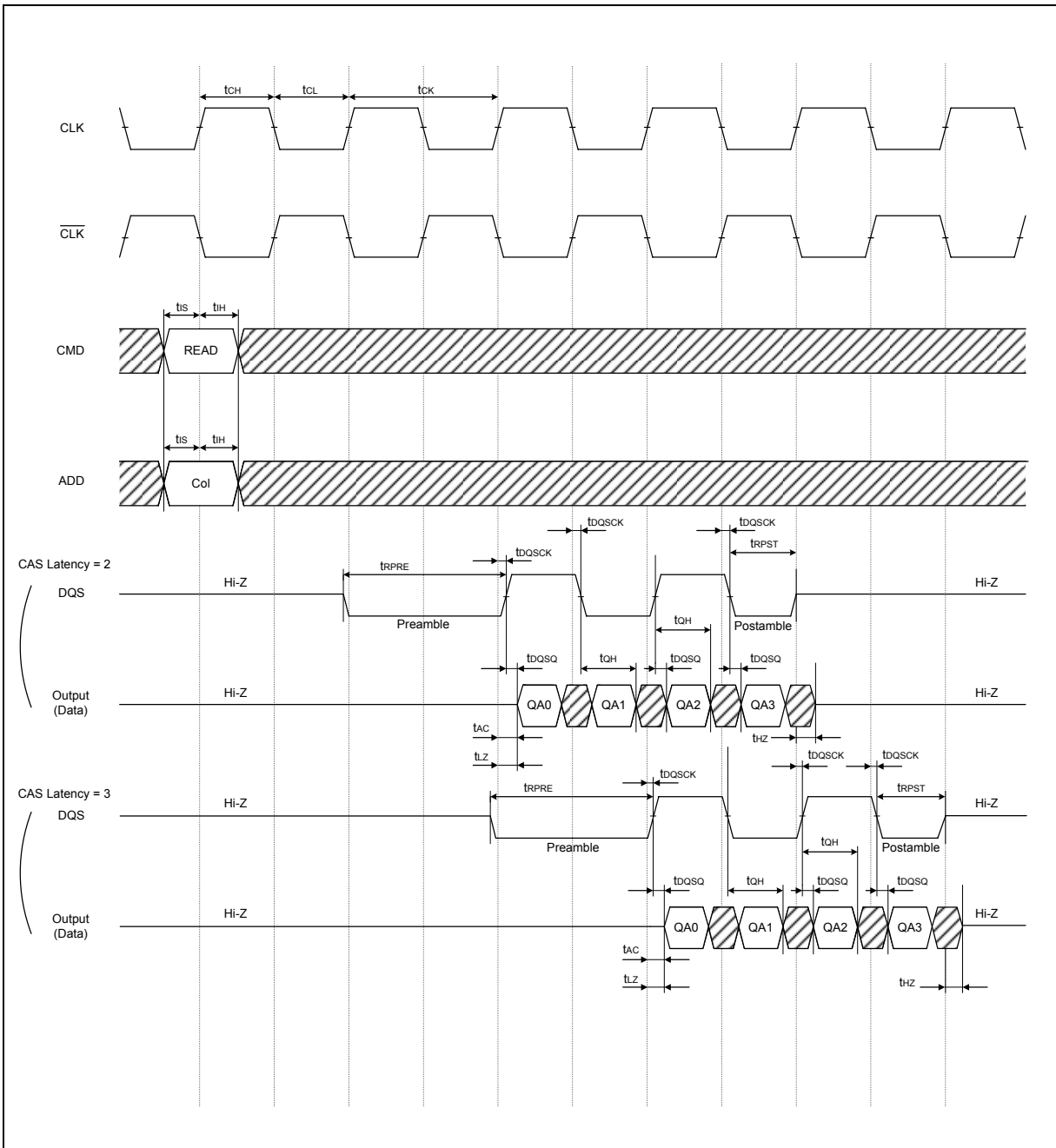

Notes: The correspondence of DQS0–DQS3 to DQ. (W9412G2IB)

DQS0	DQ0–7
DQS1	DQ8–15
DQS2	DQ16–23
DQS3	DQ24–31



10.4 Write Timing (Burst Length = 4)

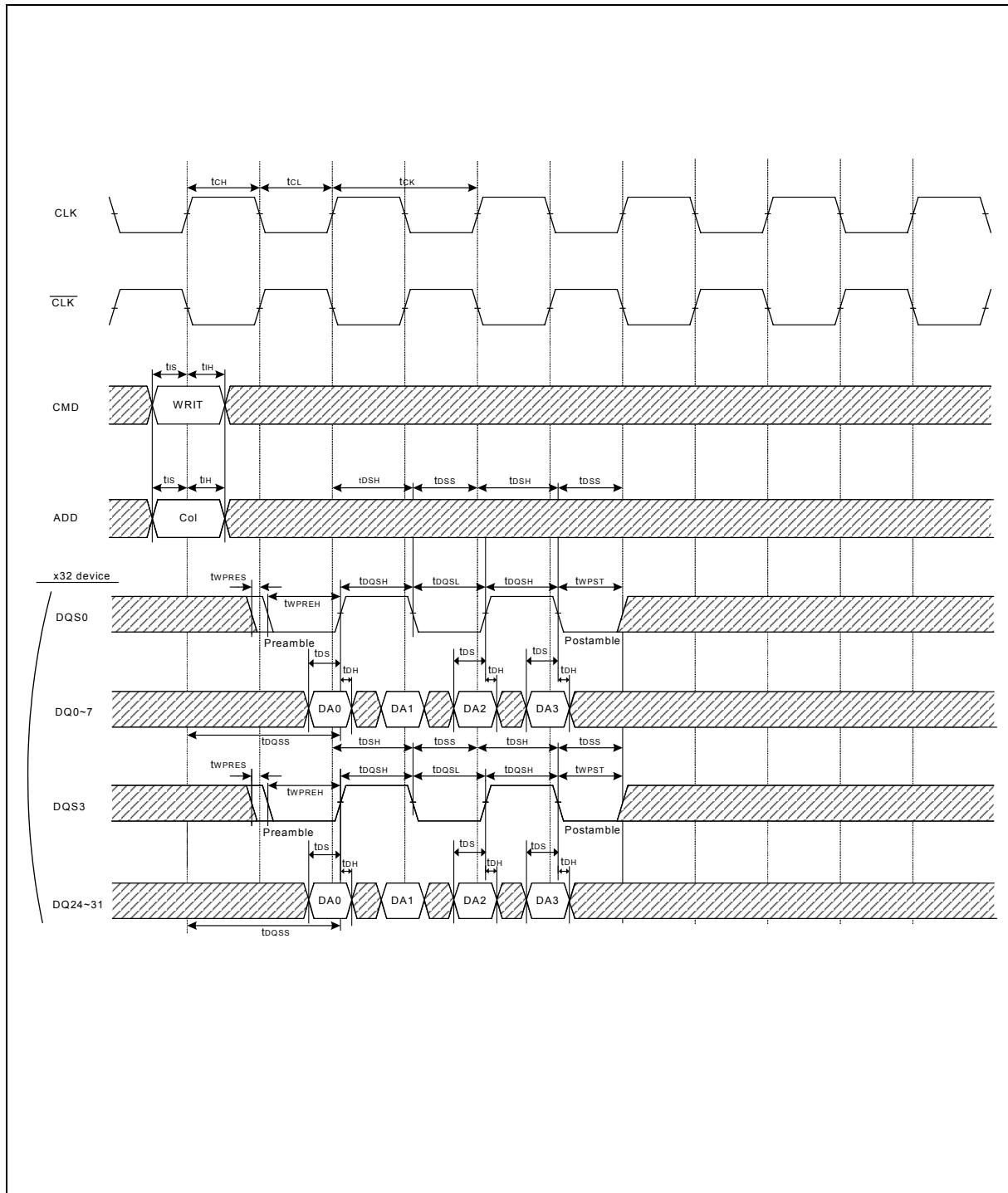

Note: x32 has four DQs. (DQS0 for lower byte and DQS3 for upper byte)



10.5 DM, DATA MASK (W9412G2IB)

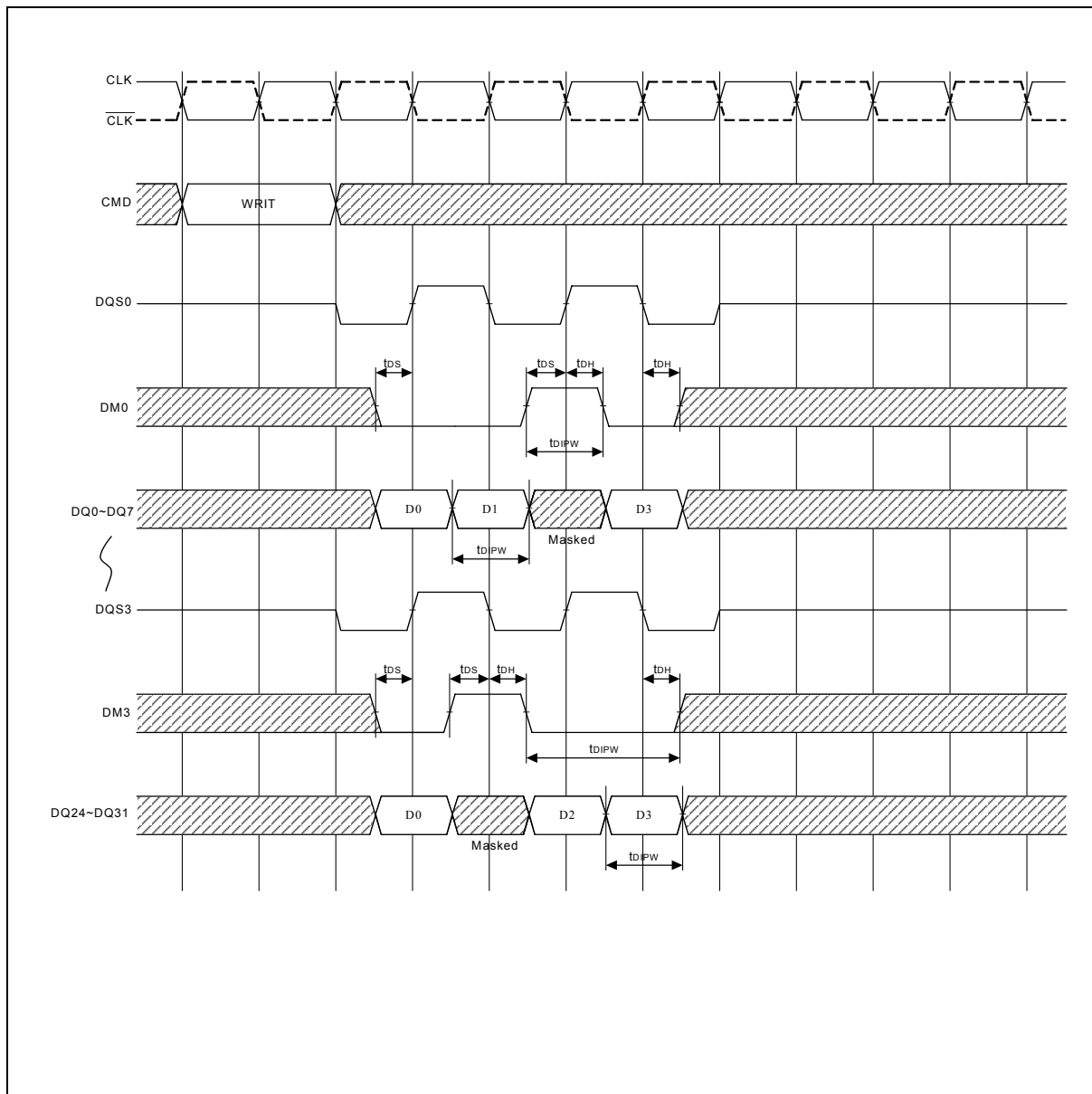



10.6 Mode Register Set (MRS) Timing

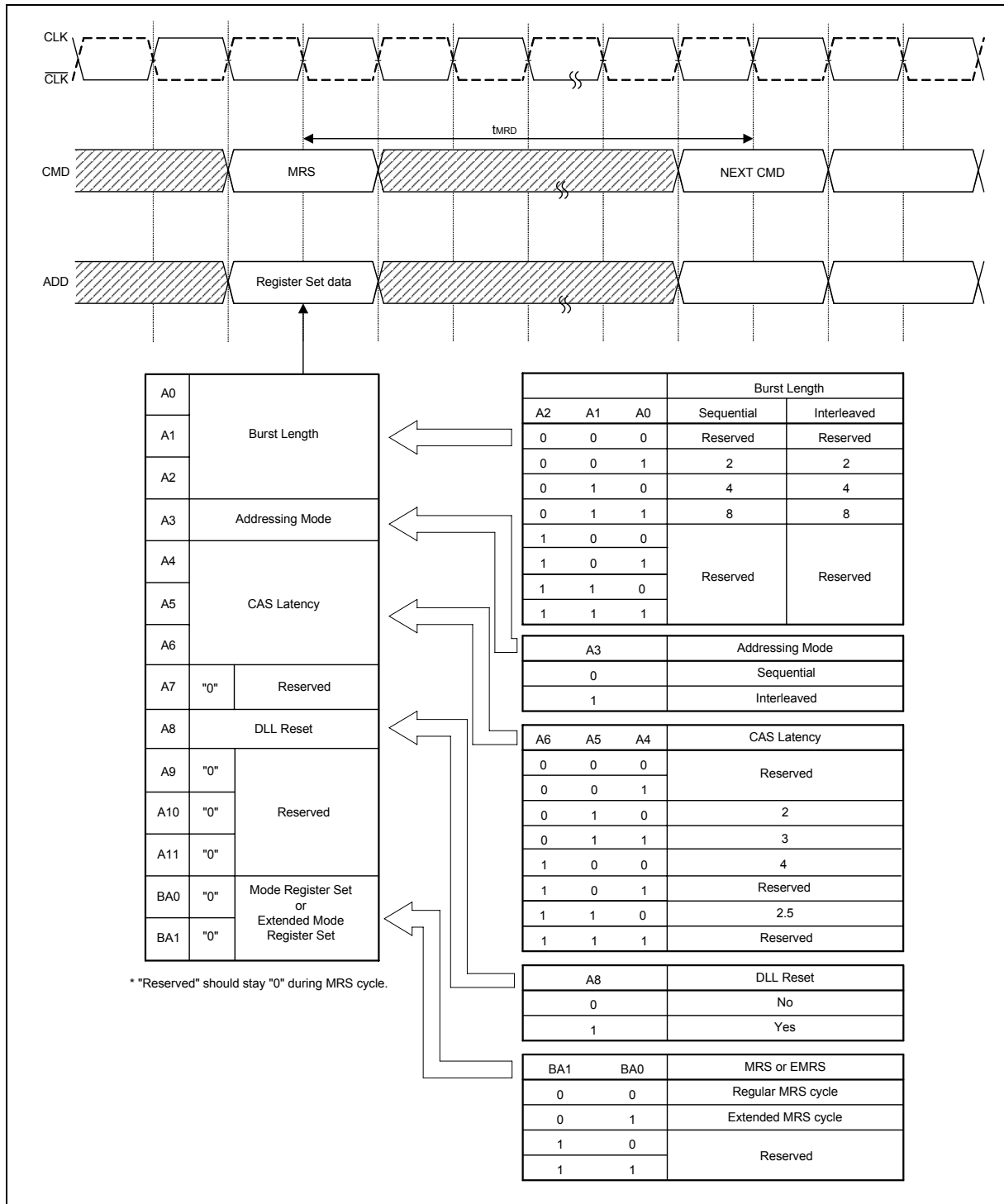



10.7 Extend Mode Register Set (EMRS) Timing

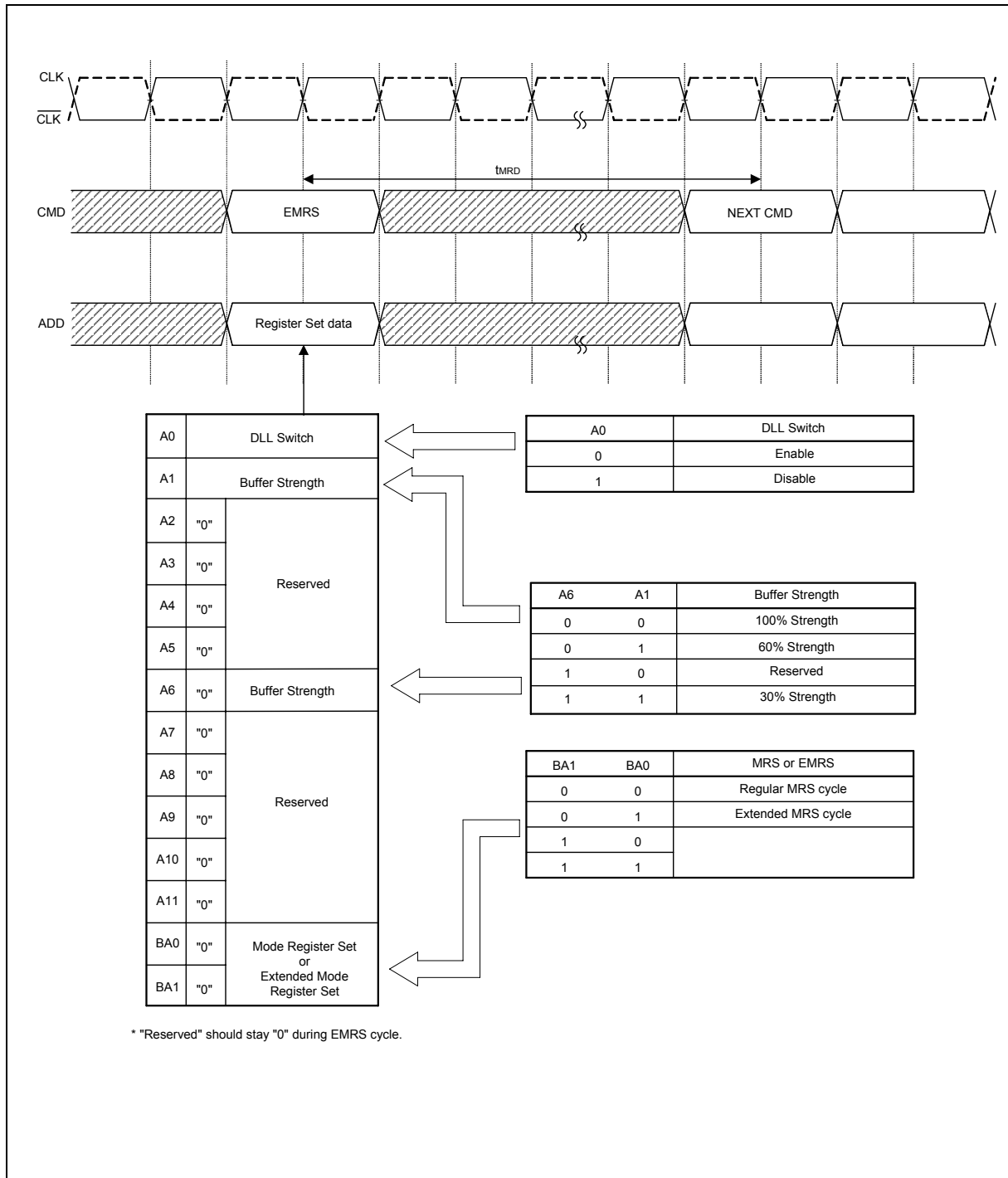



10.8 Auto-precharge Timing (Read Cycle, CL = 2)

1) $t_{RCD} (READA) \geq t_{RAS} (min) - (BL/2) \times t_{CK}$

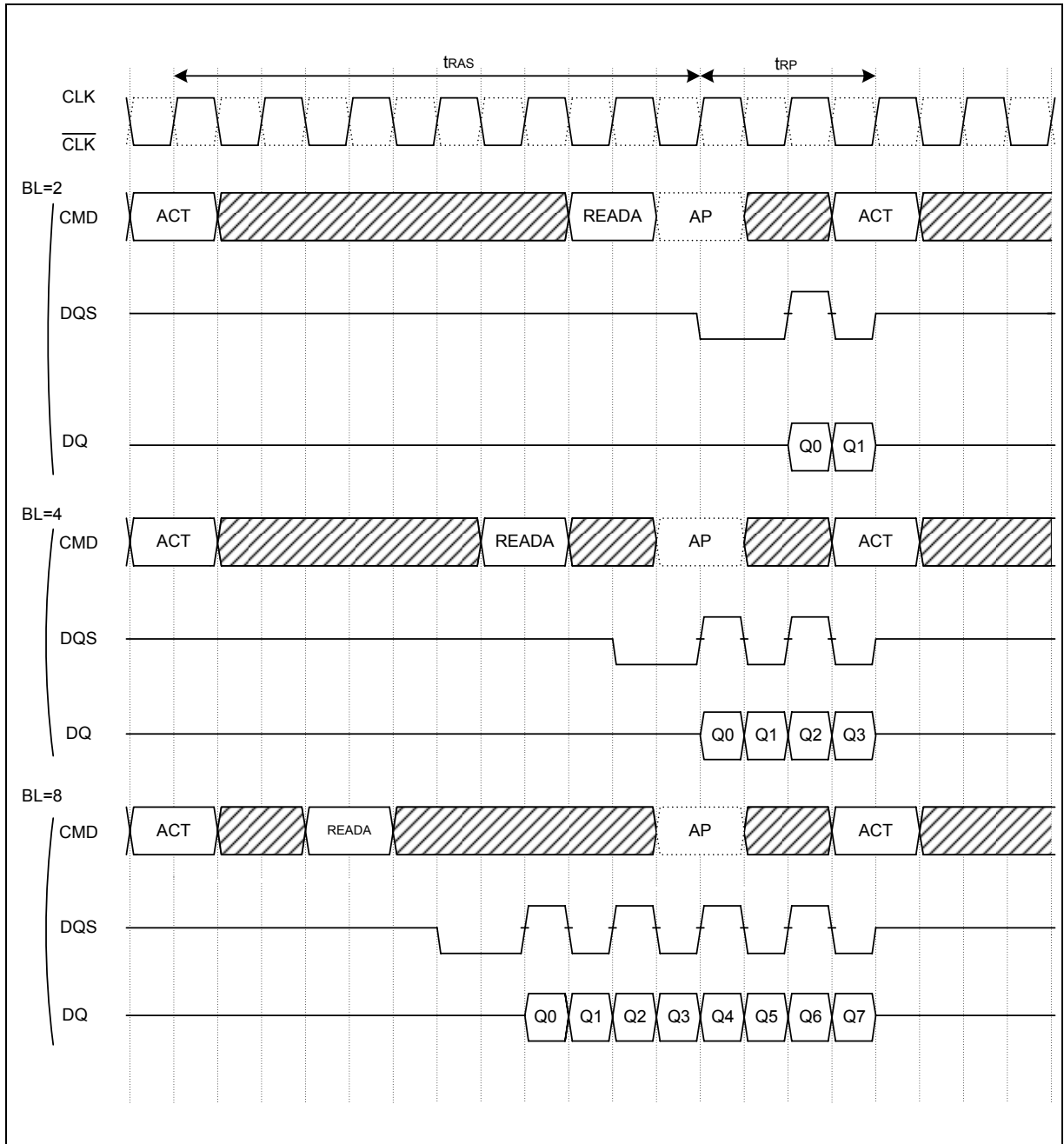

Notes: CL=2 shown; same command operation timing with CL=2.5 and CL=3
 In this case, the internal precharge operation begin after BL/2 cycle from READA command.

- AP Represents the start of internal precharging.
- The Read with Auto-precharge command cannot be interrupted by any other command.



10.9 Auto-precharge Timing (Read cycle, CL = 2), continued

2) $t_{RCD}/RAP(min) \leq t_{RCD} (READA) < t_{RAS} (min) - (BL/2) \times t_{CK}$

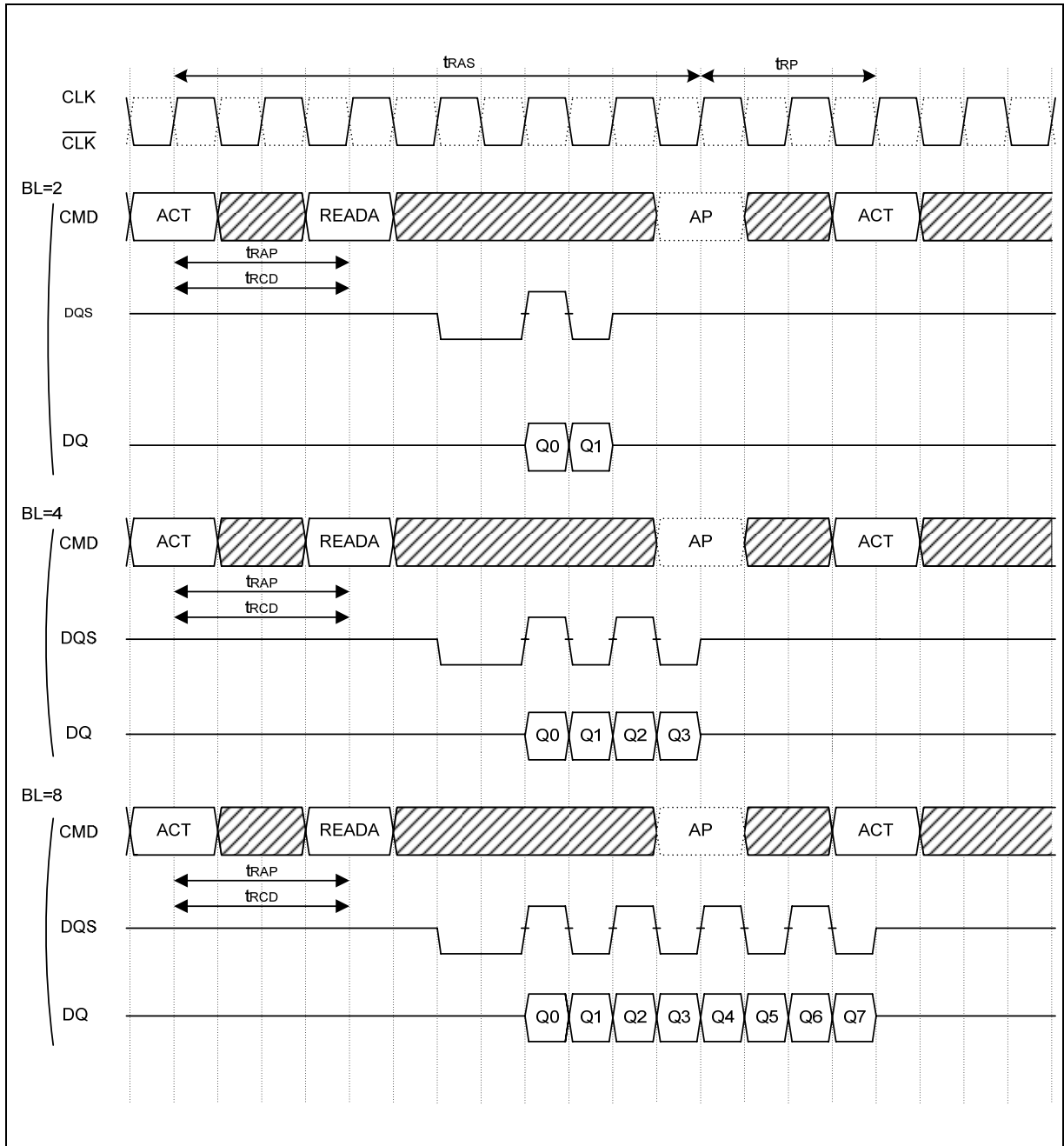

Notes: CL2 shown; same command operation timing with CL = 2.5, CL=3.

In this case, the internal precharge operation does not begin until after tRAS (min) has command.

 Represents the start of internal precharging.

The Read with Auto-precharge command cannot be interrupted by any other command.



10.10 Auto-precharge Timing (Write Cycle)

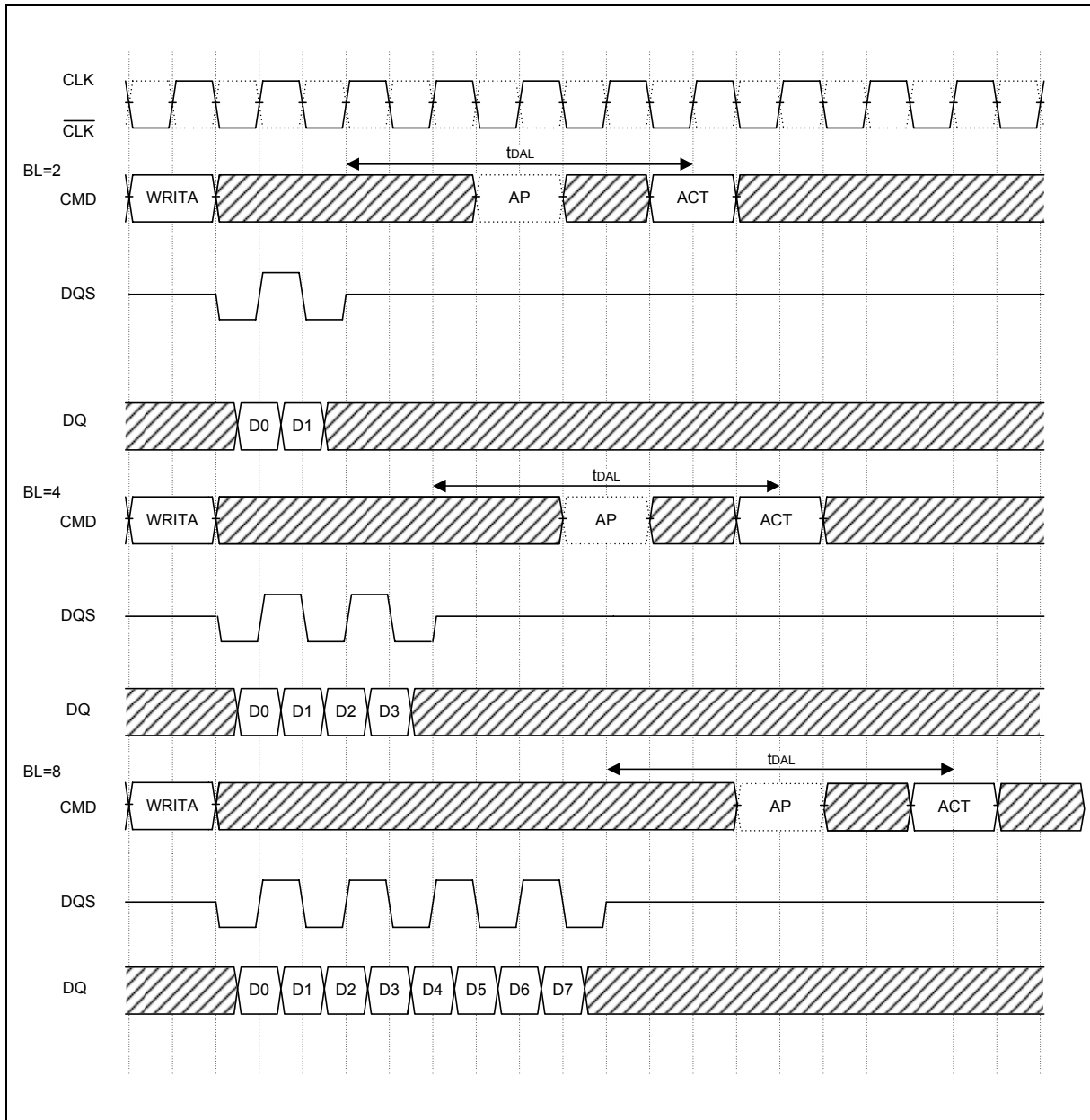

The Write with Auto-precharge command cannot be interrupted by any other command.

AP Represents the start of internal precharging.



10.11 Read Interrupted by Read (CL = 2, BL = 2, 4, 8)

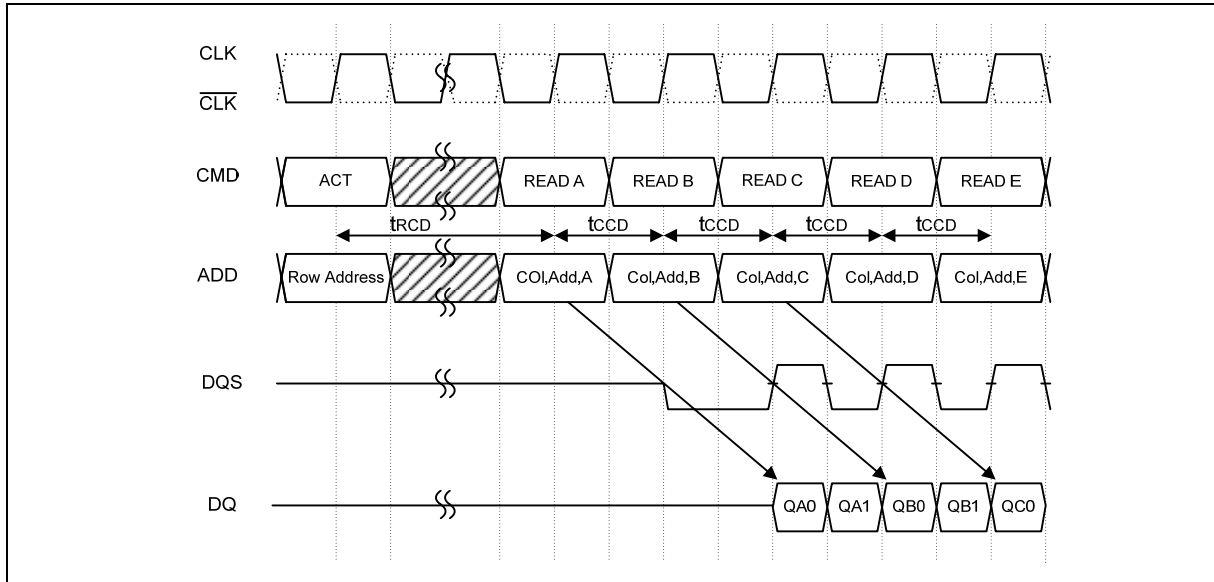

10.12 Burst Read Stop (BL = 8)

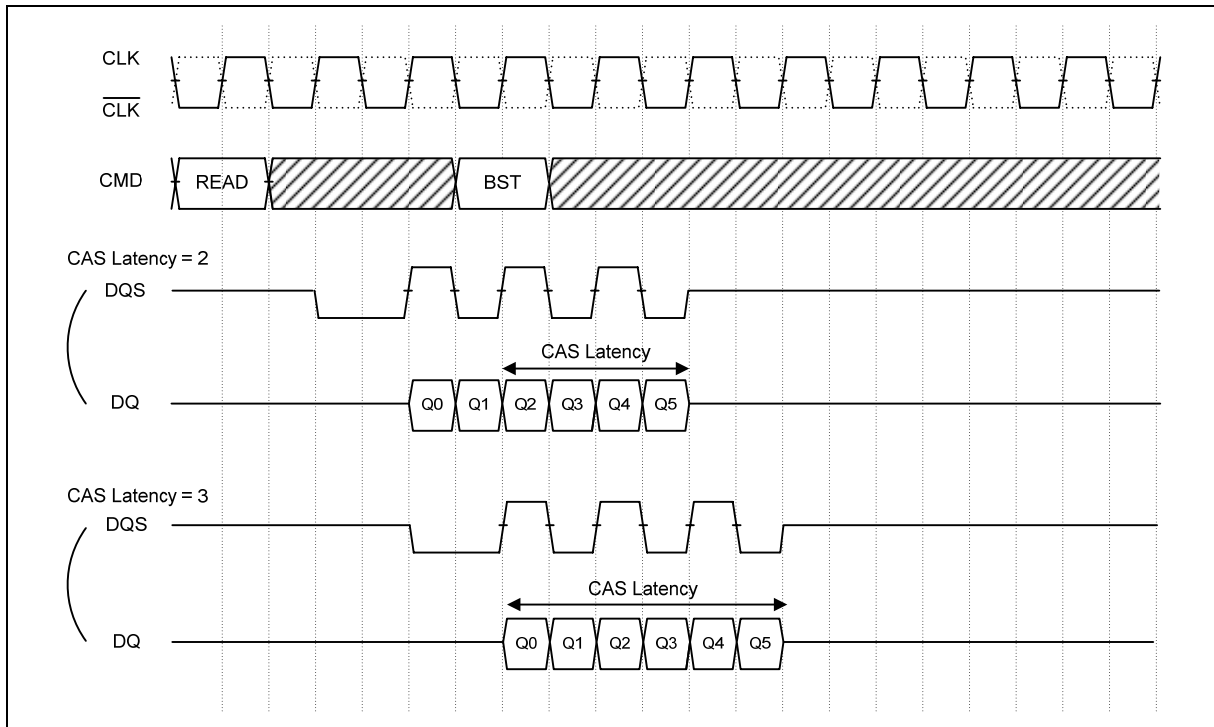



10.13 Read Interrupted by Write & BST (BL = 8)

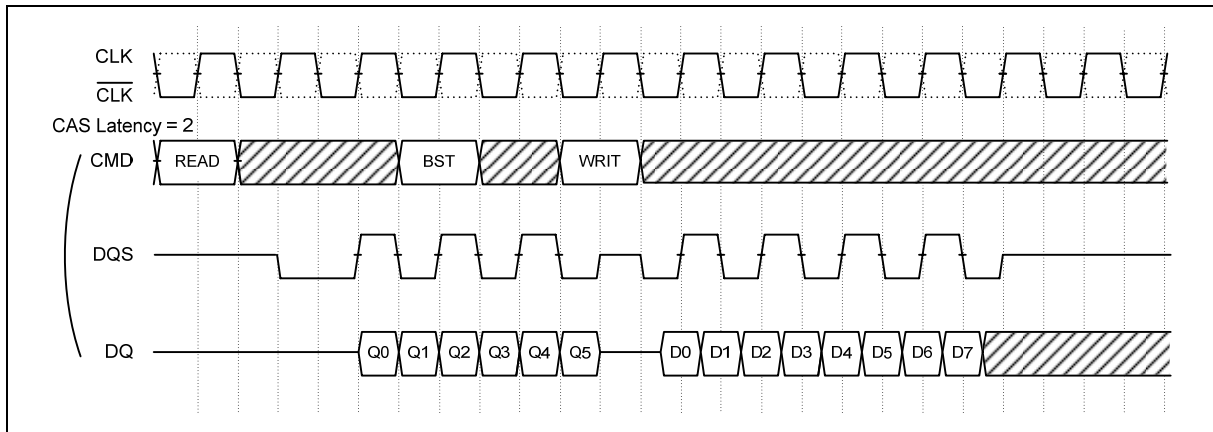

Burst Read cycle must be terminated by BST Command to avoid I/O conflict.

10.14 Read Interrupted by Precharge (BL = 8)

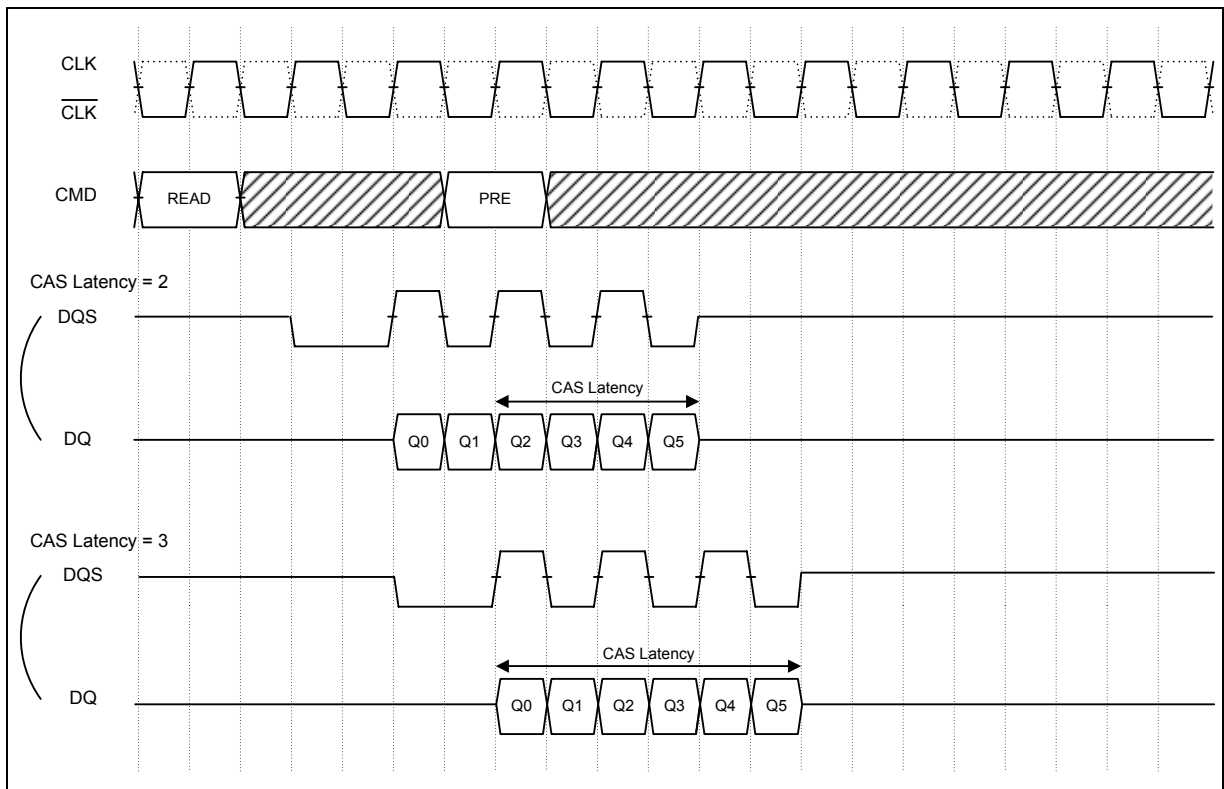



10.15 Write Interrupted by Write (BL = 2, 4, 8)

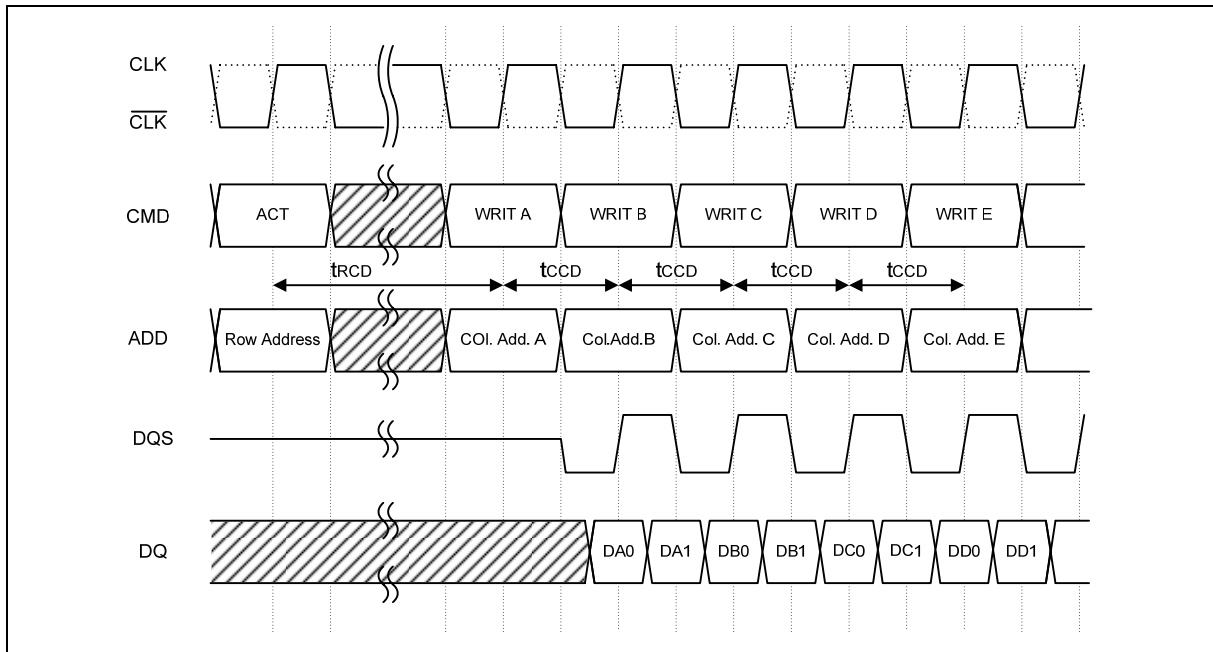

10.16 Write Interrupted by Read (CL = 2, BL = 8)

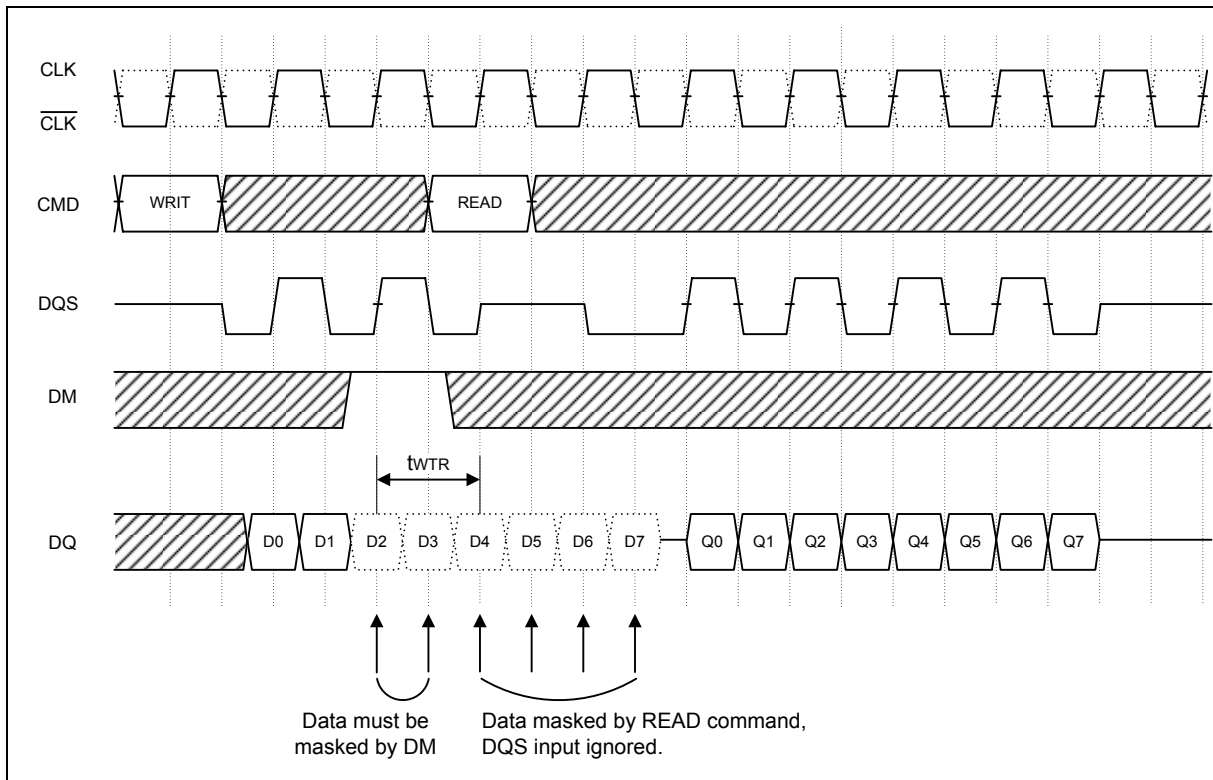



10.17 Write Interrupted by Read (CL = 3, BL = 4)

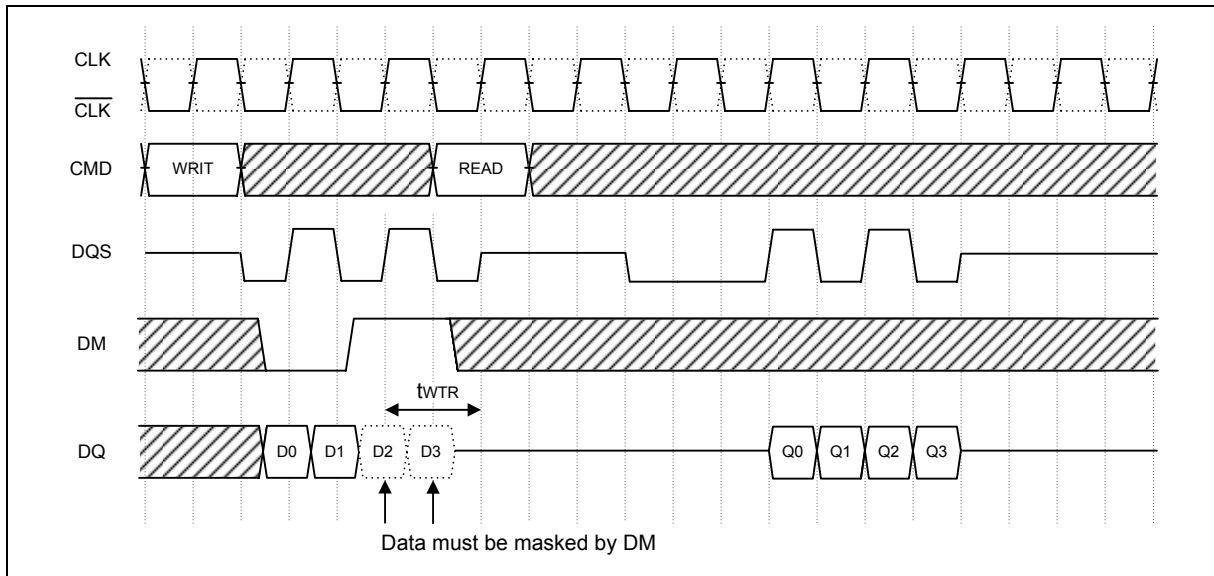

10.18 Write Interrupted by Precharge (BL = 8)

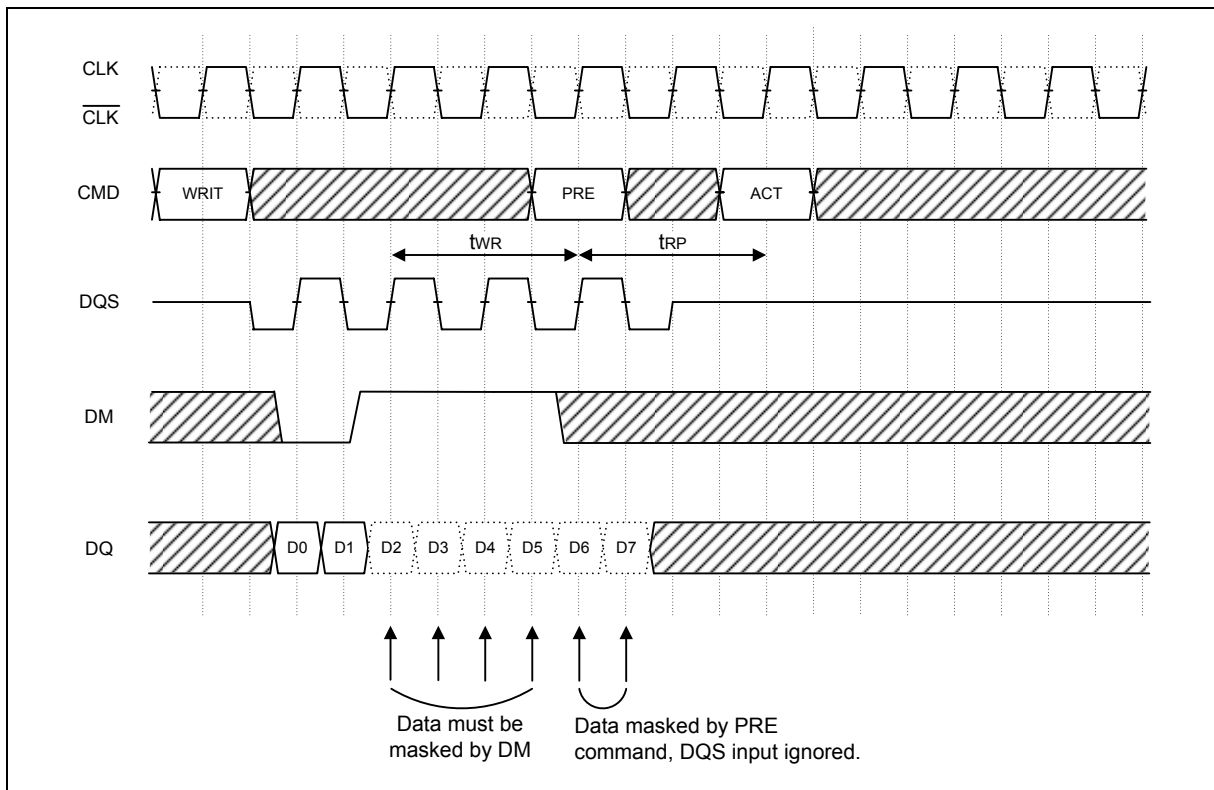



10.19 2 Bank Interleave Read Operation (CL = 2, BL = 2)

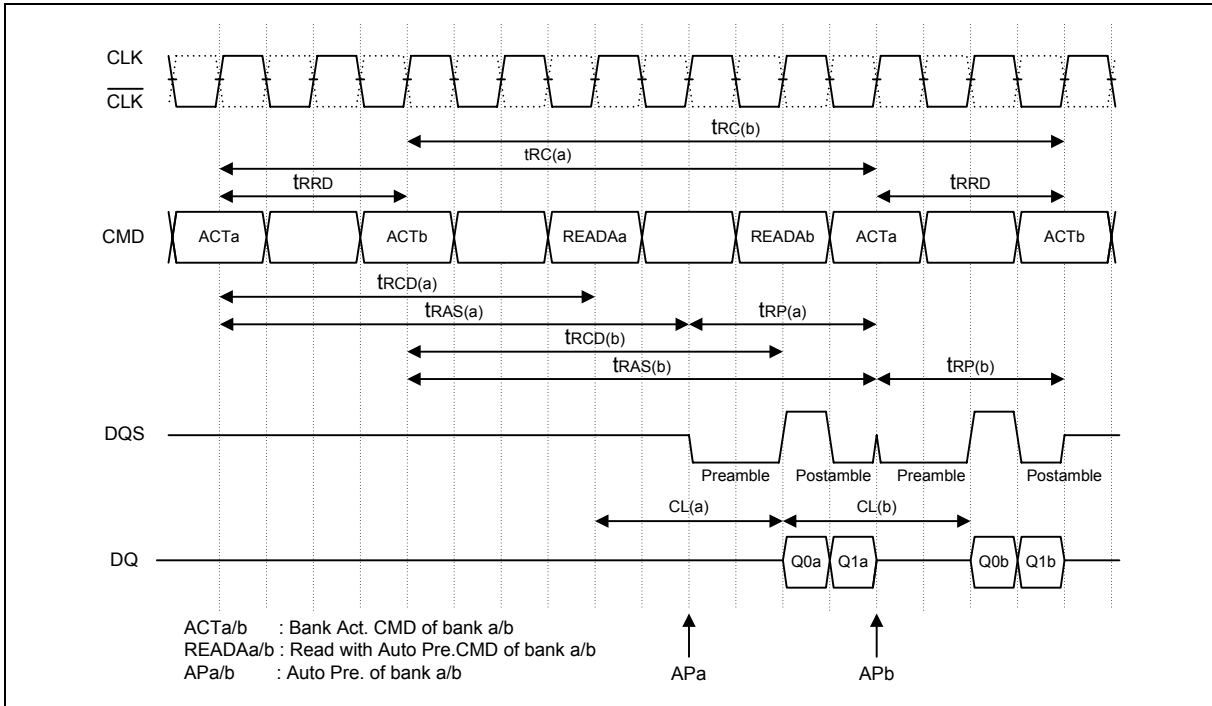

10.20 2 Bank Interleave Read Operation (CL = 2, BL = 4)

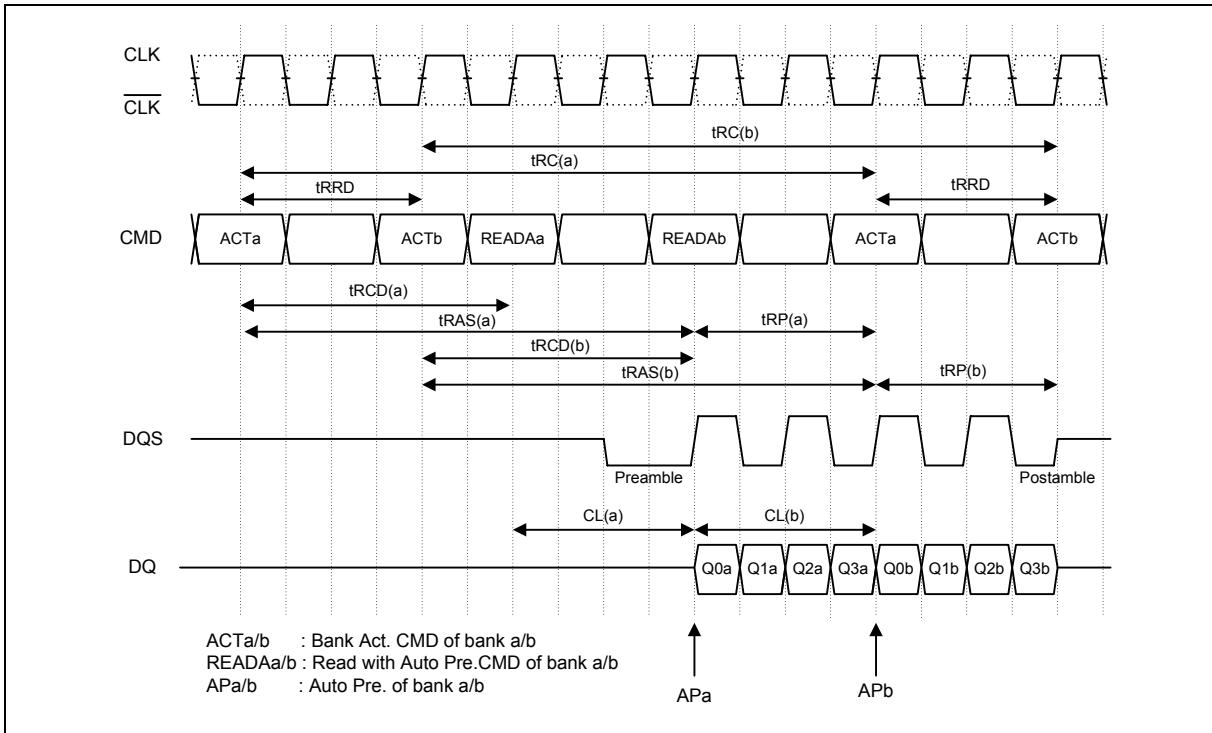



10.21 4 Bank Interleave Read Operation (CL = 2, BL = 2)

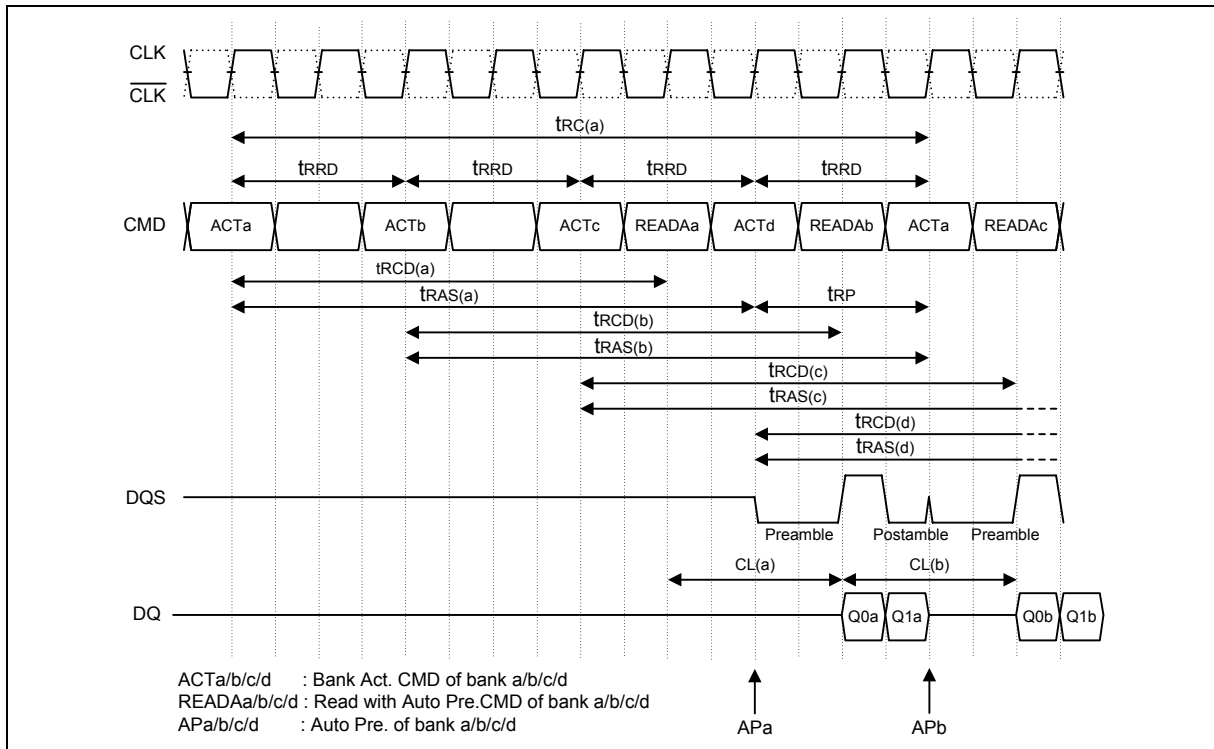

10.22 4 Bank Interleave Read Operation (CL = 2, BL = 4)

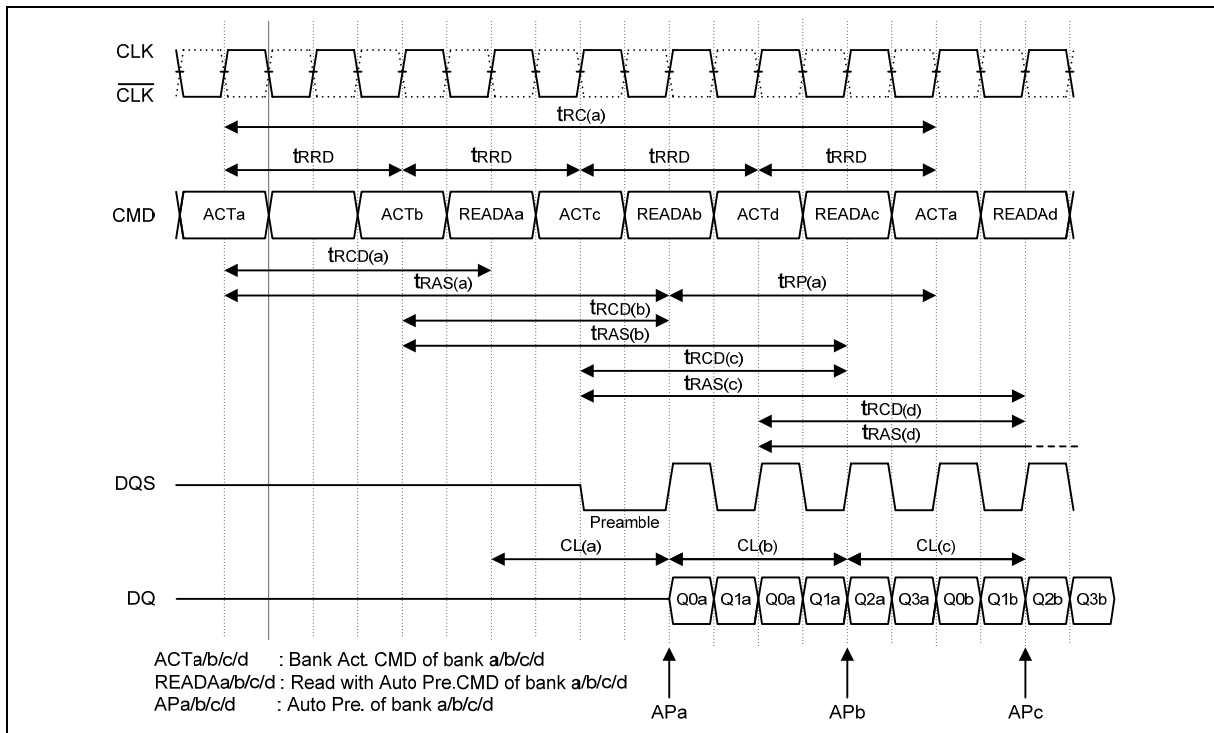



10.23 Auto Refresh Cycle

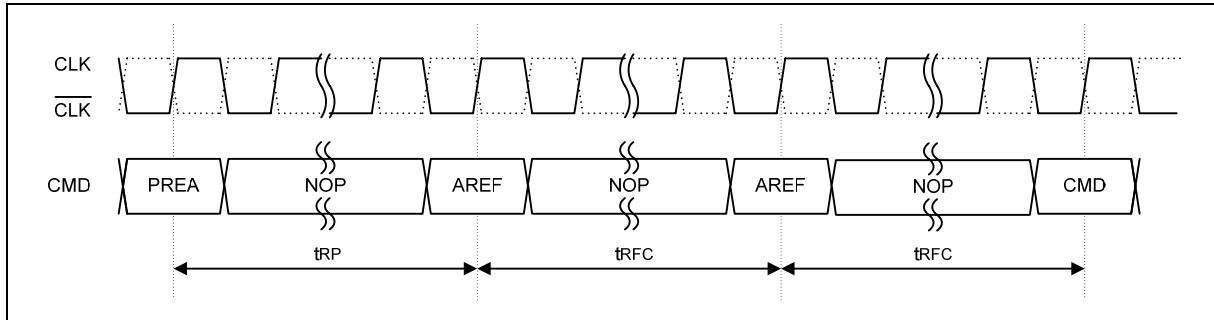

Note: CKE has to be kept "High" level for Auto-Refresh cycle.

10.24 Precharge/Activate Power Down Mode Entry and Exit Timing

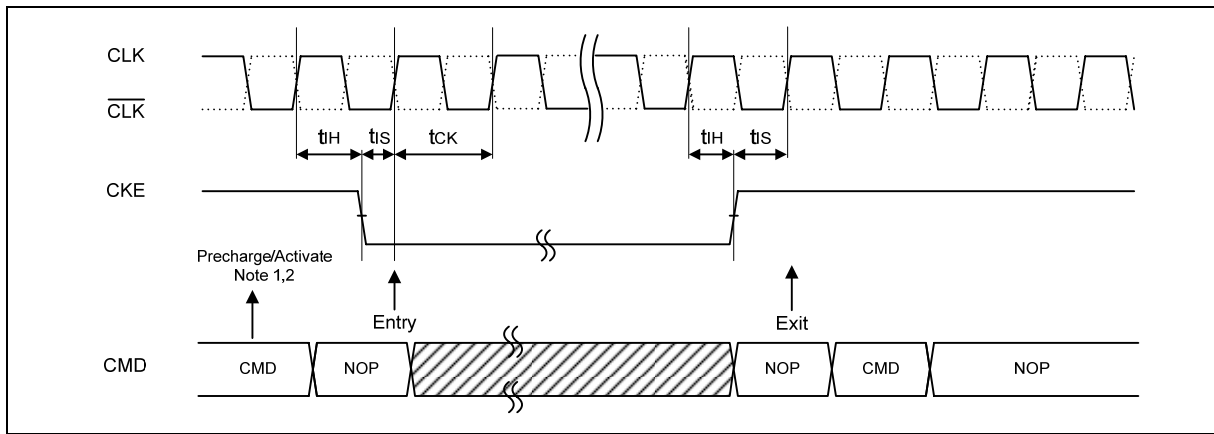

Note:

1. If power down occurs when all banks are idle, this mode is referred to as precharge power down.
2. If power down occurs when there is a row active in any bank, this mode is referred to as active power down.

10.25 Input Clock Frequency Change during Precharge Power Down Mode Timing

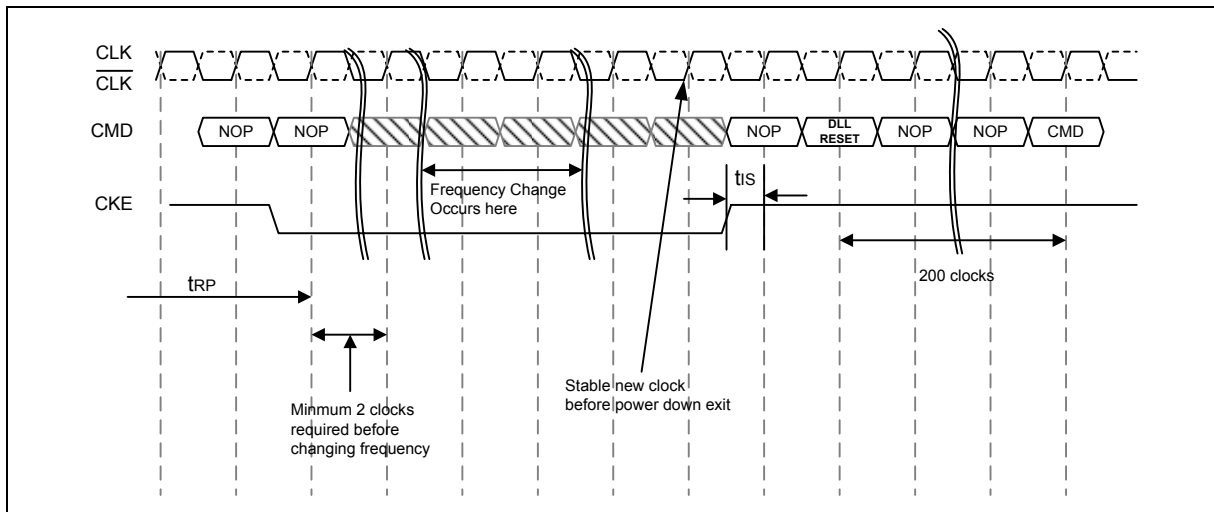



10.26 Self Refresh Entry and Exit Timing

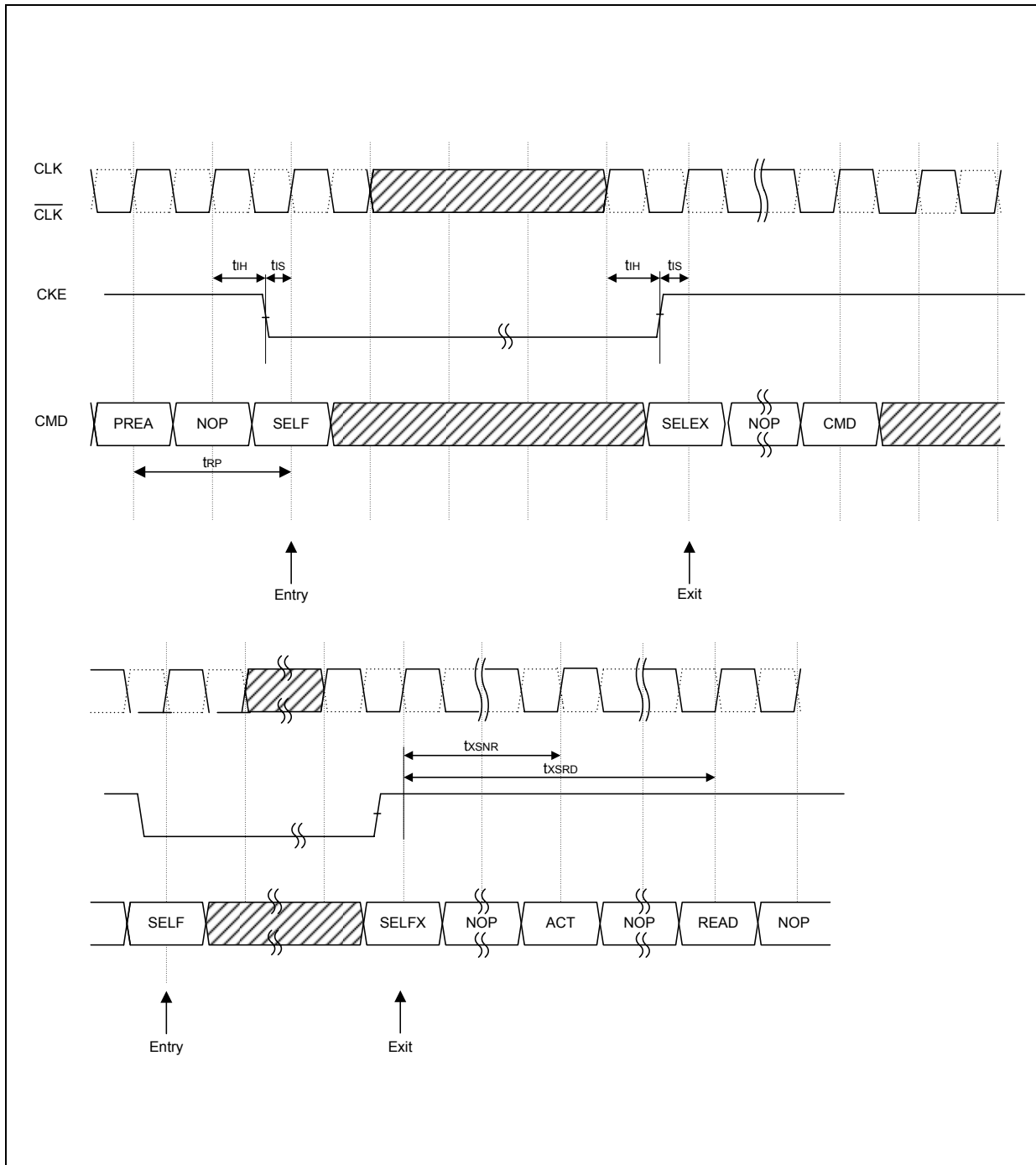

Note: If the clock frequency is changed during self refresh mode, a DLL reset is required upon exit.



11. PACKAGE SPECIFICATION

11.1 144L LFBGA (12X12X1.40 mm³, Ø=0.5mm)

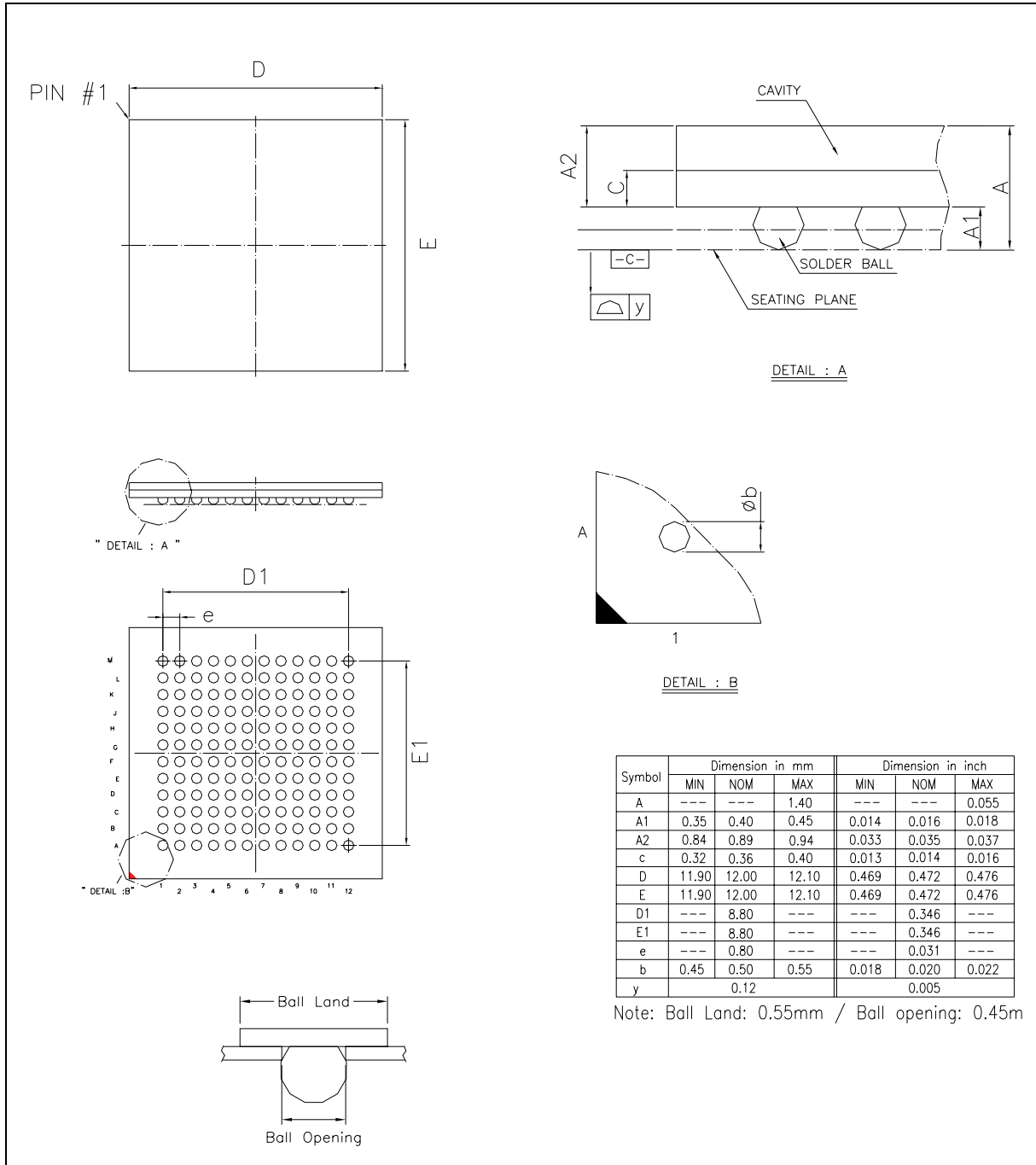

Symbol	Dimension in mm			Dimension in inch		
	MIN	NOM	MAX	MIN	NOM	MAX
A	---	---	1.40	---	---	0.055
A1	0.35	0.40	0.45	0.014	0.016	0.018
A2	0.84	0.89	0.94	0.033	0.035	0.037
c	0.32	0.36	0.40	0.013	0.014	0.016
D	11.90	12.00	12.10	0.469	0.472	0.476
E	11.90	12.00	12.10	0.469	0.472	0.476
D1	---	8.80	---	---	0.346	---
E1	---	8.80	---	---	0.346	---
e	---	0.80	---	---	0.031	---
b	0.45	0.50	0.55	0.018	0.020	0.022
y	---	0.12	---	---	0.005	---

Note: Ball Land: 0.55mm / Ball opening: 0.45mm



12. REVISION HISTORY

VERSION	DATE	PAGE	DESCRIPTION
A01	Aug. 19, 2008	All	Initial formally data sheet
A02	Sep. 18, 2008	28	Revise typo error of tRCDRD/tRCDWR AC parameters unit change the unit from nS to tCK
A03	Nov. 20, 2008	5, 27	Revise all speed grade DC parameter, IDDX values
A04	Apr. 20, 2009	4, 25, 30	Revise -4 speed grade power supply voltage range from 2.6V \pm 0.1V to 2.5V \pm 0.1V
A05	May 27, 2009	4, 5, 25, 27~29	Add -6I industrial grade parts
A06	Aug. 30, 2010	4, 5, 25, 27~29	Add -5I industrial grade parts

Important Notice

Winbond products are not designed, intended, authorized or warranted for use as components in systems or equipment intended for surgical implantation, atomic energy control instruments, airplane or spaceship instruments, transportation instruments, traffic signal instruments, combustion control instruments, or for other applications intended to support or sustain life. Further more, Winbond products are not intended for applications wherein failure of Winbond products could result or lead to a situation wherein personal injury, death or severe property or environmental damage could occur.

Winbond customers using or selling these products for use in such applications do so at their own risk and agree to fully indemnify Winbond for any damages resulting from such improper use or sales.

Please note that all data and specifications are subject to change without notice.
All the trademarks of products and companies mentioned in this datasheet belong to their respective owners.